

THE SPAD XIII C.1

WORLD WAR ONE AIRCRAFT MODELS

I have always held a fascination with early military aircraft. After serving for 27 years in the Royal Air Force, I became a Military Aerospace Technical Author. Although, as most modelers, I got involved in the world of construction kits at an early age, I stopped for most of my service career and for some years afterwards.

I started modeling again a few years ago and now enjoy the challenge of building aircraft of World War One. Since posting photographs of my completed models online, several people have asked if I would create a 'build log' for future builds.

I don't consider myself a 'master' of this craft, but hope to be able to pass on what I have learned. As such, here is my build log, which covers my build, including many modifications, of the Hobby Craft 1:32 scale model of the SPAD XIII C.1.

Mike 'Sandbagger' Norris

sandbaggeruk@sky.com

Completed: July 2018

INTRODUCTION

AFTER MARKET

THE MODEL

PREFACE

PART 1 - THE MODEL

Modifications or Corrections:

1. General preparation
2. Aileron animation
3. Elevator animation
4. Rudder animation
5. Engine cooling
6. Engine cowl/radiator detail
7. Cockpit surround panel
8. Engine bay (includes): Cockpit floor - Top decking panel - Forward fuselage - Engine - Decking panels - Clearances - Engine reduction gear - Radiator - Bulkheads - Engine bearers.
9. Fuselage internal
10. Access panels - mesh
11. Gun installations
12. Wheels
13. Ventral panel
14. Wing inboard 'H' support struts
15. Wing outboard rear support struts
16. Aileron controls: Operating rods - Wing slots - Bell crank assemblies
17. Rigging points
18. Rear fuselage - lifting straps
19. Gun sight assembly
20. Oil cooler drain valve
21. Undercarriage struts
22. Pipes - Upper wing to fuselage
23. Flying wire covers
24. Cockpit instruments (refer to Part 4 Cockpit)
25. Exhaust pipes and support brackets
26. Breather cap.

PART 2 - WOOD EFFECTS (General)

PART 3 - WEATHERING (General)

PART 4 - COCKPIT AND INTERNAL FUSELAGE

PART 5 - THE ENGINE

PART 6 - WHEELS

PART 7 - WEAPONS

PART 8 - PROPELLER

PART 9 - DECALS

PART 10 - RIGGING (General)

PART 11 - CONSTRUCTION

PART 12 – FIGURES AND ACCESSORIES

PART 13 - DISPLAY BASE

COMPLETED MODEL PHOTOGRAPHS

INTRODUCTION

Before I start with the build log, I'd like to show how I've set up my work area. I prefer to keep the work area as clear as I can (I've lost too many small items in the past). I think it's important to have the tools etc you need ready to hand and other, non-essential stuff tucked out of the way until needed. I'm lucky in that I have my 'man cave', which is sorted into a modelling area, airbrush spray booth in addition to my work station PC, games PC and games console.



AFTER MARKET

Pilot Figure

'Aviattic' - Lt. Frank Luke Jnr (ATTRES 022)
'Copper State' - RFC Mechanic (32-025)
'Wings Cockpit Figures' - Seated mechanic (RFC05C)

Decals

'Aviattic' Legend Series - Lt. Frank Luke Jnr 27th Aero Squadron (ATTL 01)

Detailing Items

'Airscale' Instrument Dial set (AS32 WW1) and the Instrument bezels (PE32 BEZ),
'Aviattic' - 1:32 Spad XIII 65 mm tyre wheels (ATTRES 023),
'Wingnut Wings' - 200 hp Hispano-Suiza Geared Engine sprue (132E0002).
'Gaspatch' -1:32 scale Vickers Machine Gun (Hyland Type B) (13-32046),
'Gaspatch' -1:32 scale Vickers 11 mm Balloon Machine Gun (13-32042),
'HGW' Photo-Etch Detail set (Gotha C.IV 132090 interior),
'HGW' textile seatbelts (132543), 'RB Productions' Radiator Mesh (RB-T027),
'Aber' photo-etched hand tools (35 A68),
'Kellerkind' tail trestle (Accessories set No.56/061).

Rigging accessories

'GasPatch' Elite Accessories Turnbuckles 1/48 scale (various types),
'Albion Alloy' Micro-tube and Rod (Brass or Nickel Silver - various diameters),
'Model Skills' pre-cut 'turnbuckles', 'RB Motion' Hex Nuts,
'Steelon' Mono-Filament 0.12 and 0.2 mm diameter.

Sundries

'Microscale's' MicroSet/Sol, Paints ('Tamiya' Acrylic, 'Humbrol' Acrylic,
'Mr Metal Colour', 'Alclad' and 'MRP' lacquers), 'Mr. Colour' Levelling Thinners,
Tamiya X20A Acrylic and X20 Enamel thinners,
'AK Extreme' Primer and Microfiller, 'AK Interactive' figure paints,
PVA Adhesive, 'Abteilung 502' oil paints, Cyanoacrylate (CA) glue (thin),
'VMS' Fleky 5K CA adhesive, Bostik 'Blu Tack' or UHU 'White Tack', 'Vallejo' Plastic Putty,
'Masilla Plastica (401) putty, Sanding and/or Polishing sticks from 'Flory Models',
'Vallejo' Still Water (26.230), 'PlusModel' lead wires, 'Milliput' two part putty,
'Albion Alloys' Connecto, Soft solder, 'Max Gold' liquid soldering flux.

Weathering mediums

'Flory Models' clay washes and pigments, 'AK Interactive' engine washes,
'Tamiya' Weathering Master sets

Display Base

'Inperspective' Acrylic base and cover (built to order), Etched plaque (information plate),
'Polak' grass mat (Wild Meadow, variation F-4706).

THE MODEL

Hobby Craft Spad XIII C.1 (International Edition) (HC1688)

The Hobby Craft model of the Spad XIII C.1 is, as far as I'm aware, probably the only 1:32 scale model of this aircraft produced, and for some time has proved extremely difficult to obtain. This kit itself is some years old, and its contents show this. By comparison to more modern model, such as Wingnut Wings, the kit parts are few. There are only three sprues containing parts, the two wings being separate, and a clear parts sprue. Given its age the kit parts are good and do not have much in the way of ejector pin marks or flash around the smaller items. The detail on the parts is good, but as always there is scope for the modeller to correct or modify the model for greater accuracy and detail.



The kit instructions comprise the front page, three assembly instruction pages and finally a page with a rigging diagram. There are advisory notes, such as having to trim the height of the outer wing struts, but primarily it's up to the modeller to follow the illustrations for assembly.

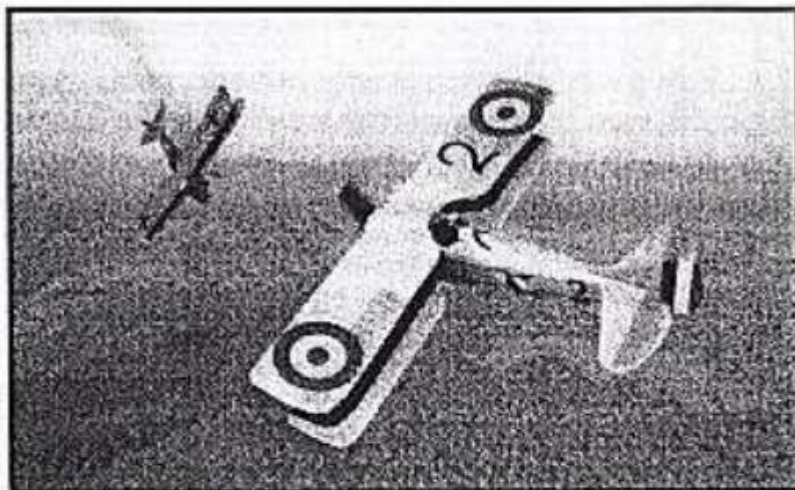

SPAD XIII

HC1688 • 1:32 • "SPAD International"

Kit features: detailed cockpit • landing gear • precise moldings • authentic markings.

Particularités du kit: • l'intérieur détaillé • train d'atterrissage très détaillé • moulage précis • les marques authentiques.

Caratteristica del modello: • carlinga dettagliata e carrello di atterraggio • dettagli incisi • decals autentici.

Der Bausatz enthält: • detailliertes Cockpit und Fahrwerk • fein eingravierte Details • authentische Abziehbilder.

Características del kit: • se detallan la cabina del piloto y el aterrizador • marcas auténticas.

COLOR	FLOQUIL/POLLY SCALE**	HUMBROL**	TESTORS MODELMASTER**
French Beige FS20318	505210/110084*	188*	2103
French Dark Green FS34088	Old Concrete/Foundation*	Hemp*	RAL 7027 Brown Gray
French Dark Brown FS20140	505360/303381	155*	2125
French Light Green Methuen 3C5	Soviet Khaki #2	Matt Olive Drab*	Earth Gray
French U/S Gray Methuen 103	505041/303139	n/a	2108
French U/S Yellow Methuen 4B4	Fr. Chestnut/Fr. Earth Brown	n/a	Fr. Earth brown
	414366/ Weyerhaeuser Green	n/a	2029*
	414317/110082	n/a*	Green*
	Concrete		2120
	505044	183	Topside Gray
	French Beige	Matt Cream	2104*
			Interior Buff*

*Approximate Match. **Some paints may not be available in your country. Please check with your local hobby shop for substitute colors.



© Hobbycraft™ Canada, 140 Applewood Crescent, Concord, Ontario L4K 4E2, Canada
All rights reserved. Made in China.

© Hobbycraft™ Canada, 140 Applewood Crescent, Concord, Ontario L4K 4E2, Canada
Tous droits réservés. Fabriqué en Chine.



Read This Before You Begin!

- study the assembly drawings
- each plastic part is identified by a number
- check the fit of each piece before assembling
- fit all kit kit must contact in joint parts
- model may be painted to match box illustrations

Lisez Ce Qui Suit Avant de Commencer Le Montage!

- étudier les schémas d'assemblage
- chaque pièce plastique porte un numéro d'identification
- vérifier que chaque pièce est bien conforme avant de la coller à sa place
- utiliser uniquement une colle spéciale pour polystyrène
- le model peut être peint conformément aux illustrations de la boîte

Vor Zusammenbau lesen sie bitte!

- studieren die Zusammenbauzeichnungen
- die Kunststoffteile sind gekennzeichnet durch ihre Nummern
- vor dem Kleben prüfen ob die Teile zusammenpassen können
- benutzen nicht andere Klebstoffe!
- die Bemalung der Modelle kann auf dem Deckbild zeigen

1

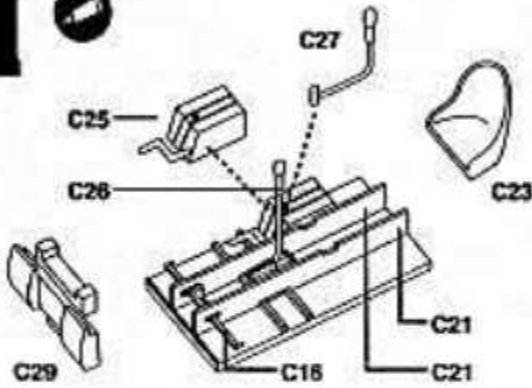

2

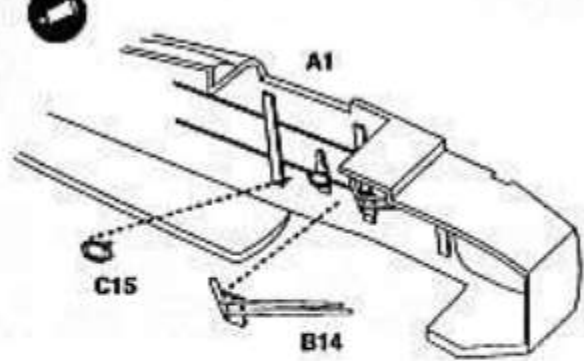

3

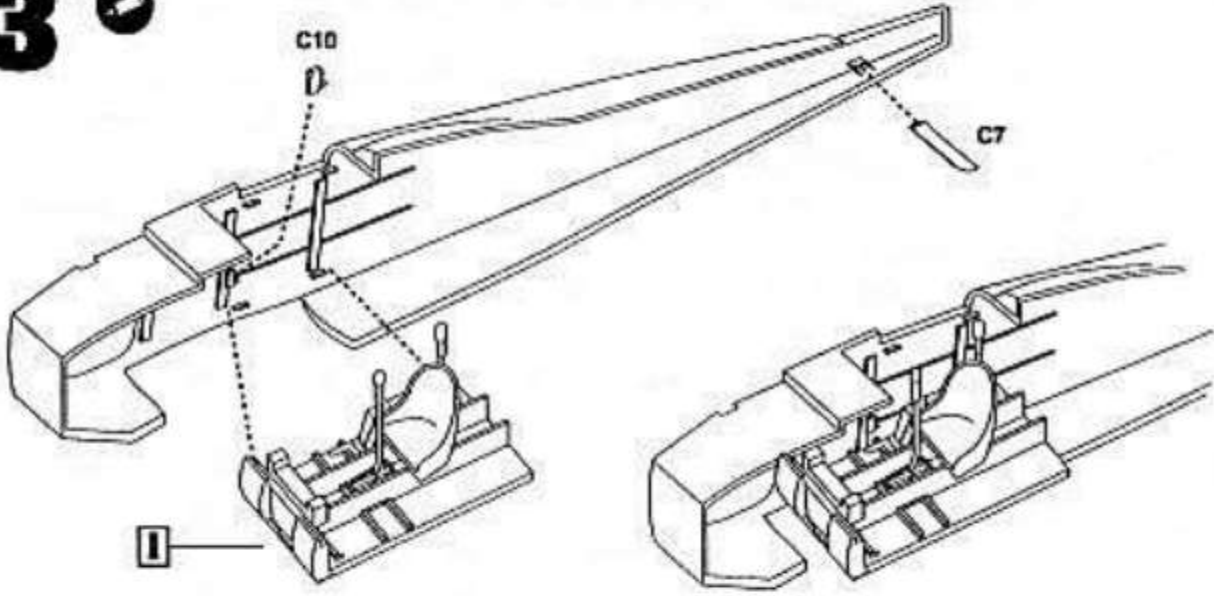

4

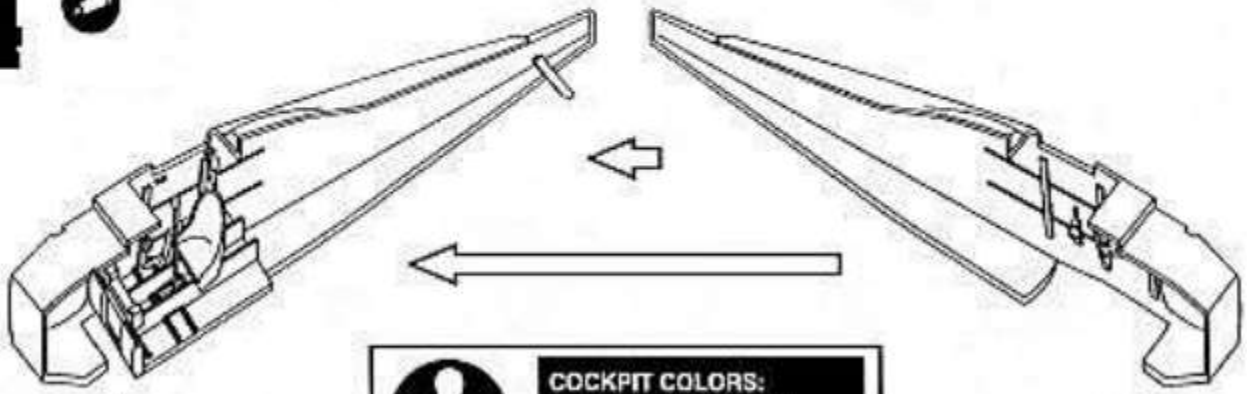

COCKPIT COLORS:

- sidewalls: dark gray
- instruments: black
- seat & headrest: brown

5

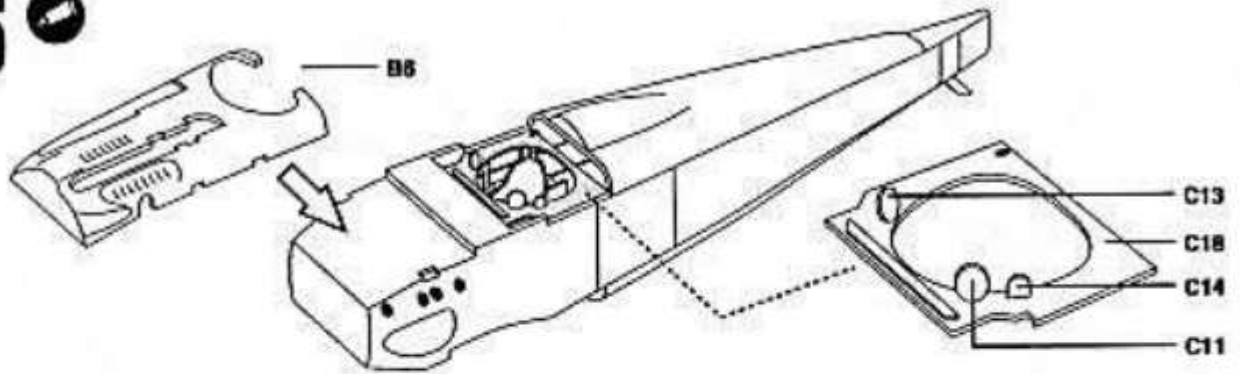

6

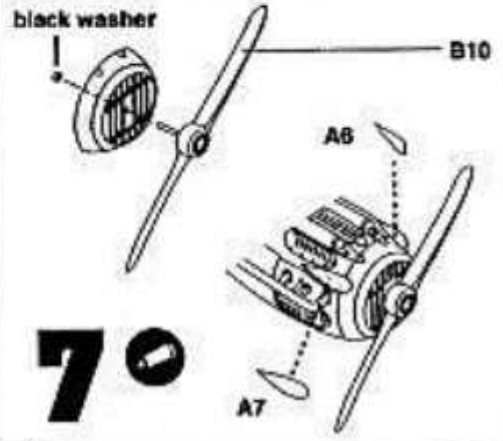
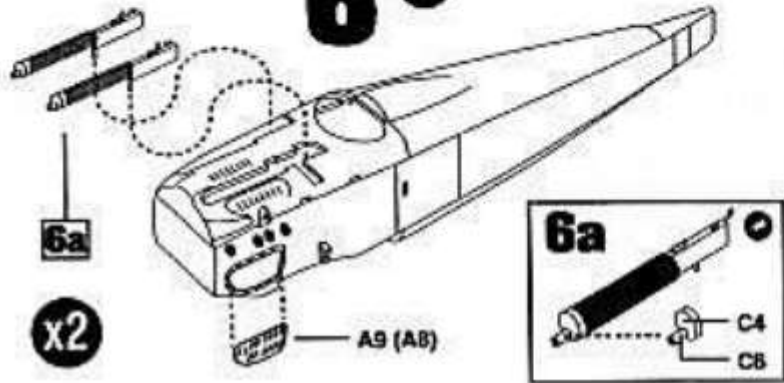

7

8

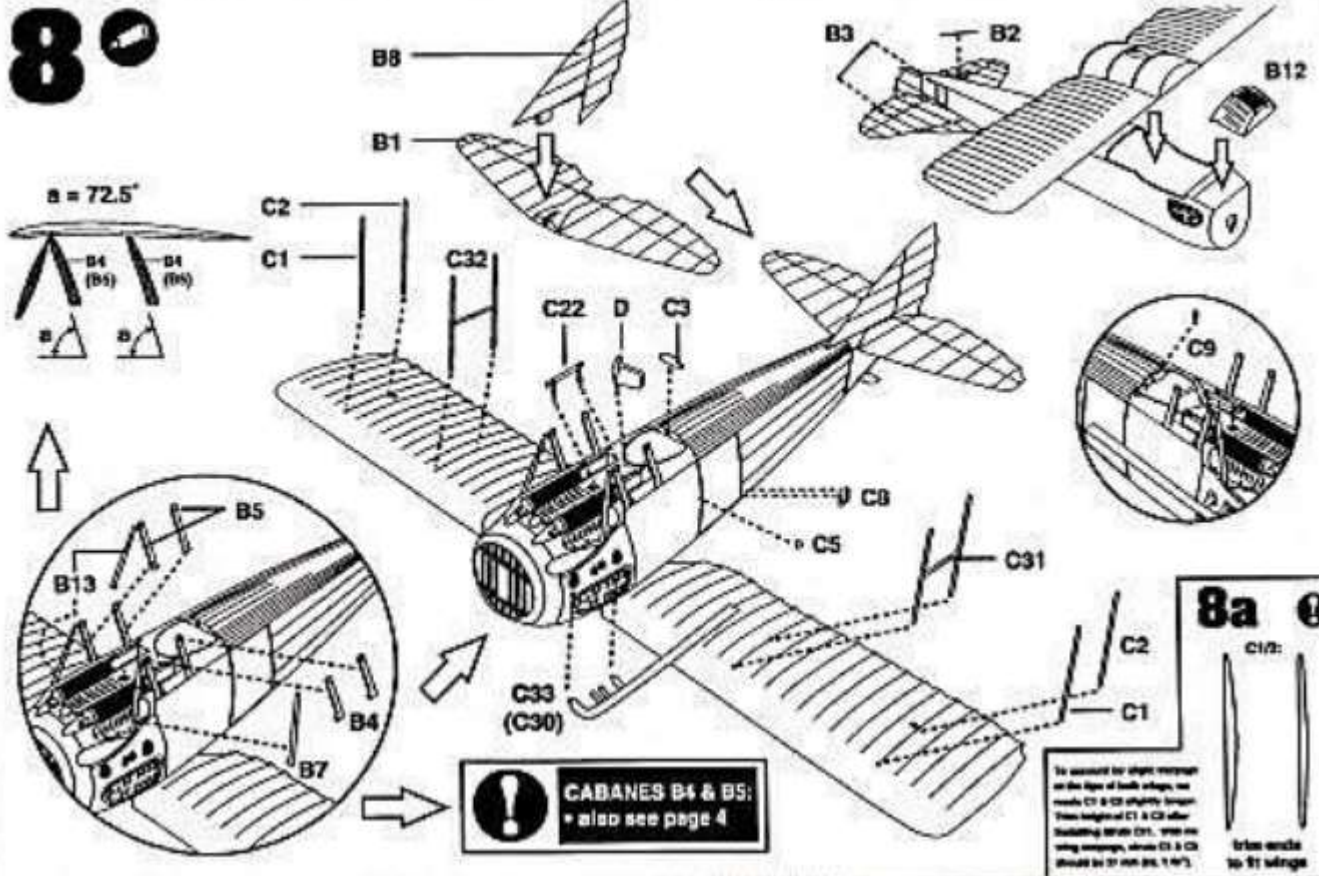

8a



! CABANES B4 & B5:
• also see page 4

To account for slight overhang
on the tips of both wings, we
make C1 & C2 slightly longer
than length of C1 & C2 after
installing B13 & C1. With no
wing overhang, since C1 & C2
should be 71 mm (2.8125"),

trim ends
to fit wings

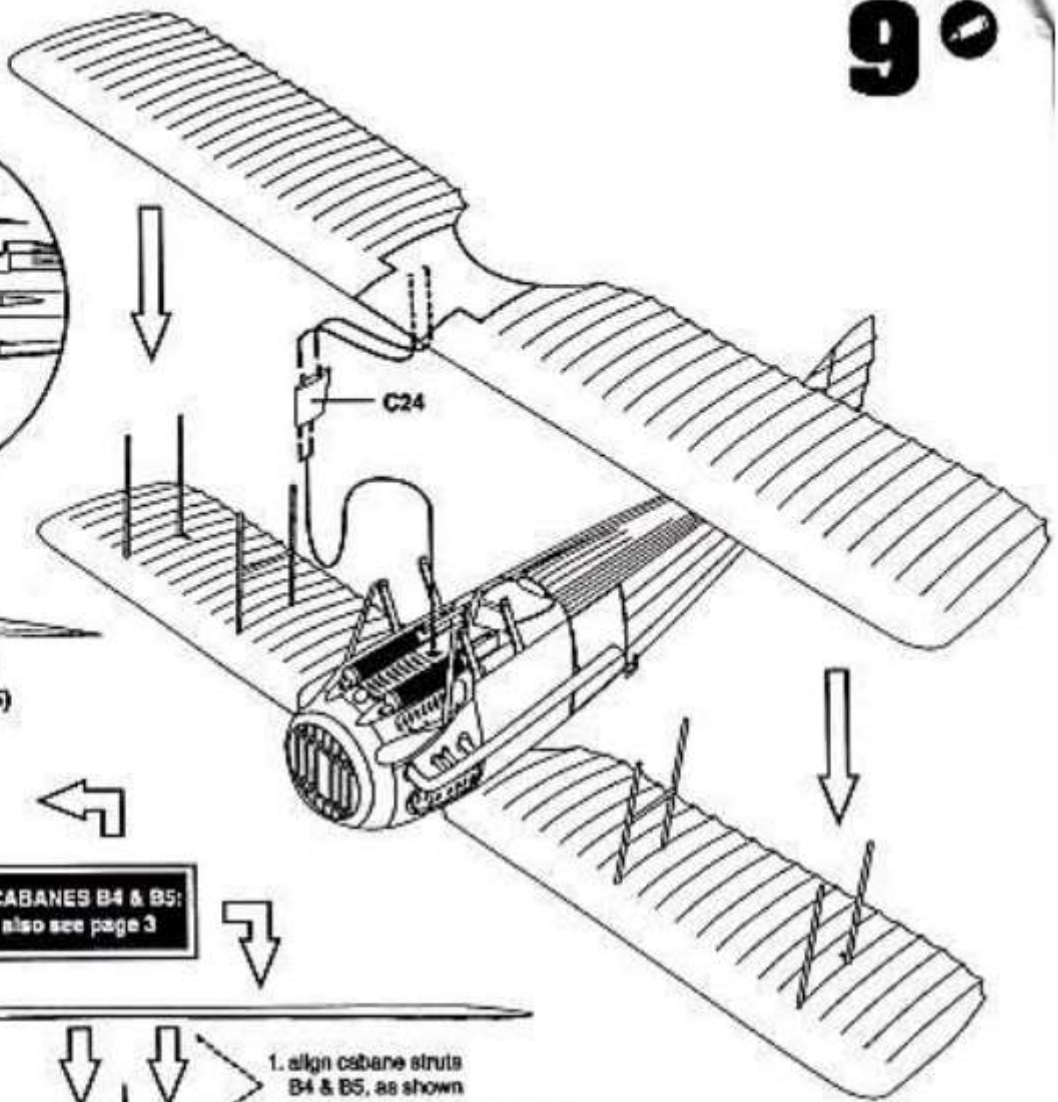

$a = 72.5^\circ$

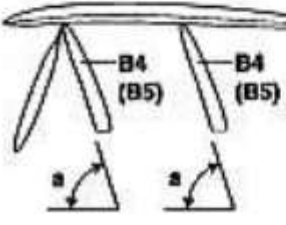

! CABANES B4 & B5:
• also see page 3

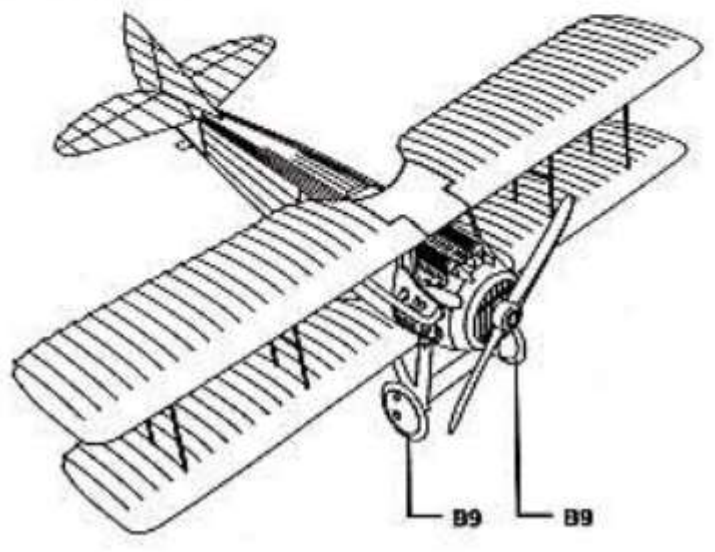
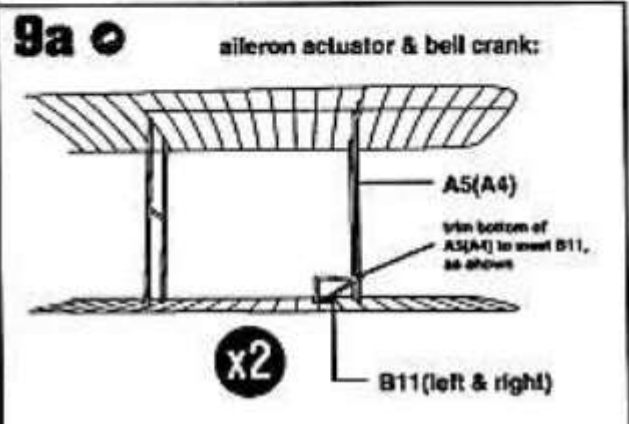
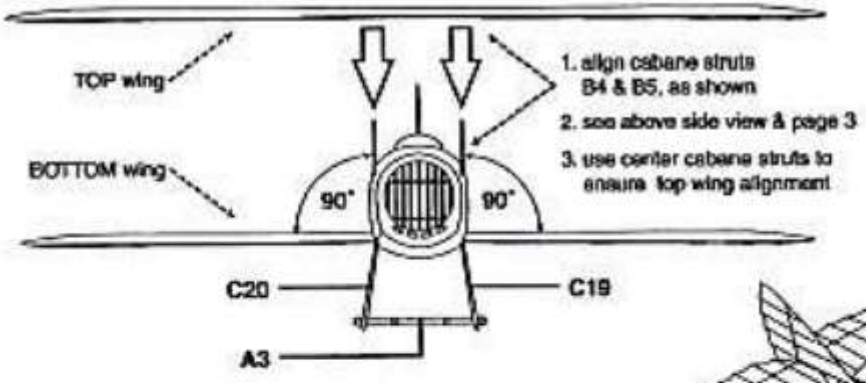

RIGGING

! some details omitted for clarity

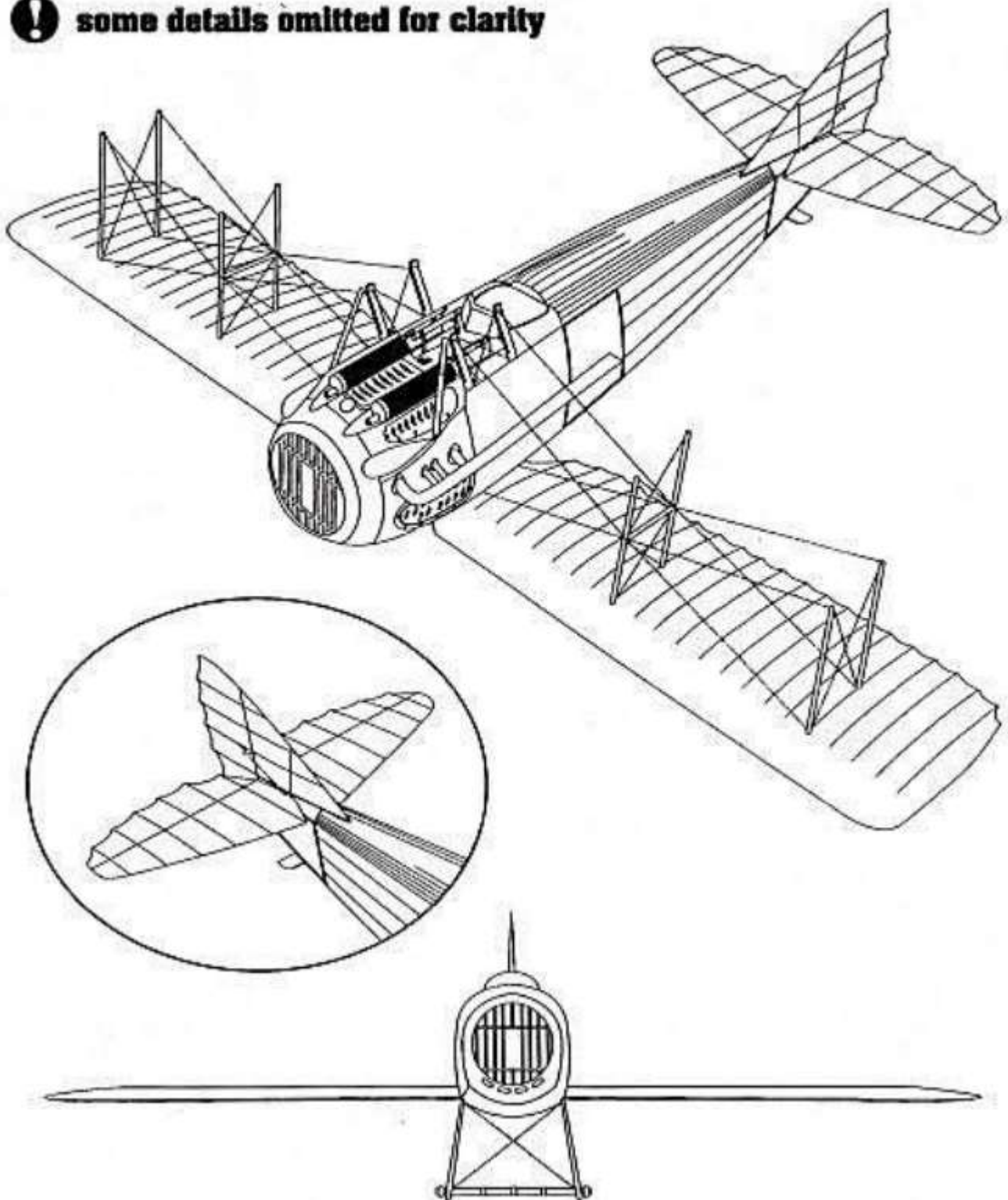

'Aviatic' have produced, as part of their Legend Series, a set for Ltn. Frank Luke, which consist of a resin figure and decal set covering markings for the three Spad XIII C.1 aircraft he was known to have flown. As expected the quality of the figure and decals is excellent. In addition, a booklet is provided which in itself is a stand alone reference to the man and his aircraft. The booklet covers, in detail, the history of Luke's flying career and also has excellent colour profiles of his Spad XIII C.1 aircraft, which were manufactured by either Blériot Aéronautique (Bleriot) or by the Société des Avions Bernard (Bernard).

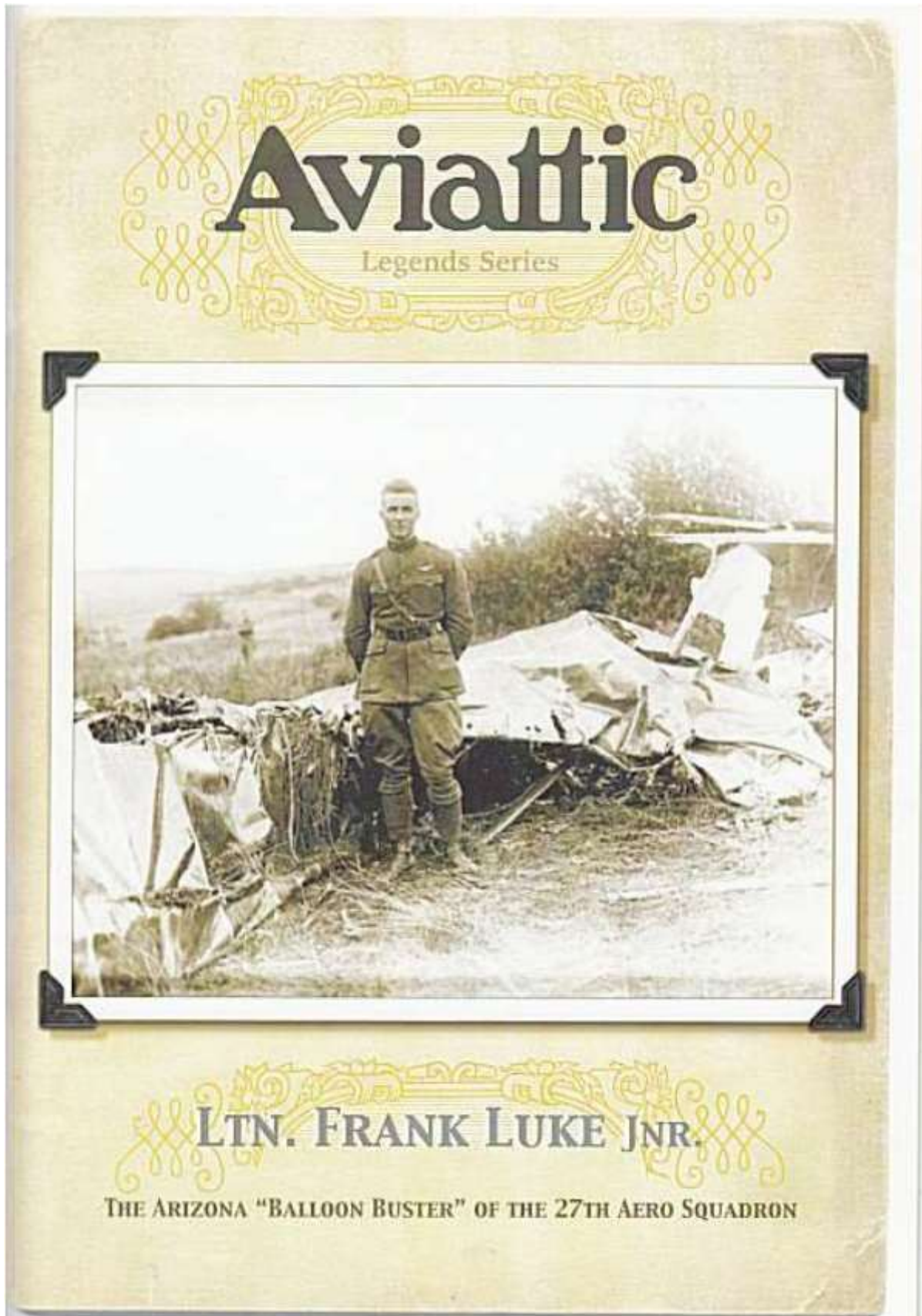

For this build I used the 'Aviatic' decals (on the right) and used only the instrument decals from the sheet supplied with the model kit (on the left).



Below is a shot of the 'Aviatic' resin figure of Lt. Frank Luke Jr. It comes as three parts, the body, head and hands flying holding goggles.



PREFACE

This model represents the Bleriot built Spad XIII C.1, Number 26 of 'C' flight, 27th Aero Squadron, 1st Pursuit Group, based at Rembercourt, which was an advance airfield near Verdun, France during September 1918. The aircraft was flown during 1918 by 2/Ltn. Francis 'Frank' Joseph Anthony Luke Jnr, the renowned 'Arizona balloon buster'.

The pilot :

References:

Osprey - Aviation Elite Units - USAS 1st Pursuit Group by Jon Guttman.

Osprey - Aircraft of the Aces - SPAD XII/XIII Aces of World War 1 by Jon Guttman.

'Aviatic' Legend Series - Frank Luke Jnr booklet.

Online - Aircrewremembered.com.

Much has been written about the Frank Luke Jnr, so this brief will contain just the pertinent facts. Francis Joseph Anthony Luke Jnr was born on the 19th of May 1897 to parents Frank and Otilia Luke, an upper class German Catholic family, who settled in Phoenix, Arizona in 1873. He was to volunteer to join the fledgling Air Service when America joined WW1 in April 1917. After his initial training in Texas, he was transferred for flying training to San Diego's North Island. Having passed with 'flying colours' he was promoted to 2/Ltn and in March 1918 was posted for further training to Issoudun in northern France. On July the 25th Luke was posted to the 27th Aero Squadron (CO Major Harold Hartney), 1st Pursuit Group, which was based at Rembercourt near Verdun, France. Despite not 'fitting in' with his fellow pilot's, Luke started to show his prowess in the air, especially in the particularly dangerous occupation of shooting down enemy observation balloons, normally accompanied by his wingman, Joseph Frank 'Fritz' Wehner. On the 18th of September, Joe Wehner was shot down and killed whilst covering Luke on a balloon busting mission. The loss of Wehner affected Luke deeply. On the 29th of September Luke set off on a balloon busting mission aiming to shoot down three enemy observation balloons in quick succession. During this mission he was mortally wounded in the chest and force landed his Spad XIII C.1 near Mervaux, Lorraine. Despite his wound he managed to get out of the aircraft and made it as far as a stream nearby. As German infantry closed in Luke fired his service Colt 1911 at them before he died. He is buried at the Meuse Argonne American cemetery and Memorial, Lorraine, France. Frank Luke was just 21 years old.

During service he was awarded the Medal of Honour, Distinguished Service Cross 1 and 2 and the War Merit Cross (Italian).

Confirmed victories (4 aircraft and 14 observation balloons):

September 12th 1918 - Observation balloon - near Marieulles.

September 14th 1918 - Observation balloon - near Buzy.

September 14th 1918 - Observation balloon - near Boinville.

September 15th 1918 - Two observation balloons - near Boinville.

September 15th 1918 - Observation balloon - near Chaumont.

September 16th 1918 - Observation balloon - near Reville.

September 16th 1918 - Observation balloon - near Romagne.

September 18th 1918 - Two observation balloons - near Mars la Tour.

September 18th 1918 - Two Fokker D.VII - near St. Hilair.

September 18th 1918 - Halberstadt C - near Jonville.

September 28th 1918 - Observation balloon - near Betheniville.

September 28th 1918 - Hannover CL - near Monthainville.

September 29th 1918 - Three observation balloons - near Avocourt.

2/Ltn. Francis 'Frank' Joseph A. Luke Jnr

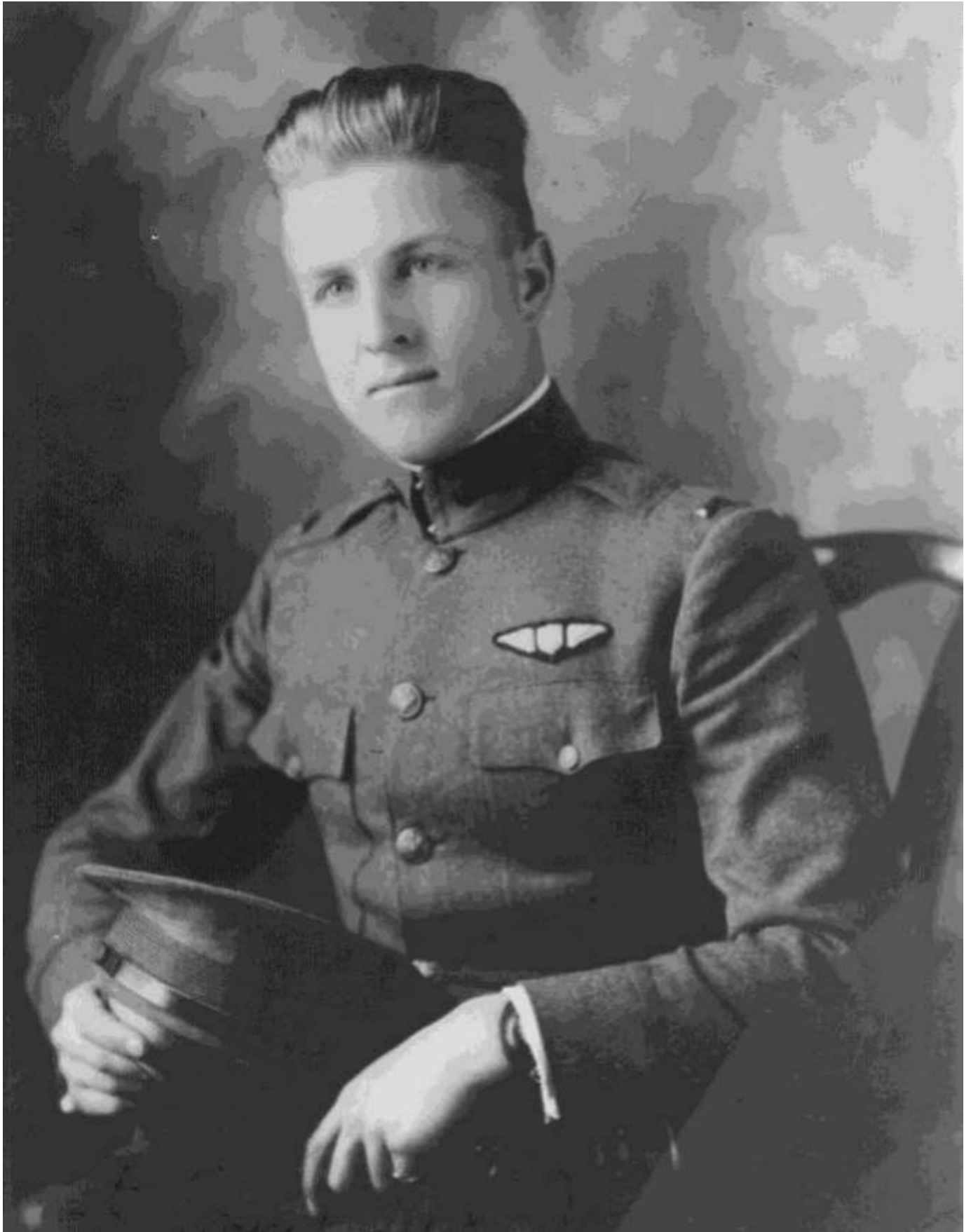

The aircraft:

References:

Osprey - Aircraft of the Aces - SPAD XII/XIII Aces of World War 1 by Jon Guttman.

Osprey - Aviation Elite Units - USAS 1st Pursuit Group by Jon Guttman.

'Aviatic' Legend Series ATT01 - Frank Luke Jnr booklet.

Restoration of Spad XIII C.1, Serial No.4377 - <http://memorial.flight.free.fr/indexuk.html>

This model represents Frank Luke's Bleriot built Spad XIII C.1, Number 26 of 'C' flight, 27th Aero Squadron, 1st Pursuit Group, based at Rembercourt, near Verdun, France during September 1918. The term SPAD is short for the 'Société de Production des Aéroplanes Deperdussin to Société Pour L'Aviation et ses Dérivés', company purchased by Louis Bleriot. The actual serial number of this particular aircraft is not known for sure, as various sources show it as being one of many possibilities. I chose to use serial number 15310, as supplied on the 'Aviatic' decal sheet. The number '26' allocated to this aircraft was also added to Spad Serial No.S7805, which was being prepared for Frank Luke, but never actually flown by him. This model does not represent the aircraft in which Luke was shot down, which was a 'Bernard' built Spad, serial No.S7984. The Spad was compact and small in size when compared to many single seat fighters of that era. However it proved to be robust and fast, especially in a dive. It was flown not only by the French, but also by many other nations, including the British, American and Italian air forces. Many aces flew the Spad XIII, amongst which were the American Eddie Rickenbacker and the Italian Francesco Barraca.

Specifications:

Wingspan - 8.25 m (27' 1"), **Height** - 2.6 m (8' 6 1/2"), **Length** - 6.25 m (20' 6")

Engine - Hispano-Suiza 8BE 8 cylinder V-type inline, 220hp (164 kW)

Armament - Two .303 (7.7 mm) Vickers machine guns or two Marlin M1917/1918 machine guns or one .303 (7.7 mm) Vickers machine gun and one Vickers 11 mm 'Balloon' Machine Gun.

Weight - Empty weight 856 kg (1,245 lbs) - Maximum take-off weight 845 kg (1,863 lbs)

Ceiling - 6,650 m (21, 815')

Endurance - 276 km (171 miles)

Speed - Maximum 218 km/h (117 knots, 135 mph) at 2,000 m (6,560')

The photograph below shows Frank Luke alongside Spad XIII C.1, number 26.



Below is the colour scheme and markings for '26', as shown in the booklet supplied with the 'Aviatic' Frank Luke ATT01 decal set

Aviatic *Legends Series* Lt. Frank Luke Jnr., 27th Aero Squadron

The "number 26" Blériot-built C Flight, flown by Luke July-September 1918, French applied national markings, Parchment-tipped Grasshopper propeller.

Possible alternative serials for "number 26" - included on the decal sheet

- 15111
- 15113
- 15161
- 15231
- 15265
- 15292
- 15349

The strip views of the rudder and wing cockades show a darker blue which could have been applied over the (probable) factory-applied lighter blue. These areas are supplied as over-lay decals on the small supplementary decal sheet.

ATTL01 ©Aviatic & Pheon Decals 2015

PART 1 - THE MODEL

(Modifications or corrections)

1. General preparation:

Some modellers work the various pieces whilst they are still attached to the main sprue, but I prefer to remove the pieces first so that I can clean them up more easily. However delicate pieces can easily be damaged when being removed. When parts are cut from the sprues, care should be taken as they can either break or get stressed at the cut point, which causes 'white' stress and/or deforming. For plastic kits, I use fine sprue cutters to cut away the kit part, not too close to the part, then sand off the tag. When I cut resin parts away from their mold blocks, I use a fine cutting saw, which has a more gentle cutting action.

There are some fine moulding lines around items, but they are only slight and are easily removed using a sharp blade or sanding stick. I use a new scalpel blade to gently scrape off the mould lines. Some of the model items like the parts for the cockpit are very small and can easily 'fly off' when being handled, so take care.

Remember to drill any holes needed for rigging or control lines - refer to the relevant pages and diagrams in the kit instruction manual.

Once the items have been removed from the sprue and prepared, they should be gently washed in warm, soapy water, to remove any handling 'grease' or mould release agent remaining on the items. I use an old toothbrush to do this. Once dry they can be primed ready for painting. Primer can be applied by brush, airbrush or from aerosol cans. Although not the cheapest method to prime items, I prefer to use Tamiya's fine surface primer aerosol (light grey). This has a good coverage as the base primer for acrylics. Take care when spraying the primer as if you apply too much it will result in 'pooling' or 'runs', which would then need to be removed once the primer has dried. Make sure you spray in a well ventilated area or preferably, if you have one, use an extractor booth.

To hold items for priming I use self locking tweezers or carefully insert a toothpick into the item or I use a small piece of sticky putty, such as 'Blu Tack' or 'UHU White Tack', on the end of a toothpick. Once applied the primer dries quickly, one of the main advantages of using acrylic paints rather than enamels or oil paints.

There are always things the modeller will want to either correct or modify a model. For this model there are a few things I decided to work on, before the main build was started. These are detailed in the following pages.

2/3/4. Aileron, Elevator and Rudder - animation:

The Spad only had ailerons fitted to the upper wing. The two aileron, elevator and rudder are molded as part of their main assemblies and such are fixed in position.

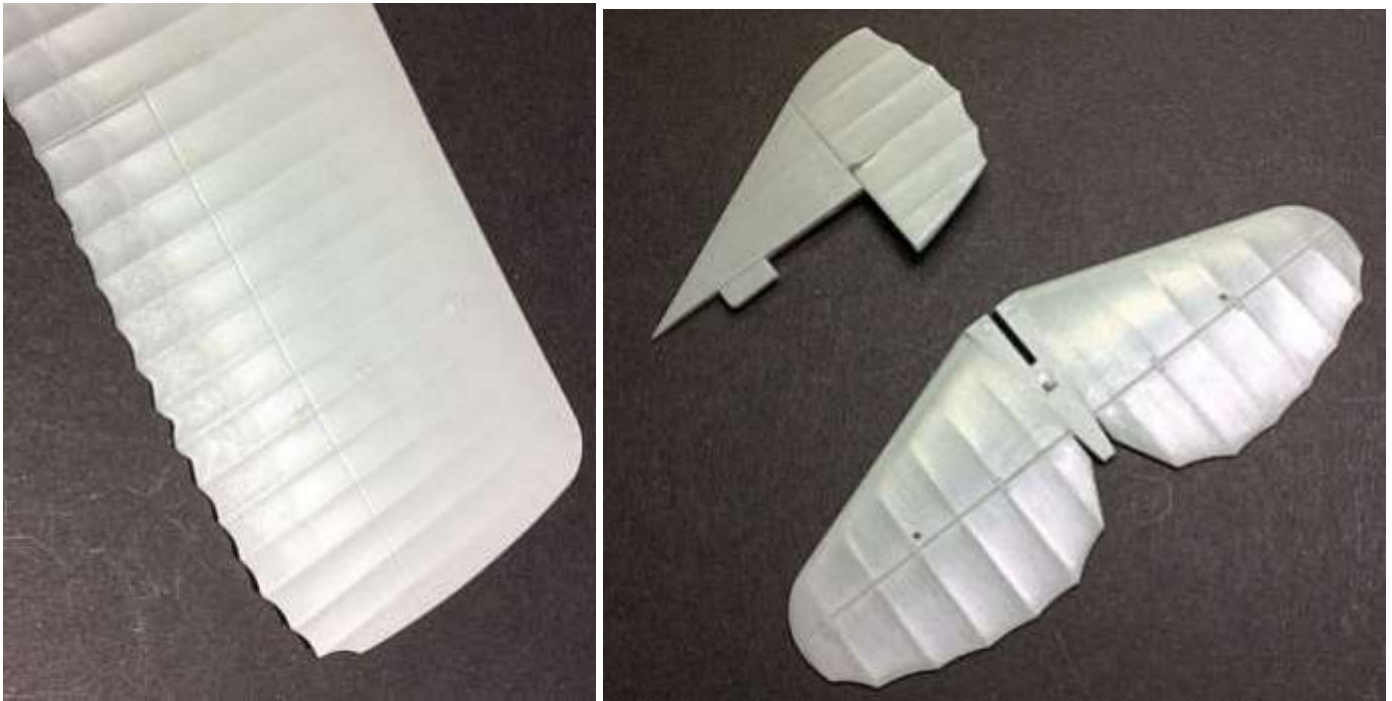

In order to display these flight control surfaces in various positions, they need to be modified. Using a modelling razor saw and using the pre-molded separation lines as guides, I carefully cut through each flight control surface until they could be separated from the main assembly. Each cut surface was sanded flat, checking to make sure that when together, there were no significant gaps showing.

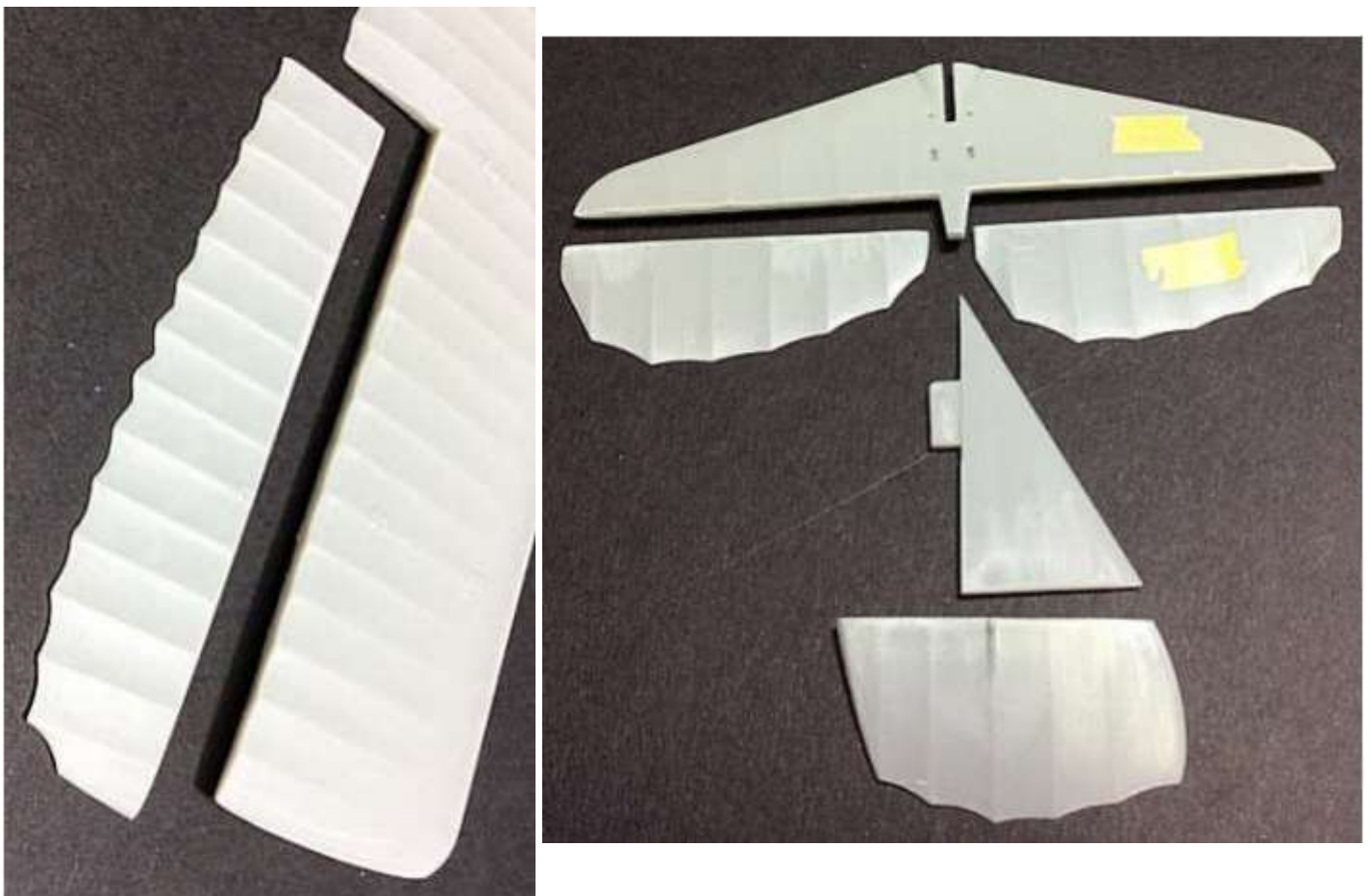

Using a 0.6 mm diameter drill, holes were drilled into the upper wing aileron positions (x3 each), the two elevator positions in the tailplane (x3 each) and the rudder position on the fin (x2).

A short length of 0.5 Brass rod (Albion Alloy's BW05) was inserted into hole and secured using thin CA adhesive.

Using these tubes as a guide, holes of 06 mm diameter were drilled into the leading edges of each aileron (x3), each elevator (x3) and the rudder (x2).

Test fit (dry) each control surface to its location, bending the control surface on the tubes, to its final desired position. If there are any unacceptable gaps found around the control surfaces, they can be filled using glued on plastic card, which can then be sanded into the correct shape/profile.

Remove each control surface and sand the leading edges of the rudder, two ailerons and the two elevators to produce a rounded profile.

NOTE: The rudder, ailerons and elevators will be finally fitted at a later stage in the build.

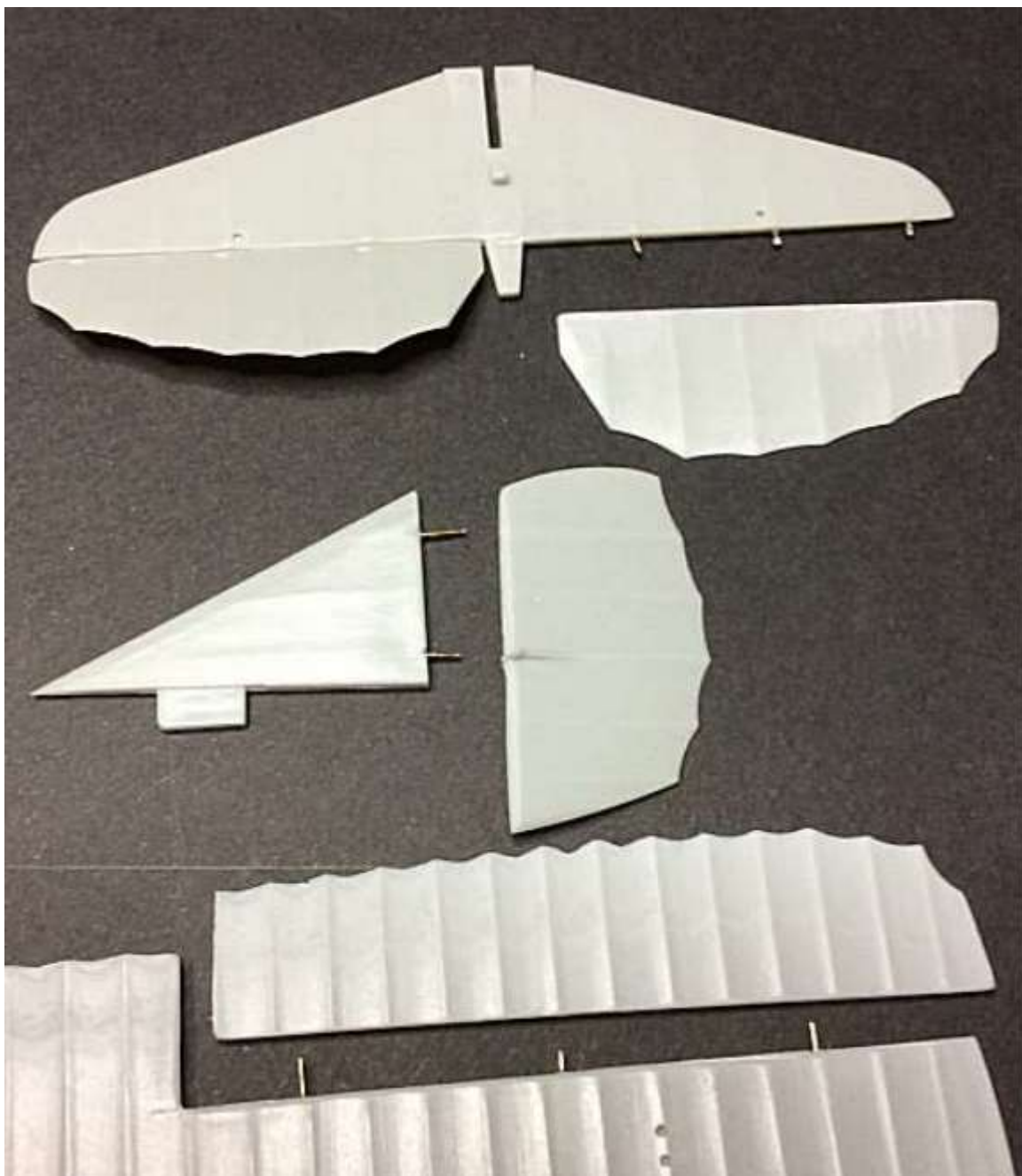

5. Engine cooling:

The Spad XIII C.1 engine required more cooling than most installations of the time. The forward fuselage around the engine was essentially metal panels and enclosed the installed engine. To provide adequate airflow around the engine, many open cooling louvres were located in the upper panel around the two machine guns, the forward underside panel, the two side access panels and on some Spad XIII's, at the bottom of the engine cowl. In addition, the two 'tear drop' shaped cooling blisters had cooling holes in them.

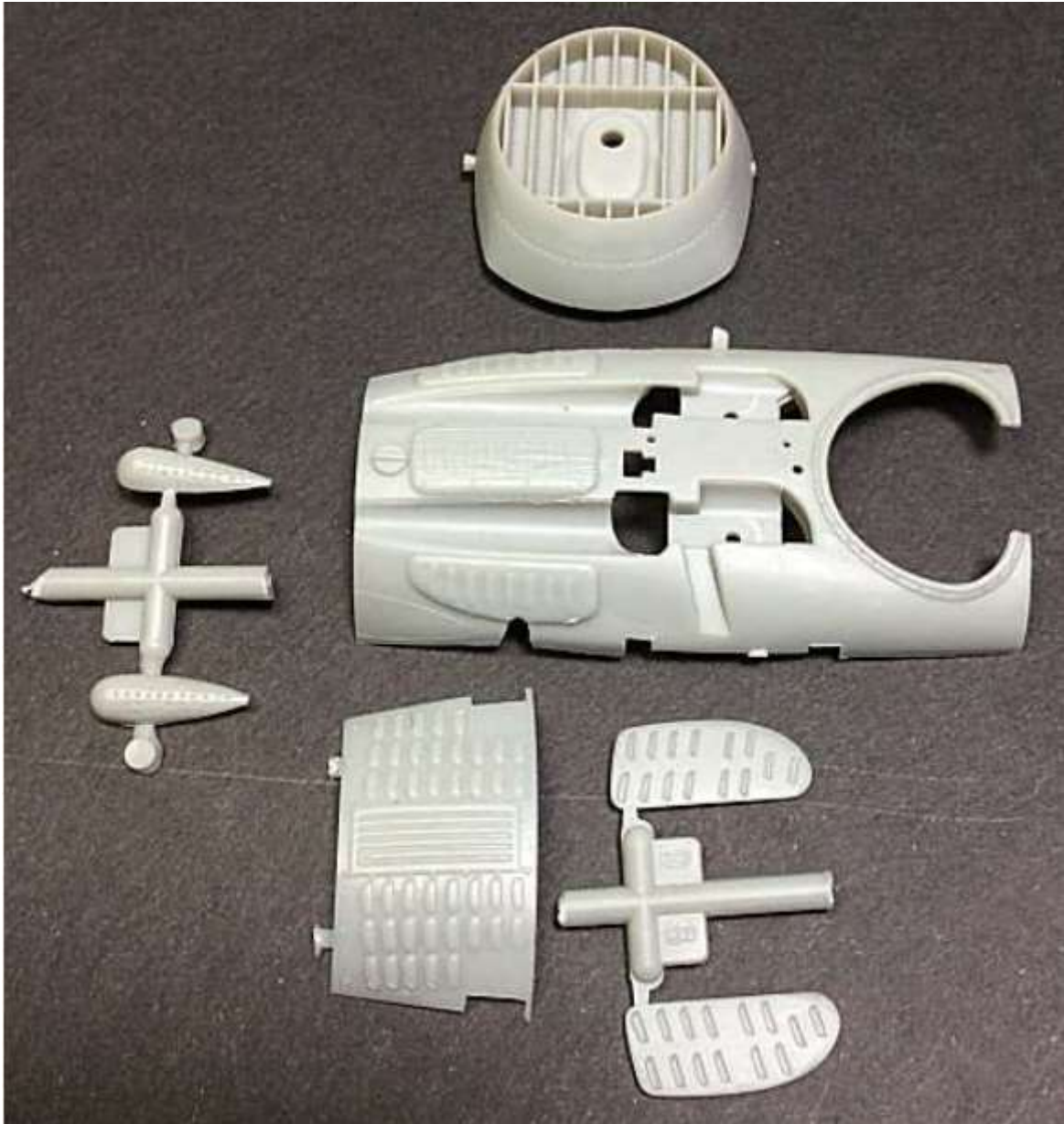

The cooling louvres in the upper panel around the two machine guns are pre-molded solid. To try to recreate the look of open cooling louvres I drilled three 0.5 mm diameter holes along the rear edge of each louvre. Using a 'broken' drill as a reamer, I drilled across the holes from each side, to remove the remaining plastic. Finally I removed any tags etc of plastic using a sharp needle, held in a pin chuck. I then used a 0.5 mm diameter drill to create slight indents around each of the three louvered panels to recreate the fasteners that held the panels in place. These fasteners are pre-molded on the panels but are too small to be seen. Finally I applied a very light coat of the Tamiya Extra Thin cement over the louvres, to smooth out worked areas.



I did not work the louvres on the two side access panels (kit items A8 and A9), as these will not be used on this build, as I will be covering the panel openings with mesh, which was a 'field' modification embodied on many Spad XIII C.1 aircraft. However if you do use these access panels, the louvres can be worked as for the upper panel, described previously.



A drill of 0.3 mm diameter was used to drill out the holes that were pre-molded into the two 'tear drop' cooling blisters.

The cooling louvres on the forward underside panel (kit item B12) were worked as for the upper panel described previously.



6. Engine cowl/radiator detail:

The Spad XIII C.1 engine cowl supplied with kit is of good quality, but is missing the following:

The four cooling apertures in the bottom of the cowl, two equally spaced from the centre line, which were utilised on some Spad XIII C.1 engine cowls.

Operating rods for the radiator shutters.

Radiator drain valve.

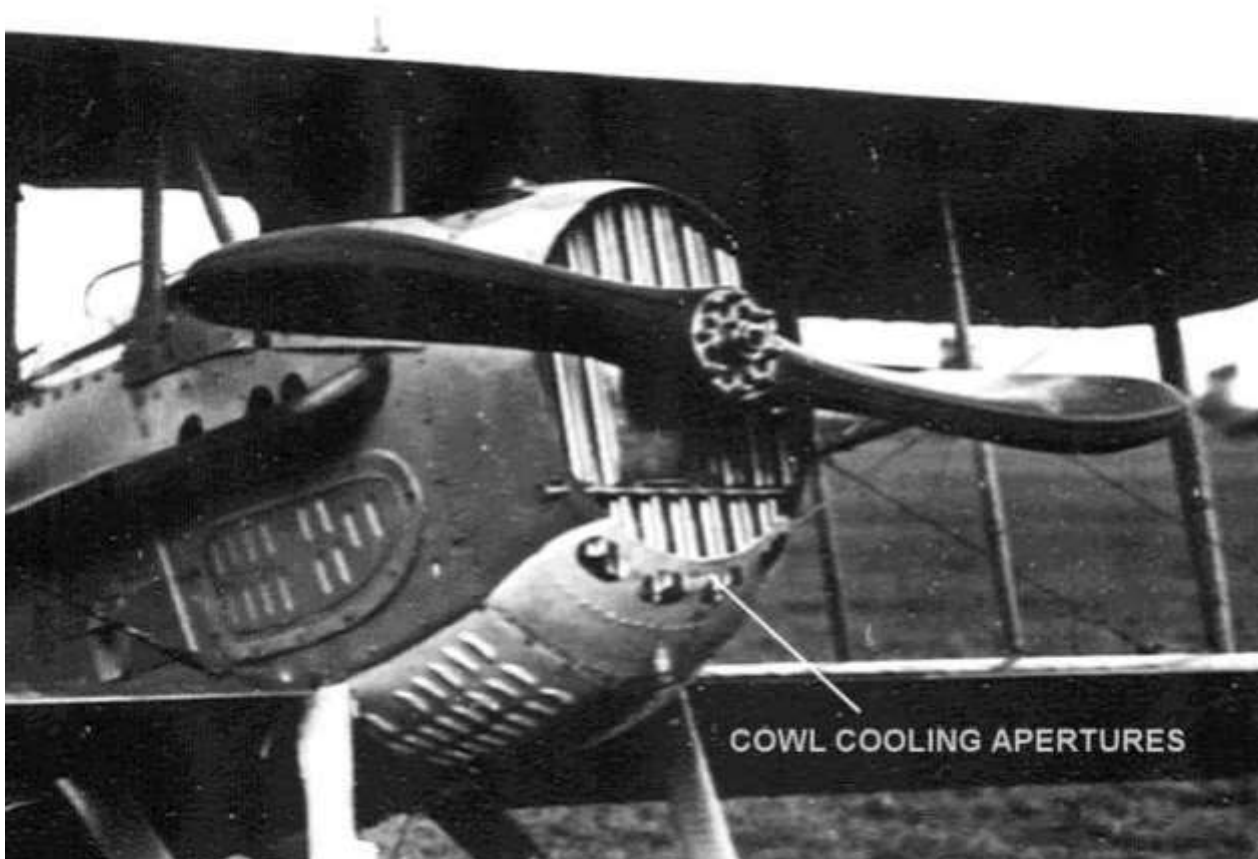

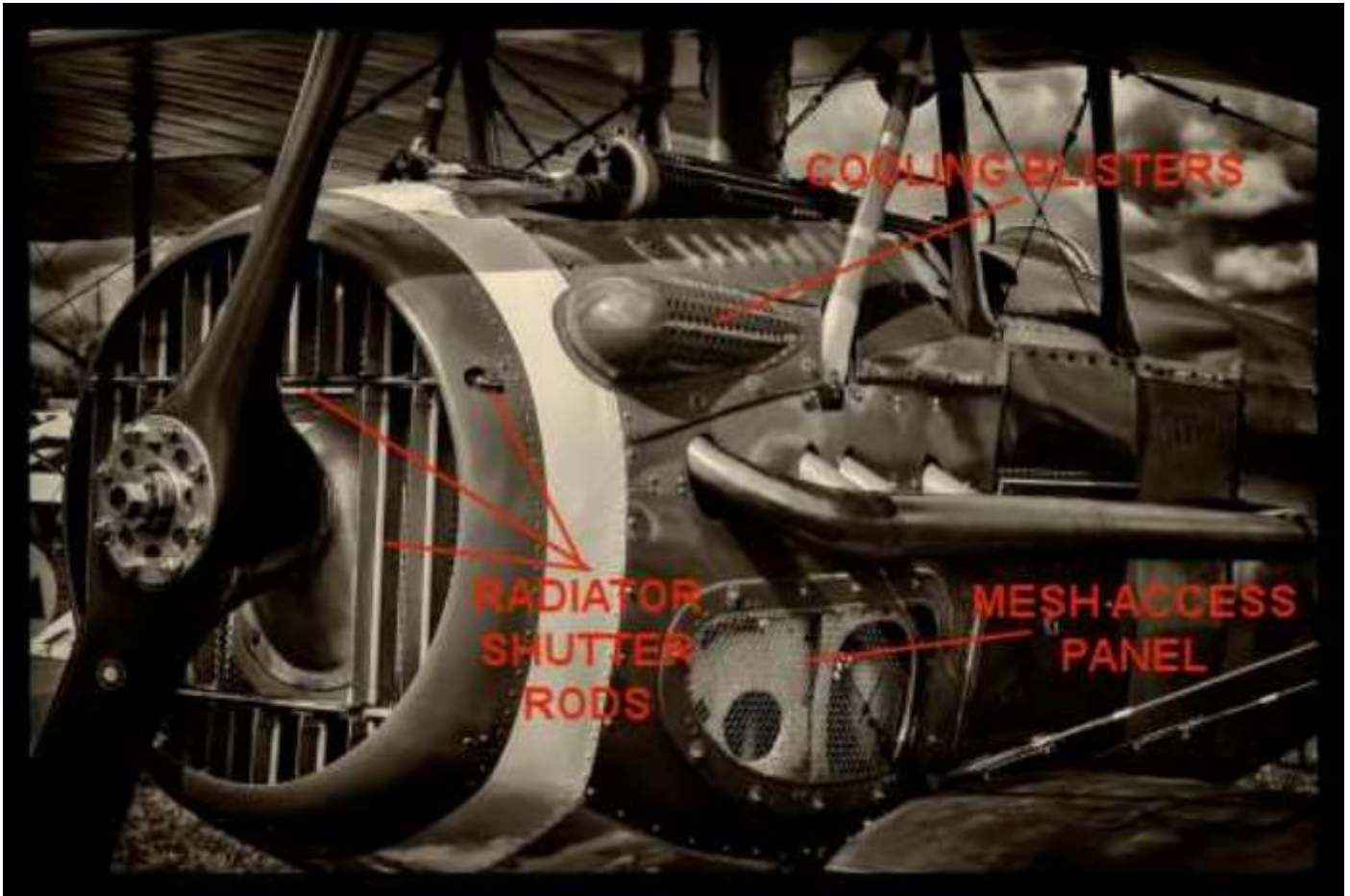

Radiator shutter rods:

The Spad radiator shutters were operated by the pilot from a cable, routed back to the cockpit. When operated the shutters could be moved from closed to fully open, thereby allowing more or less airflow through the radiator, which in turn controlled engine temperature.

First I carefully drilled four 0.6 mm diameter holes, one at each horizontal rod outlet through the engine cowl (see above photos). These were to allow 0.4 mm diameter brass tube (Albion Alloys MBT04) to be passed through from one side to the other. I then cut lengths of the tube for the two horizontal rods and all of the shutter vertical rods, which in actuality were to the right side of each shutter. The horizontal rods were secured in position using thin CA adhesive. The vertical rods were secured in position using PVA adhesive, which allows more time to position the rods correctly.

Cowl cooling apertures:

Many Spad XIII C.1 engine cowls had four 'slots' at the bottom to allow more cooling air into the radiator. To replicate these slots I used a pencil to mark their positions then drilled three holes of 0.6 mm diameter along the centre line of each marked slot. These holes were then drilled out to 1.2 mm diameter. Finally the slots were cut out with a sharp scalpel blade then given a light coat of Tamiya Extra Thin cement, to smooth out the surfaces.

NOTE: For both of the above, take care when drilling through the cowl sides, to ensure you don't break the cowl away or hit the shutter detail.

Radiator drain valve:



The Spad radiator was drained through a valve assembly, which protruded through the bottom centre of the engine cowl. To recreate this valve I first drilled a 1.2 mm diameter hole into the cowl to form an oval aperture. I then secured a short length of Albion Alloys 0.8 mm diameter brass tube (MBT10) into the aperture using thin CA adhesive. Onto the end of this I secured a short length of 1.0 mm diameter brass tube (MBT12) using thin CA adhesive. Once set, I filed this tube down to create a 'collar'. I then opened up the internal diameter of the inside 0.8 mm tube using a 0.4 mm diameter drill and then inserted and secured a short length of 0.4 mm brass tube (MBT04).

Once satisfied, prime the entire cowl to show any imperfections, which can then be rectified.

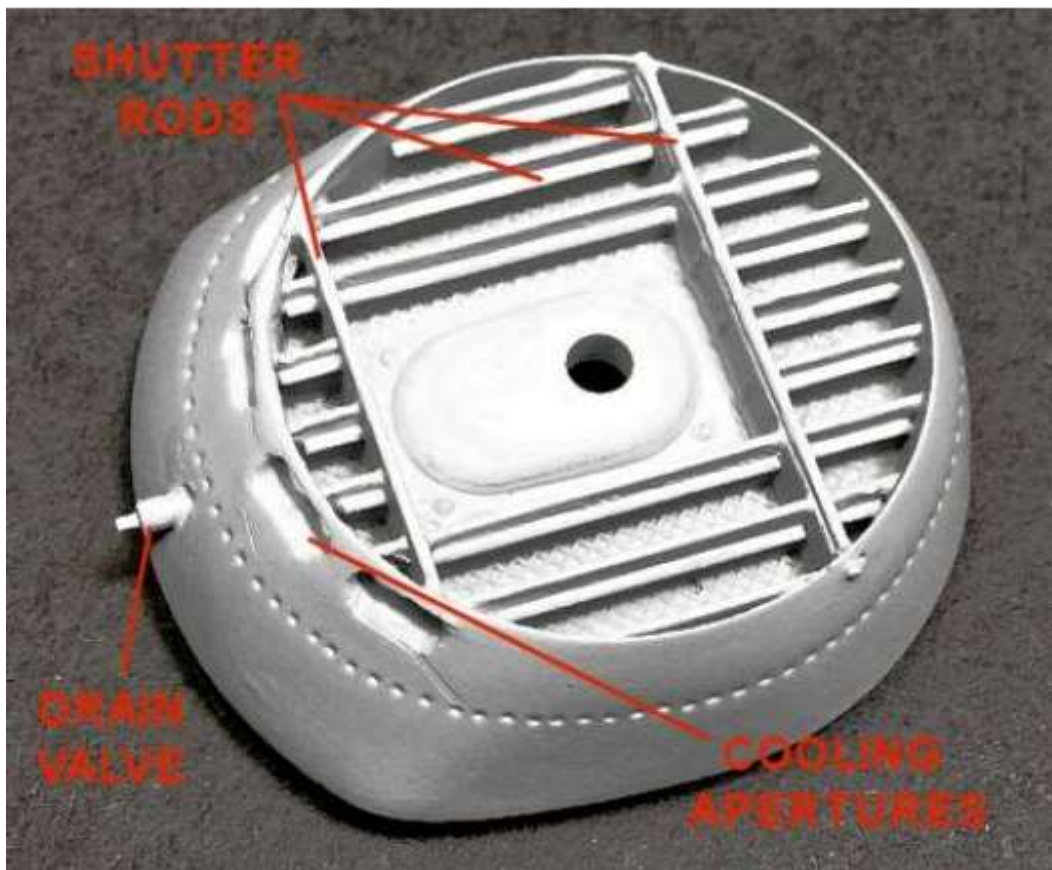

7. Cockpit surround panel:

The cockpit surround panel supplied in the kit is lacking several features. The panel had a wood cross member on the rear of the panel and a headrest support frame, onto which was attached the padded headrest.

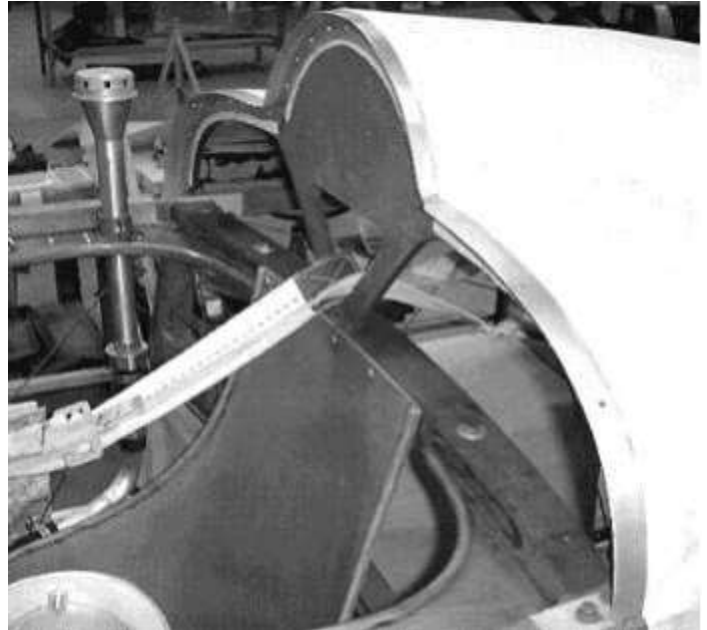

Under the front of the cockpit surround panel and forward from the control column were the ammunition container access panels, running across the cockpit.

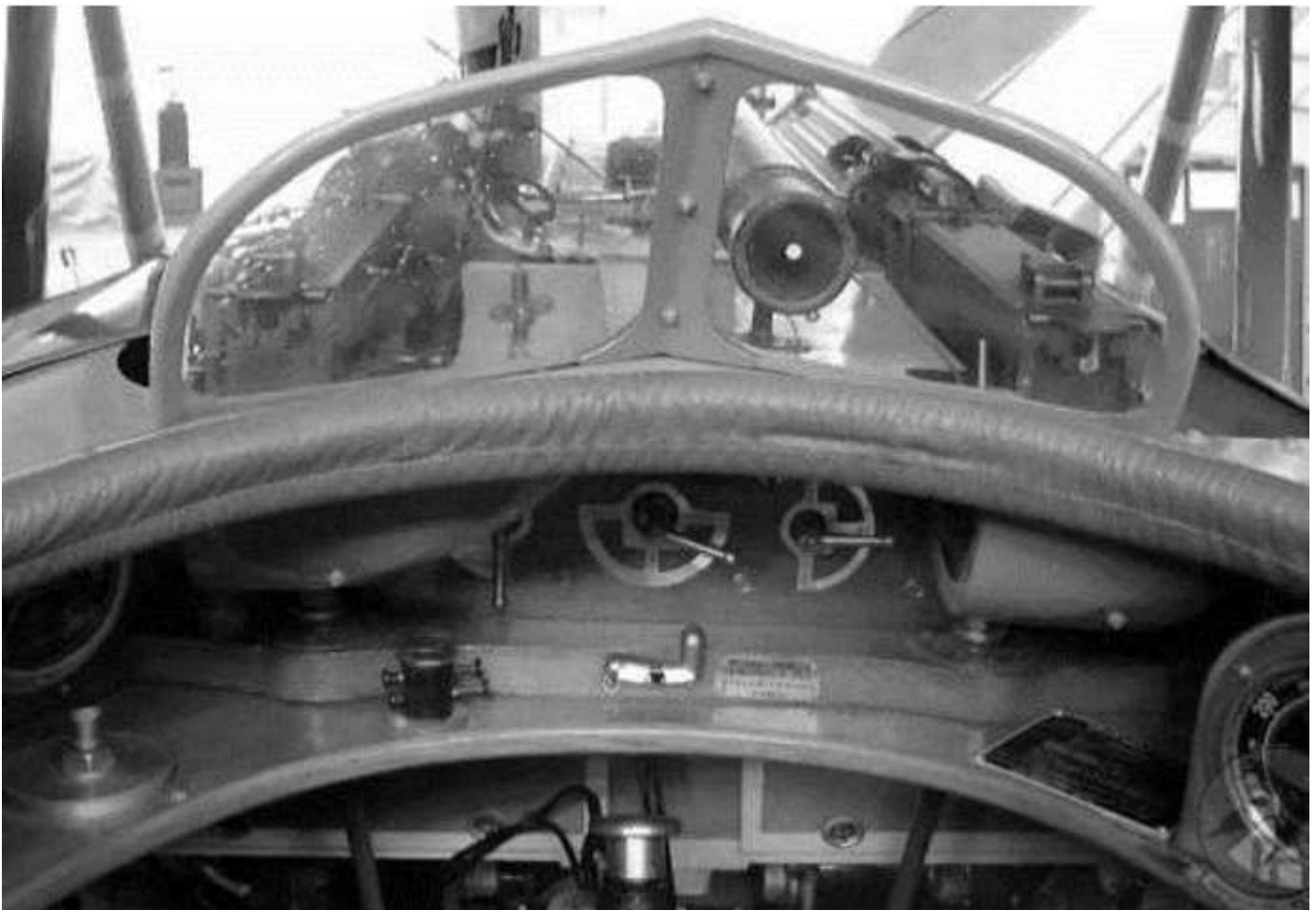

To replicate the headrest support frame:

With the fuselages halves 'dry fitted' together (elastic bands), secure in position the head rest (kit item C3), but only to the left fuselage half. Allow the cement to fully set.

Place in position the cockpit surround panel (kit item C18).

A length of square section plastic rod was cut and secured in position across the rear edge of the cockpit surround panel (kit item C18) and inside the fuselage edges. This would act as the rear support for the bottom of the headrest frame.

A thin card template was cut to fit in the opening in the fuselage at the rear of the surround panel.

The card template was used as a guide to cut the headrest support frame shape from 0.5 mm plastic card.

A pencil was used to mark out the two outer and single central apertures in the headrest support frame, which were carefully cut out with a sharp straight edged scalpel blade.

A second length of square section plastic rod was cut and secured in position across the cockpit surround panel and 0.5 mm away from the previously fitted rear support. This would act as the front support for the bottom of the headrest frame.

NOTE: The headrest support frame will be fitted later in this build.



To replicate the vertical section under the front of the cockpit surround panel (forward from the control column and across the cockpit)

With the fuselages halves 'dry fitted' together (elastic bands) and the cockpit surround panel in position, a strip of 0.5 mm thick plastic card was cut to span the cockpit under the surround panel, to represent the ammunition access panels.

The surround panel was removed and the cut strip secured centrally to the rear face of the 'lip' on the forward face of the panel.

NOTE: The cockpit surround panel will be fitted later in this build.

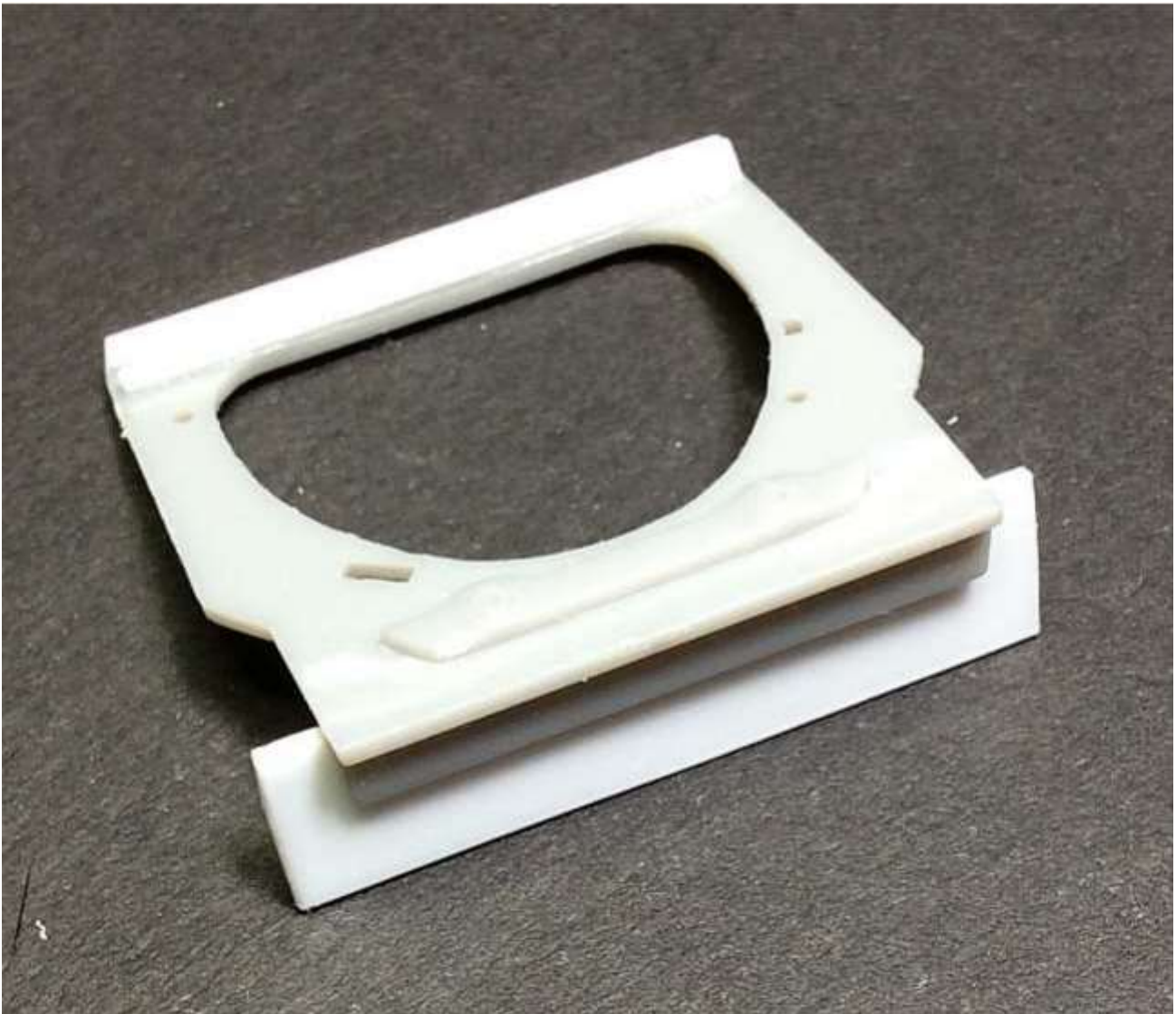

8. Engine bay:

References:

Wikipedia

Restoration of Spad XIII C.1, Serial No.4377 - <http://memorial.flight.free.fr/indexuk.html>

In order to install an engine into this model requires heavy modification of the forward fuselage. This not only means cutting out the existing 'blocked in' fuselage, but also the construction of support frames, side walls and the cockpit bulk head. Also the louvered top decking panel, which in the kit is one piece, will need to be cut into two panels, as the aircraft forward decking panel was removable for engine access.

Some of the following photos are from the restoration of Spad XIII C.1, Serial No.4377, probably the only restored and airworthy Spad XIII. The photos show the engine installation, but not necessarily all of the interconnecting pipe work, such as those running up into the upper wing through the aerodynamic strut.

The following photo's show the engine airframe installation.

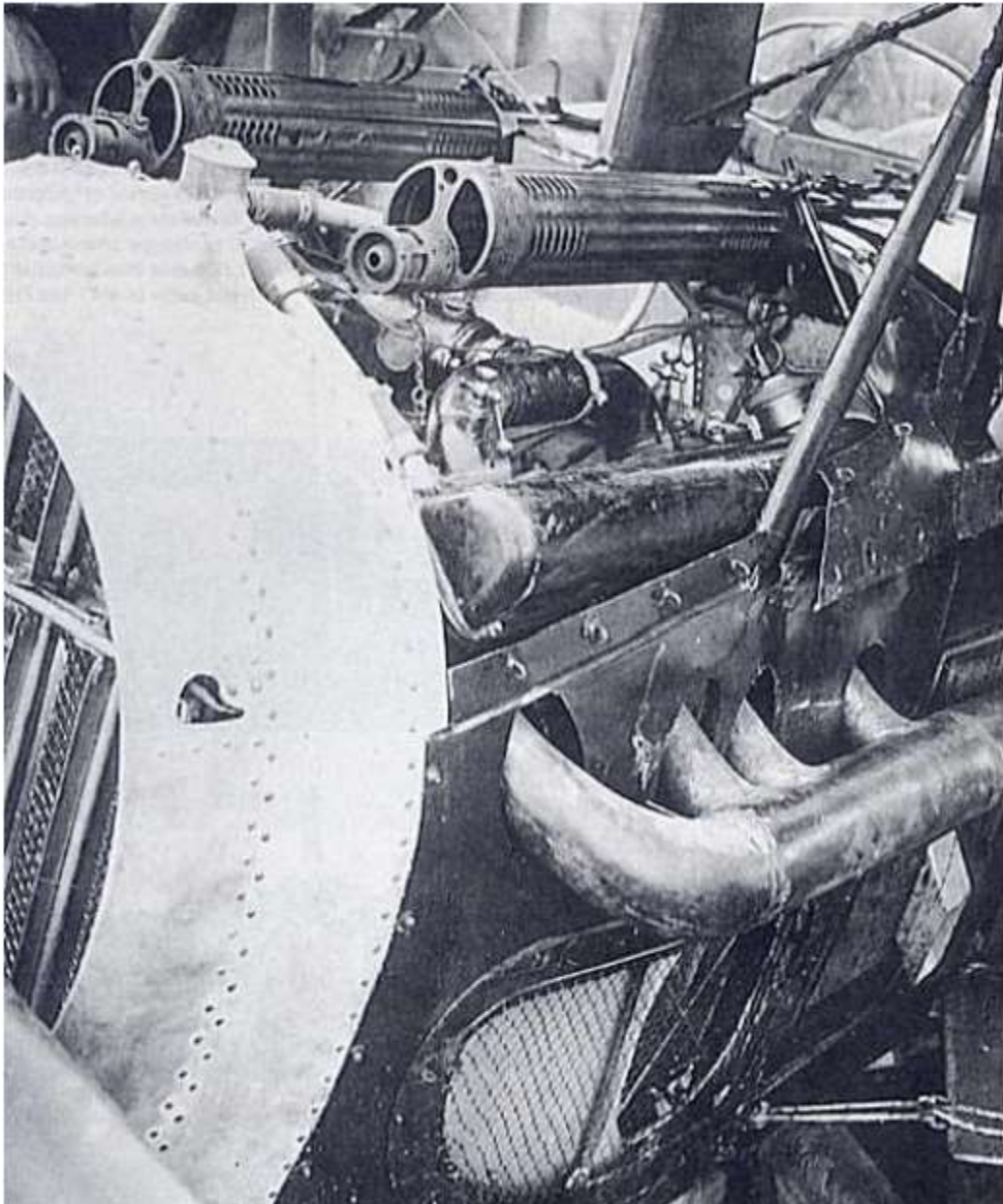

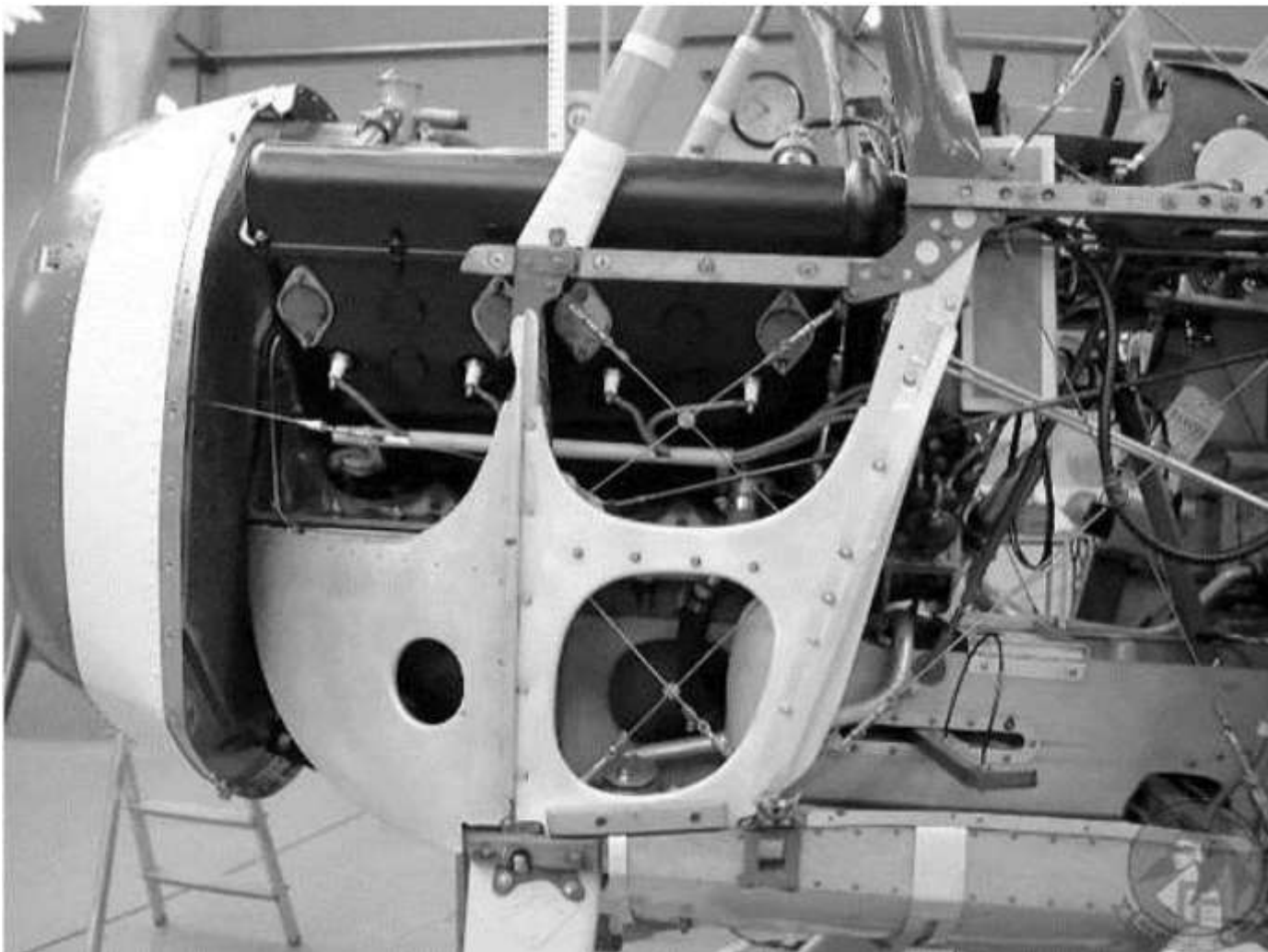
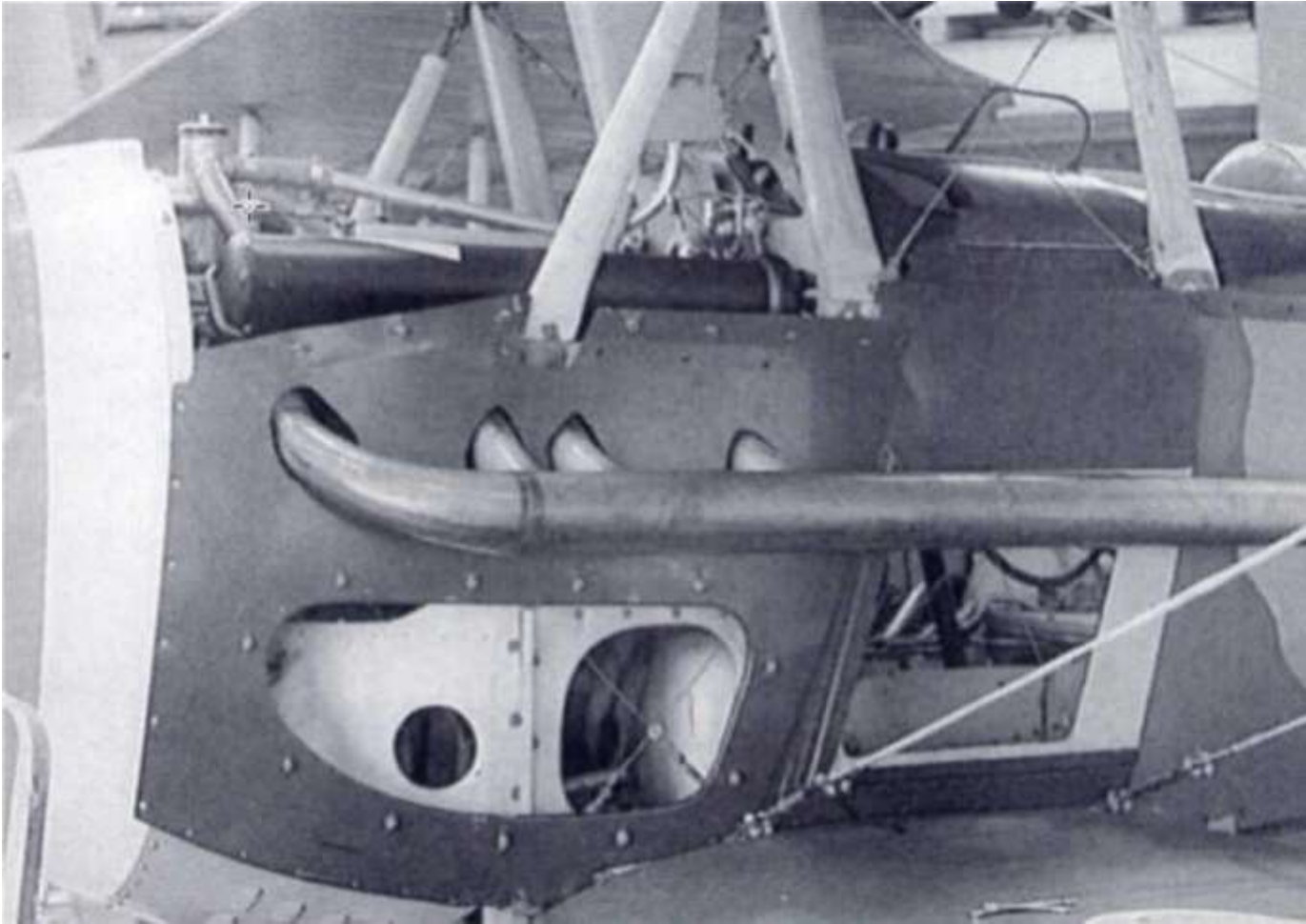

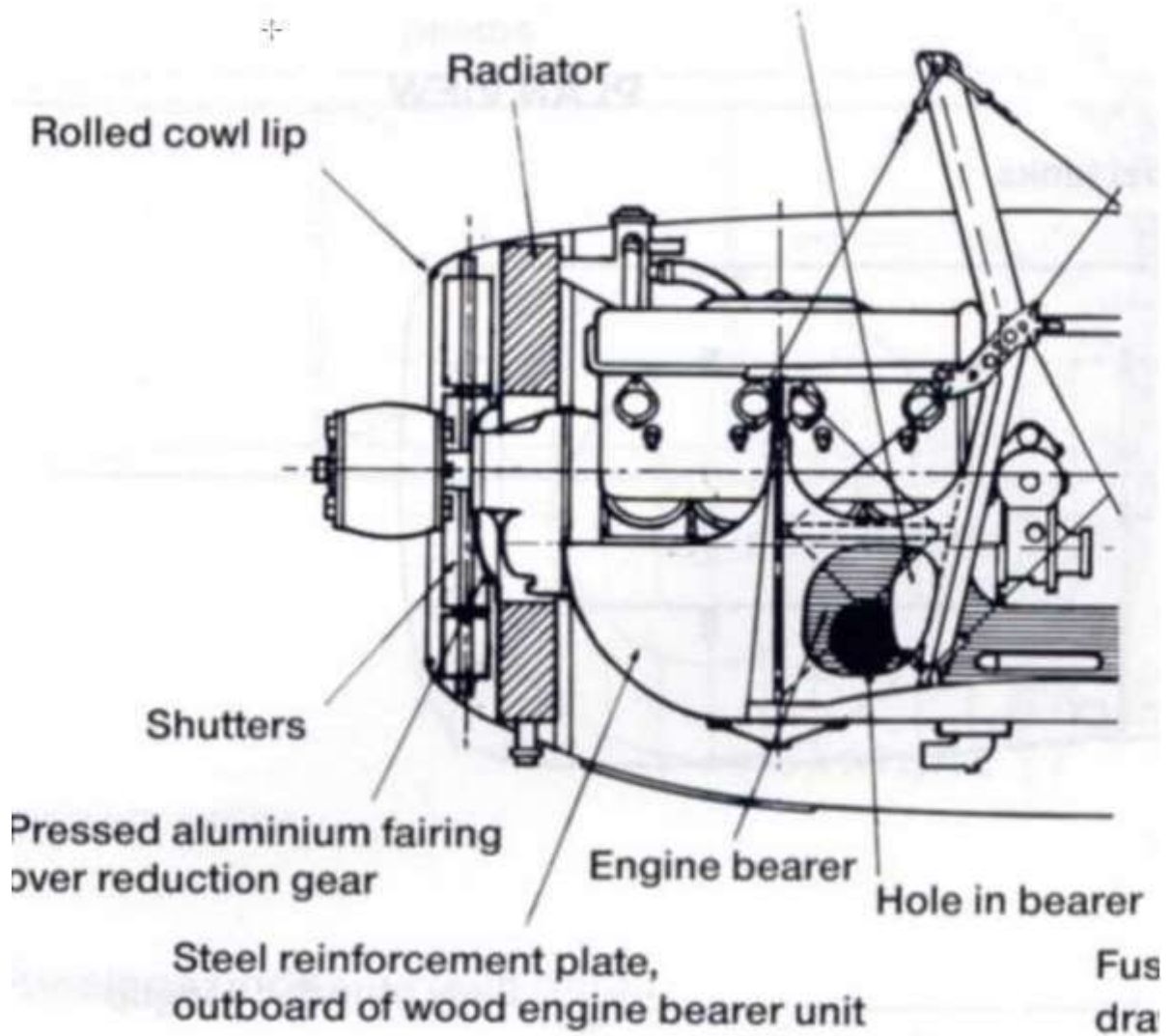
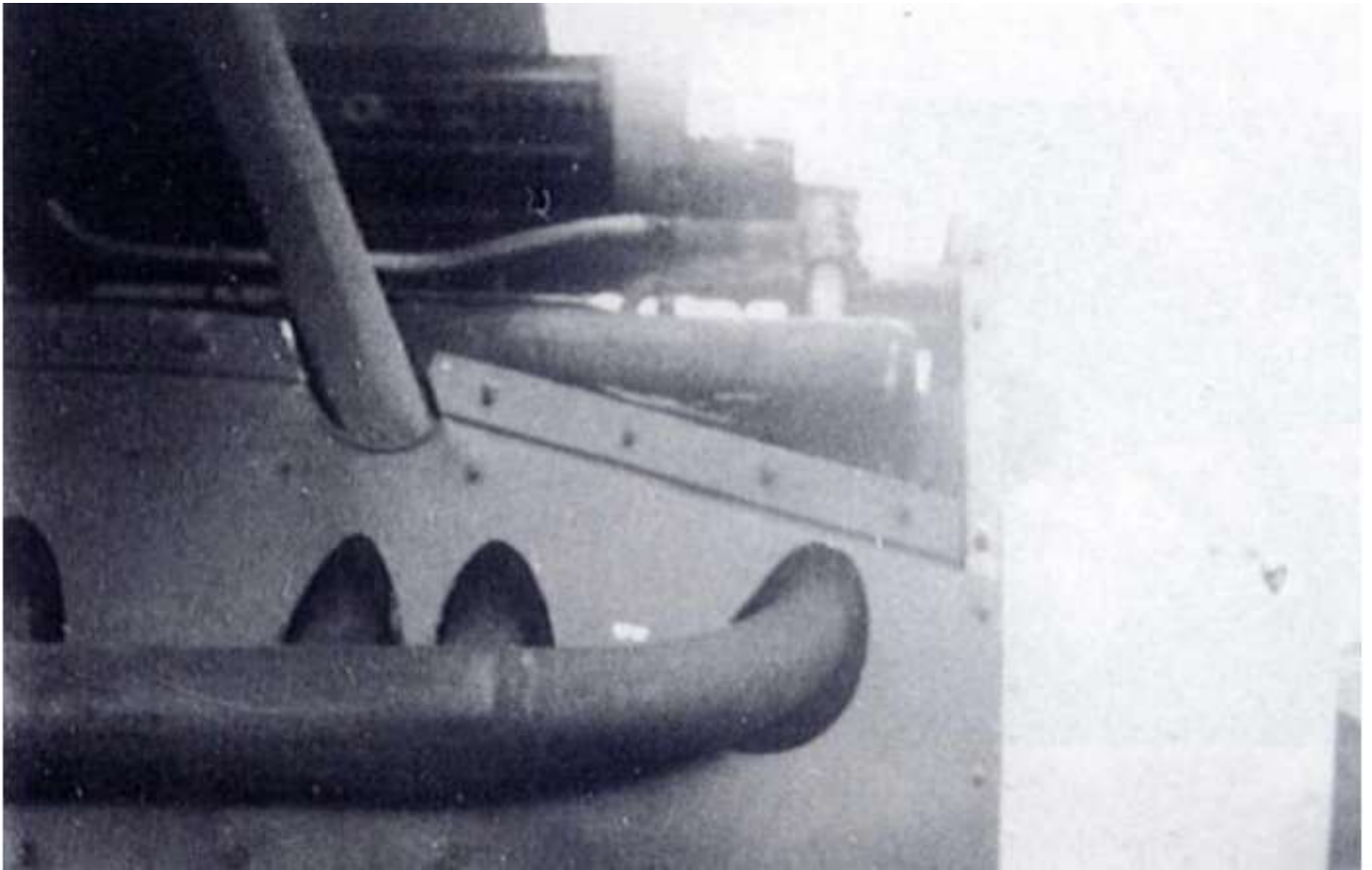

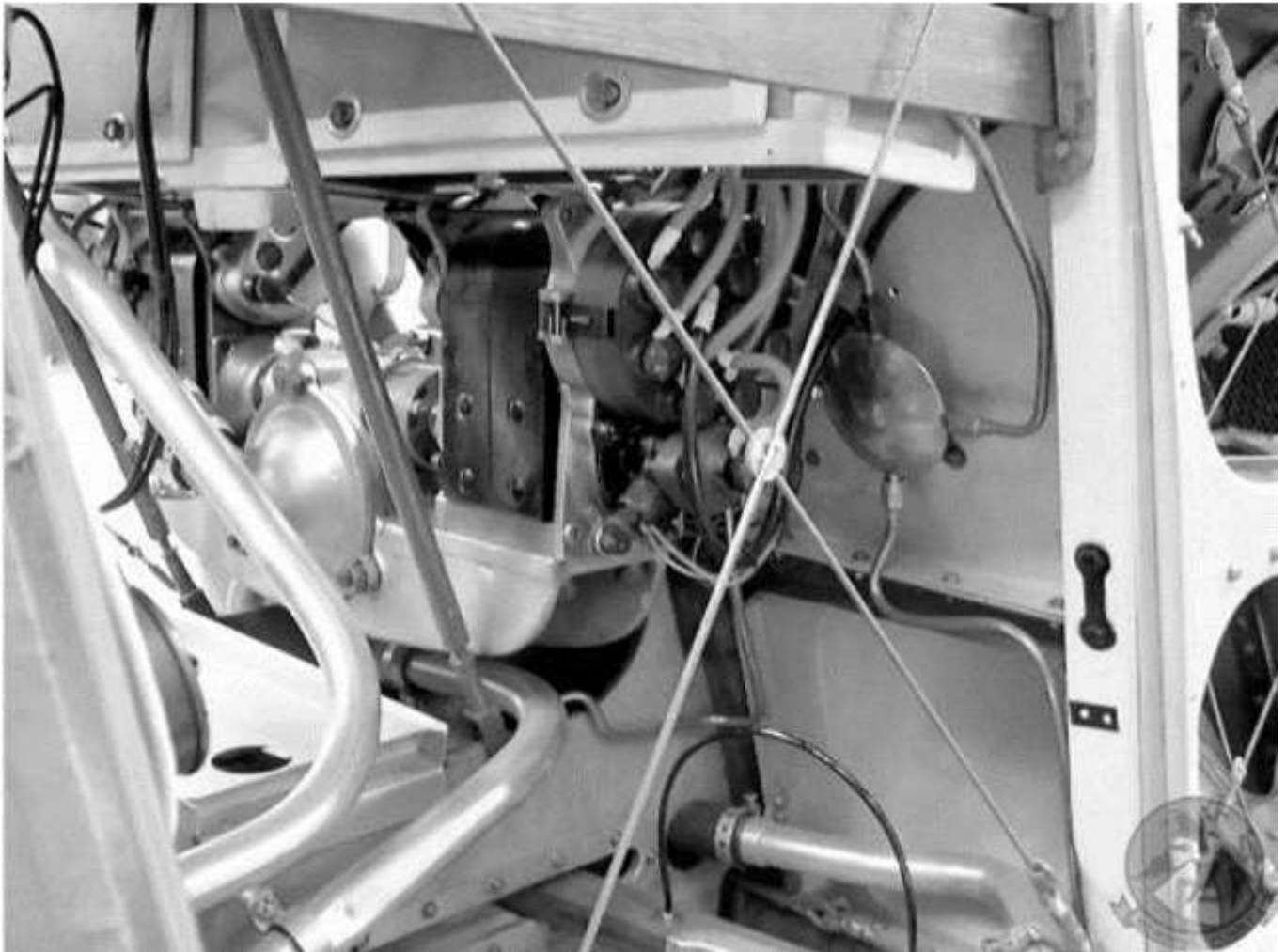

The following photo show the engine bay construction.

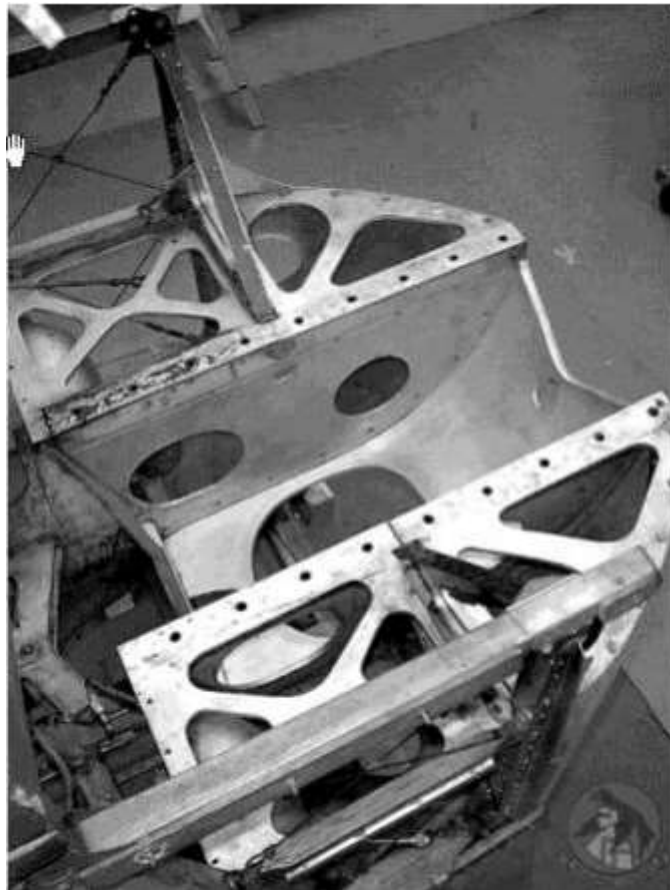

The kit does not come supplied with an engine and in fact the 'engine bay' area of the kit does not exist. Instead the forward fuselage is 'blocked off'.

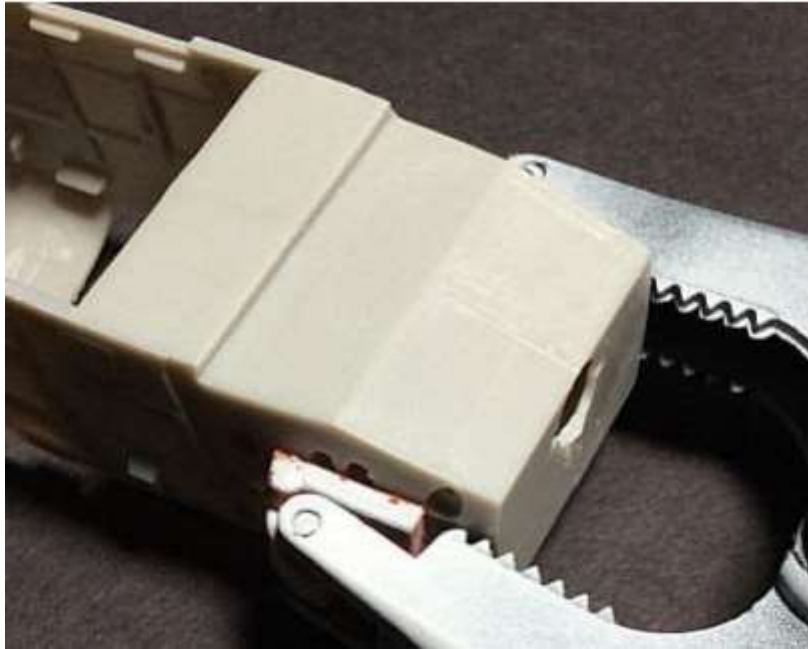

However, an engine installation can be made using the 'Wingnut Wings' sprue (132E0002) for this engine from their SE5a 'Hisso' kit or similar engines supplied by 'Roden', who have three version of this engine type, complete with engine stands and propellers. For this build I used the Wingnut Wings engine, with their online instruction sheet from the kit manual.

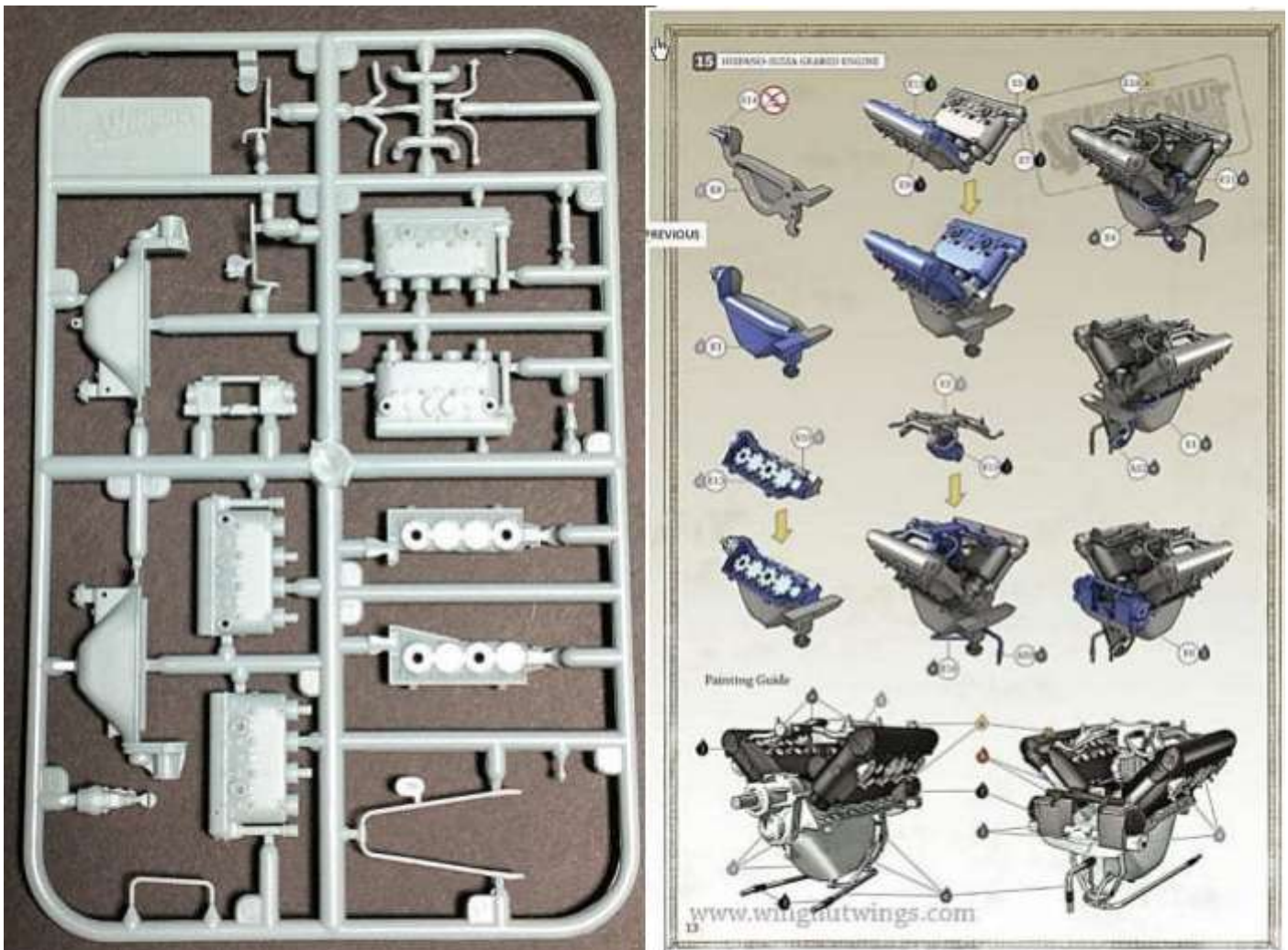

The intention is to expose the engine with the forward louvered panel removed. To install the Wingnut produced engine into the forward fuselage requires modifications to the engine. In addition, modifications to the forward fuselage are necessary. The changes are, by necessity, carried out together as the build progressed. This is done in order to be able to construct and align the various parts to ensure a good fit and to make it as authentic looking as possible, despite the fact that much of it will not be seen on the completed model.

8a. **Disregard Kit item C29** - this item represents the magneto assembly on the rear of the engine. This kit part is not required as it is included in the 'Wingnut Wings' engine, which anyway is better detailed.

8b. Cut away the areas shown in red from the kit items C21 and cockpit floor.

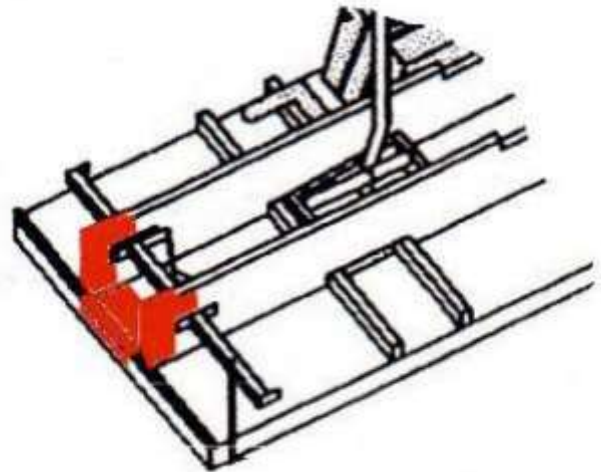

8c. Cut away the area shown in red from kit item B6. Reduce the thickness of the panel along the side edges.

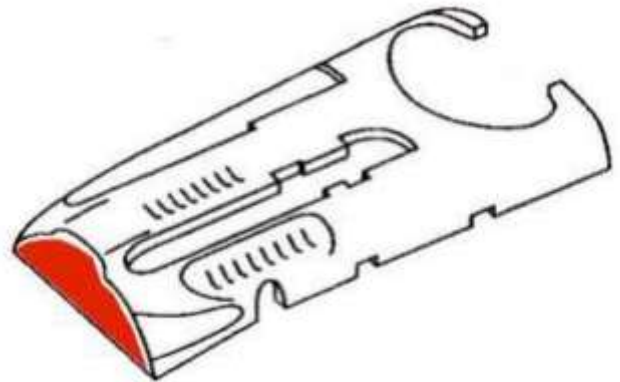

8d. Cut away the areas shown in red from the two kit fuselage halves. File or cut away the protruding 'nodules' for the exhaust ports inside the fuselage halves, to allow better clearance for the engine. Reduce the thickness of the fuselage sides and file or sand away the 'lip' at the front of the remaining flat 'cross piece'.

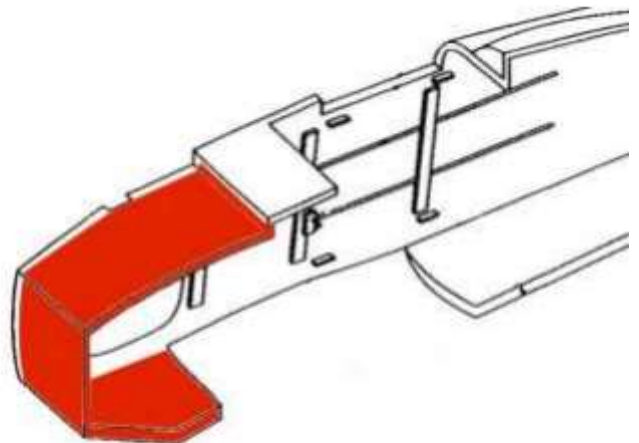

- 8e. Assemble the kit cockpit items C16, 21, 23 and 25.
- 8f. Dry fit the two fuselage halves together and hold (at the rear only) with elastic bands.
- 8g. Insert the assembled cockpit floor into the forward fuselage and locate in position. Hold the forward fuselage together with masking tape.
- 8h. Apply cement along the cockpit floor and left fuselage joint and leave to cure. Cement the left side, not the right side, as that side needs access in order to paint the oil tank next to the pilot's seat.

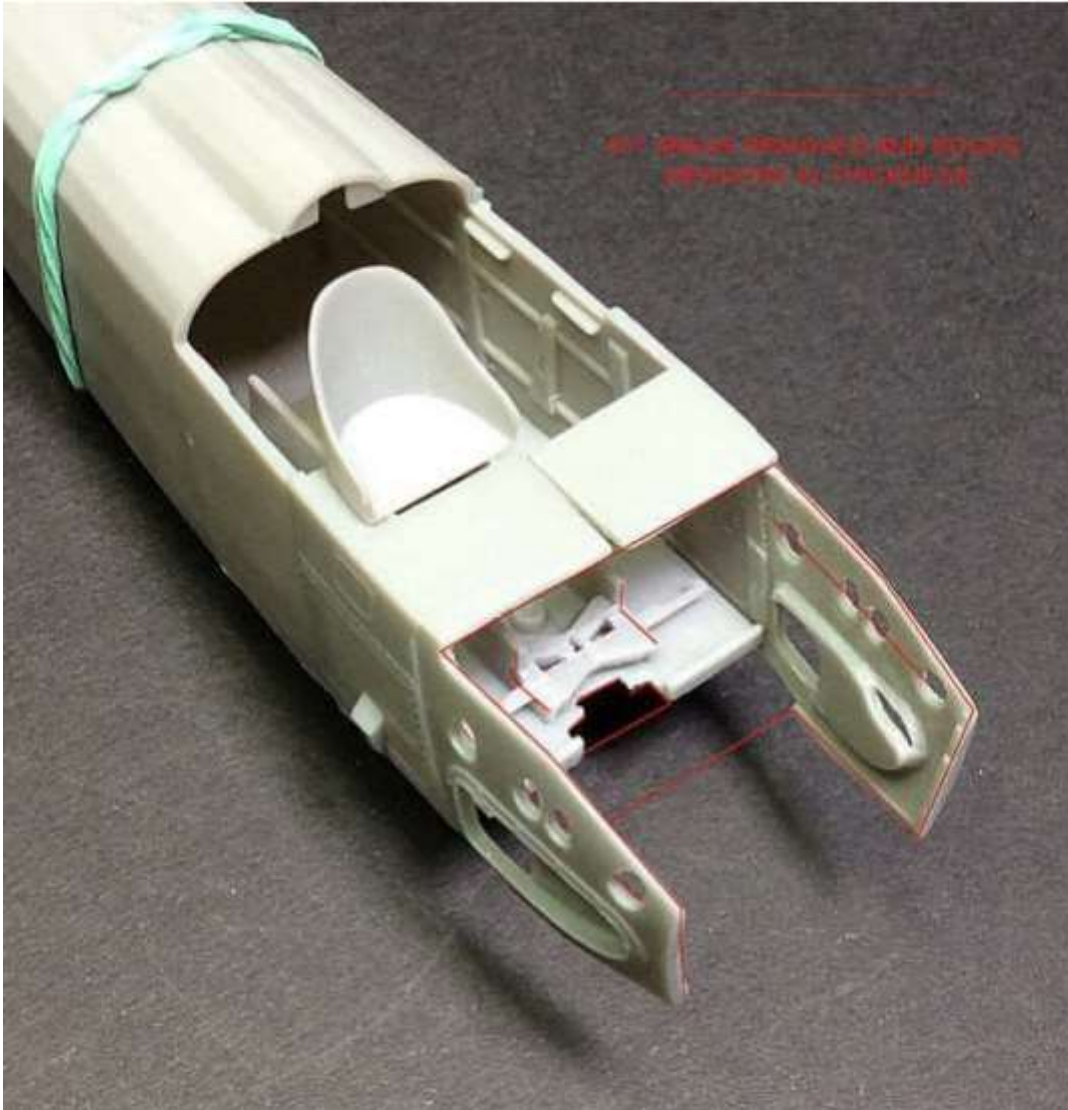

- 8i. From the Wingnut Wings Engine sprue (132E0002) assemble the engine sump (E3 and E8) with the cylinder base (E10 and E13).

Cut away the ring lug on the bottom of the sump and the pump below the rear of the engine (neither are required).

Cut away the outer sides of the magneto assembly support at the rear of the engine, leaving just a central section the width of the engine sump (to allow easier engine fitting later in this build).

Cut away the two square lugs under each side of the engine sump flange (not required).

- 8j. Assemble the two cylinder banks (E9 and E12) and (E5 and E7).
- 8k. Assemble the manifold (E2 and E15).
- 8l. Ready the magneto assembly (E6). File or sand away the underside of both magnetos so that when E6 is located onto the support at the rear of the engine, the undersides are level with the engine sump flange (to allow the engine assembly to sit fully on the engine bearers).
- 8m. Assemble these engine parts together but not with cement. Use a temporary fixative such as 'BlueTack' and masking tape. This is to allow the engine assembly to be used as a guide for constructing the forward fuselage engine bay area.
- 8n. Reduce the thickness of the magneto's support beam (Wingnut Wings item E6). Also file or sand away the rear edge of the engine sump.

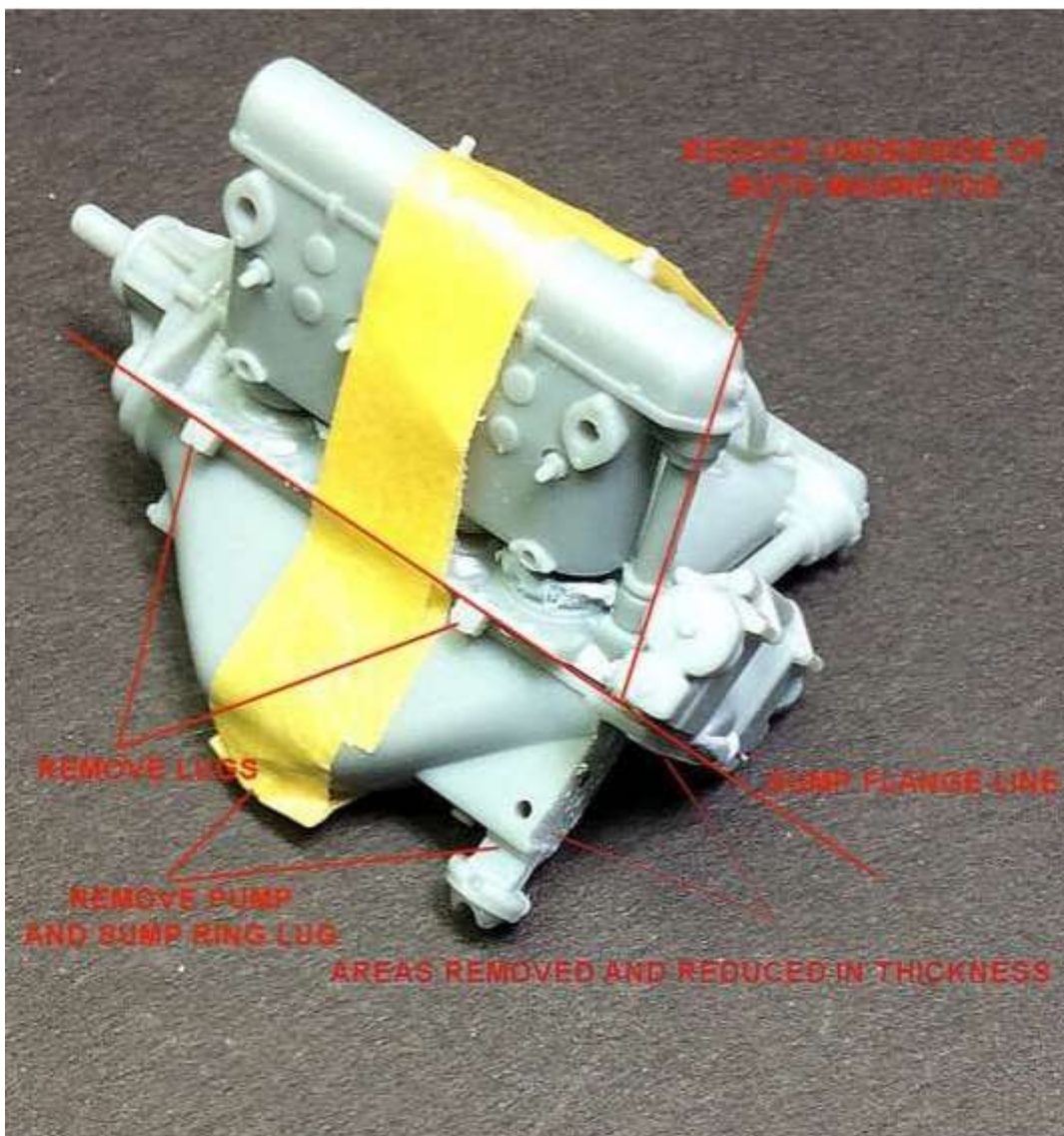

- 8o. Trial dry fit the engine into the forward fuselage, making sure the engine magneto support beam rests on the cockpit floor beam (kit items C21). Keep test fitting and filing or sanding the modified areas until the engine 'sits' correctly and the exhaust ports align with the exhaust apertures in the fuselage sides.

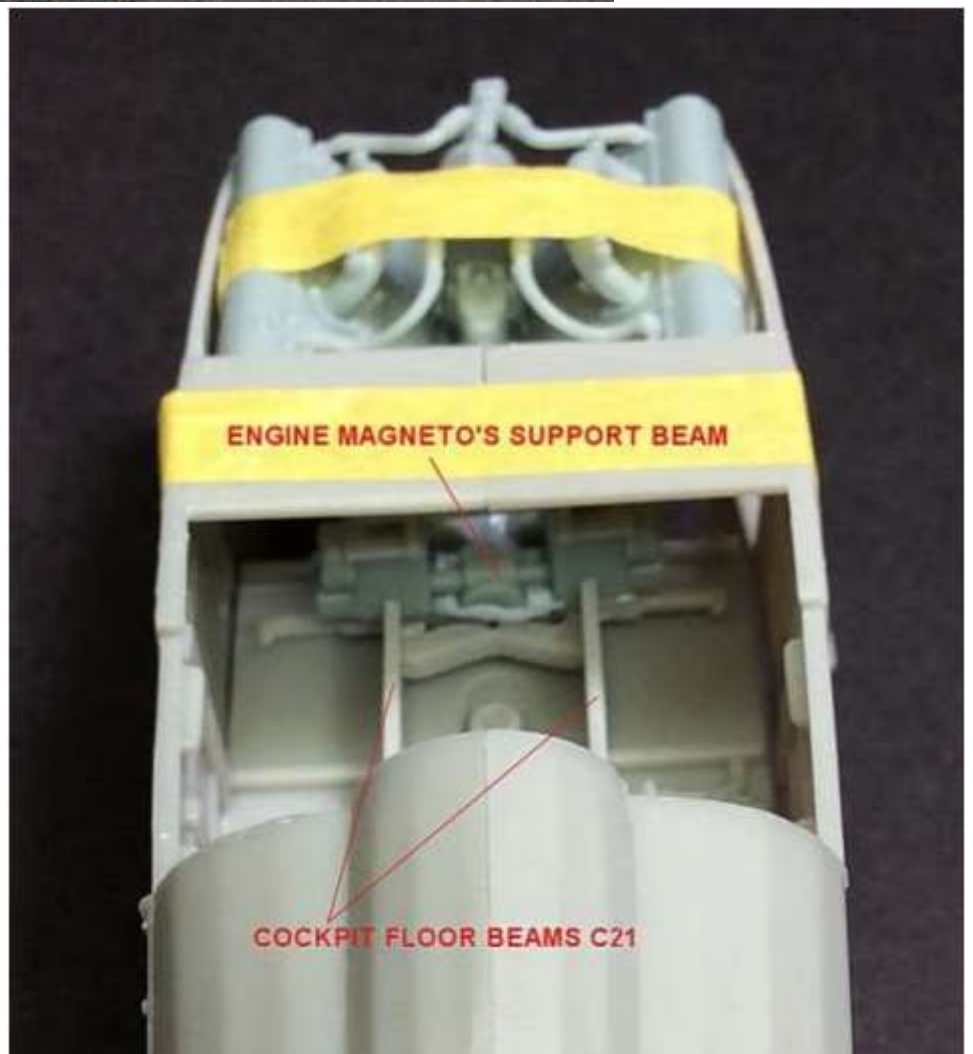
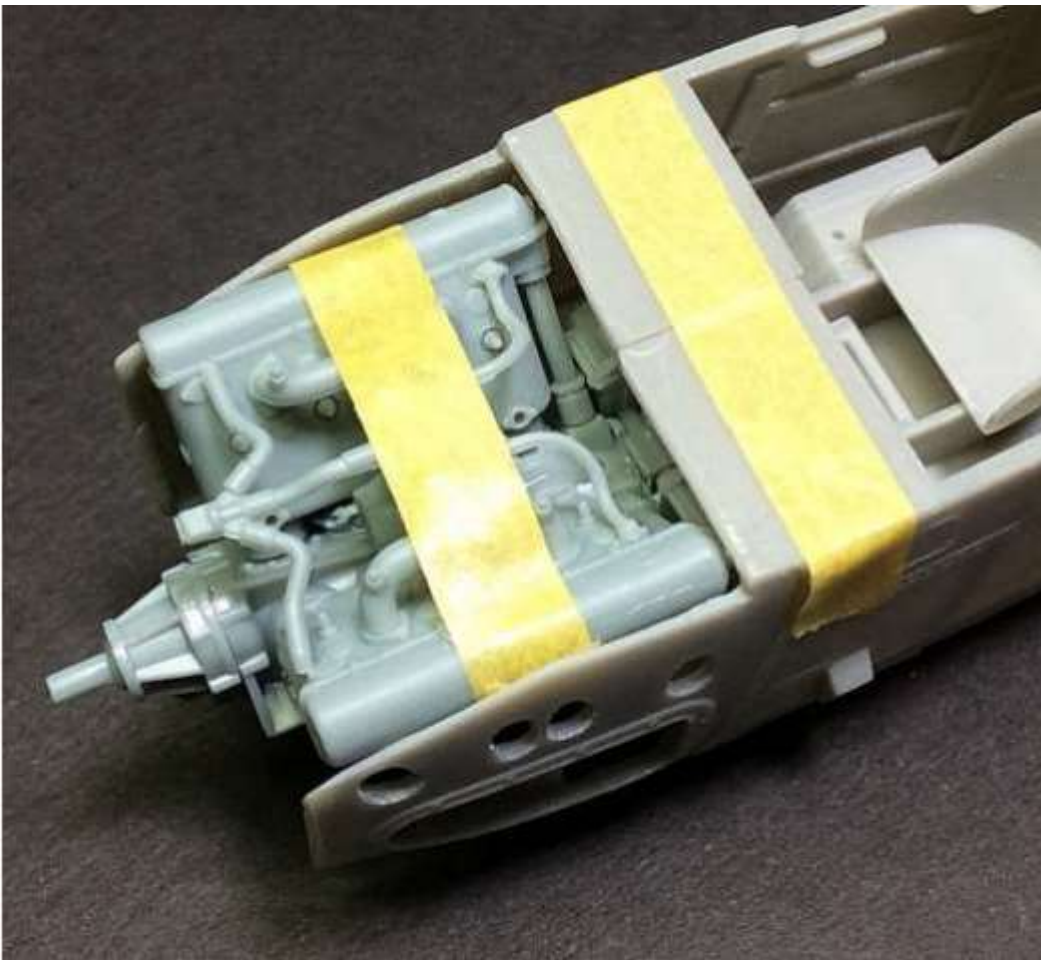

- 8p. The kits louvered top decking panel is molded in one piece, but as the intention is to have the engine exposed, this panel needs to be cut to show the rear fixed panel in position and the forward louvered panel removed.

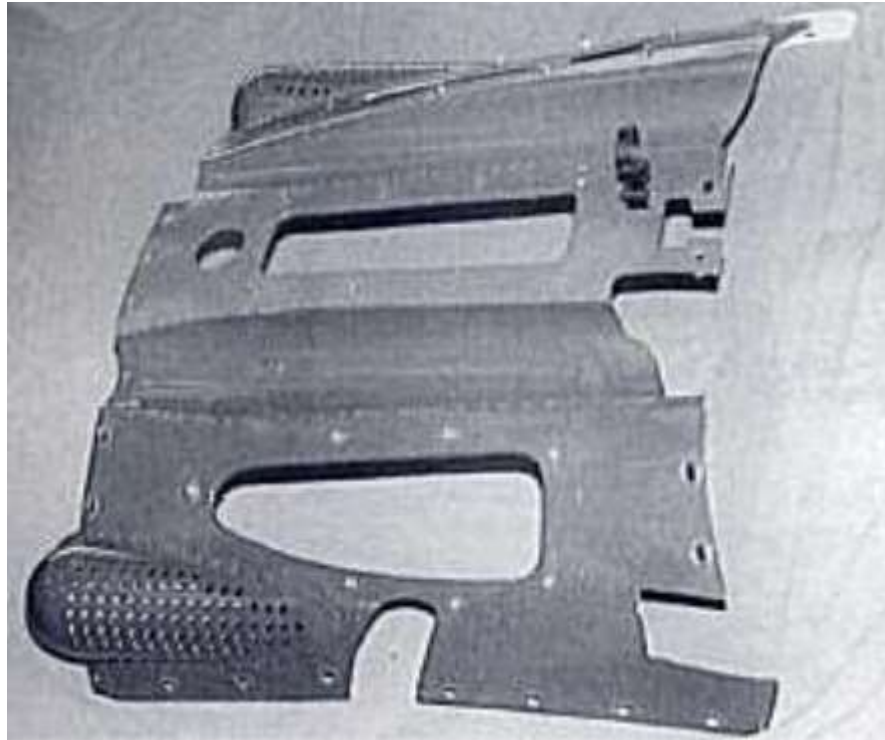

- 8q. Cut the panel across from each side and across the centre (as above actual panel). On both of the now separate panels, thin all panel edges to recreate a 'scale' thickness. Drill out the radiator filler cap in the forward panel, as this will be modelled on the exposed engine.



- 8r. Position the top decking rear panel over the cockpit and the engine into the 'engine bay' in the forward fuselage. Mark then cut away the area shown in red (in the photo below). This will be the position for the cockpit forward bulkhead.

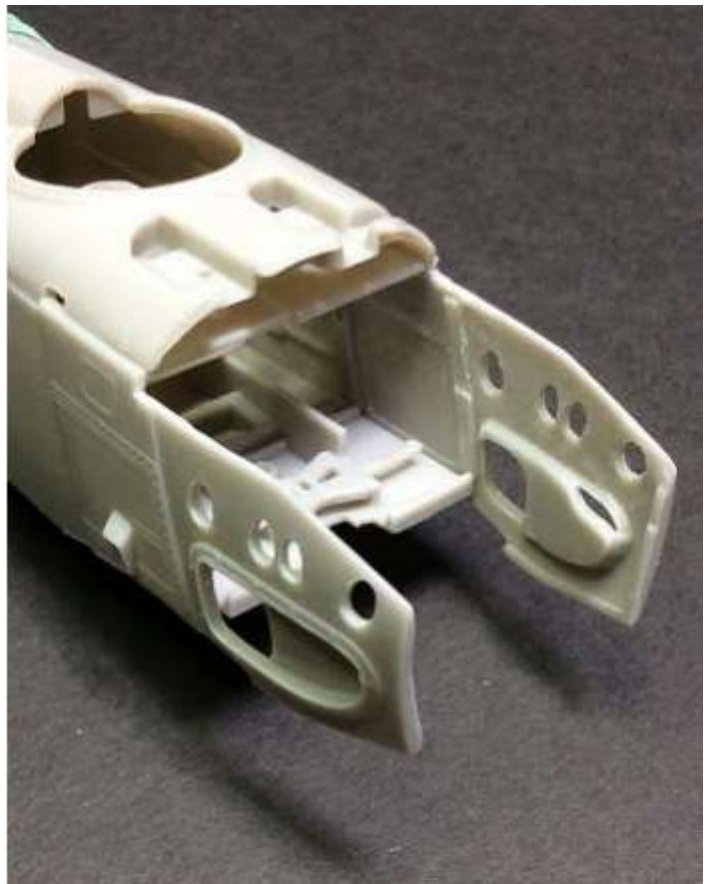

- 8s. Mark then cut away the areas shown in red (in the photo below) on the bottom wing and bottom louvered panel, to give clearance for the sump of the installed engine.



- 8t. The engine reduction gear housing on the Spad engine was encased inside a metal shroud, which was on both sides of the radiator. On the kit supplied radiator, this shroud is modelled on the front face of the radiator, but not on the rear (inner) face. Instead there is a pre-molded lug, which is for supporting and locking the propeller shaft to the radiator. In addition, the 'Wingnut Wings' engine has a pre-molded reduction gear housing on the front of the engine.



To replicate the propeller reduction gear installation, between the engine and the rear face of the radiator, requires modification to both parts.

Cut away the propeller lug from the rear face of the radiator.

With the engine, lower wing and bottom panel temporarily dry fitted (masking tape), offer up the radiator to the side of the reduction gear housing and gauge where the housing needs to be cut so that it will be 1 mm away from the radiator rear face when finally fitted.

Cut away the engine reduction gear housing from the front of the engine.

Using 0.8 mm thick plastic card, cut out an oval shape to represent the reduction gear shroud on the rear face of the radiator. Use the pre-molded shroud on the radiator front as a guide, but cut out the shroud shape to be slightly larger than the engine reduction gear housing.

Secure the plastic card cut out to the face of the engine reduction gear housing, leaving a small border showing around the edge.



- 8u. The kit supplied propeller is a single part that includes the propeller shaft. Cut back the shaft so that when inserted into the radiator, it is flush with the radiator rear face. Doing this will enable the propeller to be fitted without obstructing the engine when it is installed.
- 8v. Using photo's from the restoration of Spad XIII C.1 Serial No.4377, it would seem that the cockpit was not totally sealed from the engine compartment, but had an opening at the bottom of the cockpit/engine bulkhead for the engine magneto assembly.

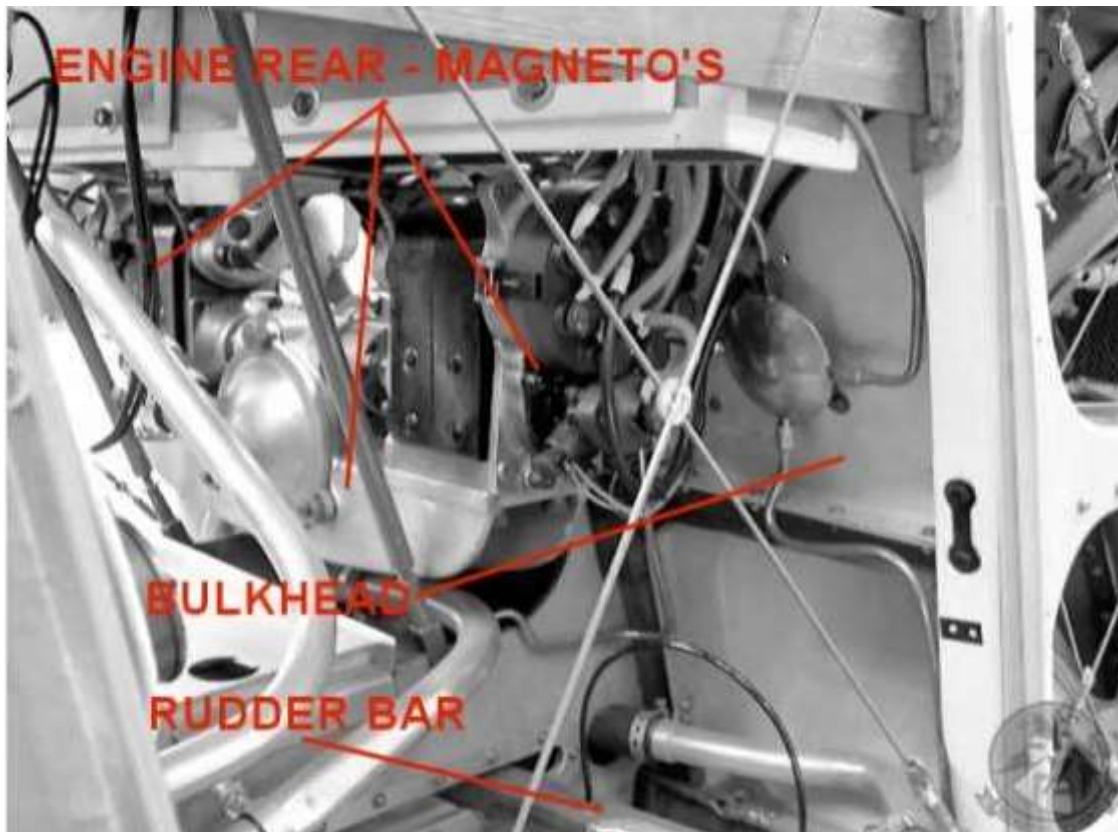

The cockpit/engine bulkhead appears to start from under the forward edge of the fixed top decking panel and drops vertically to just past the cylinder heads. On this section of the bulkhead were mounted various components, including the support brackets for the two machine guns.

The bulkhead then angles down and forwards, ending at the base of the engine support beams where the pilot's foot wells (forward from the rudder bar foot rests) were located.

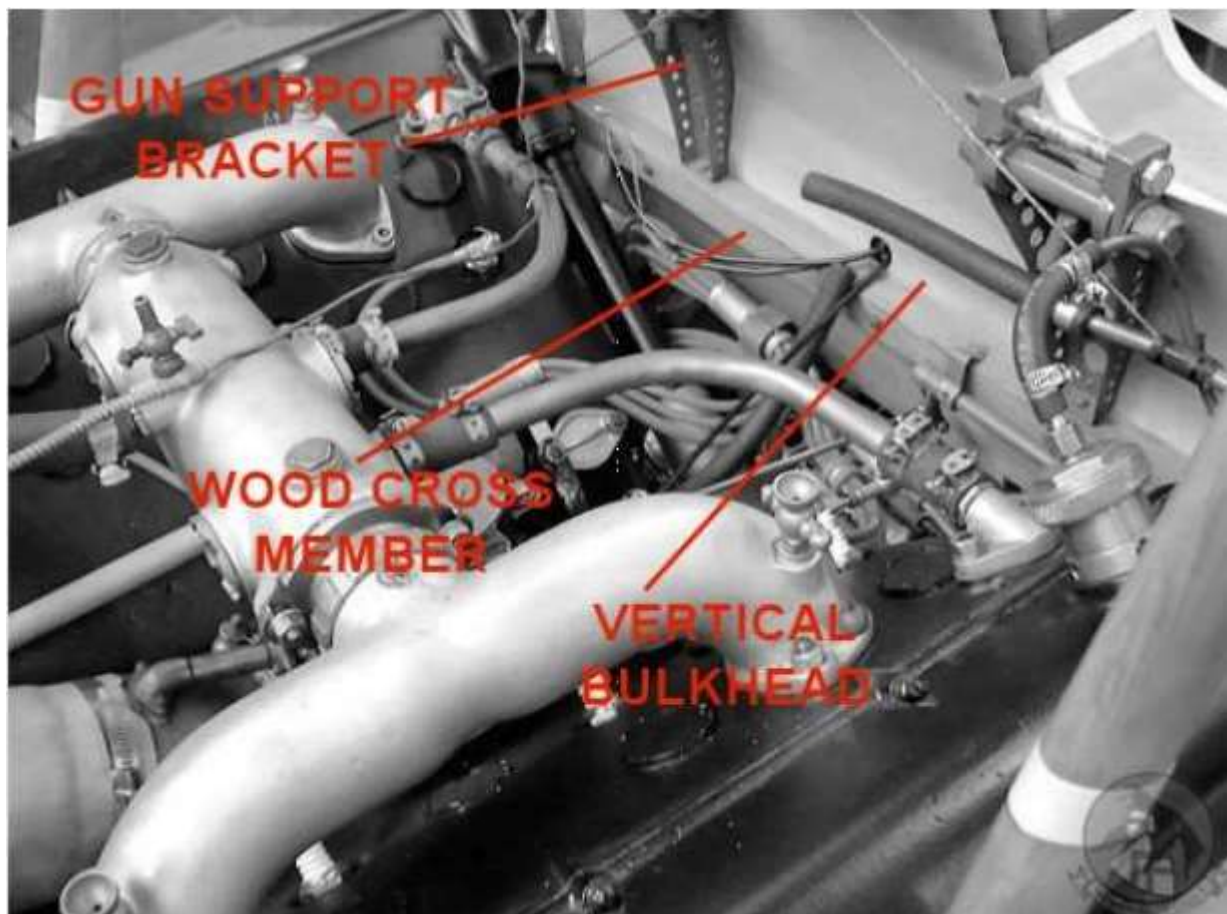
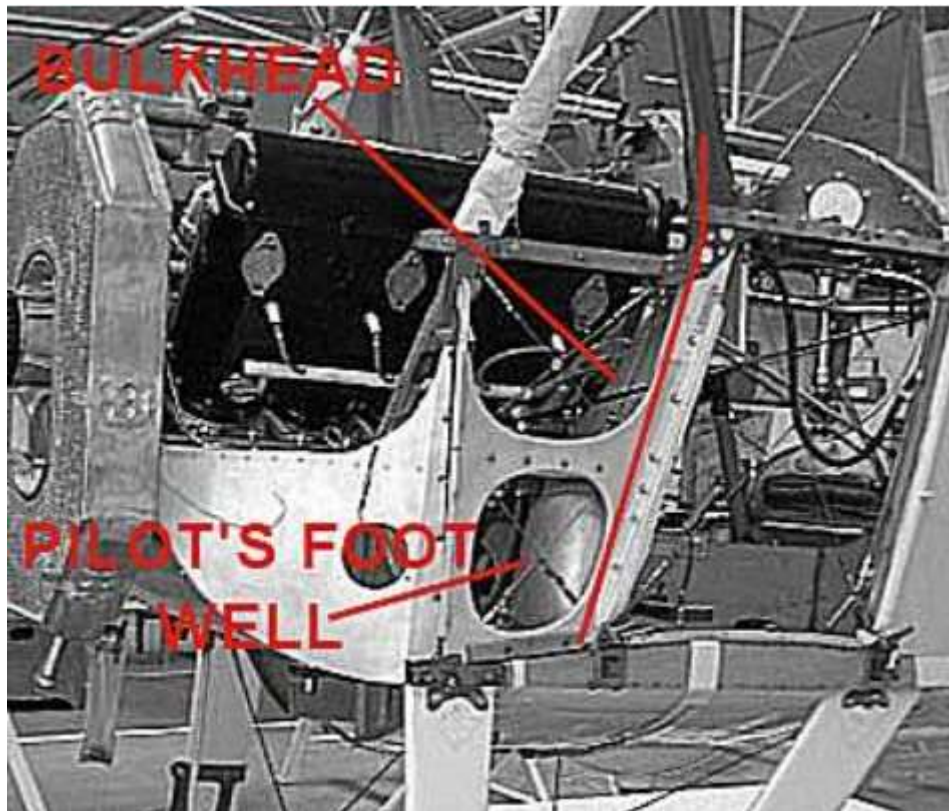

8w. To replicate the upper part of the bulkhead:

'Dry' fit the fuselage halves together (elastic bands).

Cut out a thin card template in the shape of the bulkhead.

Outline this onto a piece of 0.8 mm thick plastic card, then cut out the shape.

Thin the inner edge at the front of the decking panel at the outer corners, to enable the bulkhead to fit flush.

Trial fit and sand the edges of the bulkhead then 'tack' into position on the front of the top fuselage decking panel, using Tamiya extra Thin cement.

Cut out three strips of plastic card and 'tack' them into position under the decking panel and against bulkhead. These act as extra support for the bulkhead.

Apply 'liquid plastic' (off cuts of plastic card dissolved in Tamiya liquid cement to form a semi-thick liquid plastic) around the edges underneath the decking panel. When fully cured this forms a more rigid bond than when just using liquid cement.

Cut a length of square plastic rod and secure across the bulkhead level with the fuselage sides. This represents the wood cross member.

NOTE: The bulkhead will be fitted later in this build.



8x. To replicate the lower part of the bulkhead:

With the fuselages halves 'dry fitted' together (elastic bands), locate the top decking panel with the top bulkhead fitted.

Cut out a thin card template in the shape of the lower bulkhead.

Outline this onto a piece of 0.8 mm thick plastic card, then cut out the shape.

Trial fit and sand the edges of the lower bulkhead so that the top edge rest against the upper bulkhead and under the 'wood cross member'.

Remove and carefully bend the two 'legs' of the lower bulkhead to form backward facing curves, which will represent the pilot's foot wells in the bulkhead. Use your fingers to bend the 'legs' gradually, otherwise the plastic card will crack or snap.

Trial fit the lower bulkhead.

Finally apply a light coat of Tamiya Extra Thin liquid cement across both sides of the bent 'legs', to soften the plastic card and weld any minor cracks in the surface.

NOTE: The bulkhead will be fitted later in this build.

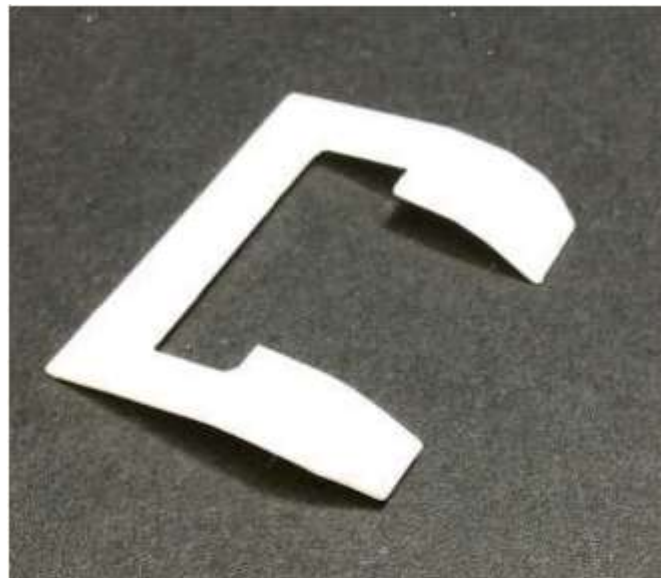

- 8y. The engine in the Spad aircraft was supported on two engine bearers, which ran forwards on the bottom of the engine bay in the forward fuselage. These were partially visible through the mesh of the access panels, when these type of access panels were fitted in place of the solid louvered access panels. The visible area of the bearers had a large lightening hole, which will be shown for this model.



'Dry' fit the fuselages halves together (elastic bands), including the top decking panel (with upper bulkhead), lower bulkhead and bottom louvered panel.

Use a piece of card to cut out two templates for the bearers. These templates need to reach from the front 'lip' of the bottom louvered panel to the over the front of the cockpit floor. Cut out notches to clear the lip of the bottom louvered panel and the lip on the forward edge of the cockpit floor. Also cut a double notch to clear the two lips at the rear of the bottom louvered panel and lower wing joint.

Test fit the engine onto the two template bearers and adjust as required until the engine sit level on the bearers with the rear support for the engine magnetos resting on the rudder bar cross member.

Use the card templates to cut out the bearers from 0.8 mm thick plastic card.

Test fit the engine onto the two template bearers and adjust as required until the engine sits correctly.

Drill and cut out the lightening hole at the rear of each bearer.

Secure the bearers to the engine using 'liquid plastic' (refer to Page 46).



NOTE: All other engine and engine bay detailing will be covered later in the build (refer to Part 6 of this build log).

9. **Fuselage internal:**

Inside the fuselage on the right side and behind the pilot's seat was a rectangular 'storage' compartment in addition to cross members between the fuselage frames. The pilot's shoulder restraint straps were attached to a cross member.

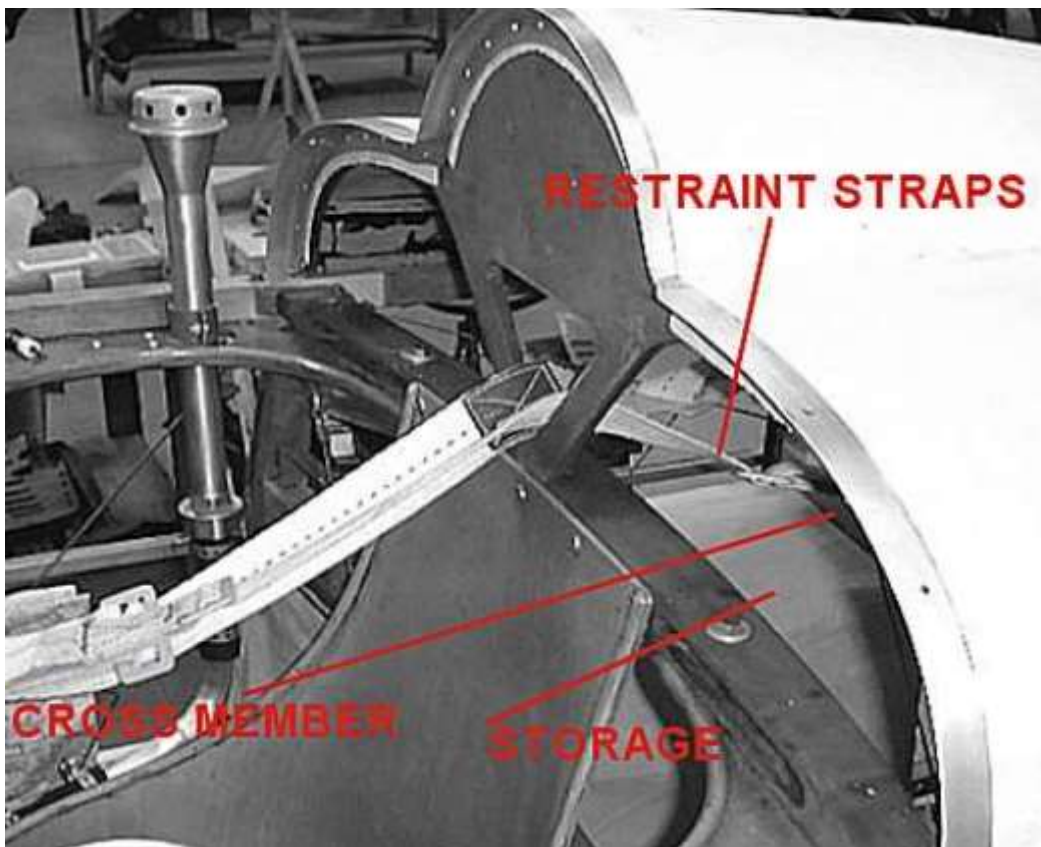
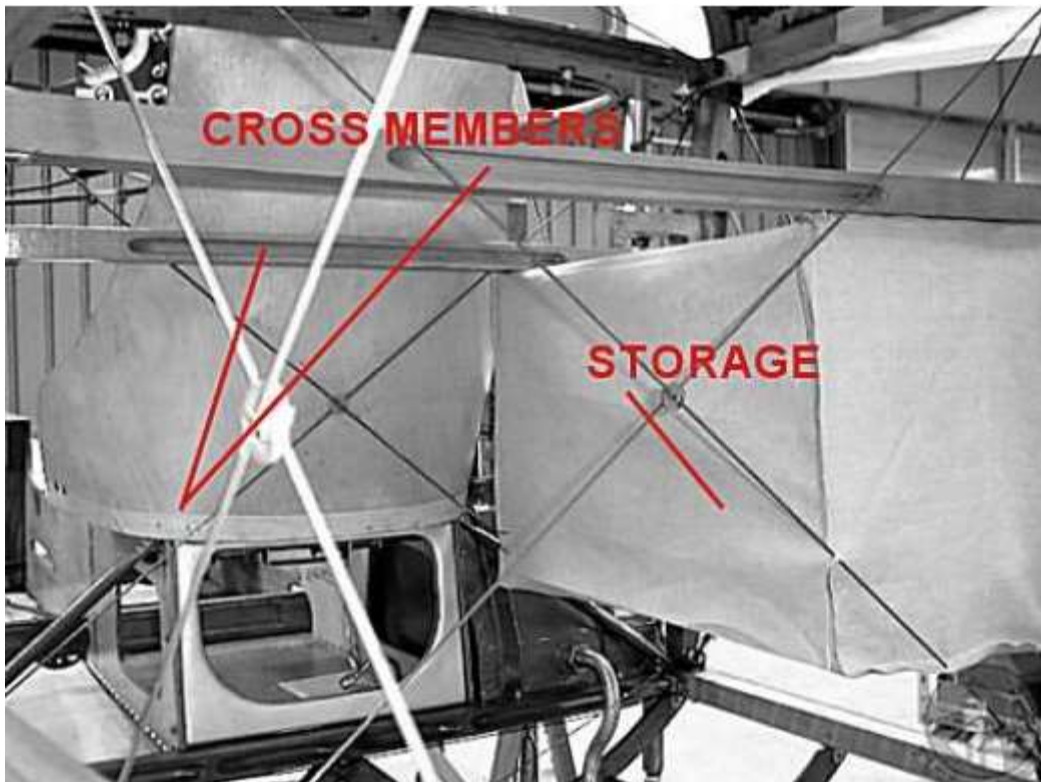

To replicate the container:

Using 0.8 mm thick plastic card, cut out the front, top and inner side of the container.

Secure the container front onto the right fuselage half, underneath the upper pre-molded horizontal rail and against the rear angled former. The bottom of the front needs to clear the locating lug for the cockpit floor by at least the thickness of the floor panel.

Secure the container top underneath the upper pre-molded horizontal rail and against the container front. The length of the top needs to be approximately 3/4 the length of the premolded horizontal rail.

Secure the container inner side to the container front and top.

To replicate the cross members:

Cut a length of 1.0 mm diameter brass rod or plastic rod to a length that, when tacked onto the forward edge of the container (with Bluetack or similar), will just touch the inside of the right fuselage when the two are joined.

Separate the fuselage halves and removed the rod and remove the 'tack' used.

Secure the rod to the forward edge of the container using thin CA adhesive.

Repeat the procedure for the rear cross member. This will be slightly shorter in length, due to the taper of the fuselage. Secure the rod in position on the rear edge of the container.

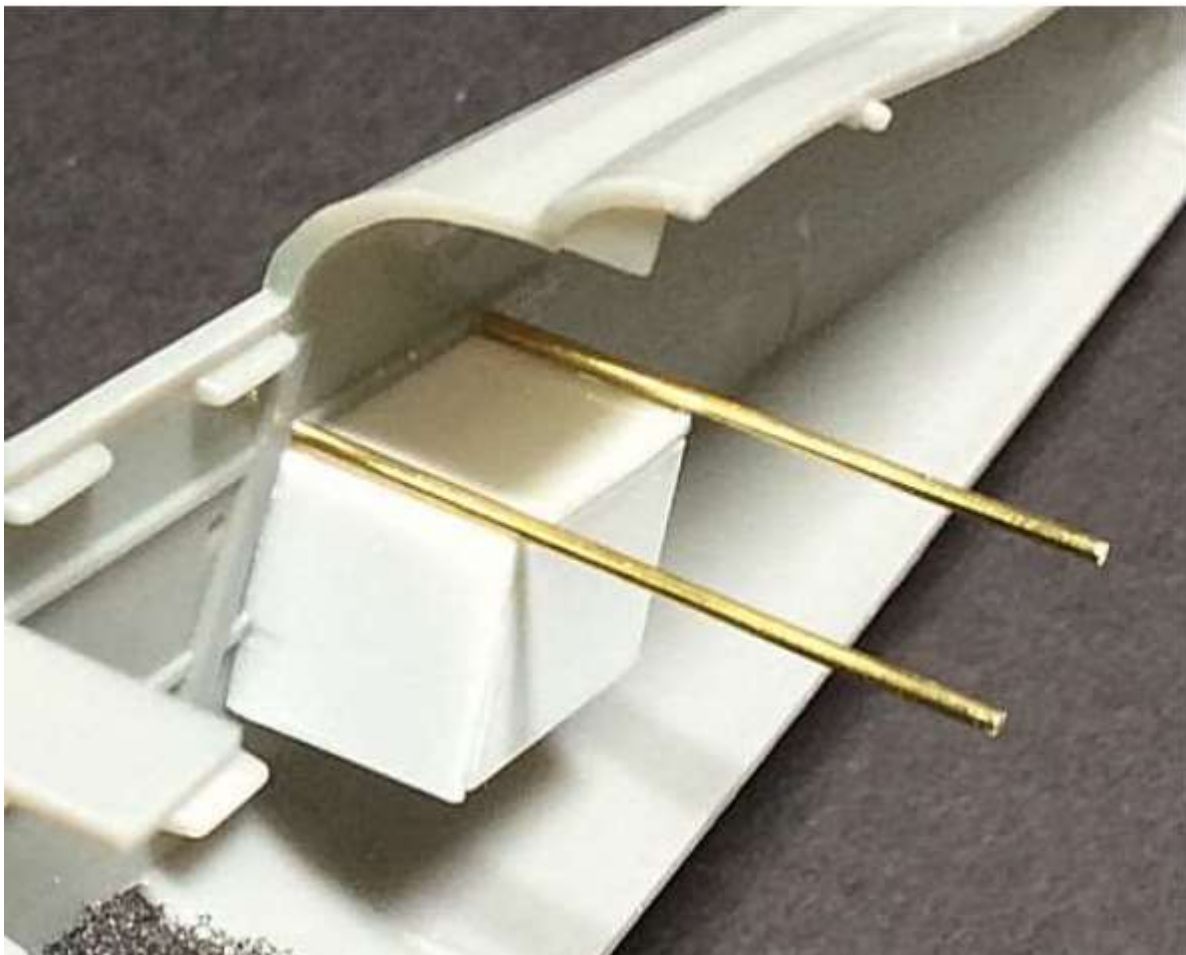

10. Access panels - mesh:

The Spad aircraft had a louvered access panel fitted at each side of the fuselage. These panels allowed hot engine air to flow out to atmosphere.

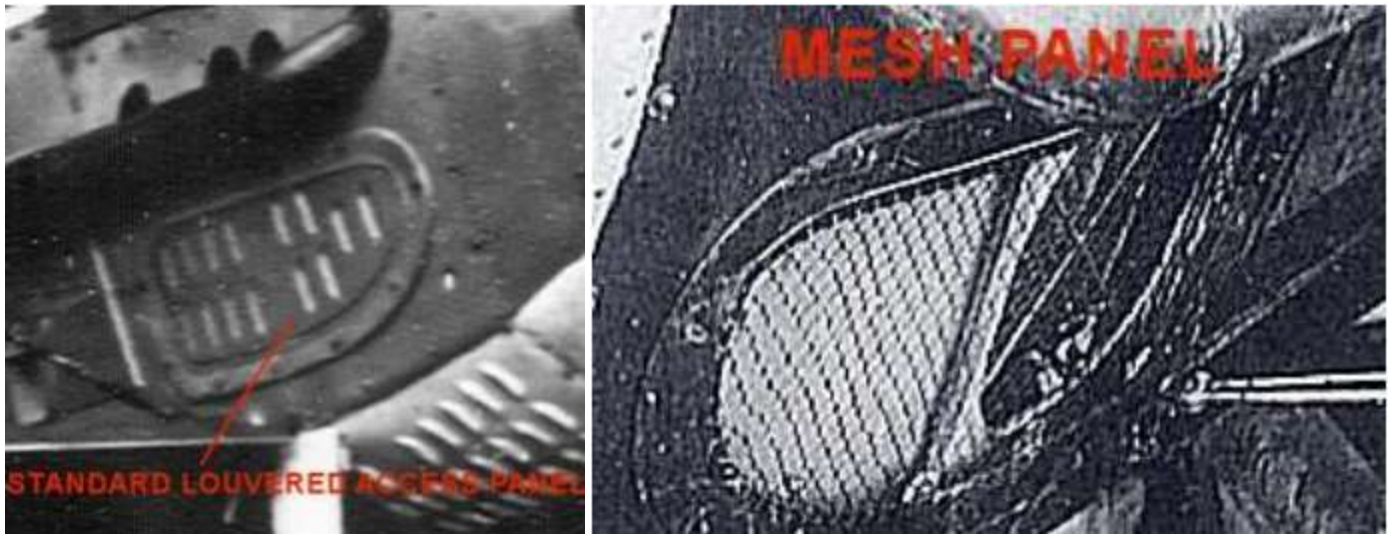

However many Spad fighters had these panels replaced with wire mesh versions, which allowed for better engine cooling.



The kit supplied access panels are molded a single, louvered panels. However many of the Spad Xiii aircraft had the louvered panels replaced with wire mesh, to allow better cooling of the engine bay area.



Wire meshed access panels: To represent the wire mesh in the two engine access panels, I used the 'crew guard' mesh from the HGW Photo-Etch Detail set (Gotha C.IV 132090 interior). The wire mesh guards supplied in this set are of the approximate scale and pattern and the set is, as far as I'm aware, one of a few available with 1:32 scale mesh.

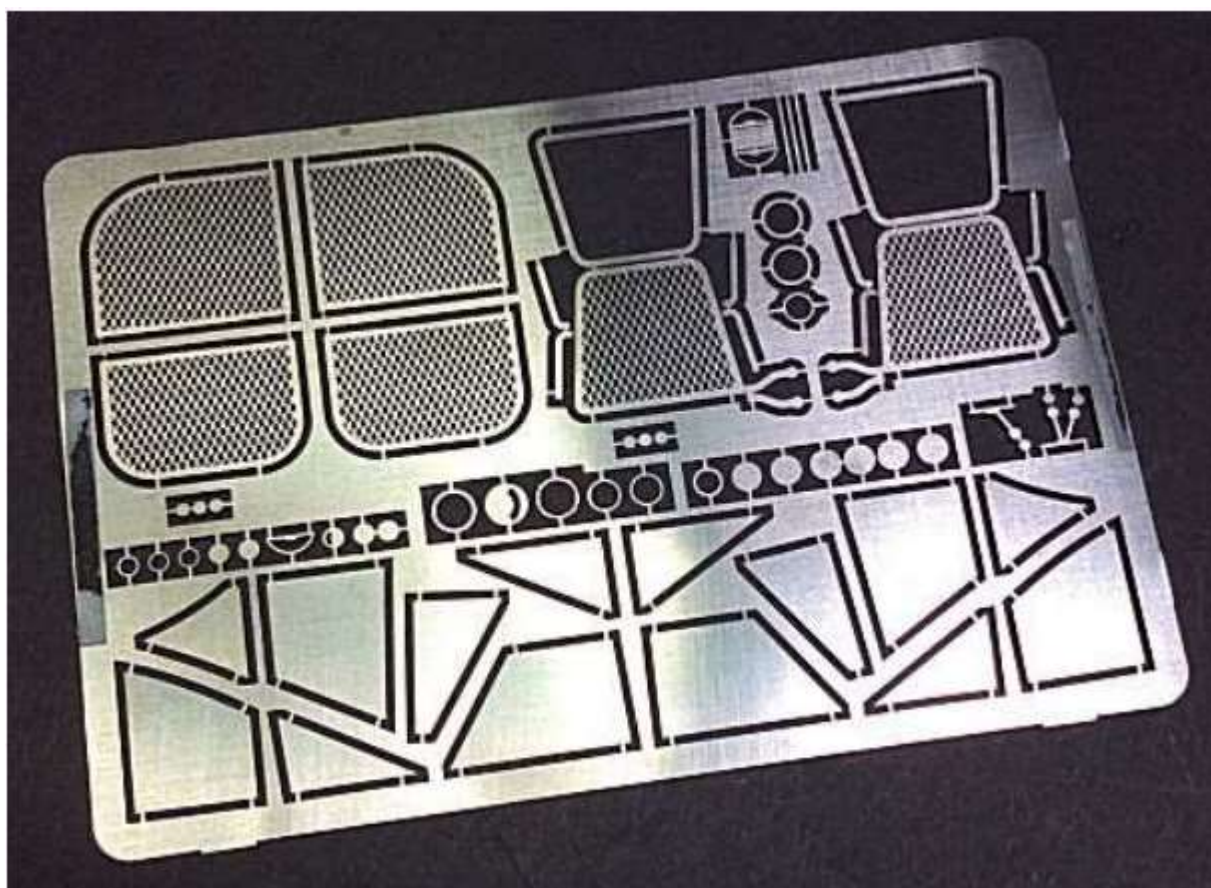

Place a strip of masking tape across the chosen photo-etch wire mesh.

Using the kit supplied louvered panels, trace their outline onto the masking tape.

Using a sharp pair of scissors, cut out the panel shapes from the photo-etch mesh.

Test fit the mesh 'panels' into their respective apertures in the fuselage sides and carefully trim, as required, to ensure a good fit.

NOTE: The two mesh 'panels' will be fitted later in this model build.



11. Gun installations:

The Spad XIII aircraft carried two synchronised Vickers machine guns, which fired a 0.303 inch (7.7mm) round. The American 'Colt' company were licensed in 1916 to produce Vickers guns for Russia, but this was cancelled due to the revolution in 1917. It was decided that 'Colt' should convert these guns to fire the French 11 mm Gras incendiary round. These guns became known as the Vickers 'Balloon Gun' and were fitted to some aircraft for attacking German observation balloons. Frank Luke Jnr flew the Spad XIII with the 27th Aero Squadron, who were known to have aircraft fitted with the 'Balloon Gun' and he was famous for destroying in total 14 German observation balloons, I decided to fit this model with one standard Vickers 0.303 and one 'Balloon Gun'.

The machine guns were fitted into recesses in the cockpit decking panel, just forward from the cockpit opening. Unlike most other fighter types of that period, the guns were set low in the panel such that only the top of the breech block was visible. As the gun cocking handle was normally located on the right side of the breech, the decking panel had recesses adjacent to the cocking handles to give suitable clearance. The windscreen for the pilot was fixed in position in front of the pilot, but behind the guns breech blocks. Each gun had an chute fitted to the left of the breech block for diverting the ejected rounds.

To date, the only photograph I've seen of installed guns in Spad XIII aircraft that show clearly the exposed cocking handles is shown below. I assume that the pilot needed to reach up and over the windscreen to manually cock each machine gun. Given this is correct, I chose to fit the 'Balloon Buster' gun on the right (starboard) side, as it had a different design of cocking handle to the standard 0.303 gun.

To replicate the installed machine guns requires modification of the cockpit decking panel, both machine guns and creation of mounting brackets for the upper engine bulkhead.

I chose to use the following machine guns to replace the basic kit supplied versions:

Left (port) side - 'Gaspach' -1:32 scale Vickers Machine Gun (Hyland Type B) (13-32046).

Right (Starboard) side - 'Gaspach' -1:32 scale Vickers 11 mm Balloon Machine Gun (13-32042).

NOTE: Take care when handling the 'Gaspach' guns. They are made from resin and are brittle and easily damaged or broken. Removed material is shown in red on the relevant photos.

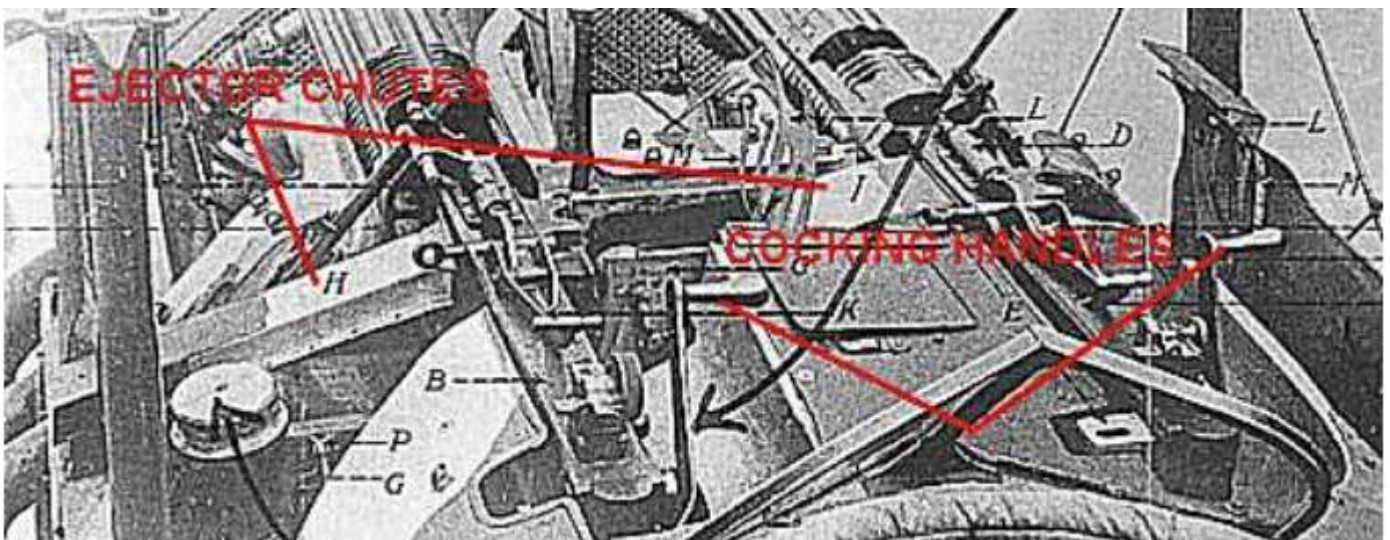

- 11a. **Vickers Machine Gun (Hyland Type B)** - Carefully file or sand away the bottom of the breech block until approximately 1 mm is left between the bottom of the breech block and the bottom of the ammunition belt feed aperture on the right side of the gun (for clearance in the panel recess). Do not remove the two mounting lugs at the front of the breech block, as these will be needed.
- 11b. Using a razor saw, carefully cut away the gun cocking handle assembly (this needs to be repositioned on the gun breech block so as to clear the pilot's wind screen).
- 11c. File or sand away the gas tube cover that is located along the left side of the breech block until it is approximately 0.5 mm thick (for clearance in the panel recess).
- 11d. File or sand away the rear of the breech block (for clearance in the panel recess).
- 11e. Using thin CA adhesive, secure the cocking handle assembly to the breech block (refer to the photograph below for positioning).



- 11f. In the left gun recess of cockpit decking panel, file or sand away:
 - The outer wall of the gun recess.
 - The ammunition feed on the inner wall of the gun recess (forward edge).
 - The bottom of the gun recess where the gun breech block will be located.
 - The rear inner corner of the gun recess (clearance for the gun cocking handle).Cut away a clearance slot in the inboard bottom of the gun trough (for clearance of the gun cocking handle).

As you do the above, keep test fitting the modified gun until it sits correctly in the gun recess with the ammunition feed aperture aligned with the panel feed and the ammunition eject aperture with the exit chute in the panel.

11g. In the right gun recess of cockpit decking panel, cut, file or sand away:

The base of the gun recess to leave approximately 3 mm of the base at the forward end.

The base of the gun recess to its outer edge.

The rear outer corner of the gun recess (clearance for the gun cocking handle).

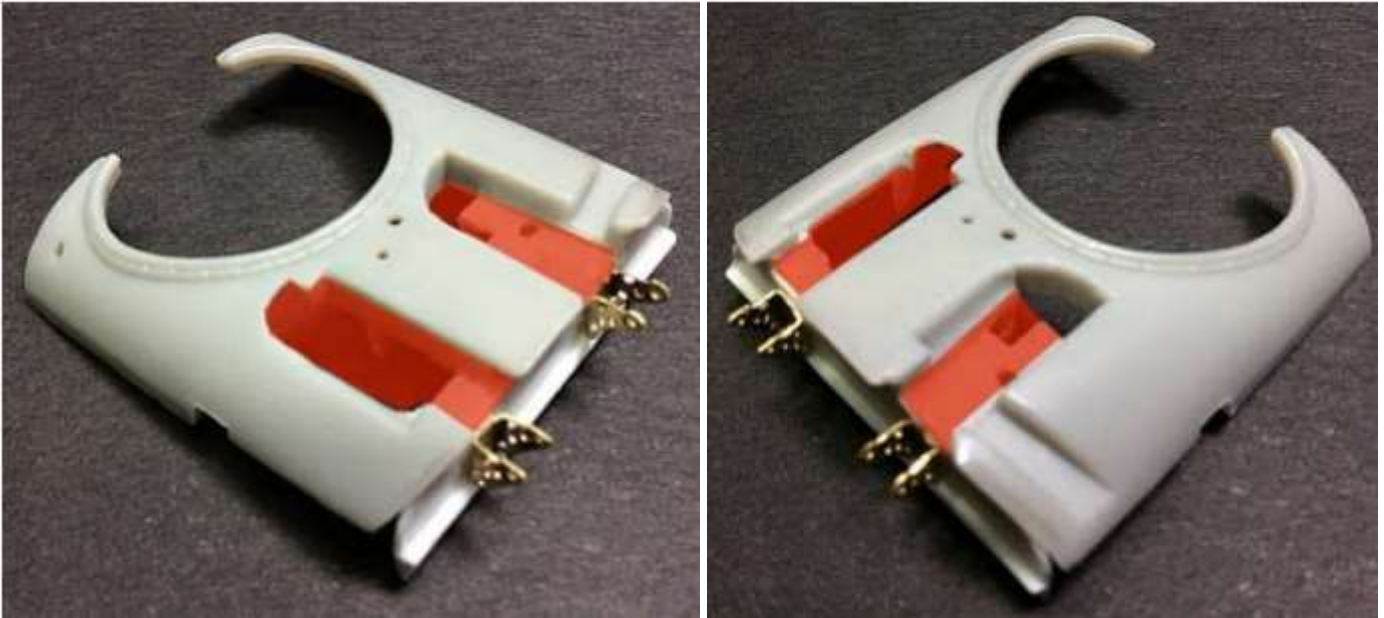

11h. **Vickers Machine Gun ('Balloon Gun')** - Carefully file or sand away a 'notch' in the bottom of the breech block, so that it will sit over the remaining base of the gun recess.

As you do the above, keep test fitting the modified gun until it sits correctly in the gun recess with the ammunition feed aperture aligned with the panel feed and the ammunition eject aperture with the exit chute in the panel. Also that there is adequate clearance for the gun cocking handle (otherwise it may break off).



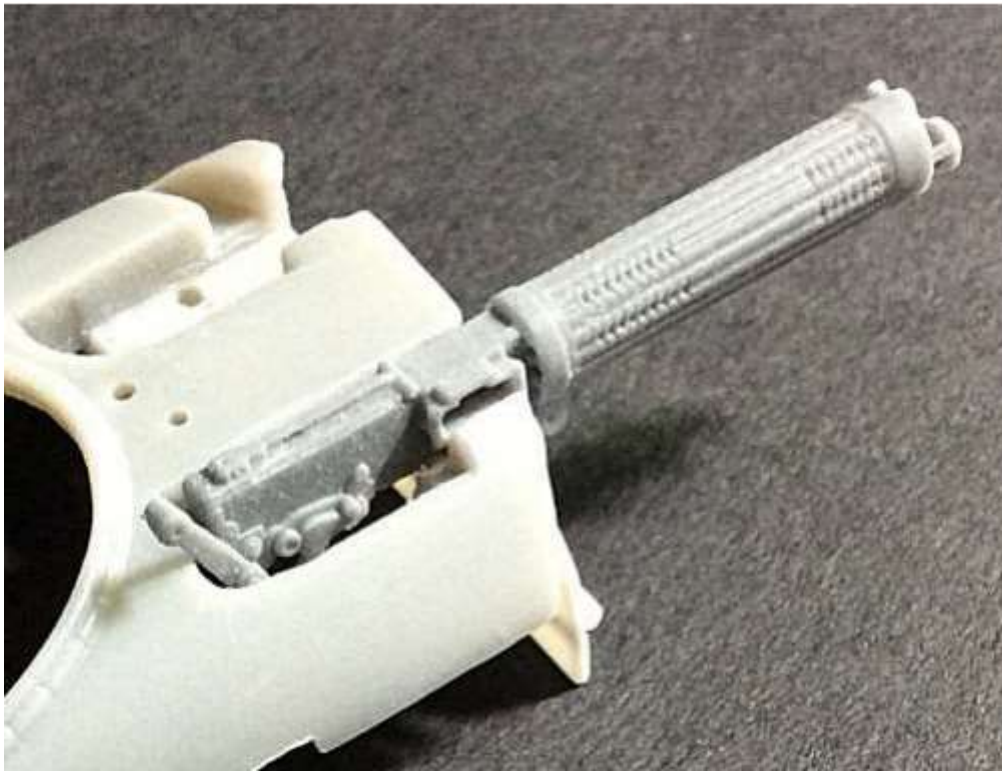

Mounting brackets:

Each gun was supported at the front of the breech block by a pair of mounting lugs, which were attached to the top of a curved support bracket with a pillar bolt. The brackets were attached to the top of the engine bulkhead. The brackets had lightening holes in the sides and back.

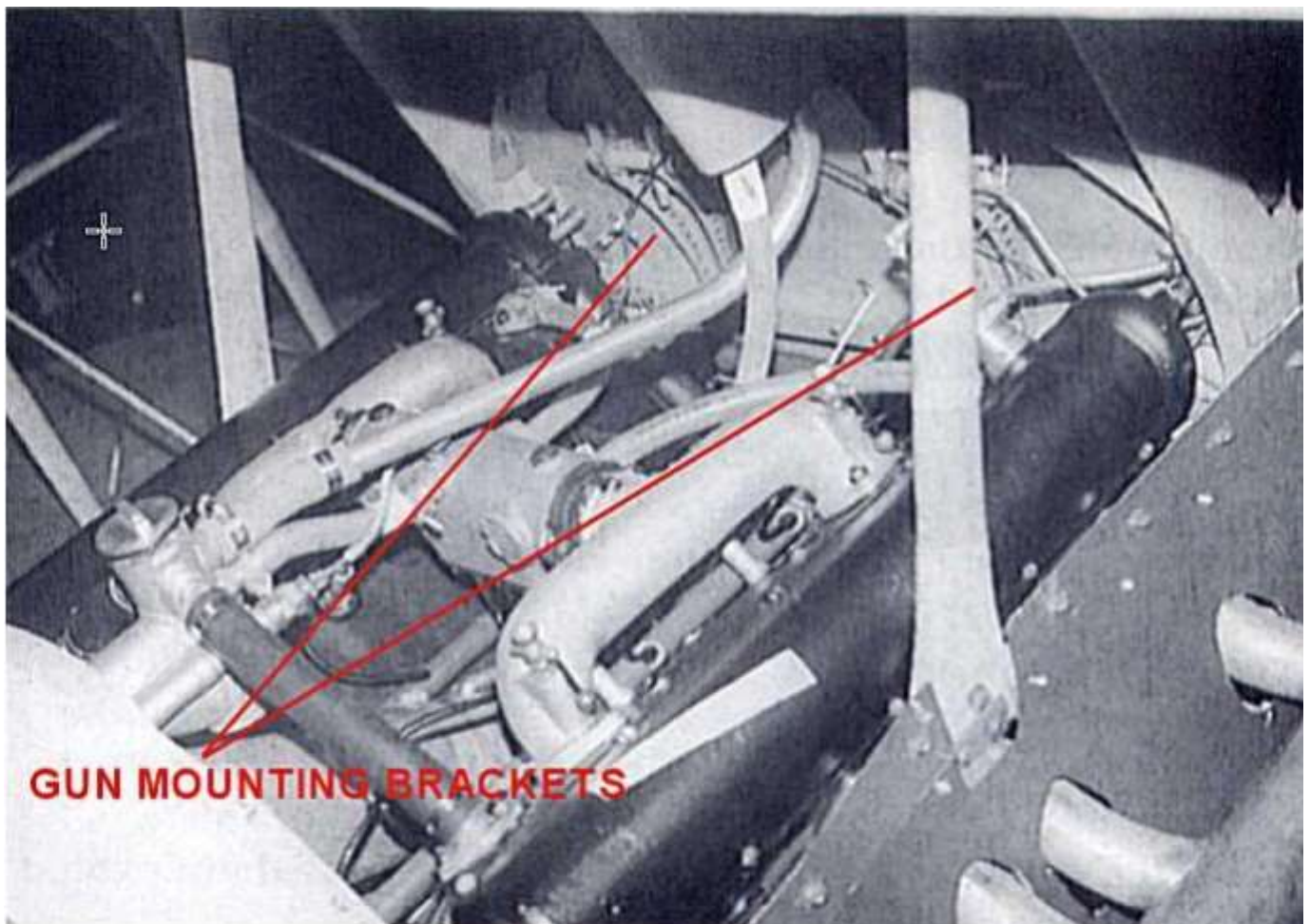



The rear support for each gun was, I believe, from a metal pillar mounted between the bottom rear of the guns breech block and the cockpit surround panel. For this build I chose to replicate only the gun support brackets located on the engine bulkhead, as the rear support pillars will not be seen in the completed cockpit.

- 11i. *Start with the standard Vickers machine gun, which will be located in the left gun trough in the rear decking panel.*

With a pencil I marked, on the face of the upper bulkhead, the centre of the left gun trough.

I temporarily held the gun in the trough (Bluetack or similar).

Using thin card I cut out and folded a template for the basic shape of the mounting bracket. This template was used to outline the shape (twice) onto a spare piece of photo-etch sheet. The outlines were marked using the point of a drawing compass.

NOTE: Use the mounting lugs on the 'Gaspach' guns to mark the two 'fold' lines on each template.

These shapes were cut from the photo-etch sheet using sturdy nail scissors. Flatten any distortion, due to cutting, by placing the cut out onto a hard flat surface (e.g. ceramic tile). Place onto the cut out something hard and flat and press down with a twisting pressure onto the cut out.

File or sand away any burrs or slight distortion from the edges of the cut out.

Fold up the two sides of each cut out to form the basic bracket shape. **NOTE:** For this I used a purpose made photo-etch bending tool - the BUG RTH hold and fold (SM002).



The next stage is to profile and drill out the lightening holes in the bracket.

Use plastic sheet of various thicknesses to make up a rectangular packing block that will fit between the two sides of the bracket. This will provide support during subsequent work.

Position the bracket onto the gun mounting lugs then locate the gun into the trough in the decking and with the rear face of the bracket against the engine bulkhead. Note if the end of the bracket sides extends beyond the mounting lugs on the gun. Also note the position of the holes in the mounting lugs.

Remove the bracket from the gun and insert the packing block between the sides of the bracket.

Using a hard point, lightly tap to create a small indent on each side of the bracket, where the holes in the gun mounting lugs are located.

Drill out a 0.6 mm diameter hole through each indent.

Remove the packing block.

Remove any lift or burrs with a flat needle file or if you have it, a photo-etch diamond file.

Carefully drill out the holes in the gun mounting lugs to 0.5 mm diameter. **NOTE:** Care needs to be exercised when drilling out the lugs as this gun is made of resin and the lugs can easily be broken off.

Check fit the bracket to the gun mounting lugs by inserting a short length of 0.5 mm diameter micro-tune (Albion Alloys MBT05) through the bracket and mounting lugs. *Do not use force - if the tube can't be easily inserted, open up the holes slightly until it can.*

Remove the bracket from the gun mounting lugs.

Using a hard point, lightly tap to create a line of three indents in the centre of the bracket mounting face.

Holding the bracket with tweezers, drill out 0.6 mm diameter holes through each indent.

Drill out the hole at the top of the three using a 1.0 mm drill.

Remove any lift or burrs with a flat needle file or if you have it, a photo-etch diamond file.

Insert the packing block between the sides of the bracket.

Using a hard point, lightly tap to create a line of three indents, in a curve, on each side of the bracket.

Drill out these six indents using a 0.6 mm diameter drill.

Remove the packing block.

Remove any lift or burrs with a flat needle file or if you have it, a photo-etch diamond file.

Insert the packing block between the sides of the bracket.

Using a flat needle file or if you have it, a photo-etch diamond file, profile around the bracket ends where the gun mounting lugs locate.

Using a half-round needle file, file a curve in the sides of the bracket to follow the line of the three drilled holes.

File a slight step at the top of the bracket mounting face.

Finally remove any lift or burrs with a flat needle file or if you have it, a photo-etch diamond file.



Repeat this procedure for the 'Balloon Gun', which will be located in the right gun trough of the rear decking panel.

With the two guns temporarily positioned correctly, secure the brackets to the bulkhead using thin CA adhesive.

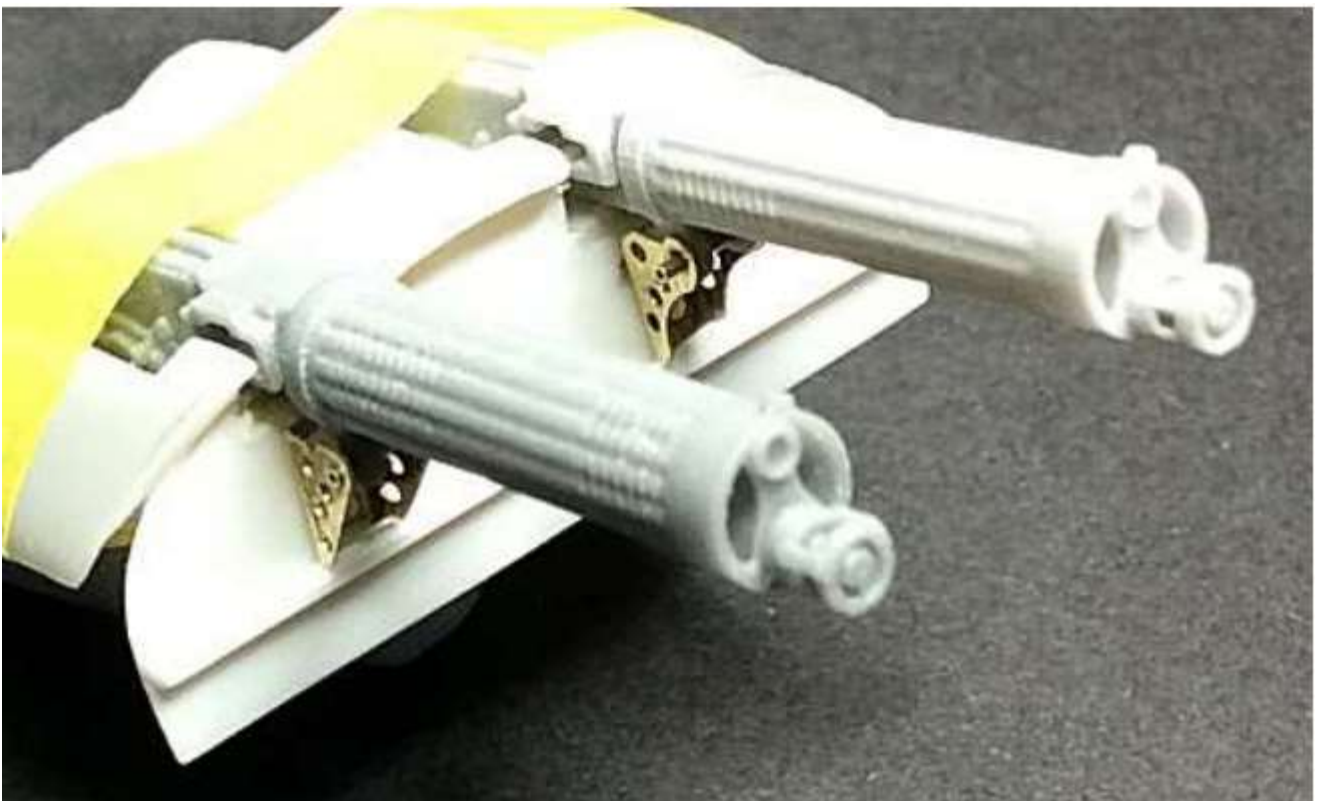

- 11j. **Ejector chutes:** The left machine gun ejector chute took the spent ammunition rounds out to the left side of the fuselage and away from the pilot. However the right gun ejector chute was located under the forward decking panel. This chute is not modelled on the kit decking panel.

On the decking panel, adjacent to where the ejector housing is on the right gun, mark then scrape out a shallow recess, using a small, sharp modelling chisel..

Using 0.2 mm thick plastic card, cut a strip to fit the width of the hole and bend it slightly to form a curve.

Cement the strip into the recess so it curves down and away from the gun ejector housing and into the panel.



12. **Wheels:**

The kit supplies generic sized wheels for the Spad, but I decided to use the larger wheels for this aircraft from 'Aviattic' - 1:32 Spad XIII 65 mm tyre wheels (ATTRES 023). However these wheels need to be modified to fit the kit axle. Also the access hole in the outer covering does not have spoke detail included.

Axle hole - drill through the wheel axle hole using a 1.3 mm diameter drill.

Wheel spokes - Cut a short lengths of 0.3 mm diameter micro-tube (Albion Alloy's NST03) and attach inside the outer wheel cover access hole and inline with the premolded spokes detail on the cover.

Inflation valve - Cut a short length of 0.3 mm diameter micro-tube (Albion Alloy's NST03) and attach it inside the outer wheel cover access hole and between the added spokes.



13. Ventral Panel:

The Ventral panel is located on the bottom of the fuselage and is essentially the panel covering the main fuel tank assembly. The panel also has pre-mold detail for the cap for fuel tanks, the fuel 'rip' panel, three metal support straps and four panel fasteners. I decided to modify these details as follows:

Fuel tanks cap:

The pre-molded stub on the fuel tank sump lacks any cap detail and the stub itself is too deep.

File or sand the filler stub to reduce its height.

Cut out a small disc (just slightly larger than the stub diameter) from 0.2 mm thick plastic card and cement to the stub.

Drill a 1.2 mm diameter hole through a piece of 0.2 mm thick plastic card. Cut a short and thin strip of the card through the drilled hole.

Attach the plastic strip (on its edge) across the plastic disc. This will represent the 'turner' of the cap.



Metal support straps:

The three pre-molded support straps are just a little too thick, but if reduced in thickness, the detail for the oblong lightening holes would be lost.

Drill through three holes along each oblong hole in each strap, using a 0.8 mm diameter drill.

Drill at an angle across each set of the holes (slots), to break through the plastic.

Carefully scrape away the slots to make them as parallel as possible.

Using a flat or curved scalpel blade, scrape away the surface of each support strap until a more realistic thickness is achieved.

Apply a light coat of Tamiya Extra Thin cement, to merge and solidify the surfaces of the cut plastic.

Apply masking tape on the inside face of the panel, across all three slots.



From the outer face of the panel, fill each slot with modelling putty (I used 'Masilla Plastica').

Using a suitable tool with a rounded end (e.g. a paper embossing tool), gently wipe away the top surface of the putty in each slot, leaving it just below the surface of the support straps. Leave the masking tape in position, as it will not be seen and will act to support the infill of modelling putty in each slot. If any air bubbles appear, use the tool to gently 'tap' out the bubbles.

Once the putty has dried fully, carefully sand away the surface of each support strap to remove any over-spill of putty.

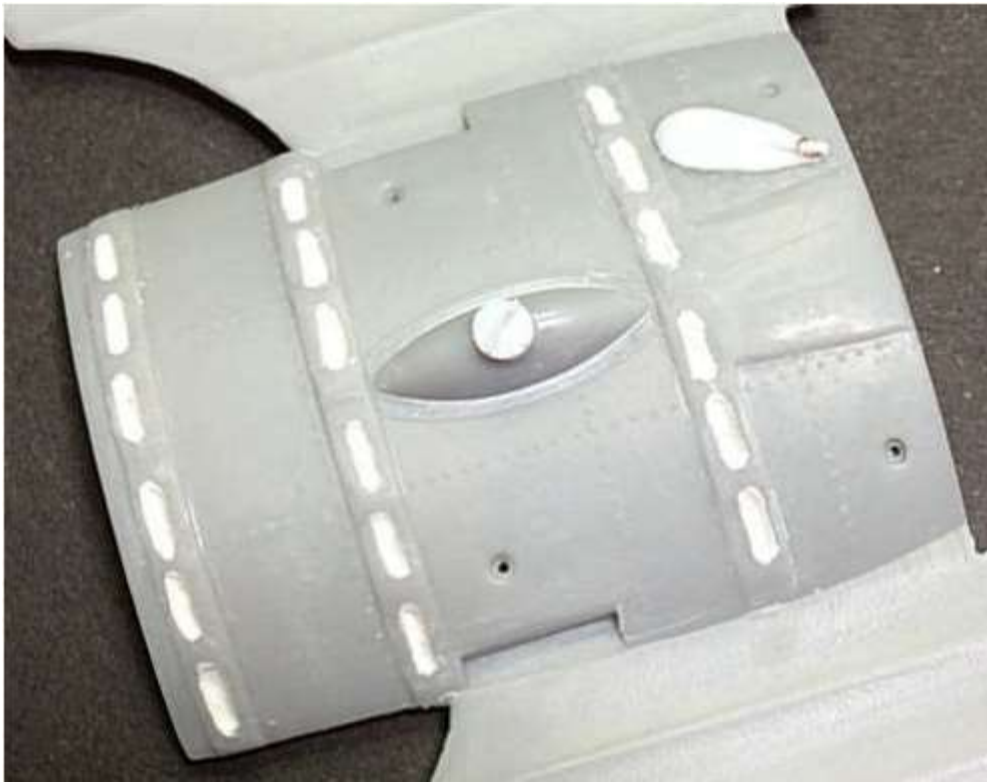

Panel fasteners: The panel has four pre-molded 'dimples' to represent the four panel fasteners. These can be modified to more accurately depict these fasteners. In the centre of each 'dimple', drill through a hole using a 0.5 mm diameter drill.

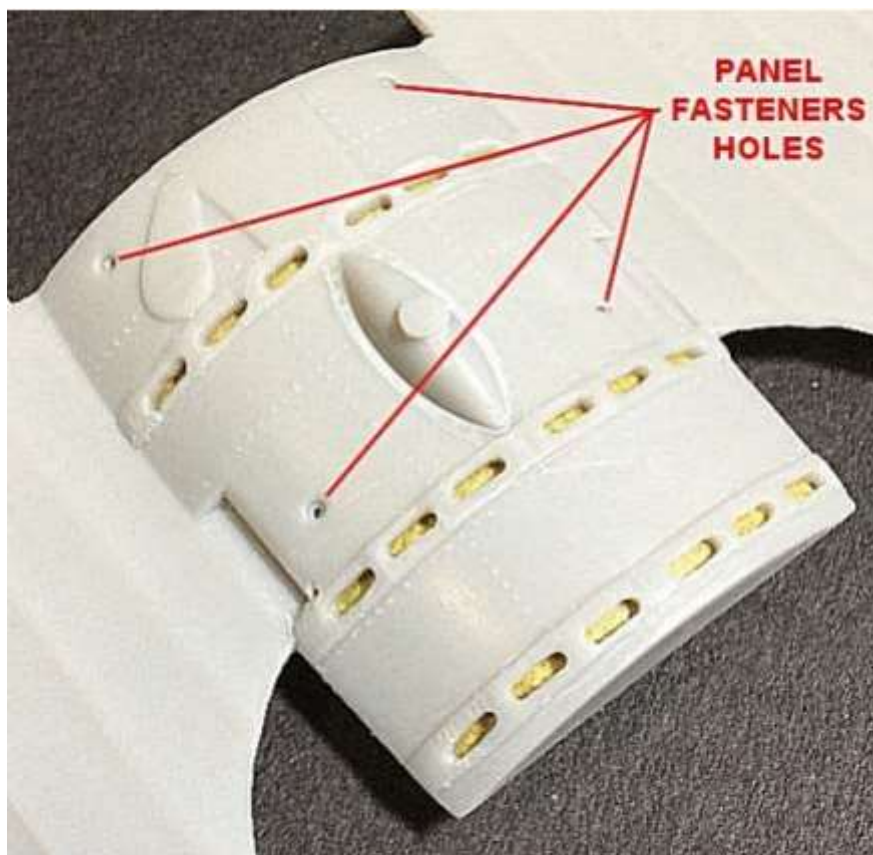

Later in this build - Once the panel is fitted to the model, and painted, short lengths of 0.5 mm diameter micro-tube will be inserted into the holes, followed by a suitably sized 'RB Motion' aluminium nut. These will represent the bolt fasteners for the panel.

Fuel jettison rip panel:

The fuel rip panel is pre-molded on the ventral panel, but has no detail for the operating cable.

Sand off the pre-molded rip panel from the ventral panel at underside of the lower wing.

Using 0.2 mm thick plastic card, cut out the rip panel shape but leaving a thin tail at the narrow end of the panel.

Cement the rip panel in position on the ventral panel where the pre-molded panel was located.

Create the operating cable ring - Using thin copper wire, loop it around 0.6 mm diameter drill and twist to form the ring. Cut off the twisted wire tail, leaving just the ring.

Place the ring onto the panel tail and bend the tail over and cement onto the panel.

Drill a 0.4 mm diameter hole inboard of the right rear undercarriage strut (for the operating cable).

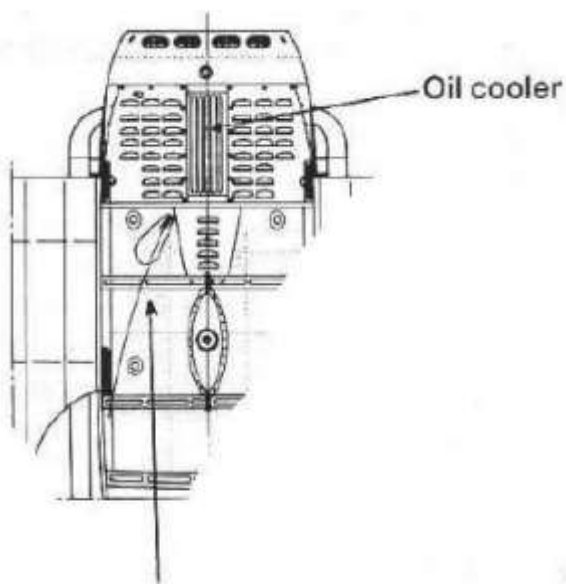
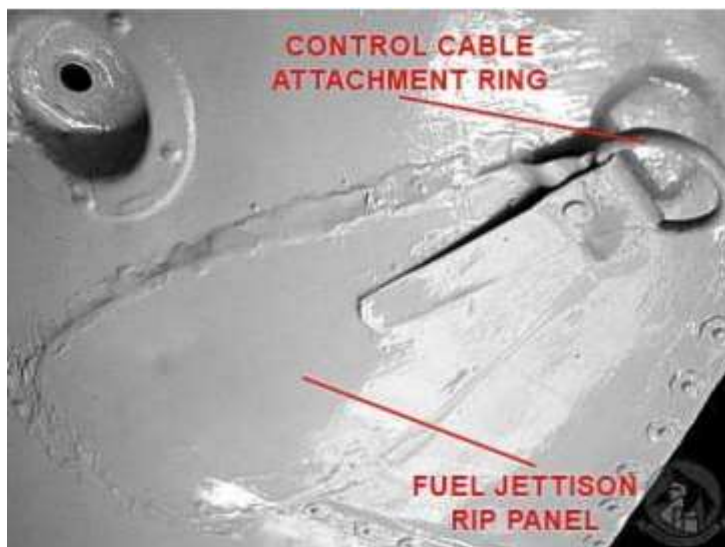

Rip panel and cable to cockpit for emergency fuel jettison

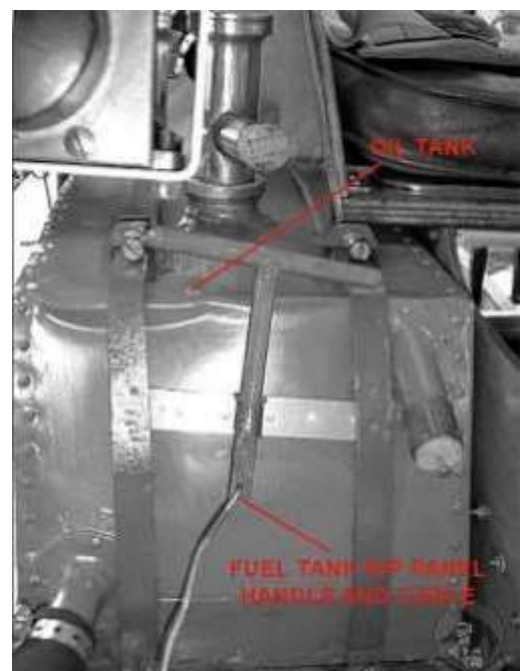

Water pump cooling louvres:

The centre forward area of the ventral panel, adjacent to the fuel rip panel, has 5 louvres for cooling the engine driven water pump, which was located above the panel. These 5 louvres are not detailed on the ventral panel.

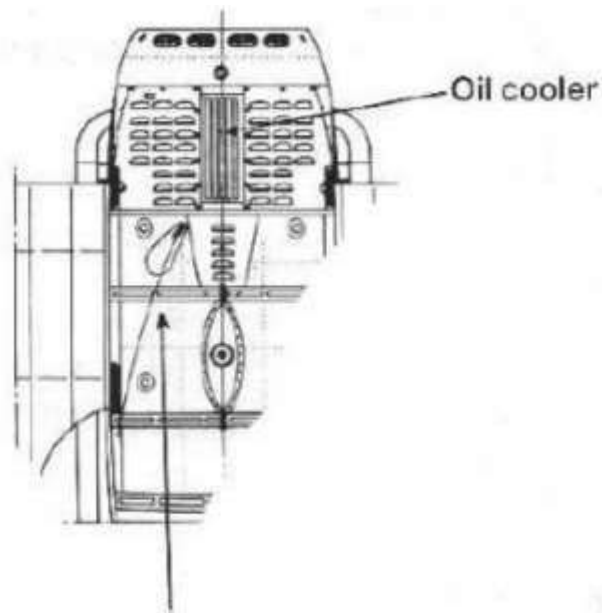

Rip panel and cable to cockpit for emergency fuel jettison

Mark the 5 louvre locations with a pencil.

Drill three 0.5 mm diameter holes, angled towards the forward edge of the wing, along each pencil line.

Using a 'broken' drill as a reamer, drill across the holes from each side, to remove the remaining plastic.

Remove any tags etc of plastic using a sharp needle, held in a pin chuck.

Finally apply a very light coat of the Tamiya Extra Thin cement over the louvres, to smooth out worked areas.



14. Wing inboard 'H' support struts:

The wing support struts on the Spad XIII were quite different in design from contemporary aircraft of the period. The outer support struts were conventional but the inboard support struts were different, in that they were of an 'H' design with a central strut joining the front and rear struts. The flying and landing rigging wires crossed at the centre point of the inboard struts, rather than being attached at the wing attachment points for the struts. Each support strut was attached the wings with metal brackets, which included the rigging wire anchors.

The wing support struts that are supplied with the kit lack detail and the size and shape of the two inboard strut assemblies seem to be lacking accuracy. None of the struts have the wing attachment brackets or the classic four colour banding around the struts. In addition, the inboard 'H' struts seem to be 'profiled' too much at the centre and too thin overall, making them not only inaccurate but very flimsy and weak. Photographs of the actual aircraft indicate these struts were more parallel in design and larger than the kits struts, when compared to the outer struts.

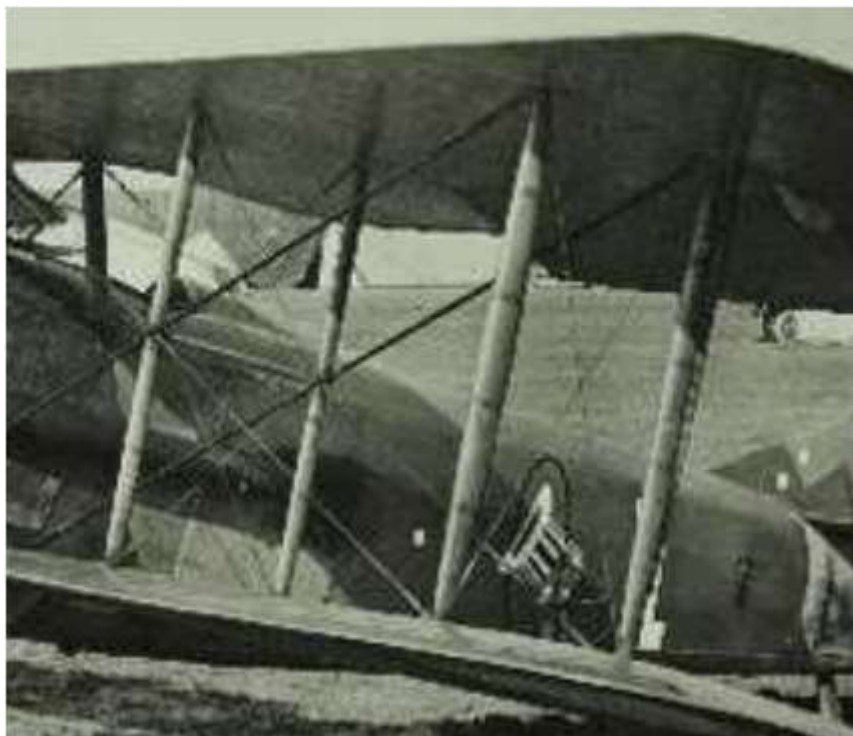

Fabricating the inboard 'H' struts:

To fabricate the inboard 'H' struts I used the following materials:

- Albion Alloy's 1.2 mm diameter brass micro-tube (MBT12)
- Albion Alloy's 0.8 mm diameter brass micro-tube (MBT08)
- Albion Alloy's 0.5 mm diameter brass micro-tube (MBT05)
- Albion Alloy's 'Connecto' (C08)
- Albion Alloy's 'Strutter' (tool for creating aerofoil shape from micro-tube).

Cut four lengths of 1.2 tube to slightly longer than a vertical strut (from the centre bar) on the kit 'H' strut.

Place all four tubes onto a length of 0.5 mm tube.

Using the 'Strutter' crush the four tubes, but not enough to flatten the 0.5 mm tube.

Remove the four tubes from the 0.5 mm tube.

Cut a length of 0.8 mm tube to the same length of the centre bar of the kit 'H' strut.

Remove two cross section parts from the 'Connecto' set.

Insert each 'Connecto' part into the ends of the 0.8 mm tube.

Position the 'crushed' 1.2 mm tubes onto the legs of the 'Connecto' parts to form the basic 'H' strut shape.

NOTE: The following steps are for soft soldering the tubes. However CA adhesive could be used as an alternative, but caution would be need to prevent the tubes becoming stuck to the surface the assembly is laid on.

Place the tube assembly onto a heat resistant surface, such as a glazed tile.

Using the kit 'H' strut as a guide and masking tape to hold the assembly rigid, position the tubes to match the strut shape.

Soft solder the 'Connecto' joints to create a rigid 'H' strut.

Remove the masking tape and 'H' strut from soldering surface.

Into each open end of the vertical tubes, insert a length of 0.5 mm tube.

Soft solder the 0.5 mm tubes to the vertical tubes.

Carefully sand away any residual solder from around the various joints.

Cut away the two protruding 'Connecto' tangs and file or sand the edge to blend with the aerofoil sections.

In the centre of each of the vertical sections, adjacent to the cross-bar, drill a 0.4 mm diameter hole (for passing through the single landing wires).

Repeat to create the other 'H' strut assembly.



15. Wing outboard rear support struts:

The forward wing outboard struts supplied in the kit are shaped and sturdy enough to be used. However I decided to scratch build the rear wing outboard struts, as these will support the two aileron operating rods and therefore needed to be more sturdy.

To fabricate the rear outboard struts I used the following materials:

Albion Alloy's 1.2 mm diameter brass micro-tube (MBT12)

Albion Alloy's 0.6 mm diameter brass micro-tube (MBT06)

Albion Alloy's 'Strutter' (tool for creating aerofoil shape from micro-tube).

Cut two lengths of 1.2 mm tube to the same length of the kit rear outboard strut.

Place the tubes onto a length of 0.6 mm tube.

Using the 'Strutter' crush the tubes, but not enough to flatten the 0.6 mm tube.

Remove the four tubes from the 0.6 mm tube.

Cut two lengths of 0.6 mm tube to slightly longer than the length of the created tubes.

Place the 0.6 mm tubes through the created strut tubes so the protruding ends are central in strut tubes.

Soft solder the tubes to the strut tubes.

File or sand a taper from the centre to both ends of the strut tube, but only on one side (the other side is straight to mount the aileron control rods).

Doing this will cut through the wall of the strut tube, exposing the internal bore. Once you are happy with the profile of the strut, fill the exposed 'gaps' with soft solder or modelling putty, then re-profile the shape.



16. Aileron controls:

The ailerons on the Spad XIII were only on the upper wing and were cable and rod operated. A control cable from the pilot's control column was routed out at each side and through the lower wing, connecting to a tubular bell crank assembly. The bell crank pivoted on the rear of a vertical support plate, which also acted to connect the rear landing wire to an extension strap attached to the bottom of the outer, rear wing strut. The bell crank was connected to the bottom of an operating rod, which was attached to the back of the outer, rear wing strut. This rod connected to the aileron operating bell crank, being recessed in the upper wing and attached to the underside of the aileron.

As the pilot moved the control column, the cables operated the bell crank, which pivoted, moving the rod on the rear of the outer wing strut either up or down. This in turn moved the aileron bellcrank attached to the aileron, moving it up or down as required.

The kit supplied items are a basic bell crank and the operating rod/aileron bell crank assembly. These lack completeness and detail and require modification to make the aileron controls more credible.

Operating rods:

To fabricate the aileron operating rods I used the following materials:

Albion Alloy's 1.0 mm diameter brass micro-tube (MBT10)

Albion Alloy's 0.8 mm diameter brass micro-tube (MBT08)

'Gaspach' 1:48th scale RAF Late turnbuckles.

Cut a length of 1.0 mm diameter micro-tube so it is approximately 5 mm shorter than the body of the created rear wing strut.

Cut a length of 0.8 mm diameter micro-tube and secure it into the 1.0 mm tube, to leave approximately 1.0 mm protruding.

File away the flat end of a 'Gaspach' RAF Late style turnbuckle, then secure the shank of the turnbuckle into and end of the 0.8 mm tube, using thin CA adhesive.

Attach the tube to the rear (straight) edge (not the profiled edge) of the wing rear support strut, using thin CA adhesive or 'VMS' Fleky 5K CA adhesive. The tube should extend just above the top of the strut body, so that it will insert into the slot in the upper wing. The bottom of the rod should be 6 mm from the bottom of the strut body. **NOTE:** The turnbuckle should be at the bottom of the strut assembly and its end fitting aligned across the wing (not aligned to the wing leading/trailing edges).

Repeat for the other wing rear support strut.



Wing Slots:

1. The top of the operating rods and the aileron bell cranks were semi-recessed in to slots in the underside of the upper wing. These slots are not pre-molded into the wing.

2. The pre-molded slots in the upper surface of the lower wing are for mounting the tubular bell cranks. However these slots are in the wrong position, being inline with the wing strut location points. The bell cranks connect to the operating rods on the rear of the wing struts and therefore their mounting slots need to be located rear wards in the lower wing.

Drill into (but not through) the wing strut location points on both wings, using a 0.6 mm diameter drill (in preparation for fitting the struts later in the build).

Cut a 'test' length of 1.0 mm diameter micro-tube.

Fill in the two pre-molded slots in the lower wing adjacent to the rear support strut location points (not required). Once set, sand flush with the wing surface.

Insert a rear support strut into its location point and hold the cut 1.0 mm test tube against the struts rear edge.

Mark a line on the lower wing for the aileron bell crank slot. The line should centre on the 1.0 mm tube and span 3 mm equally each side of the filled in pre-molded slot.

Drill a row of holes part way into the wing (not through it) and along the marked line using a 0.8 mm diameter drill.

Cross drill the holes to create a basic slot. Clean up the slot using a flat scalpel blade.

Drill a 0.6 mm diameter hole through the wing, midway along the slot (for mounting the aileron bell crank).

Repeat on the other side of the lower wing.



Using the same technique, created a slot on the underside of the upper wing. The slot should start close to the rear strut location point and end approximately 2 mm from the wing trailing edge.

Repeat on the other side of the upper wing.



Bell crank assemblies:

1. The kit supplied aileron bell cranks are molded in flat section, but appear to be slightly over scale in size.
2. There is no provision in the kit for the bell crank and landing wire support or its mounting location.
3. The kit does not supply the extension strap for the rear landing wire.

Bell crank:

To fabricate the aileron bell crank assemblies I used the following materials:

Albion Alloy's 0.4 mm diameter brass micro-tube (MBT04)

Albion Alloy's 'Connecto' (C04)

NOTE: Use the kit supplied part as a size guide.

Cut two lengths of 0.4 mm diameter tube (longer than required) and connect at a right angle, using a part from the Albion Alloy's 'Connecto' set.

Soft solder the joint and sand off any residual solder.

Cut a length of 0.4 mm diameter tube (for the cross bracing piece) and secure in position using soft solder or 'VMS' Fleky 5K CA adhesive.

Cut away the excess tube, but leave a short tail at the bottom (for inserting into the wing slot).

Repeat for the opposite bell crank.



Bell crank and landing wire support:

Cut a 2 mm wide strip of spare photo-etch brass and 'anneal' (soften) by holding over a flame.

Wrap the strip around a length of 0.4 mm diameter micro-tube and pinch the strip to grip the tube.

To gauge the height required for the support, temporarily dry fit a rear strut assembly and the bell crank in their locations on one side of the lower wing.

Measure the height of the top inboard corner of the bell rank from the surface of the lower wing.

Mark the height for the two 'legs' of the support and bend the ends outwards, to form the base mounting of the support.

Holding the legs together (at the bent ends), secure the strip together using soft solder or thin CA adhesive.

Drill two lightening holes into the support, using a 0.6 mm diameter drill, both being central with the top hole just below the crimped tube at the top.

Elongate the upper hole across the support, for passing through the landing wire strap.

Landing wire strap:

Cut a length of 0.5 mm diameter micro-tube.

In one end of the tube, secure a 'Gaspatch' 1:48th scale 'One End' turnbuckle, using thin CA adhesive.

Cut the other end on the tube so when inserted through the top hole in the support, it rests against the bottom of the wing rear support strut and extends out from the top of the support.

Using flat nosed pliers, flatten the tube up to the support strut.

Test assemble:

On one side of the lower wing, dry fit an 'H' strut, wing rear strut, the aileron bell crank support on a tiny piece of 'Bluetack or similar' and the landing wire strap. Ensure the landing wire run will align correctly between the strap and previously drilled hole on the 'H' strut at the cross bar joint'.

NOTE: These parts will be finally fitted later in the build of this model.

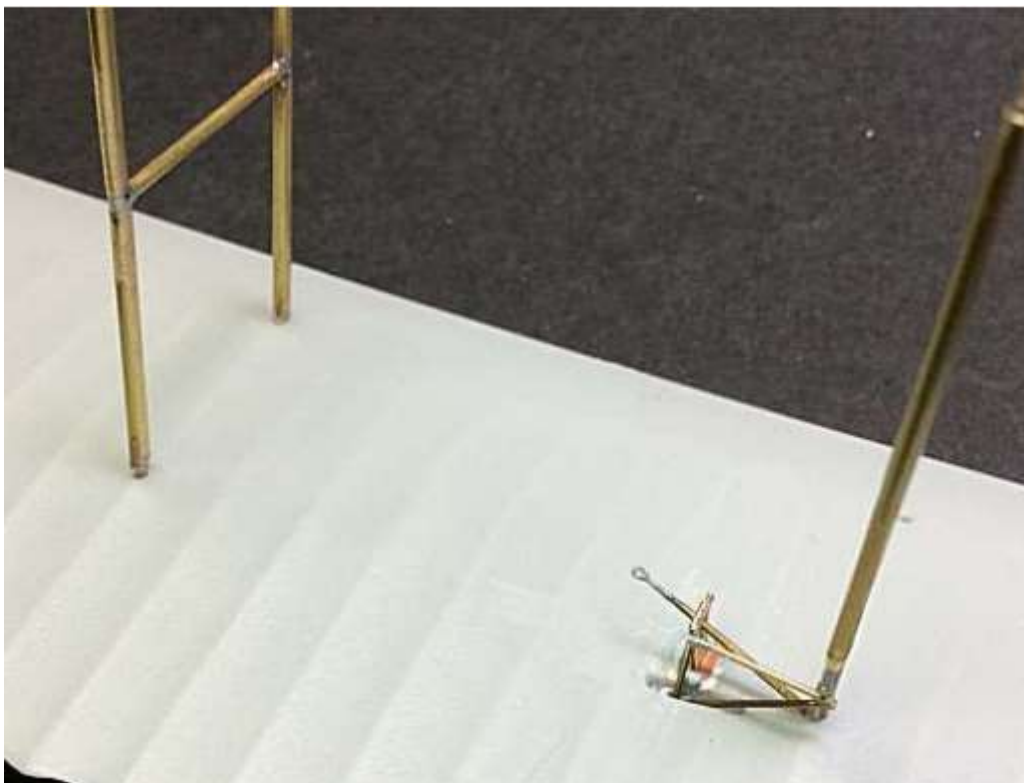

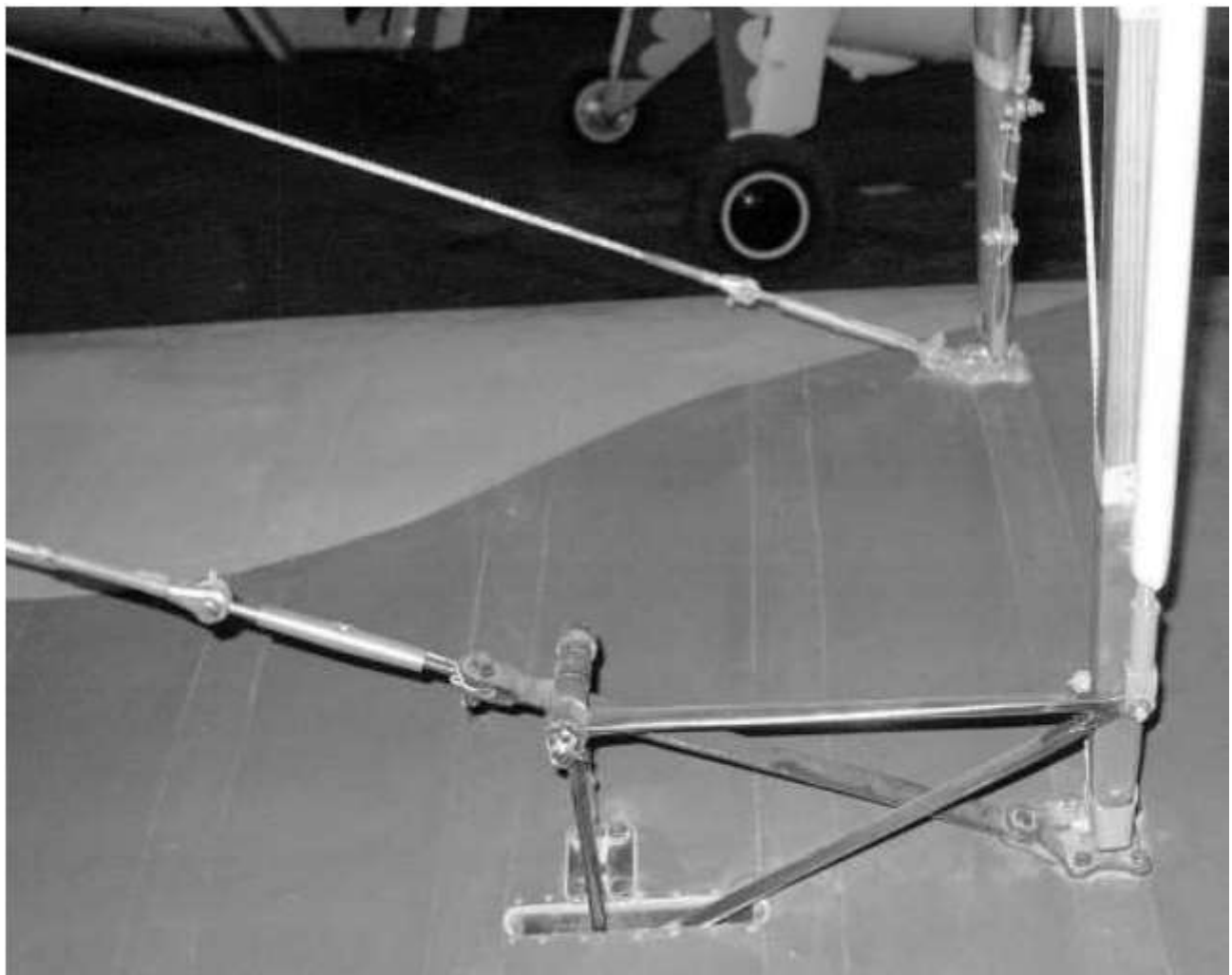
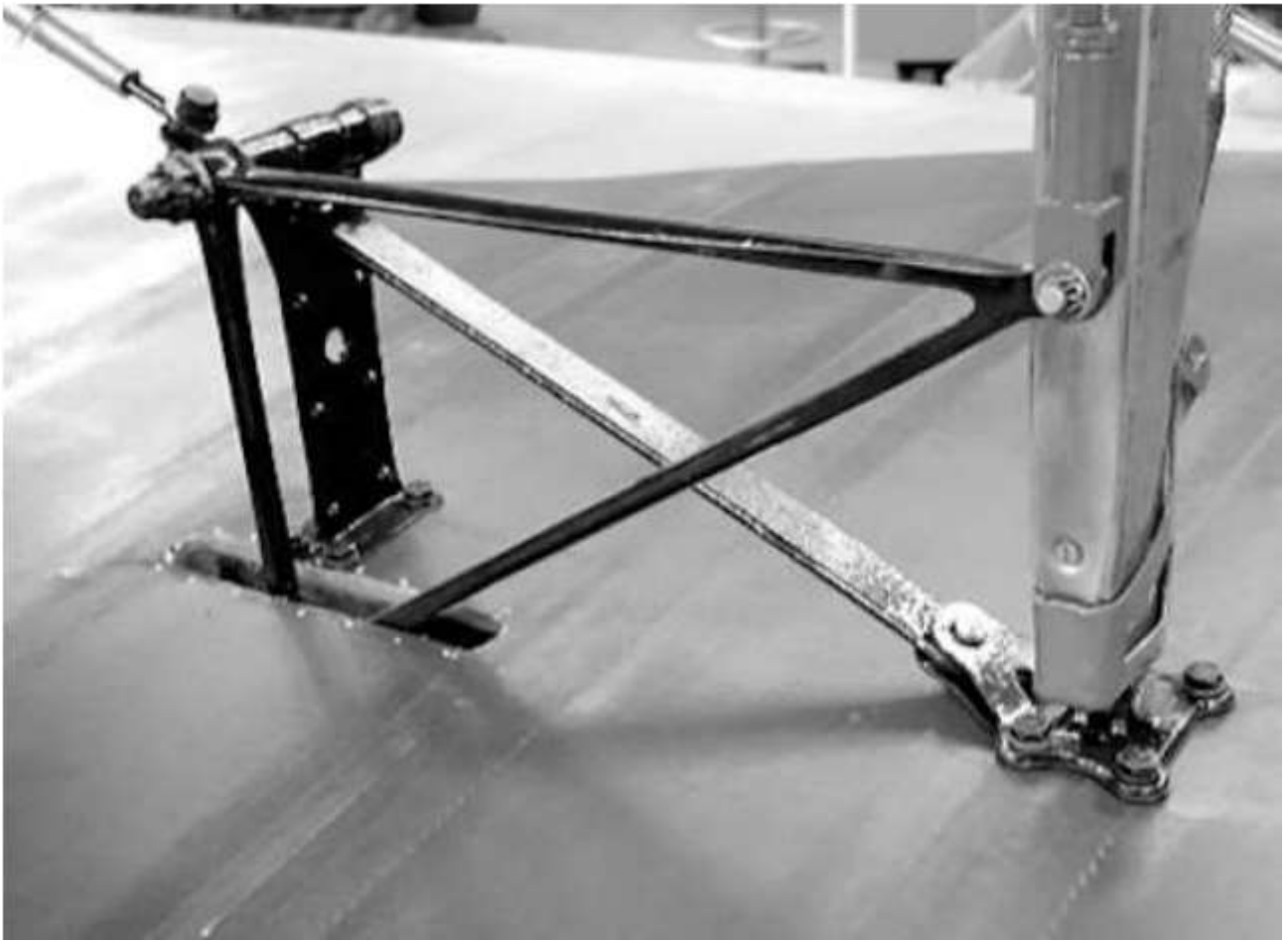

17. Rigging points:

The external rigging for this aircraft is quite complex. The list below details the rigging that is required:

1. Single crossed bracing wires between the outer wing support struts (on each side).
2. Single crossed bracing wires between the top and bottom halves of the inner 'H' wing support struts (on each side).
3. Single crossed bracing wires between the fuselage cabane struts (on each side).
4. Twin flying wires from lower wing root to top of outer wing support struts (a pair forward and rear on each side).
5. Single landing wires from top of fuselage cabane struts to bottom of outer wing support struts (one forward and rear on each side).
6. Twin bracing wires between the top of the forward fuselage cabane strut and the bulkhead at the rear of the engine bay.
7. Single crossed bracing wires from adjacent to the top of the undercarriage struts to the axle fairing.
8. Single operating 'pull' wire from rip panel on the ventral fuel tank to the top of the right rear undercarriage strut.
9. Single control cable from the rudder control horns to the fuselage (on each side (there were no exposed elevator control cables)).

NOTE: Turnbuckles from 'Gaspatch' (Type A 1:48th scale) were secured with thin CA adhesive at the correct angle into 0.3 mm diameter holes drilled into the wings.

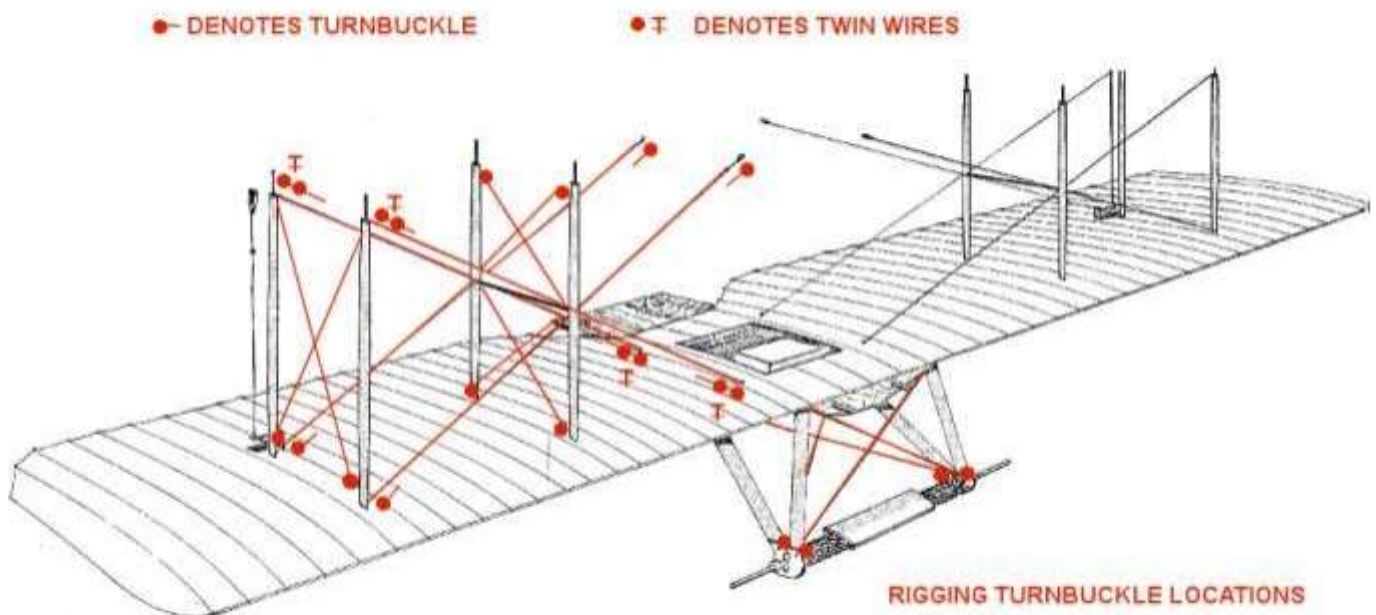

POINTS 3 and 6

● DENOTES TURNBUCKLE

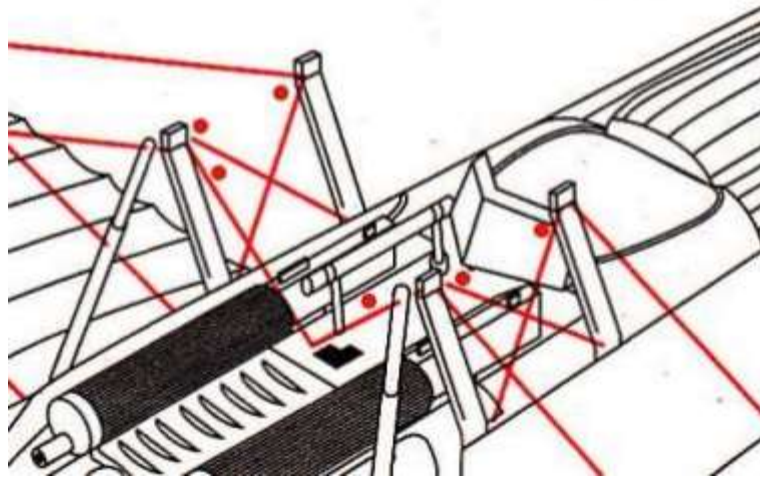

General Rigging



Wing support "H" strut

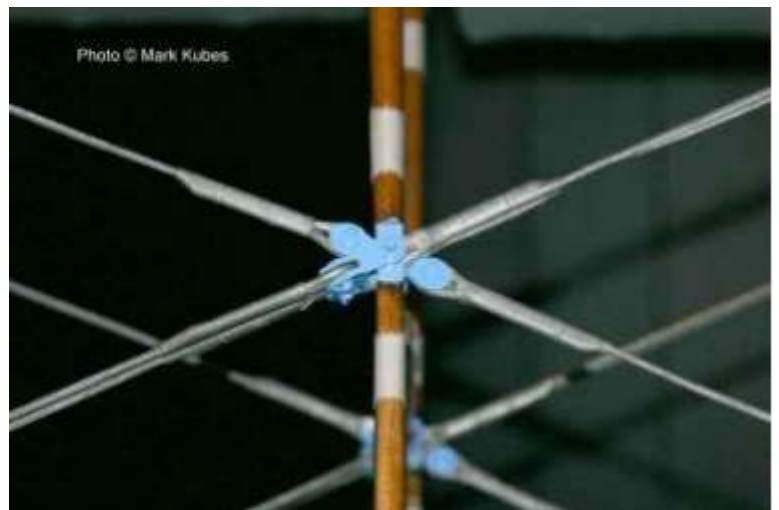
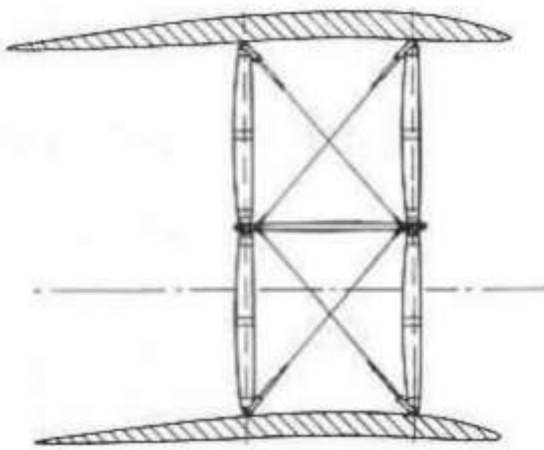

Outer wing strut tops



Undercarriage bracing



POINTS 7

● DENOTES TURNBUCKLES

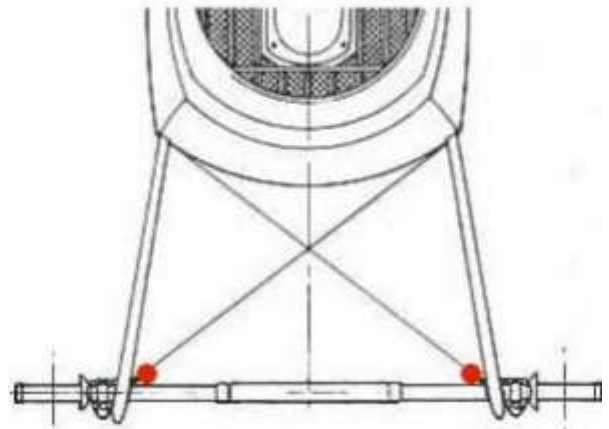

Cabane struts



2. Single crossed bracing wires between the top and bottom halves of the inner 'H' wing support struts (on each side) - top and bottom of centre cross bar only.

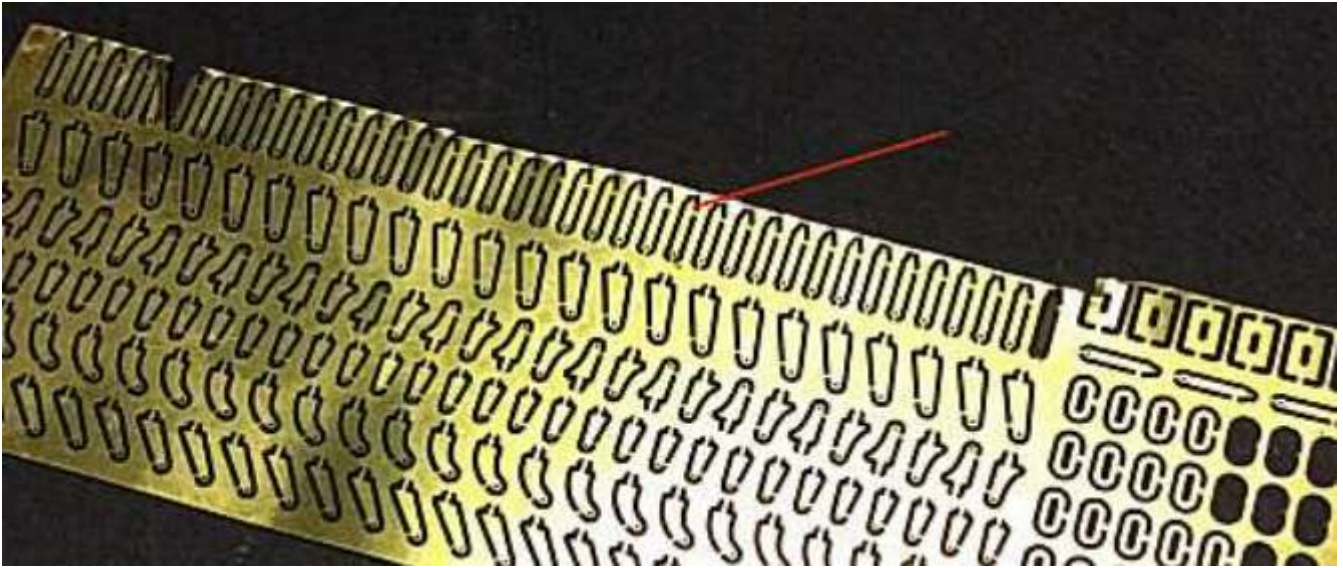

To replicate the attachments for the cross bracing wires I used photo-etch items from the 'Part 1:48 scale WW1 Aircraft Control Horns (S48-087)' set.

I used a shielded razor blade to cut each item off the photo-etch sheet, then cut each in half, but at the angle required to diagonally align between the strut corners. The usual CA adhesives will secure photo-etch but has a tendency to produce a 'brittle' joint which can lead to photo-etch items being 'knocked off' the model. In this instance I chose to secure each item in position using 'Flexy 5 CA' adhesive, a thicker CA adhesive, which when set has more 'give' in the joint than normal CA adhesive.

Below is a photograph of an 'H' strut with two of the four corner attachments fitted



4. Twin flying wires from lower wing root to top of outer wing support struts (a pair forward and rear on each side).
5. Single landing wires from top of fuselage cabane struts to bottom of outer wing support struts (one forward and rear on each side).

To replicate the attachments for each pair of twin flying wires on the wing 'H' support struts, I used 0.4 mm diameter brass micro-tube (Albion Alloy's MBT04). Four short lengths of the tube were cut and bent into a 'U' shape. A 0.2 mm diameter drill was used to clear the open ends of each tube. The tubes were then secured, at the correct diagonal angle for the flying wires, to either side of the wing 'H' strut centres (where the cross bar is attached) using 'Flexy 5 CA' adhesive.

To aid in achieving the correct angle of the fittings on the 'H' strut, I used a strip of masking tape, on which I marked lines denoting the lower wing, positions of the wing root and strut locations and the upper wing (using the struts to mark the height). This was used to gauge the position of each fitting as they were secured to the 'H' struts. Each fitting in turn was 'tacked' onto the 'H' strut with CA adhesive, the strut held on the inner 'H' strut line and the fitting positioned on the flying wire line. Once aligned the fitting was fully secured in position.

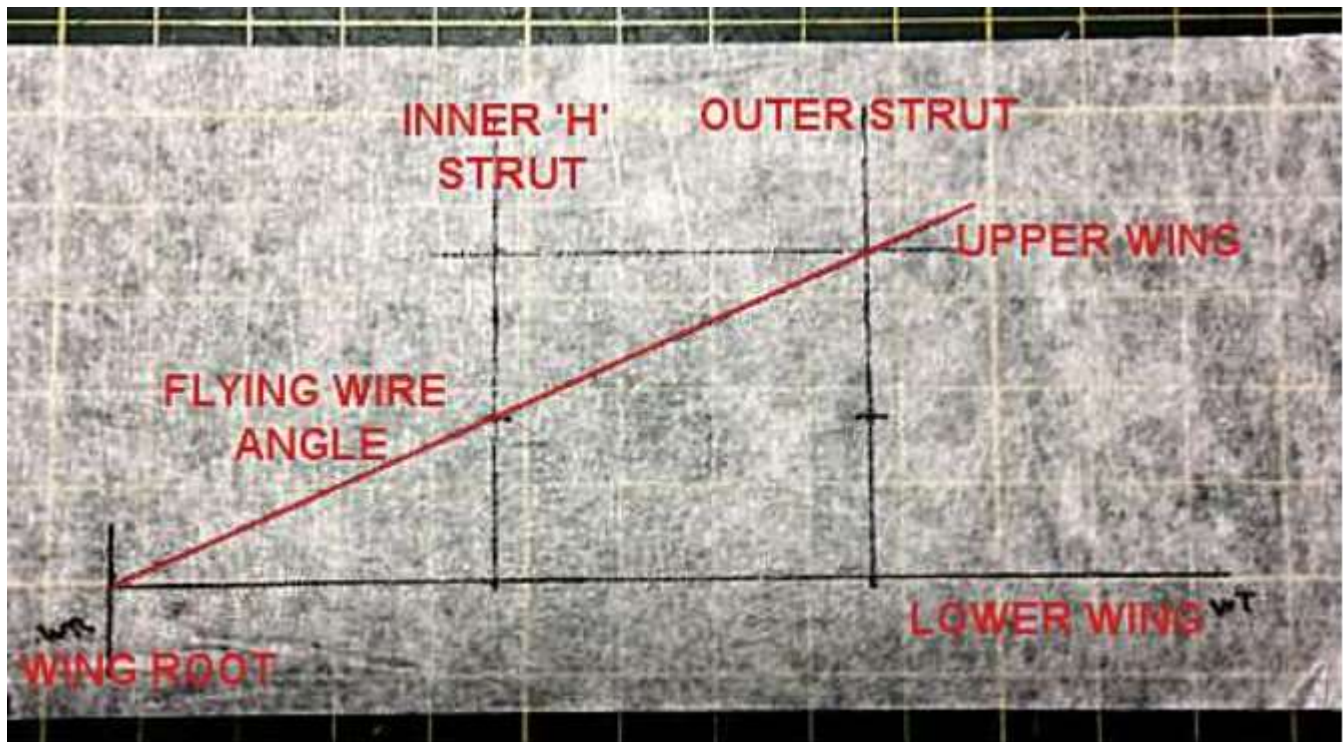

The single landing wires will pass through the previously drilled holes in the wing 'H' strut centres (where the cross bar is attached) and between the twin flying wires.

The following page shows a completed 'H' strut with the four corner bracing fittings, the four twin flying wire fittings and the two holes for passing through the two landing wires.

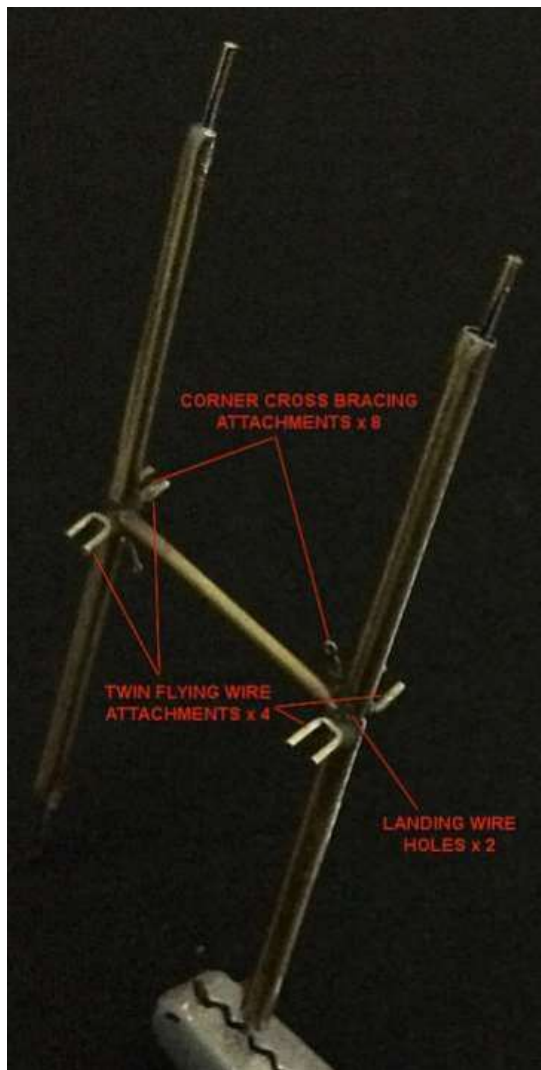

The following rigging will be covered later in Part 12 (Construction) of this build log, using 'Gaspach' 1:48th scale turnbuckles.

6. Twin bracing wires between the top of the forward fuselage cabane strut and the centre of the fuselage decking panel (from each side).
7. Single crossed bracing wires from adjacent to the top of the undercarriage struts to the axle fairing.
8. Single operating 'pull' wire from rip panel on the ventral fuel tank to the top of the right and rear undercarriage strut.
9. Single control cable from the rudder control horns to the fuselage (on each side). There were no exposed elevator control cables.

Rigging 'eyelets':

Some of the rigging wires will be attached to these fittings later in the model build. Attaching the rigging wires to the aircraft surfaces will be achieved using thin copper wire 'eyelets'. The wire is looped around a 0.5 mm diameter drill and the two 'tails' twisted together. Excess tail is cut away and the remaining secured into a pre-drilled hole using thin CA adhesive, leaving just the wire ring exposed, through which the rigging line is passed. These eyelets are required for:

- Fuselage - Single crossed bracing wires between the fuselage cabane struts (on each side).
- Undercarriage - Single crossed bracing wires from adjacent to the top of the undercarriage struts to the axle fairing.

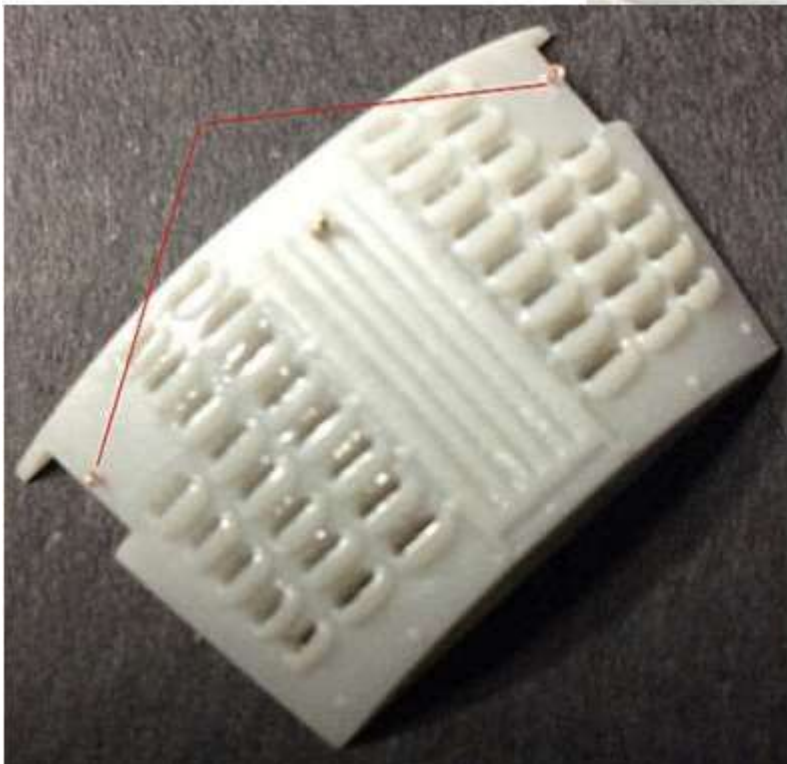
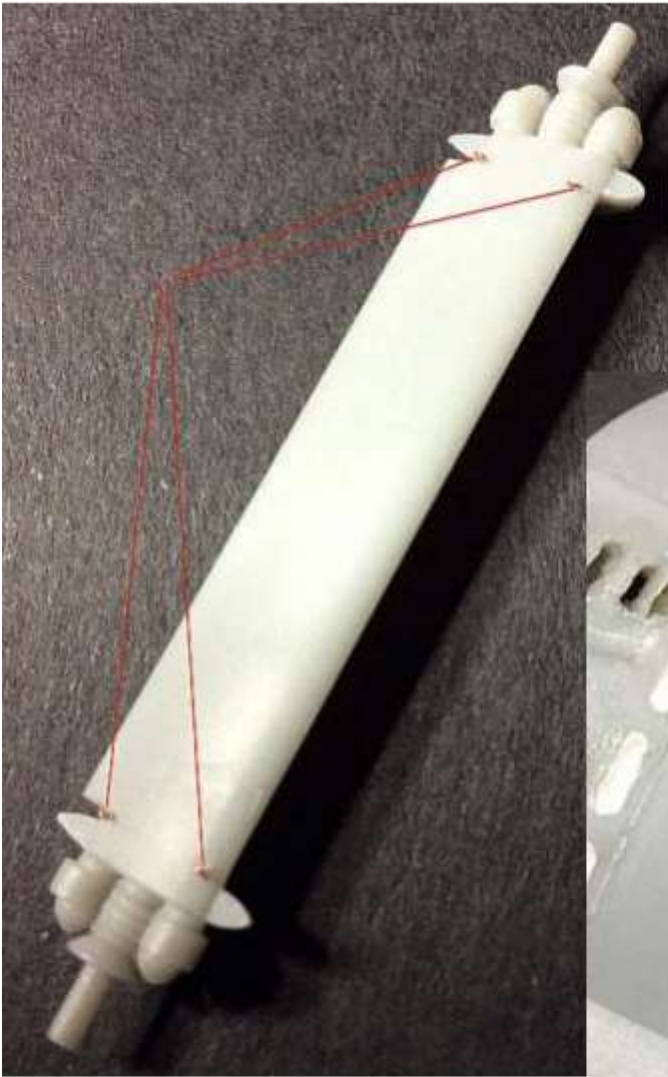

18. Rear fuselage - lifting straps:

The fuselage was lifted at the rear by ground crew, using leather lifting straps, one of which was located on each side of the fuselage side just forward from the tail plane leading edge.

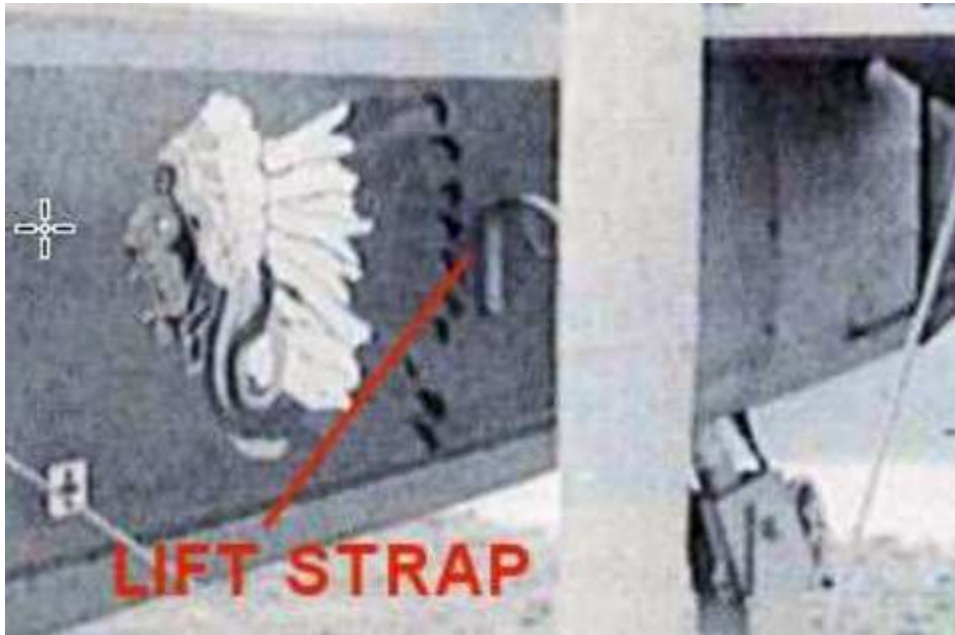

To represent these lifting straps:

Cut two lengths of 0.2 mm thick plastic card approximately 1.0 mm wide.

Bend one end of each around a sewing needle to form a loop.

Cement the loop end onto the strip.

Use a razor blade to trim away any distorted plastic or extruded cement.

Prime with 'AK Interactive' Primer and Micro-filler (AK758) and when dry, with 'AK Interactive' Brown Leather (AK3031).

NOTE: These lifting straps will be fitted to the fuselage later in this build.



19. Gun sight assembly:

The gun sight supplied with the kit is of the 'Aldis' tubular kind, which was fitted to many allied aircraft. However the Spad XIII were also fitted with ring sights, located on a support bar, which was fitted between the two machine guns and rear of the gun muzzles. It was usual for the 'Aldis' gun sight to be positioned on the forward decking and slightly to the right (starboard) of the aircraft centre line. The ring sight was positioned on the support bar and further towards the right machine gun.

Below are photographs of the Spad XIII flown by Capt. Eddie Rickenbacker, which show a typical ring sight and support bar assembly.

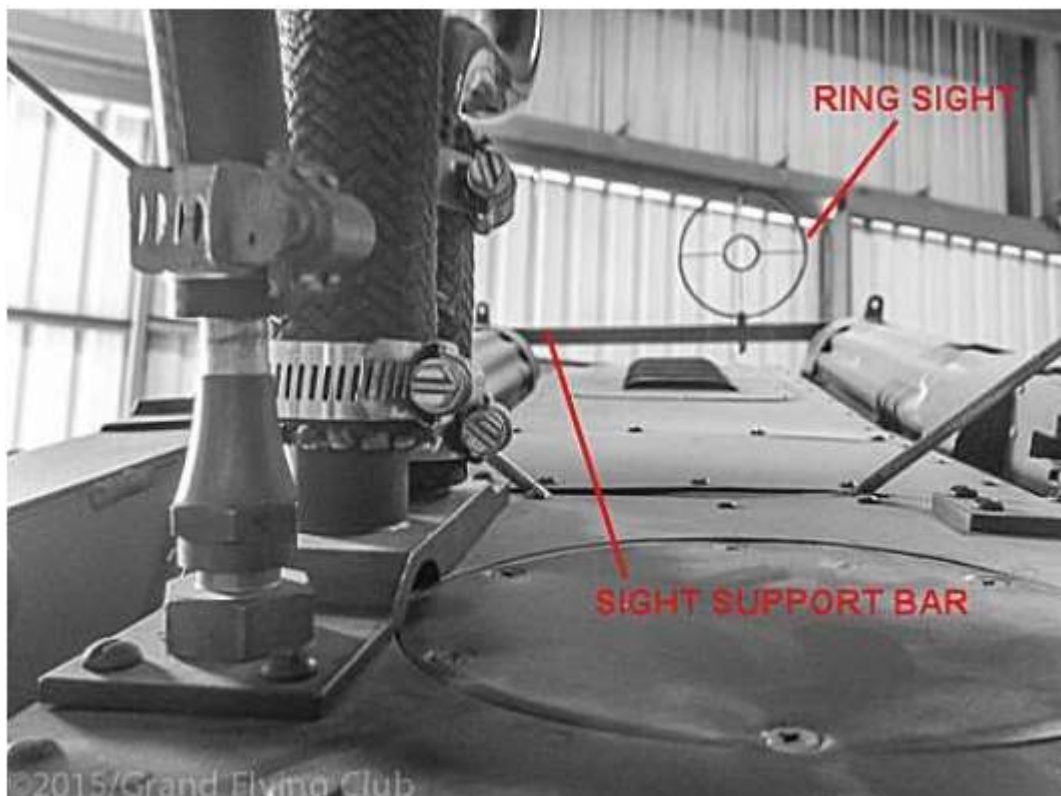
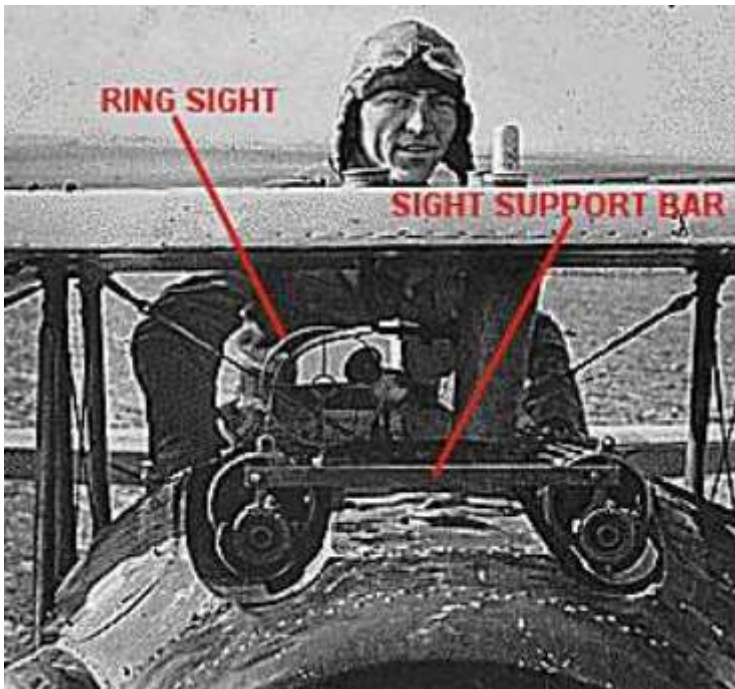

However at least one of the Spad XIII aircraft flown by Frank Like Jnr (No.26 of the 27th Aero Squadron, 1st Pursuit Group) was fitted with what appears to be a 'double' ring gun sight. Also this gun sight seems to have been located centrally on the support bar, between the two machine guns. This is the aircraft pictured below and the subject of this model build.

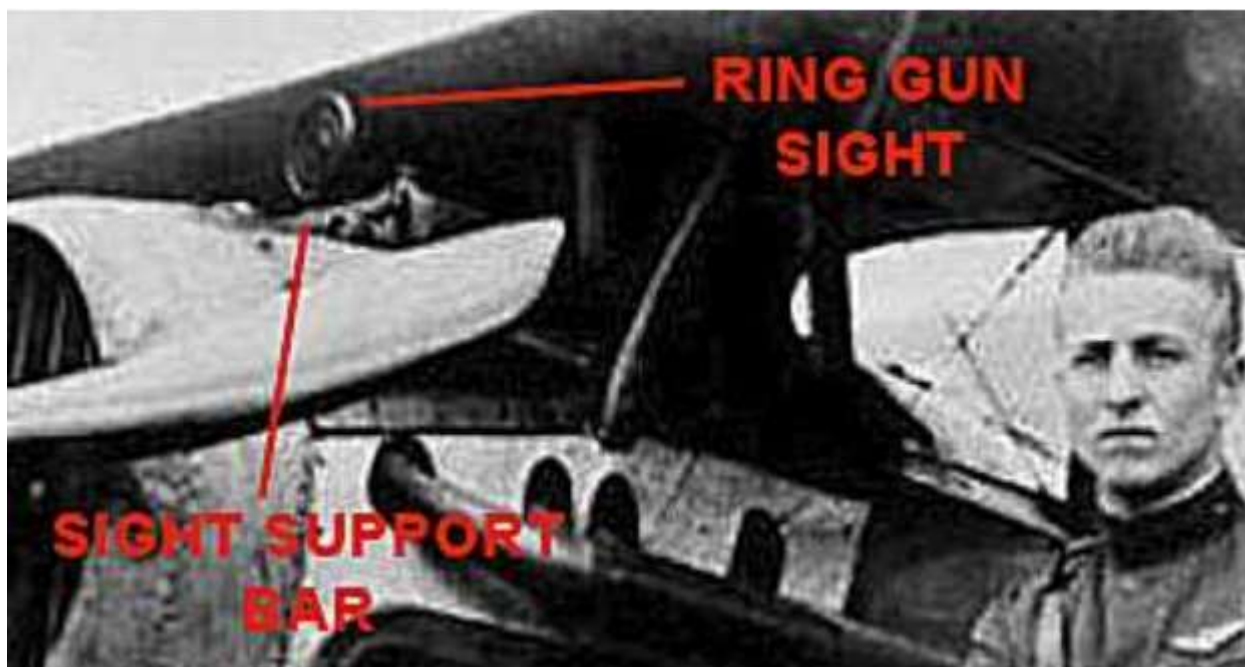

To represent the sight and support bar:

Above the muzzle of each machine gun is a small 'dimple'. Drill into the each dimple using a 0.5 mm diameter drill.

Cut a length of 0.4 mm diameter micro-tube (Albion Alloy's MBT04) then flatten it.

With the two guns temporarily positioned correctly, place the flattened tube across the muzzles and mark the position of the two drilled holes.

Bend the flattened tube at the marked positions to form a right angle at each end of the tube.

Locate the tube into the gun holes.

Use a 'spare' ring site or bend soft wire around a suitable mandrel (drill shank) to for the ring sight.

Attach the ring site to the centre of the support bar.

Remove the sight bar from the guns and the guns from the decking panel.

NOTE: The gun sight assembly will be fitted to the guns later in this build.

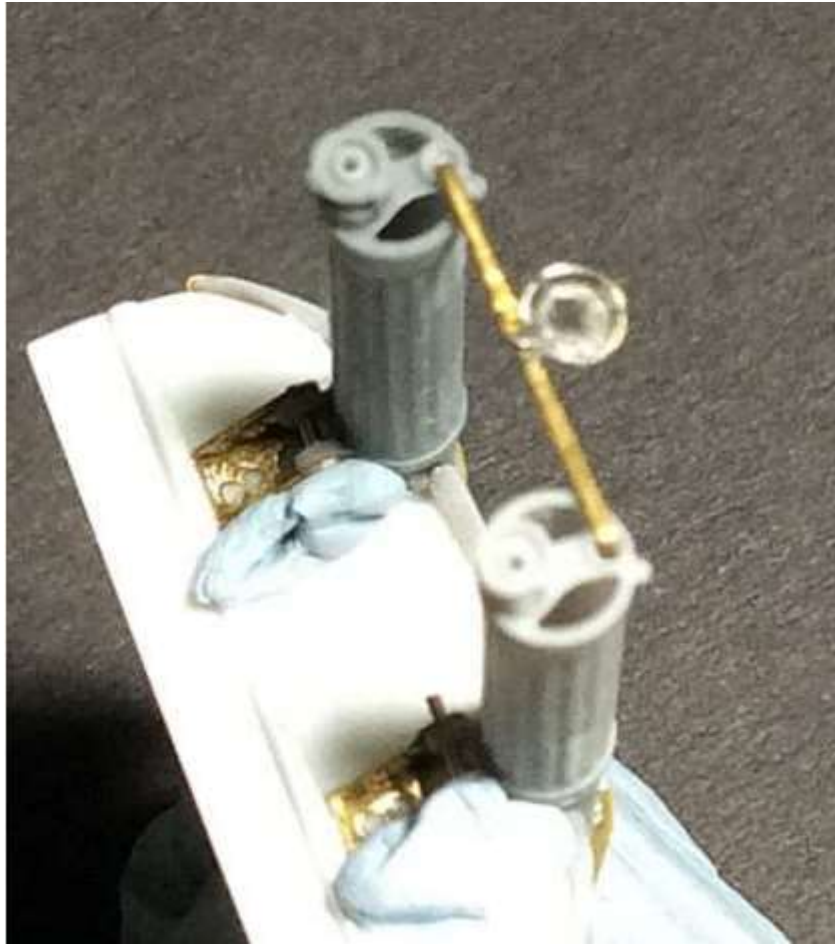

20. Oil cooler drain valve:

The forward, lower louvered fuselage panel has on its centre line the engine oil cooler. Although the kit supplied panel has the oil cooler detailed, it does not have the cooler drain valve included.

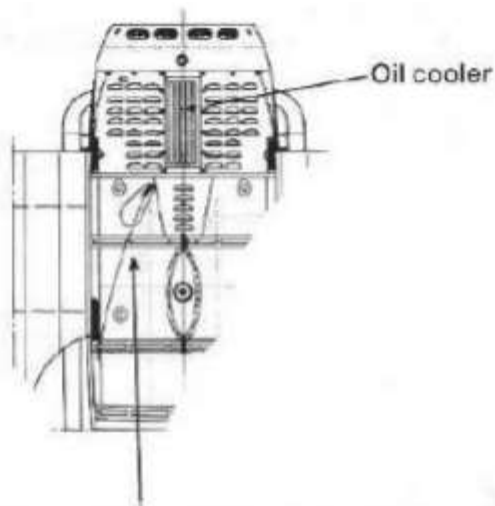

Rip panel and cable to cockpit for emergency fuel jettison

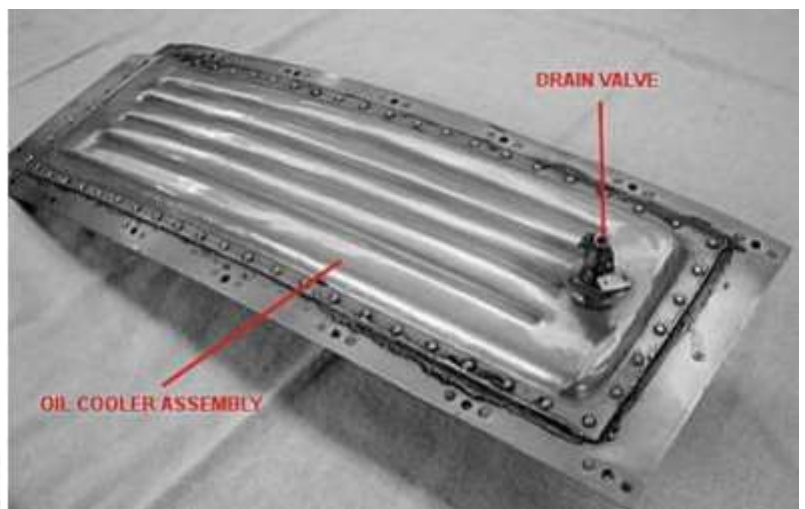

At the centre, rear of the panel, drill a hole of 0.5 mm diameter.

Cut a short length of 0.5 mm diameter micro-tube (Albion Alloy's MBT05).

Slide the tube onto a length of 0.3 mm diameter micro-tube (Albion Alloy's NST03).

Secure the two together using thin CA adhesive.

'Roll' cut the 0.3 mm tube to leave a small stub protruding from the 0.5 mm tube.
Secure the 0.5 mm tube into the drilled hole using thin CA adhesive.

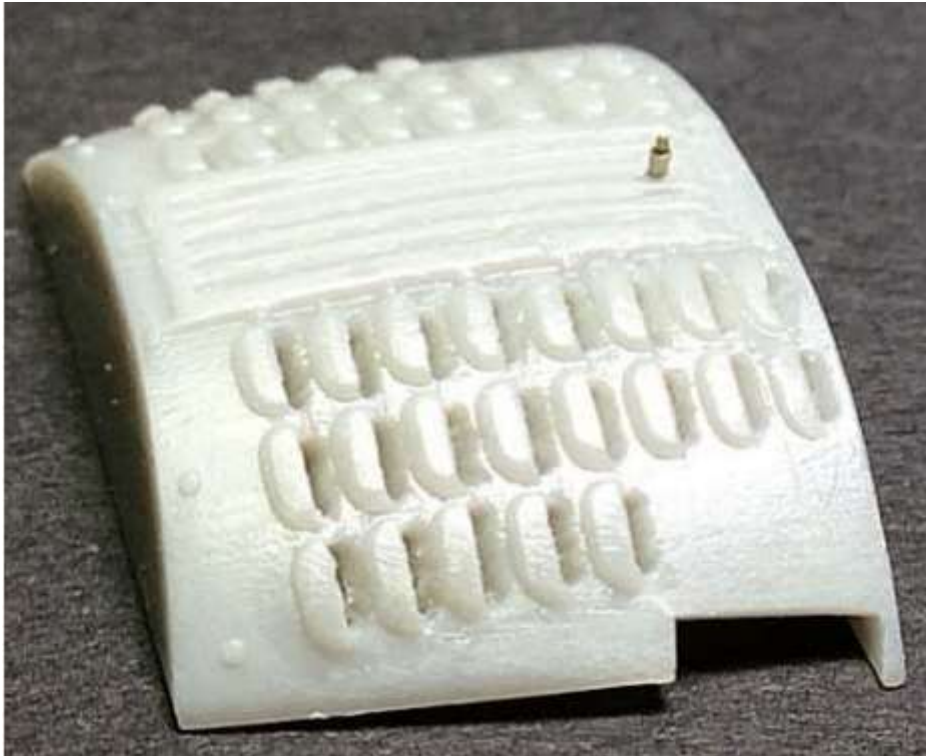

21. Undercarriage struts:

The two kit supplied undercarriage struts are molded as single pieces. However in this particular kit, both struts had ejector pin marks from the molds and also had stress lines causing distortion along each leg. Although the ejector pin marks can be easily sanded out, the stress lines would have weakened the struts and attempts to straighten out the distortion would further weaken the plastic. Therefore I decided to replicate the two undercarriage struts out of plastic card.

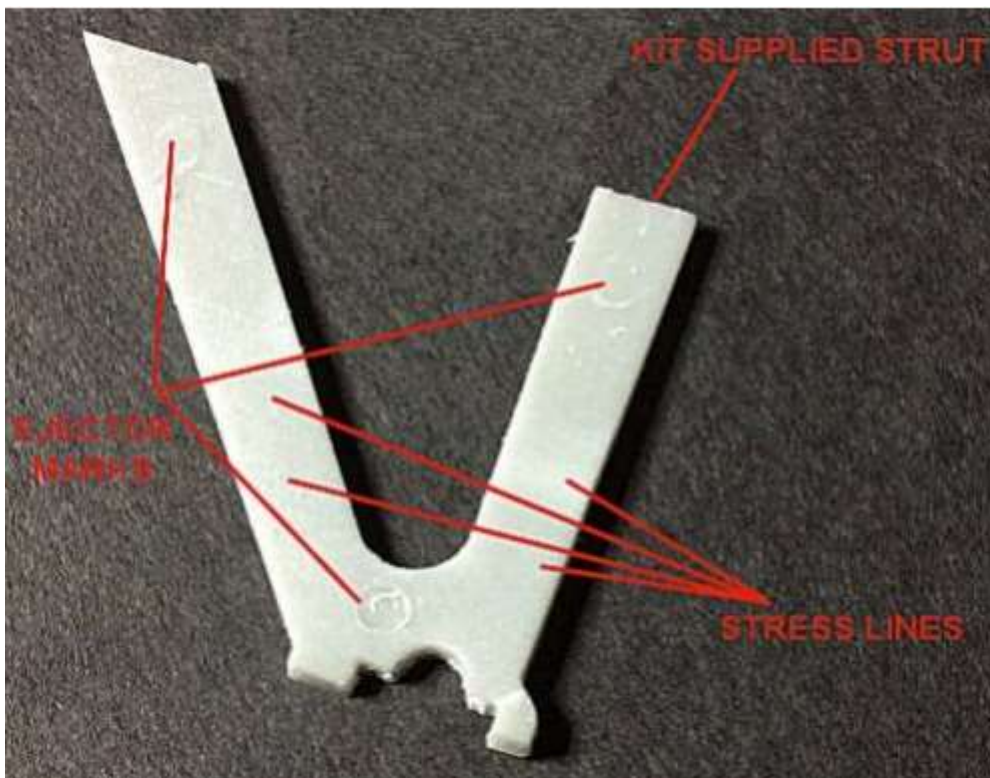

Trace the outline of each undercarriage leg onto 1.0 mm thick plastic card. The kit parts are 1.2 mm thick but I think are slightly over scale.

Using sharp scissors and scalpel blades, cut out the undercarriage strut shapes.

Using a combination of flat, round and half-round needle files, finish the strut out lines.

The kit parts have at the top of each undercarriage leg, on the outer face, premolded attachment brackets. These can easily be replicated by cutting out the shapes from 0.2 mm thick plastic card and cementing them onto the relevant strut.

File or sand of the edges of the struts to form a slightly rounded profile.

To strengthen the strut to fuselage joints, I drilled holes of 0.5 mm diameter into the fuselage strut recesses and also into the ends of each strut. Short lengths of 0.5 mm diameter Brass tube (Albion Alloys MBT05) were inserted into the struts holes and secured using thin CA adhesive (not shown below).

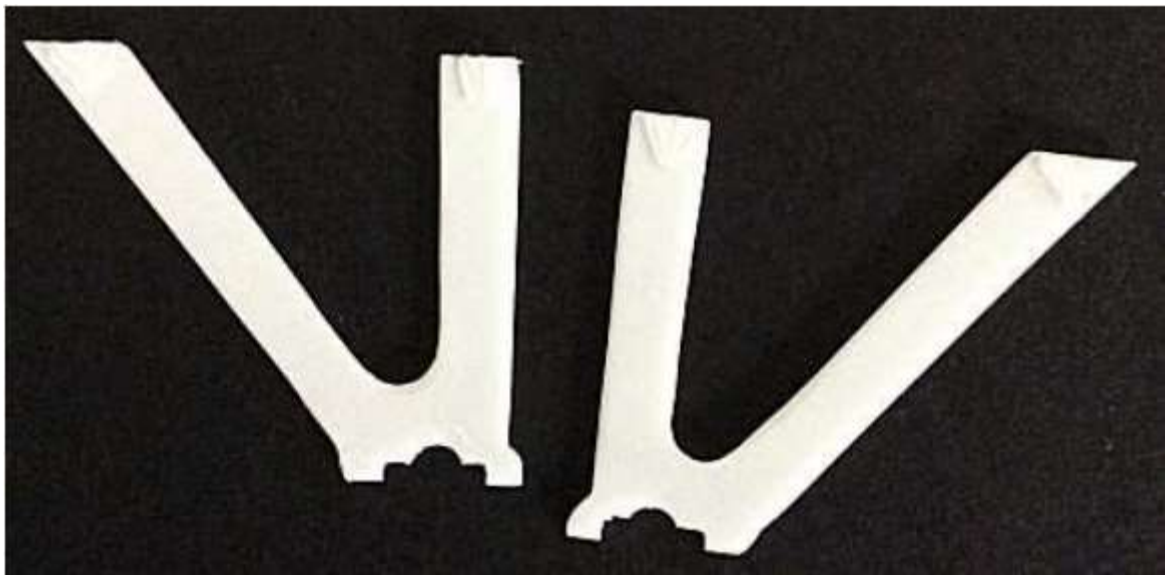

22. Pipes - Upper wing to fuselage:

The fuel feed tank and radiator coolant tanks were located inside the centre section of the upper wing. Four pipes connected these tanks to the engine and cockpit. Three pipes were situated in a row inline with the fuselage entered the rear of the engine bay, just inboard of the left machine gun. The fourth pipe was connected to the underside of the wing and turned through 90 degrees to join to the third (rear) pipe. Although not confirmed, as far as I can ascertain the pipes were:

Forward pipe - fuel supply from the wing fuel tanks to the engine carburettor.

Second pipe - coolant supply from the wing coolant tank to the radiator header tank.

Third and Fourth pipes - fuel supply from the ventral fuel tank up to the wing fuel tank.

As these pipes were exposed to the elements, they were protected by a fabric 'fairing', which was wrapped around the three primary pipes and stitched closed at the trailing edge. This linen covering spanned between the underside of the upper wing to the fuselage decking panel. Some SPADs had this covering removed, presumably as it obstructed the pilot's view. However, this particular aircraft of Frank Luke Jnr appears to have had the covering fitted.

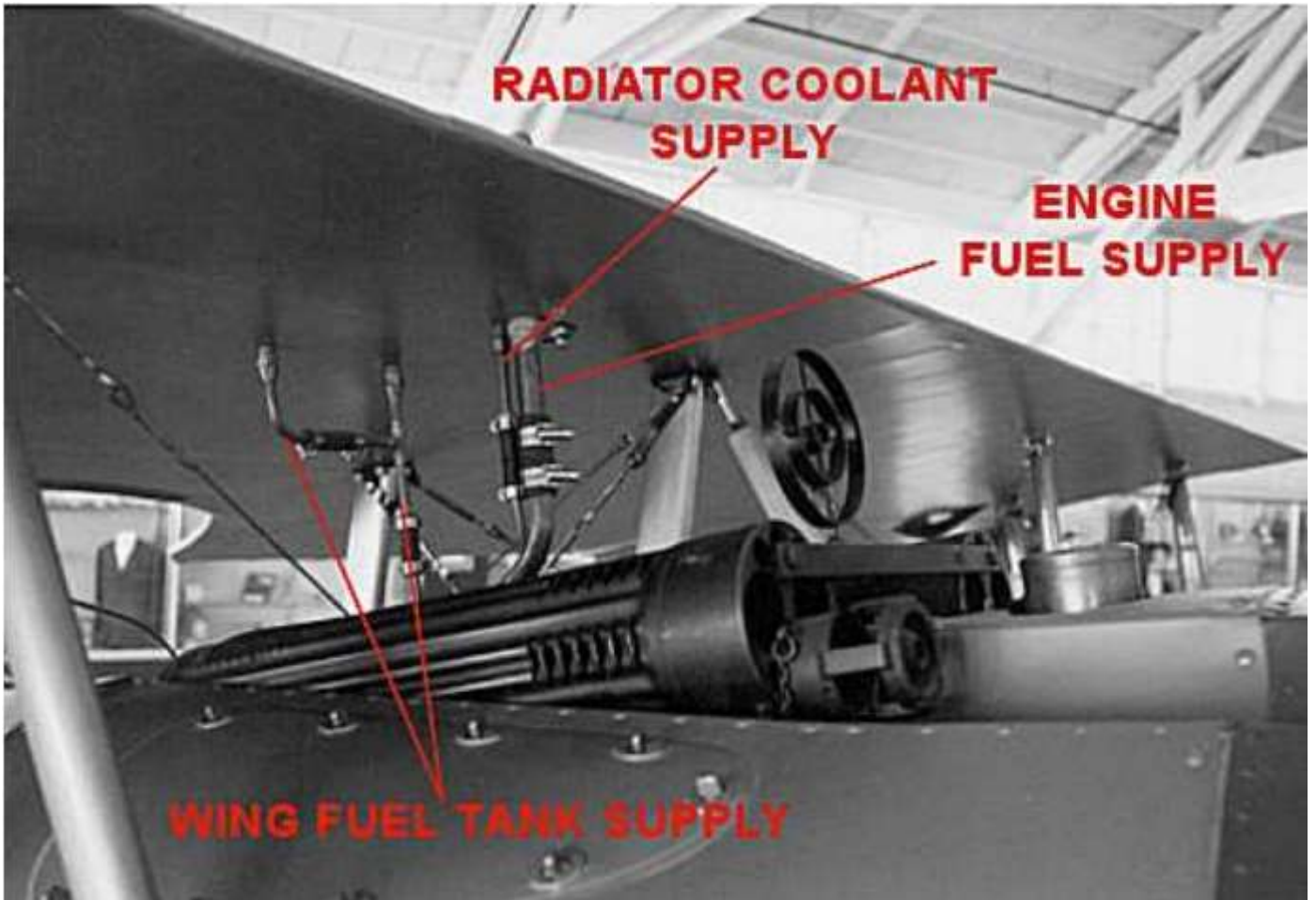

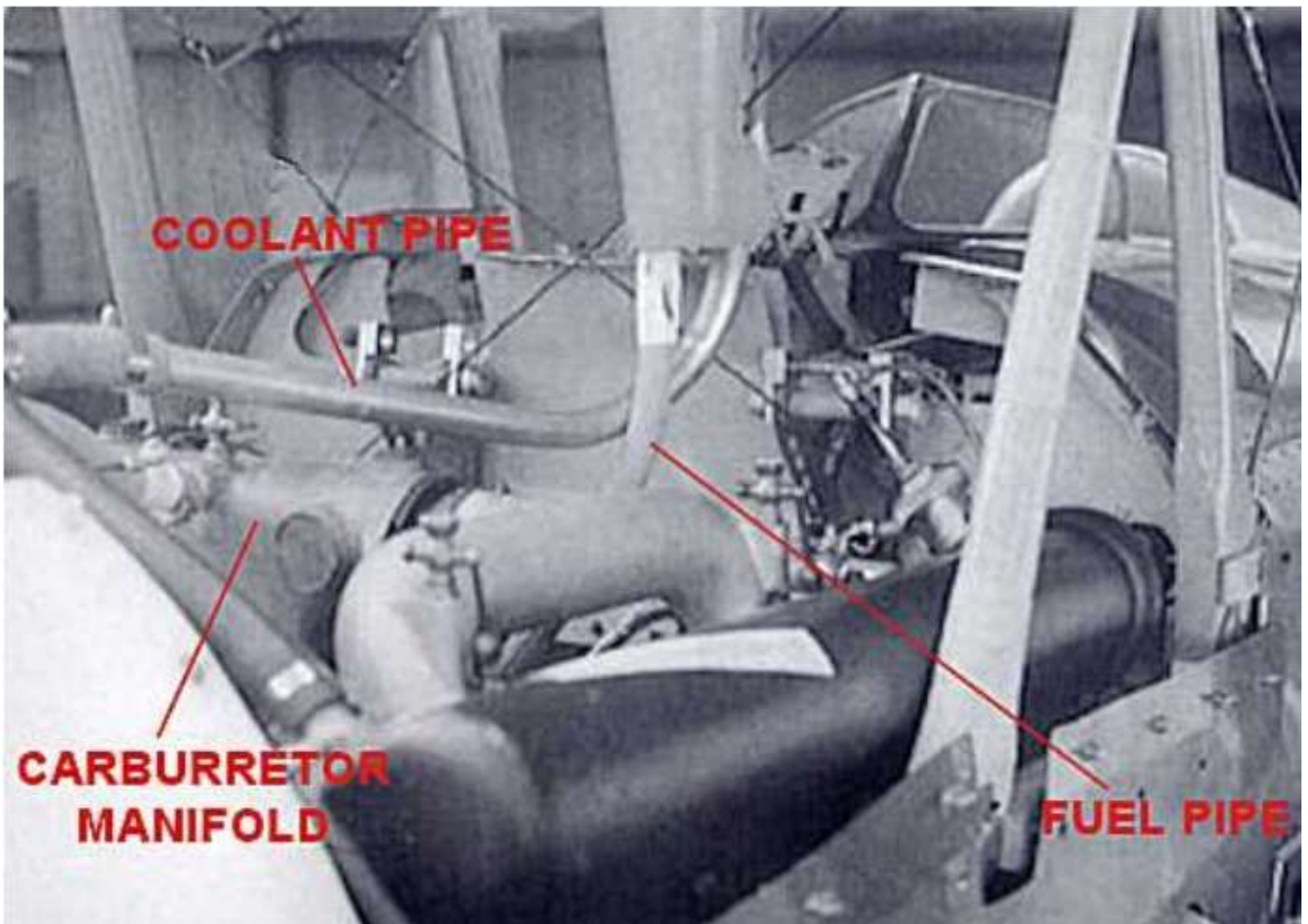

The kit supplies a basic 'fairing' with two pipes/location pins on the top and bottom faces. This will suffice to 'cover' the three in-line pipes, but the kit makes no provision for the fourth pipe, which drops from the wing underside, through 90 degrees and into the fairing to connect to the rear pipe there. In addition there are twin bracing wires that are connected to the top of the forward cabane struts and cross each other as they enter the centre aperture of the decking panel. The left bracing wire passes through a slot in the pipes fairing.

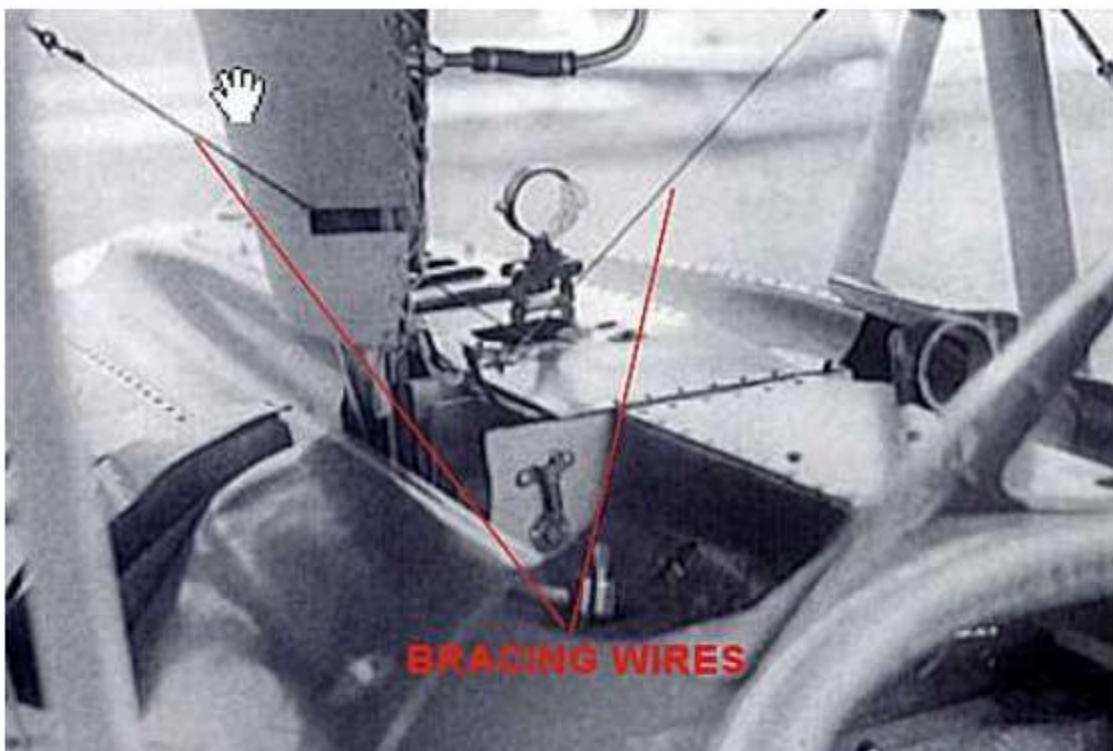

On the kit supplied fairing, cut away the top two location rods and the bottom two 'pipes'.

To strengthen the fairings attachment to the underside of the upper wing, drill two holes of 0.5 mm diameter in the fairing top, at the positions of the cut away rods.

Insert two short lengths of Albion Alloys 0.5 mm micro-tube (MBT05) into these holes and secure with thin CA adhesive.

At the required angle drill three holes, close in a row, through the fairing using a 0.6 mm diameter drill. Then drill through the holes at an angle to create the slot required for the cross-bracing wires.

NOTE: When attaching the fairing ensure the sloping edge is at the rear. Also that the slot through the fairing is angled down from the outer face so as to finish lower on the inner face.

Secure the fairing in position on the underside of the upper wing using first thin CA adhesive and when set, back up the joint with plastic cement (e.g. Tamiya thin).

Cut a very short length of Albion Alloys 0.6 mm diameter micro-tube (MBT06) (to represent the rubber pipe joint) and also a suitable length of 0.4 mm micro-tube (MBT04).

Slide the 0.6 mm tube onto the 0.4 mm tube.

Drill a 0.5 mm diameter hole in the underside of the upper wing, inboard from the fairing and towards the rear of the fairing.

Use a toothpick to bend the 0.4 mm tube to 90 degrees.

Test fit the tube in the drilled hole and cut/file/sand away the tube ends until the bent pipe sits correctly.

Secure the bent pipe into the hole and against the fairing and the 0.6 mm tube on the 0.4 mm tube, using thin CA adhesive.

NOTE: The pipes from the fairing into the engine bay and cockpit will be attached later in this build.

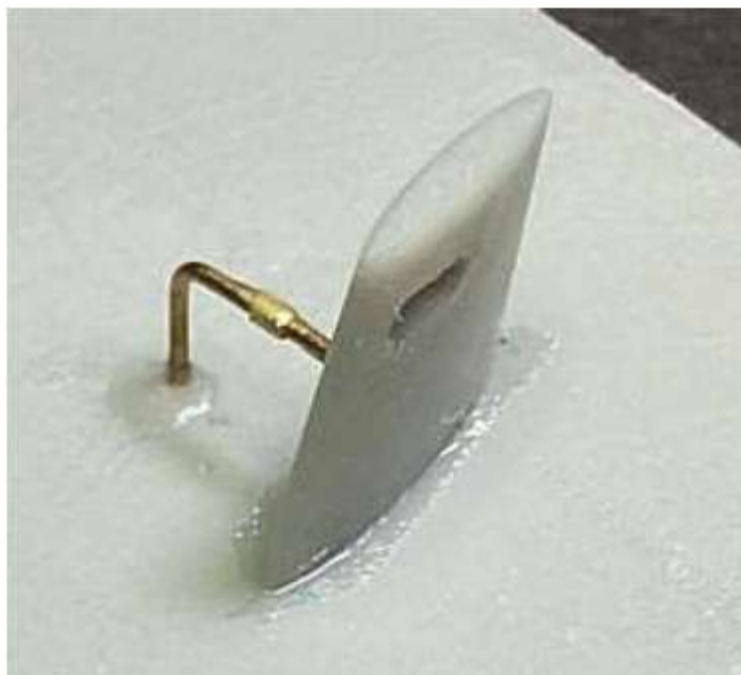

23. Flying wire covers:

The SPAD XIII had twin flying and landing wires, which were routed between the outer wing struts to the lower wing roots and top of the cabane struts. British aircraft also employed twin wires, but a side effect of having two wires so close to each other was that the airflow over and through the wires became disrupted, causing drag and vibration. Different methods were employed to overcome these side effects. On the Spad, the twin flying wires were covered to effectively create a single, flat surface.

Unfortunately these covers were not fitted to the model as basically, I forgot about them and realised my mistake too late in the build.

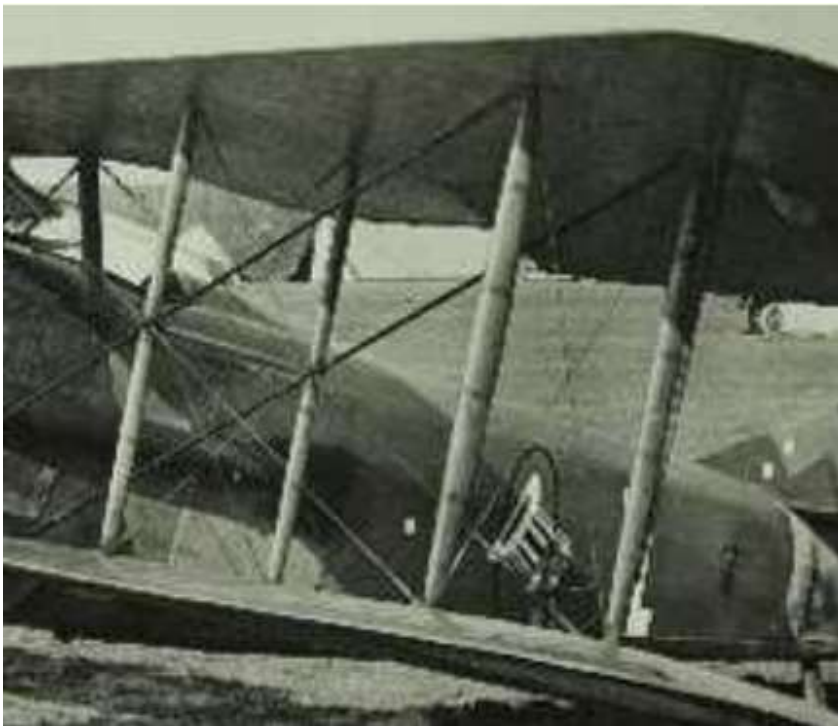

24. Cockpit Instruments:

The cockpit instruments are covered in Part 4 of this build log.

25. Engine exhaust pipes

The engine exhaust pipes on the Spad XIII were secured to the fuselage sides by a single bracket towards the rear of each pipe. In addition the exhaust outlet at the tail of each pipe was perforated to allow to exhaust gases to vent to atmosphere in a controlled fashion.



The exhaust pipes supplied with the kit have solid tail pipes and the two support brackets are also solid pieces. To represent the tail pipes and support brackets I did the following.

Tail pipes:

Cut away the location stubs from the front and rear exhaust 'stub' pipes (not required). Drill three holes across the tail pipe serrations (but not all the way through) using a 0.3 mm diameter drill. A drill of 1.0 mm diameter was used to create a hole part way through the inner side of each pipe, opposite the existing hole in the fuselage sides (for kit item C5). This hole will be used to locate the exhaust pipe onto its support bracket.

Support brackets:

A length of 0.4 mm diameter brass tube (Albion Alloys MBT04) was annealed (softened) over a flame then bent to match the shape of the kit supplied items (C5), but with enough tube to be able to penetrate the fuselage. The exhaust pipes were positioned against the fuselage sides and the 'legs' of each support bracket marked on the fuselage sides with a soft pencil. A drill of 0.5 mm diameter was used to drill through the fuselage sides for mounting the support brackets.



26. Breather cap:

The breather cap fitted outboard and to the rear of the pilot's right shoulder. The kit item (C9) is molded as a solid piece, whereas the actual cap had breather holes around the top of the cap.

To replicate this cap I cut away the stem and drilled a 0.7 mm diameter hole up into the cap body. Into this I secured a short length of 0.6 mm micro-tube (MBT06) using CA adhesive. The cap was brush painted with 'Mr. Metal Colour' Stainless Steel (213).



PART 2 - WOOD EFFECTS (General)

A basic technique:

Parts of the model that are supposed to be made of wood can prove to be a challenge to replicate a wood finish to the part. Some after market companies produce accurate wood decals, which can be used to cover larger areas, such as cockpit decking and fuselage panels. However, decals can't easily be used to create realistic wood finish to smaller items or parts that don't lend themselves to having decals applied. To do this requires brush painting, using such as acrylic or oil paints, which can be enhanced with various washes or filters.

The first thing to do is to ensure the model parts are cleaned, normally with warm water with washing up fluid and something like an old tooth brush. Once cleaned and thoroughly dried, the primer coat can be applied. I use Tamiya Aerosol Light Grey (Fine) or White (Fine) acrylic primer. Once the primer is dry, you can start applying the wood effect to the applicable cockpit items, such the cockpit framework, decking, seat supports, rudder bar, instrument panel and of course, the wing struts. With practice, this method can also be used on fuselage panels and propellers.

To start, apply a suitable base colour. For most painting I use an airbrush and only resort to brush painting when dealing with small items, when I add a few drops of 'Mr. Colour Levelling Thinner', which aids brush painting. For most wood effect, I use Tamiya Wooden Deck Tan (XF78) or Dark Yellow (XF60), suitably thinned with Tamiya Thinners (X20A). Allow this base coat to fully dry (if you can't smell the paint, then it's dry).

Example of base coat using Tamiya Wooden Deck Tan (XF78).

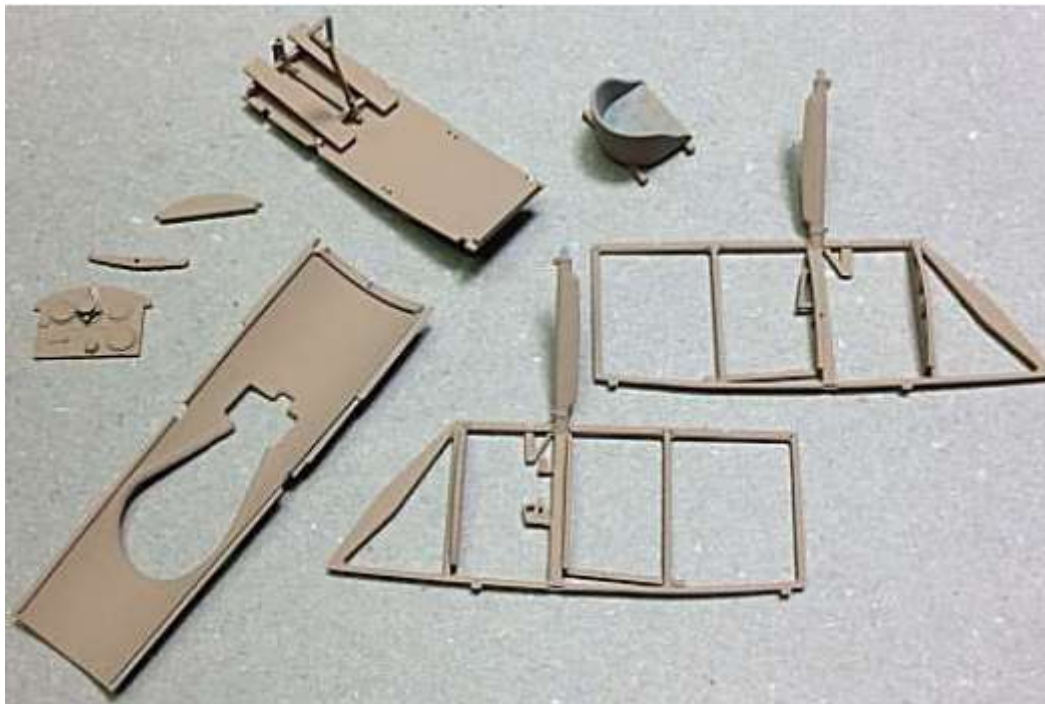

For the next step I use 'DecoArt Crafters Acrylic' (water based) oil paints, either Burnt Umber or Burnt Sienna. These are similar to standard acrylic oil paints, but are water based instead of oil based. This paint is not as thick as oil based paint and is more creamy, so can be brushed and controlled more easily. Also, as it is water based, it's easy to clean your brushes, and if really necessary, can be thinned slightly with water. In addition, the paints dry as quickly as normal acrylic paints, avoiding the disadvantage of using true oil paints, which can take days to fully dry.

Place a small amount of the oil paint onto a non-absorbent surface and using a suitable oil paint brush (I use a slightly curved brush), wipe a small amount of the paint onto the brush. For larger areas, such as decking or panels etc I use a small piece of fine sponge to apply the paint.

Apply the paint to the applicable item, using light strokes and in the required direction. Apply the paint along struts and across instrument panels and other smaller items. This gives variation to the wood effect and for the wing struts, is correct for the direction of the wood grain. If you apply too much paint, just brush or sponge it off immediately before it dries. Although the paint is water based, don't try to thin any applied paint with water as it will lift the paint, which builds up into clumps. If required, a second light coat can be applied. Always wait until a first coat has fully dried before applying a second coat, otherwise the first coat will 'drag' and lift from the surface.

Once painting is complete, clean the brush in water.

Below is an example of the Burnt Sienna oil paint applied to a cockpit side frame.



Once the oil paint layers have dried, the final top coats can be applied to give the final effect of varnished wood.

Tamiya have 'Clear' coloured Acrylic paints, which are intended to be mixed with either Flat Clear (XF86), Semi-Gloss Clear (X35) or Clear (X22), to give the required finish but with a tint of the added 'Clear' colour. I use the Clear Yellow (X24) or Clear Orange (X26) to add a varnished tint to the clear coat. However, I don't use the Tamiya Clear, but instead use Alclad Light Sheen (ALC-311). Although it's a lacquer, I've found that it will accept Tamiya 'Clear' coloured Acrylics without any separation, which can happen with other paints. The Alclad lacquers dry fast and provide a good sealing layer over the painted surfaces. When using Alclad sealing coats, the golden rule is to allow the various painted surfaces to dry fully before applying Alclad lacquers.

I add a few drops of Clear Yellow (X24) into the Alclad Light Sheen (ALC-311) and thoroughly mixed it. Only add small amounts to the Alclad in order to control the amount of tint you desire. I increased my airbrush air pressure to around 20 psi to airbrush the sealing coats over the various cockpit items. The first coat usually dries to a more matte finish, which I assume is due to being sprayed onto the oil paint, rather than onto straight acrylic paint. Once this first coat has dried, I airbrushed several coats of just Alclad Light Sheen (ALC-311), which added not only more sealing coats, but more importantly gave the desired semi-gloss 'varnished' finish I was after.

Below is an example of the applied Alclad lacquer/X24 mix on a propeller.



NOTE: Once you are confident using this method of replicating wood finishes, you can vary both the colour of the acrylic base coat and tinting of the sealing coat, to replicate other types of wood used in aircraft construction.

Once the lacquer coats are thoroughly dry, any detail painting, decals or final weathering can be applied to the parts, as required, prior to fitting them to the model.

PART 3 - WEATHERING (General)

Flory Model clay washes: These washes come in various shades and consist of a very fine clay pigment. They are brushed over the surface to be weathered and dry in around 30 minutes. When dry, use either a piece of good, absorbent kitchen roll or a brush used for oil paint (as the bristles are harder than normal painting brushes) to remove as much of the clay wash as you need to achieve the desired effect. Once dampened, the dried clay is re-activated and the clay wash can be removed or worked as required.

First I seal the surface with airbrushed Alclad Klear Light Sheen (ALC-311), which dries quickly. A gloss coat tends to stop the clay wash 'gripping' the surface when it is applied and it can run off or just puddle. A matte coat can cause the clay wash to 'grip' too much, making it very difficult to remove or even to wash it off completely.

To apply the clay wash is just a matter of brushing all over the surface to be weathered. It doesn't matter really how much is applied and it can be left on for any period of time, as it is easily removed without any effect on the surface underneath. The washes I tend to use are Flory Clay Wash 'Grime' and 'Dark Dirt' .

I use an oil brush to brush off the clay wash, but for smearing effects, an only very slightly damp brush or absorbent paper can be used, but even then I dab them onto a dry piece of the paper. That's how 'damp' it needs to be. Any wetter and you'll find that you are removing too much of the clay wash. If that happens you would have to re-apply the wash and start again.

That said, if you not happy with the final effect, you can easily remove the clay wash by brushing with a wet brush or even airbrush water over the surface. Dry off the surfaces washed and then re-apply the clay wash and try again until you are satisfied.

The technique is to brush over the surface to re-activate the clay wash and at the same time, to smear it over areas that had no clay wash. It'll dry more or less straight away.

Then I'll very lightly stiff brush and/or use a piece of damp absorbent paper or brush to remove as much as I want until I get the desired effect. If I remove too much I just reapply clay wash to that area and repeat the removal procedure.

Once finished, just run the brush under a tap to rinse out any residual clay pigments.

Finally I seal the surface with airbrushed Alclad Klear Light Sheen (ALC-311), which will seal in the applied clay wash.

NOTE: Flory washes can be mixed to create other colour blends.



Chipping effects:

I wanted to give the effect of chipped and weathered paint/varnish to the metal engine cowl and forward fuselage panels. To achieve this effect, I first primed the areas with Tamiya Fine Surface primer (Grey) then airbrushed Tamiya Aluminium (XF16). Once dry I airbrushed AK Interactive Medium Chipping fluid (or Vallejo chipping fluid) and when dry, top coated with Tamiya Ocean Grey (XF82). Once fully dry I moistened the top coat with water, which softens the paint. Then with a cut down (stiff) brush and wood cocktail stick, gently teased off the top coat paint. Be careful when doing this as 'too much chipping' can't really be covered up. In that event you wet the top coat and remove it all with an old toothbrush or similar and then when dry, respray the top coat and try again. Once the desired effect was achieved, I sealed the surfaces with an airbrushed coat of Alclad Light Sheen (ALC-311).



Tamiya Weathering Master sets: Each of these Tamiya produced weathering sets contain three 'tablets' of different colours and an applicator, which has a brush on one end and a sponge on the other. The tablets have a wax look and feel and can be applied onto painted surfaces to reproduce various finishes.



Pigments: Pigments, such as those produced by 'Flory Models' or 'Humbrol' are effectively very fine 'dusts', which can be applied to a model to re-create dust, dirt, stains etc. They can be applied by dry brushing or mixed with other mediums to create paintable solutions.



Washes: Washes can be applied to either enhance panel lines etc or to add a 'filter' of colour onto a painted surface. They can be purchased ready made from various manufacturers or can be 'home made' using such as oil paints with a suitable thinning agent. I use 'AK Interactive' products.



Oil paint: A technique used more frequently now is oil paint 'dot and drag'. Basically an oil paint of the desired colour is placed onto a piece of cardboard, which over a hour or so, soaks out the oil in the paint, leaving a drier pigment. The pigment is dotted onto the painted surface where desired then dragged with a brush previously wetted with a good enamel thinners and wiped dry. Softly dragging the brush through the pigment thins the pigment and spreads it in a thin layer. The amount of pigment left showing depends on the effect you require. Always keep the brush wiped clean to avoid a build up of pigment and remoisten and wipe dry often. The more you drag, the less pigment is left showing. Blending different coloured pigments can create stains from smoke/gun blast, rain marks/runs, dirt/dust and oil/fuel stains.

A good quality oil paint and thinners are essential to produce a good finish. Some quality oil paints can be too 'gritty' when leached of oil, so I use 'Abteilung 502' oil paints and Tamiya Enamel thinners (X20).



PART 4 - THE COCKPIT AND INTERNAL FUSELAGE.

NOTE: The fuselage halves were heavily modified in Part 1 of this build log. As such, the basic cockpit floor/seat assembly is already fitted in the left fuselage half and the added cross bars and 'linen' storage are fitted to the right fuselage half. As such the cockpit and fuselage internals will be covered together in this chapter.

General: The models cockpit lacks the following components fitted to the actual aircraft:

1. Cockpit instruments.
2. Pilot seat cushion.
3. Vent pipe from oil tank to rear of engine.
4. Oil supply/return pipes to engine.
5. Fuel supply pipe from ventral tank.
6. Fuselage and engine bay cross brace rigging.
7. Instrument pipes.
8. Flying control cables (rudder, aileron and elevator).
9. Mallet (gun jams).
10. T-handle for fuel rip panel.
- 11 Rudder bar foot straps.
12. Control column mounted gun firing cables.
13. Pilot seat straps.

NOTE: Refer to the following photographs for details of the various cockpit items.

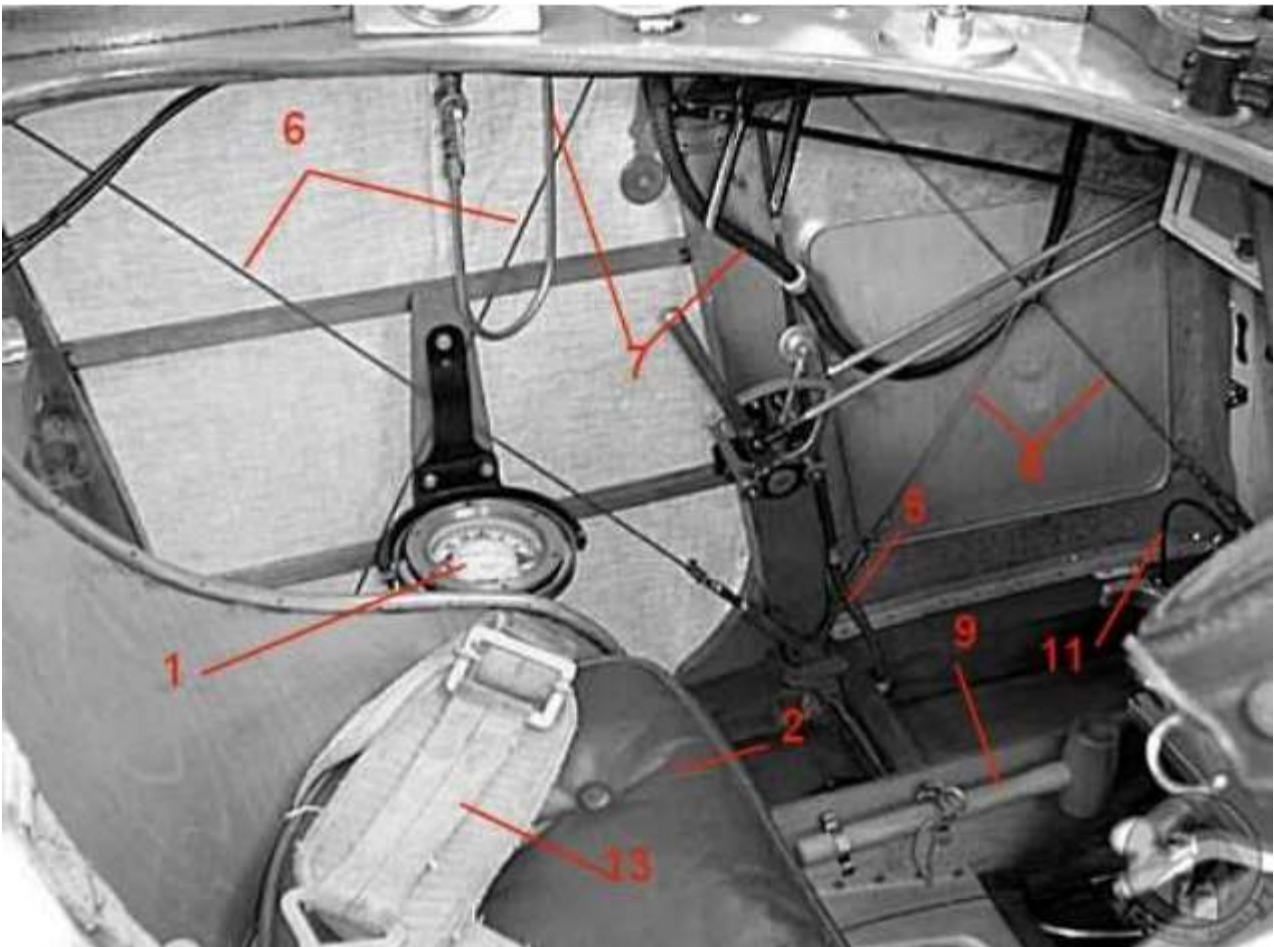

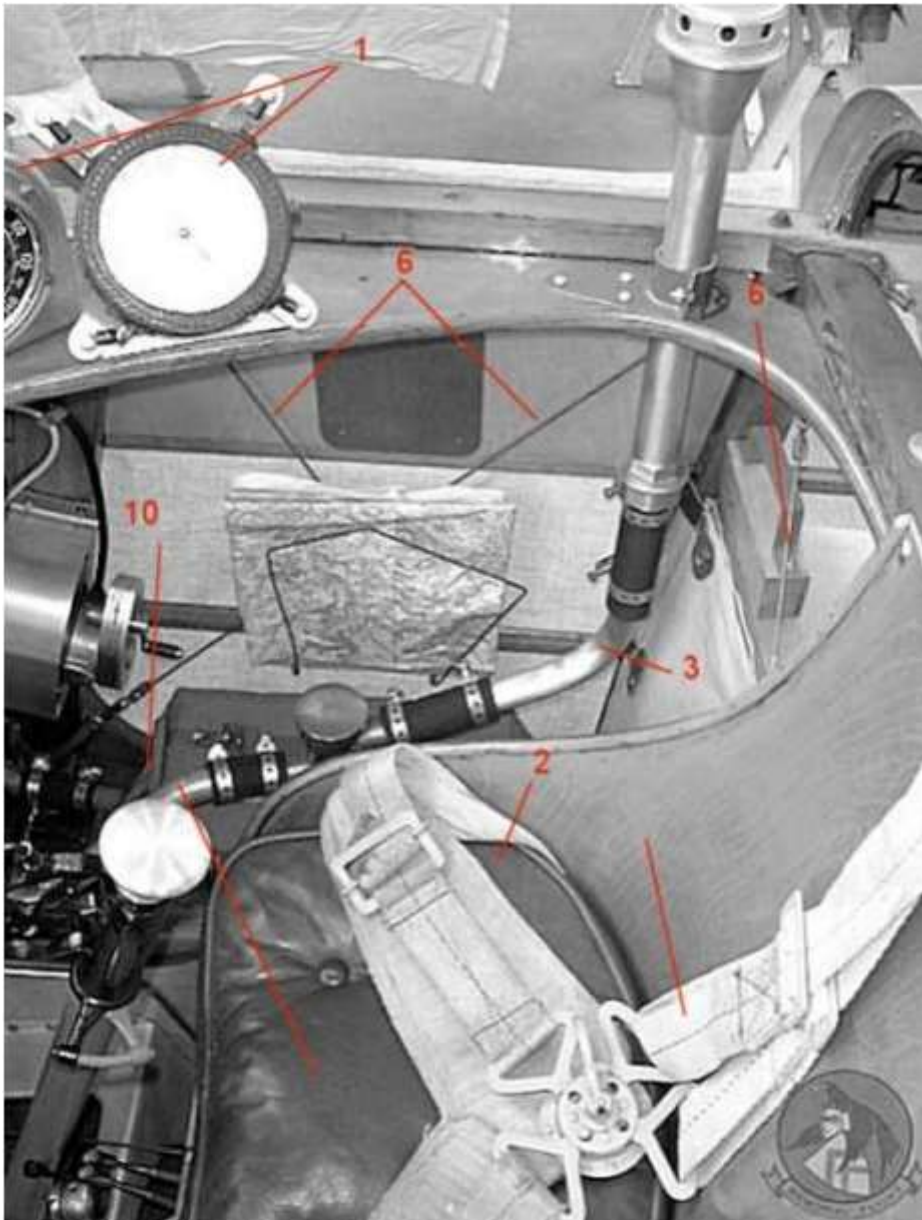
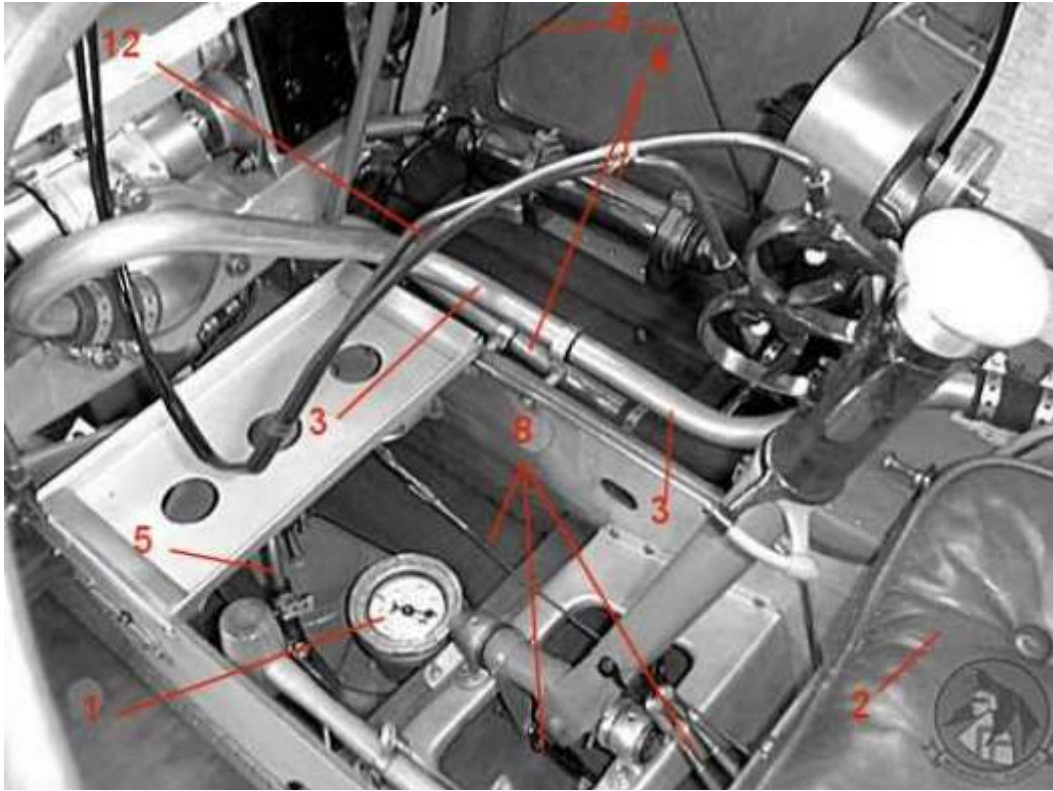

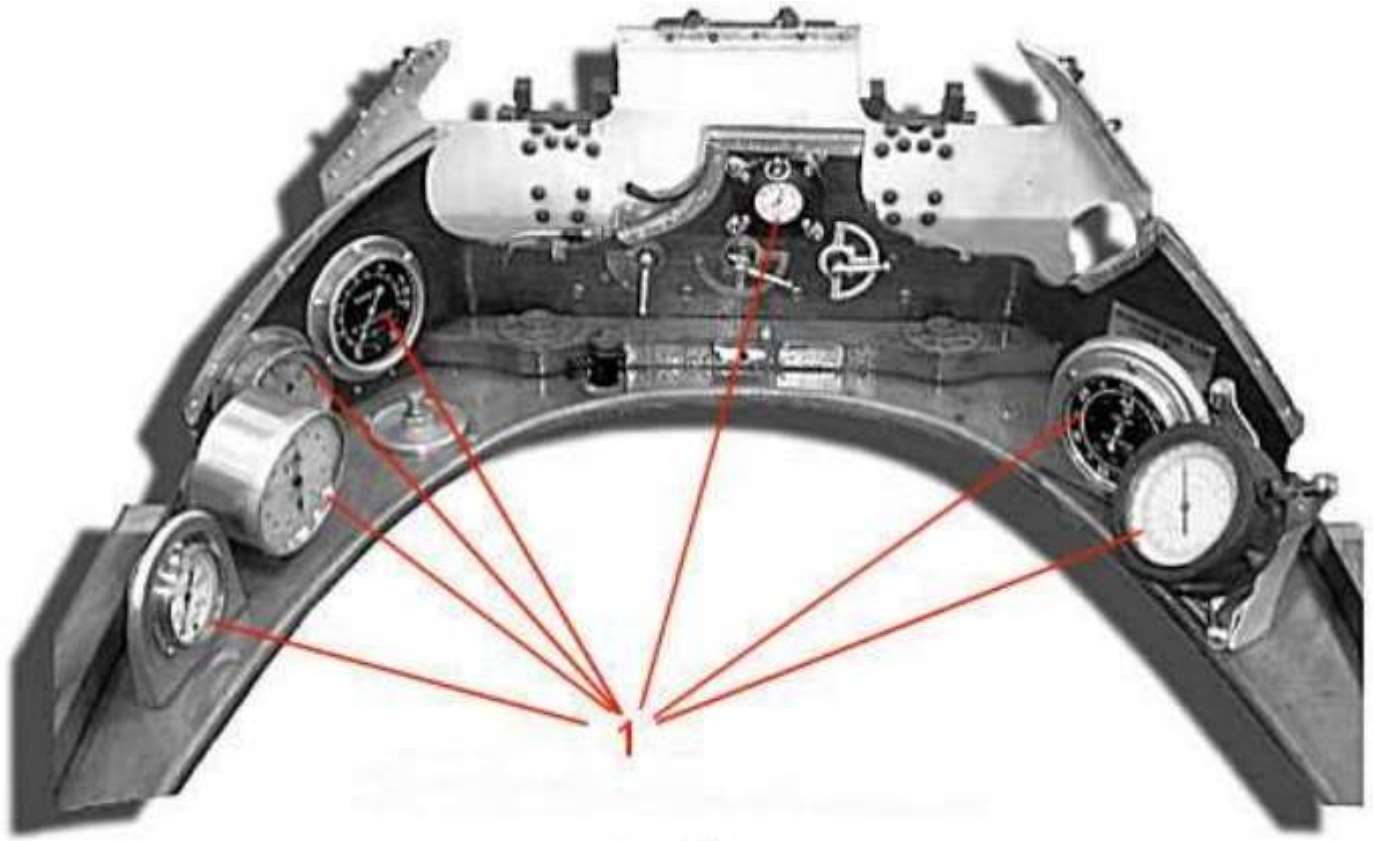

1. **Cockpit instruments:** The kit supplies only four instruments, three on the cockpit coaming and the compass on the left side of the fuselage. The actual aircraft appears to have more on the cockpit coaming as there were six instruments, four on the left side and two on the right. Also a clock was fitted in the centre of the forward panel. On the lower left fuselage, adjacent to the pilots seat, was the compass. These instruments would typically be: An airspeed indicator, compass, altimeter, tachometer (engine revs), temperature gauge (engine cooling), fuel contents gauge, fuel pressure gauge, air pressure gauge (fuel tank), clock.

To add the three extra gauges and the clock to the cockpit coaming and to replace the compass:

Four slices of waste plastic sprue were cut from appropriate sized diameters - two thin, one medium thickness and one thicker - to represent the missing instruments from the model kit.

Cement the two thin slices onto the front face of the left coaming beneath the rear decking panel (modified kit item B6).

Cement the medium thick slice onto the coaming panel (kit item C18) where the kit item C11 instrument should be located.

Cement the medium slice onto kit item C12 (supplied but not used) then at the bottom rear of item C12, cement a short strip of plastic rod or similar to support the instrument . Cement item C12 on the coaming panel, next to kit item C13 and on the pilot side.



GENERAL - INTERNAL FUSELAGE:

I used Tamiya Fine Grey primer (aerosol) to prime:

The centre of the lower wing (under the cockpit floor)

The internal surfaces of the fuselage halves

The cockpit coaming panel (kit item C18)

The underside of the modified rear decking panel (kit item B6)

Once dry, I brush painted Mr. Metal Colour Stainless Steel (MC213):

Forward, from the front of the centre side strut on each fuselage half

Centre section of the lower wing.

Inner surface of the louvered engine panel (kit item B12)

Oil tank (at right of pilot's seat).

The fuselage internal surfaces, including the 'linen' storage on the right half, were brush painted with Tamiya Buff (XF57) and once dry was given a light thinned coat of Tamiya Clear Yellow (X24), to create the effect of Clear Doped Linen (CDL).

NOTE: As with most colouring for World War One aircraft, it's debatable as to the exact colours and tints. New aircraft colours would differ from those that have 'seen service' and age and the ambient conditions would have altered these colours. In addition, the chemical mixture of the various dopes changed throughout the war, due to short supplies of some of the ingredients and the particular aircraft manufacturers take on a particular colour specification. Most colour photographs are of museum aircraft and modern replicas, which may or may not be accurate depictions of the actual colour at the time. The best we as modellers can achieve is what we, as individuals, consider is 'accurate'.

The cockpit floor and seat assembly, the support frame work on both fuselage halves and the cross bars (at the 'linen' storage) were brush painted using Tamiya Wooden Deck Tan (XF78), suitably thinned with Tamiya Thinners (X20A).

Once dry apply 'DecoArt Crafters Acrylic' Burnt Umber (water based oil paint) on those areas painted at 4 above, to create the wood effect. Refer to Part 2 - Wood Effects, for more detailed information).

Once dry all painted surfaces were airbrushed with a sealing coat of Alclad Light Sheen (ALC-311) lacquer, to seal the surfaces in preparation for weathering.

'Flory' clay wash (Grime) was then applied to the non-metal surfaces. The metal surfaces were washed with 'Dark Dirt'. For how to apply 'Flory' clay washes, refer to Part 3 of this build log.

Once completed, I airbrushed a light Alclad sealing coat over the these areas to seal in the clay wash.

To enable the fitting of the tail skid and to ensure the fuselage halves close up fully, it's best to fit the tail skid (kit item C7) into one of the fuselage halves. After priming, the skid was brush painted with Tamiya Red Brown (XF64), Buff (XF57) and Mr. Colour Master Stainless Steel (213).

Ensure any paint is removed from the location points in the fuselage halves before you fit the tail skid. Fit the skid into its location point in one of the fuselage halves and apply cement to that location. Immediately add the opposite fuselage half to close up the fuselage, making sure as you do this that the tail skid is aligned correctly and that it fits into its opposite location point. Leave the fuselage closed up until the adhesive locating the tail skid has fully cured, then remove the other fuselage half. You will now have the tail skid fixed into a fuselage half, knowing it will align correctly when the fuselage is finally closed up.

The magneto starter (kit item C10) and control column were primed then brush painted with Tamiya NATO Black (XF69) and Mr. Colour Master Stainless Steel (213) then cemented to the right fuselage half and the cockpit floor.

The throttle and mixture control (kit item B14) was primed then brush painted with Mr. Colour Master Stainless Steel (213) and Brass (219) then cemented to the left fuselage half.

NOTE: Additional instrument decals and bezels used were from the 'Airscale' Instrument Dial set (AS32 WW1) and the Instrument bezels (PE32 BEZ). Use thin CA or PVA adhesive to attach the bezels and once set, Tamiya Clear (X22) on the decals to represent glass faces.

The kit supplied compass (item C15) was replaced by a spare Wingnut Wings item, which was primed then bush painted with Tamiya NATO Black (XF69), after which a suitable decal and instrument bezel were applied. The compass was then cemented to the left fuselage half.

The cases of the instruments on the cockpit coaming were brush painted with either Mr. Colour Master Stainless Steel (213) or Brass (219), after which suitable decals and instrument bezels were applied.

Before continuing it's best the *test (dry) fit* the fuselage halves together along with the cockpit coaming panel (C18) and rear decking panel (B6). This will reveal any areas of primer or paint that needs to be removed to ensure a good fit for the parts.

2. Pilot seat cushion: The pilot's seat as supplied in the kit, has no seat cushion. To remedy this I created one using 'Milliput' putty, shaping the cushion to the seat and pressing in five indents to represent 'buttons'. Once fully cured the cushion was primed then brush painted using Tamiya (XF64) and Humbrol Leather (62).



3. Vent pipe through oil tank to rear of engine: There is what some suggest is the fuel filler pipe, which is located through the right side of the cockpit adjacent to the pilot's shoulder. This pipe is capped with what could be either a filler cap or a vented cap. The pipe is connected to the oil tank filler pipe on the oil tank (to the right of the pilot's seat) and appears to run forward and across the cockpit floor to connect to the engine between the two magnetos. I believe this pipe could be an engine breather pipe, venting the crankcase through the cap. As a fuel filler pipe it would seem dangerous to be filling a fuel tank from a pipe next to the cockpit. Both upper wing auxiliary fuel tanks have what seems to be filler caps and the sump of the ventral fuel tanks also has a cap (probably for draining the tank).

However the kit supplied items are not representative of the pipe assembly and does not pass through *an aperture* in the cockpit side, as on the actual aircraft.

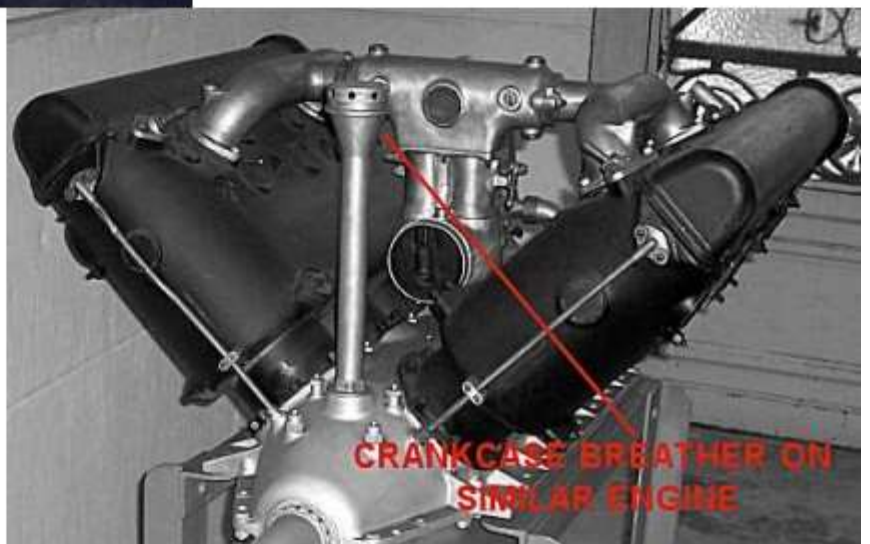
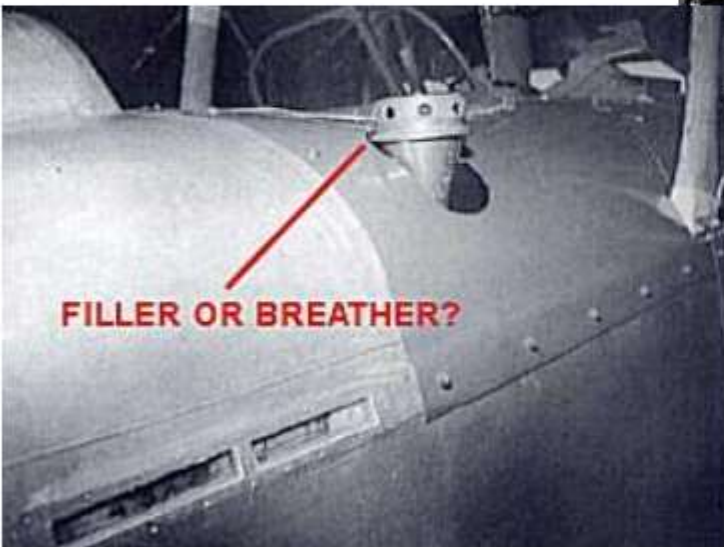
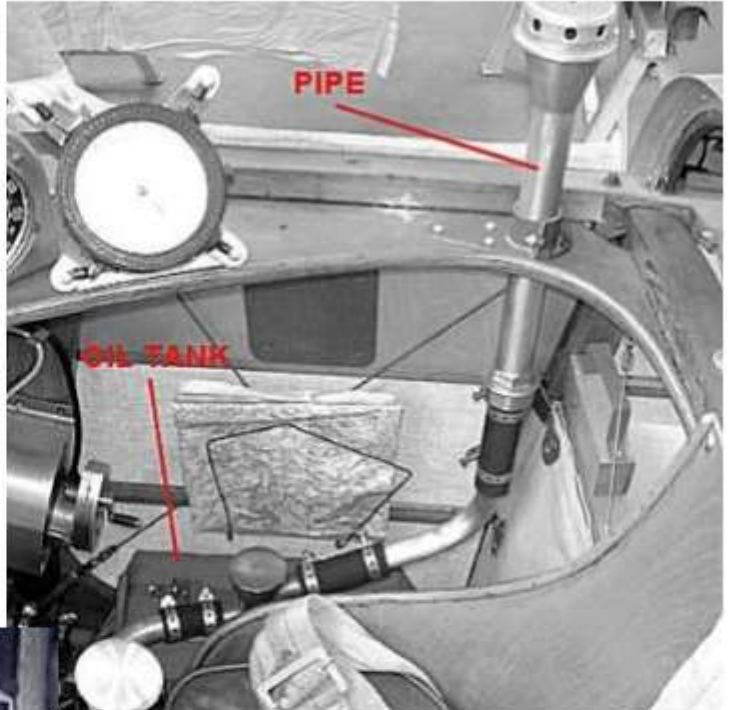
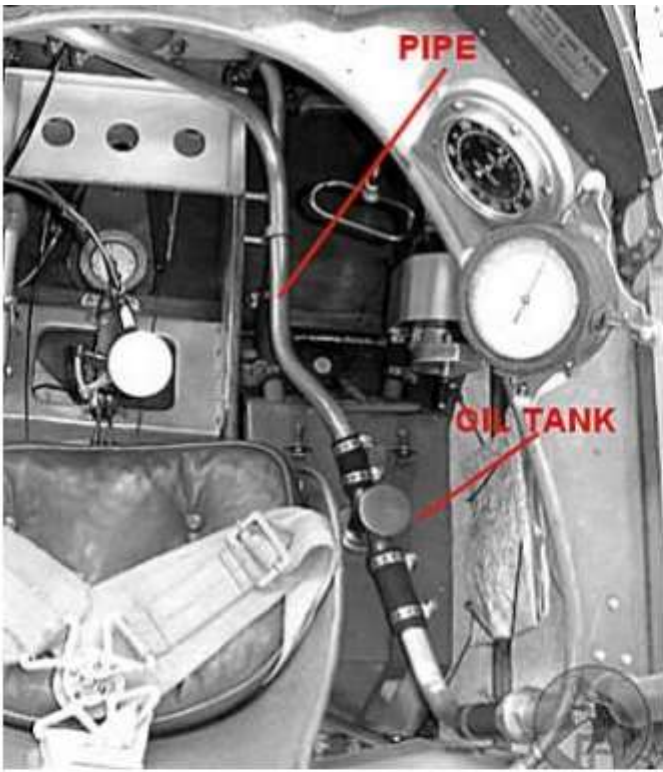

Reference:

Restoration of Spad XIII C.1, Serial No.4377 - <http://memorial.flight.free.fr/indexuk.html>

If the above restoration is correct, then I believe the fuel filling point for the Spad XIII was located at the forward, left corner of the ventral fuel tank, which was fitted below the cockpit floor.

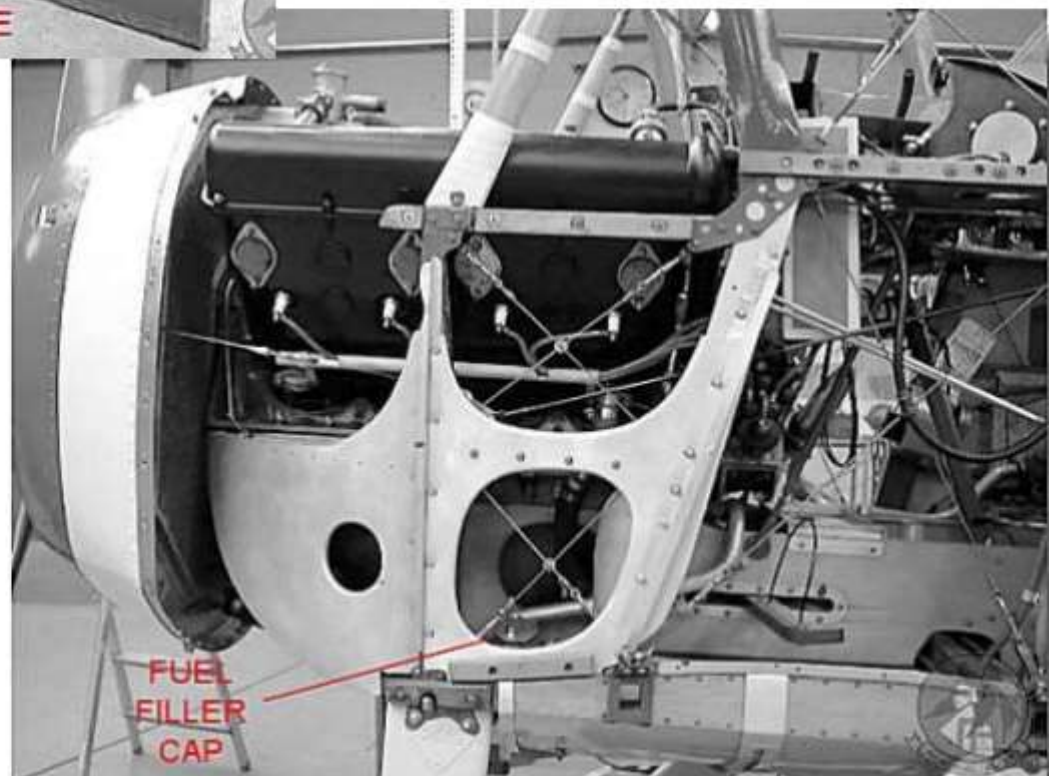
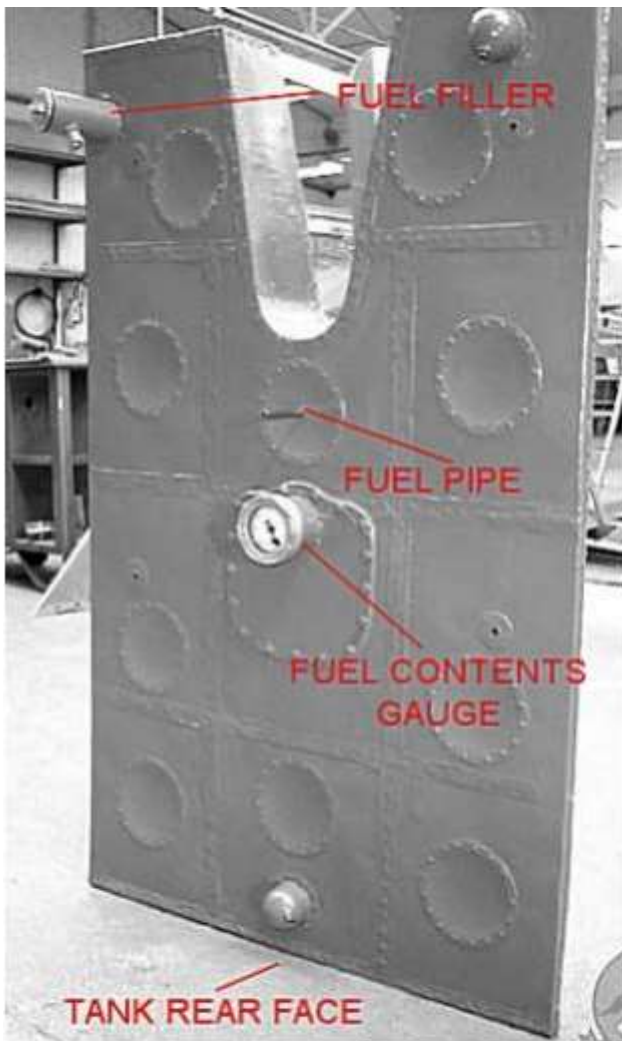

The kit supplied vent pipe (kit item C27) stops at the oil tank at the right of the pilot's seat. In reality this pipe continued over the oil tank and along the right cockpit beam then across to connect to the rear of the engine, between the two magnetos. I decided to replace this pipe with one created from brass micro-tube.

The locating hole in the top of the oil tank and the pipe hole in the cockpit coaming panel (C18) were drilled out to 1.2 mm diameter.

A short length of Albion Alloy's 1.2 mm diameter Brass tube (MBT12) was cut and a 0.8 mm hole drilled through one end.

A length of 0.8 mm diameter Brass Rod (BW08) was annealed over a flame then bent to form the correct shape for the routing of the pipe.

The pipe was inserted through the hole drilled through the 1.2 mm diameter tube, which was then inserted into the hole in the oil tank.

A length of 1.0 mm tube was cut and slid onto the vertical part of the tube.

NOTE: The engine end of the vent pipe is not modelled, as this can not be seen once the fuselage is finally closed up.

The fuselage halves were temporarily joined and the cockpit panel (C18) placed in position. The shape and alignment of the pipe were then adjusted and when correct, CA adhesive was applied into the top of the 1.2 mm diameter tube and to the 1.0 mm vertical pipe to fix the pipes in position. Once set the assembly was dismantled to free the pipe and the joints soft soldered.



4. Oil supply/return pipes to engine: The oil tank had two pipes which were connected to the rear of the engine. These pipes are not supplied in the kit.

The pre-molded 'pipe' from the oil tank was cut away.

Two holes of 0.8 mm diameter were drilled into the front face of the oil tank (top right and bottom left).

Two lengths of 0.8 mm Brass rod (BW08) were cut and annealed over an open flame.

The first tube was bent to shape to route from the top right hole in the oil tank and down and along to the end of the cockpit beam.

The second tube was bent to shape to route from the bottom left hole in the oil tank and out and along the outer edge of the cockpit floor, going under the rudder bar. A short length of 1.0 mm (MBT10), 1.2 mm (MBT12) and 1.6 mm (MBT16) were cut to the same length and slid onto the tube (one after the other) to create the increased pipe seen on the actual aircraft. These tubes were fixed to each other using thin CA adhesive. The engine end of the tube was bent through 90 degrees towards the centre of the cockpit floor.



5. Fuel supply pipe from ventral tank: Fuel was supplied from the ventral fuel tank up to the fuel tanks in the wing centre section through a pipe, which was routed from in front of the fuel contents gauge in the cockpit floor and across to the left fuselage side. To represent this pipe, two lengths of 0.5 mm diameter Brass tube (MBT05) were cut and bent to shape. A hole of 0.6 mm diameter was drilled through the cockpit floor forward from the floor mounted fuel contents gauge.

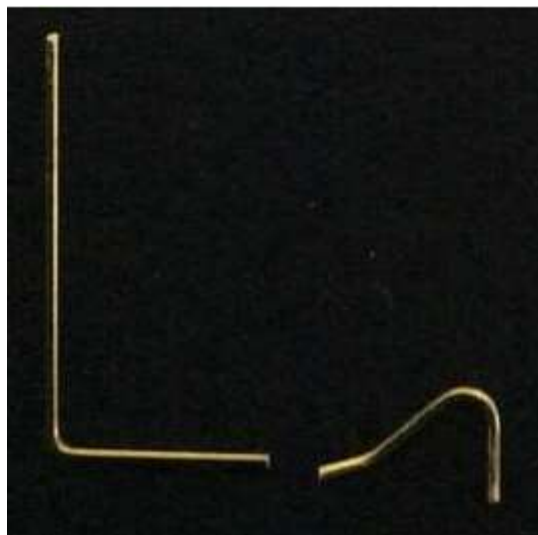

The following photograph shows the created pipes 'test' fitted in position.

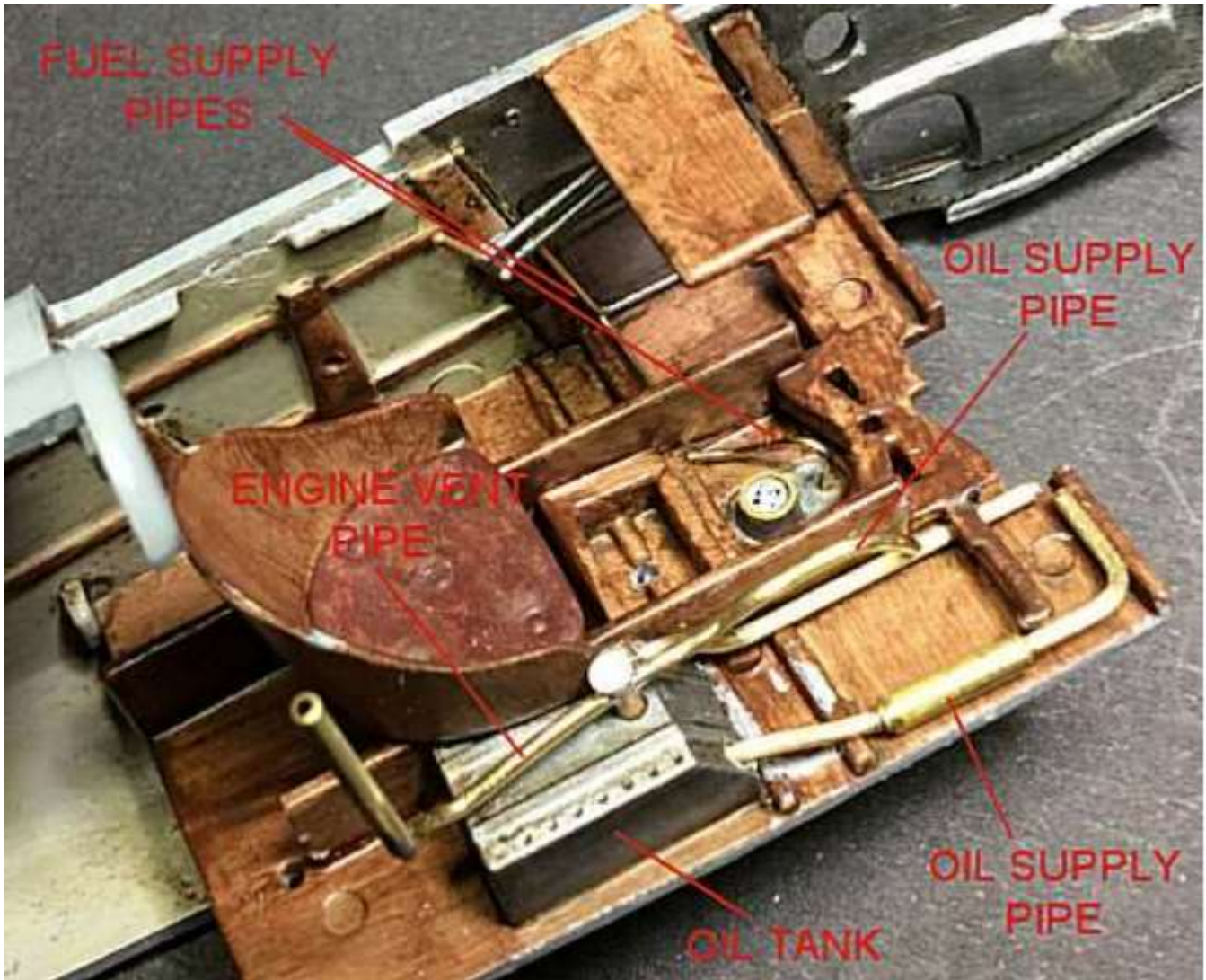

The pipes were all primed then airbrushed with Alclad Aluminium (ALC-101). Once dry the vertical pipe and cap on the oil tank and the larger diameter of the outer oil supply pipe were brush painted with Mr. Colour Master Brass (219). Small bands of Tamiya NATO Black (XF69) were brush painted on the tube ends to represent the flexible pipe connectors.

6. Fuselage and engine bay cross brace rigging. Cross braced rigging wires were fitted between the side frames on the cockpit sides, across the fuselage behind the pilot's seat and across the opening at the engine cooling panels on the forward fuselage sides.



As the cockpit frames are pre-molded as part of the fuselage sides, normal rigging techniques can't be used. Therefore to represent this rigging, micro-tube was used instead of rigging line (EZ, mono-filament etc).

Twelve lengths of Albion Alloys 0.2 mm diameter Nickel-Silver (NSR02) were cut to the correct length to span the cockpit frames.

Twelve short lengths of 0.4 mm diameter Brass tube (MBT04) were cut (represent turnbuckles) and then secured to one end of the 0.2 mm tubes with thin CA adhesive.

These were then attached to cross between the cockpit side frames using thin CA adhesive, with the 0.4 mm tube ends at the bottom (the tops are not visible when the fuselage is closed up).

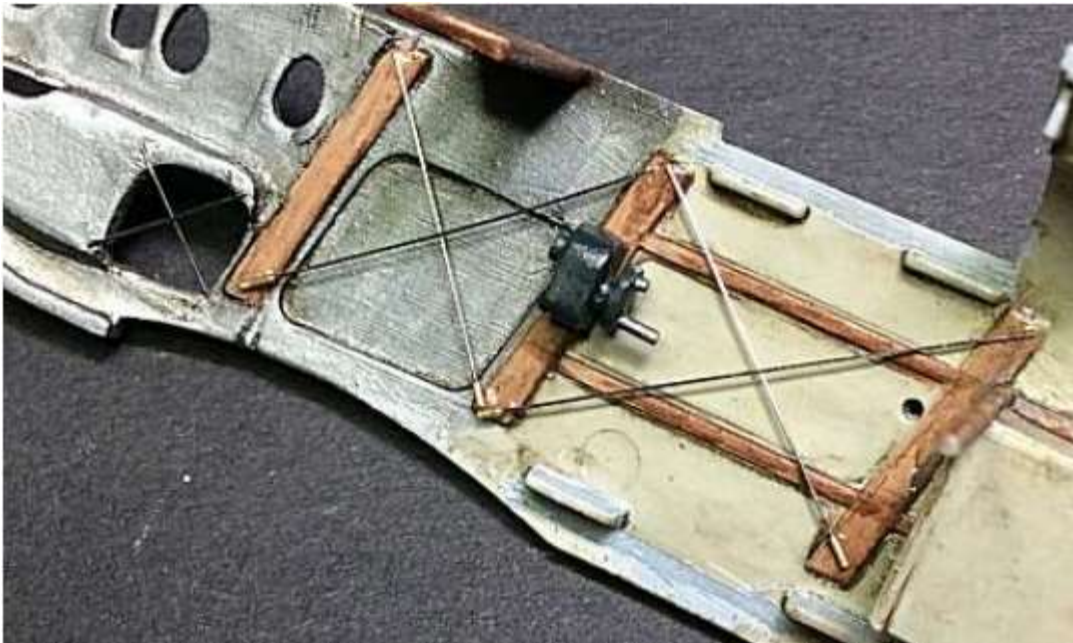

7. Instrument pipes. Some instrument etc in the cockpit do have attached and visible pipes or cables. For this model these are the magneto starter on the right fuselage half and the various instruments on the cockpit coaming panel. These were created by twisting two lengths of 0.12 mm diameter copper wire together, priming and brush painted with Tamiya NATO Black (XF69) and Mr. Colour Master Copper (215). Holes of 0.4 mm diameter were drilled through the cockpit coaming panel behind each instrument and also into the bottom of the magneto starter. The cables were then secured into or against the instruments using thin CA adhesive.



8. Flying control cables (rudder, aileron and elevator). (Refer to photos page 102 or 103).

To represent the flight control cables for the rudder, ailerons and elevator I used 0.1 mm diameter Nickel-Silver micro-tube (Albion Alloys NSR01).

Rudder - Two long lengths of tube were cut and routed under the pilots seat and rudder bar centre section to be secured to the front edge of the cockpit floor, using 'VMS' Fleky 5K' CA adhesive.

Elevator - Two long lengths of tube were cut and routed under the pilots seat and secured to the sides of the base of the control column, using 'VMS' Fleky 5K' CA adhesive.

Ailerons - Three short lengths of tube were cut and secured to the cockpit floor (each side and between the seat support beams), using 'VMS' Fleky 5K' CA adhesive.

9. Mallet (gun jams). (Refer to photos page 102 or 103). The machine guns fitted to WW1 aircraft often suffered from ammunition rounds jamming in the breech mechanisms. Pilots would often use a wood mallet, attached inside the cockpit, to repeatedly hit the breech of the machine gun in an attempt to free the rounds. The Spad carried such a mallet, which was attached on the inboard face of the left seat support beam. As the model kit does not supply this item, I used micro-tube to represent the mallet.

A short length of 1.0 mm diameter micro-tube (Albion Alloys MBT10) and 1.2 mm diameter (MBT12) were cut.

A 1.0 mm diameter hole was drilled into one side of the 1.2 mm tube.

The 1.0 mm tube was secured into the hole in the 1.2 tube, using thin CA adhesive.

The 'mallet' was primed then brush painted to represent wood (refer to Part 2 for how to create wood effects).

The mallet was secured to the inside of the left seat support beam using thin CA adhesive.

10. T-handle for fuel rip panel. (Refer to photos page 102 or 103). Fuel contained in the ventral fuel tank (in the lower fuselage) was able to be jettisoned in an emergency by the pilot pulling on a T-bar handle in the cockpit. This handle was connected by a cable to a detachable 'rip' panel fitted to the outside of the ventral fuel tank. When operated, the cable pulled the rip panel away to allow the fuel to escape to atmosphere. As the model kit does not supply this item, I used micro-tube to represent the T-bar.

Two short lengths of 0.5 mm diameter micro-tube (MBT05) were cut.

The tubes were secured to the front face of the oil tank, located on the cockpit floor to the right of the pilot's seat.

The tubes were primed and brush painted with Tamiya Red (XF7) mixed with NATO Black (XF69) to darken it slightly.

11. Rudder bar foot straps. (Refer to photos page 102 or 103). As was normal in WW1 aircraft, feet retaining straps were fitted to the foot rests of the rudder bar. As the model kit does not supply these straps, they were created using 'Plus Model' lead wire (0.4 mm diameter), bent to a semi-circle and attached to the rudder bar using thin CA adhesive. They were primed then brush painted with Humbrol Leather (62).

12. Control column mounted gun firing cables. (Refer to photos page 102 or 103). Most WW1 fighter aircraft had machine gun operating cables fitted to the pilot's control column. These cables were routed forwards to either the gun synchronisation gear or the machine gun mechanism. The Spad XIII had twin operating cables fitted to the pilot's control column. To represent these cables I used micro-rod and lead wire.

Two short lengths of 0.2 mm diameter Nickle-Silver micro-rod (Albion Alloys NSR02) were bent into small semi-circles.

These were attached to the forward top of the control column using some thin CA adhesive to represent the trigger 'finger rings'.

To represent the two operating cables, lengths of lead wire ('Plus Model' lead wire 0.3 mm diameter) were attached to the two trigger rings on the control column with thin CA adhesive.

The two lead wires were left long enough to be routed up and under the cockpit coaming panel.

13. Pilot seat straps. (Refer to photos page 102 or 103). The Spad XIII had seat restraint straps fitted to hold the pilot in the seat. These straps consisted of two shoulder straps and two lap straps. The two shoulder straps were attached to a fuselage cross member behind the pilot's seat and were routed through the centre cut-out in the fuselage frame above and behind the pilot's head. Two lap straps were attached to either the outside of the pilot's seat or to the seat support. As there doesn't seem to be an aftermarket set of seatbelts for this aircraft, I utilised straps from the 'HGW' textile seatbelts (132543).

NOTE: When assembling the seat straps, **do not fit** the cross strap to the two shoulder straps, as this needs to be fitted after the straps are routed through the top cockpit frame above the pilot's seat.

Assemble the seat straps in accordance with the HGW instructions.

NOTE: At the top ends of both shoulder straps, wrap the ends around a 1.2 mm diameter micro-tube to form a loop and secure with thin CA adhesive. These loops will be slid onto the forward cross member bar fitted onto the inside of the right fuselage half in Part 1 of this build log. The belts will be inserted through the top frame behind the pilot's seat during the models construction in Part 12 of this build.

Apply either a thinned oil wash (see HGW instructions) or a light wash of 'AK Interactive' engine oil (AK 2019).

Attached the two lap straps using 'Fleky CA 5K' adhesive. Secure the strap end fittings to the seat cushion and the 'anchor' ends to the outsides of the seat support beams, to the rear of the pilot's seat. If necessary, also secure the straps to the seat edges to maintain the straps shape.

The following photographs show the assembled cockpit, after closing the fuselage.

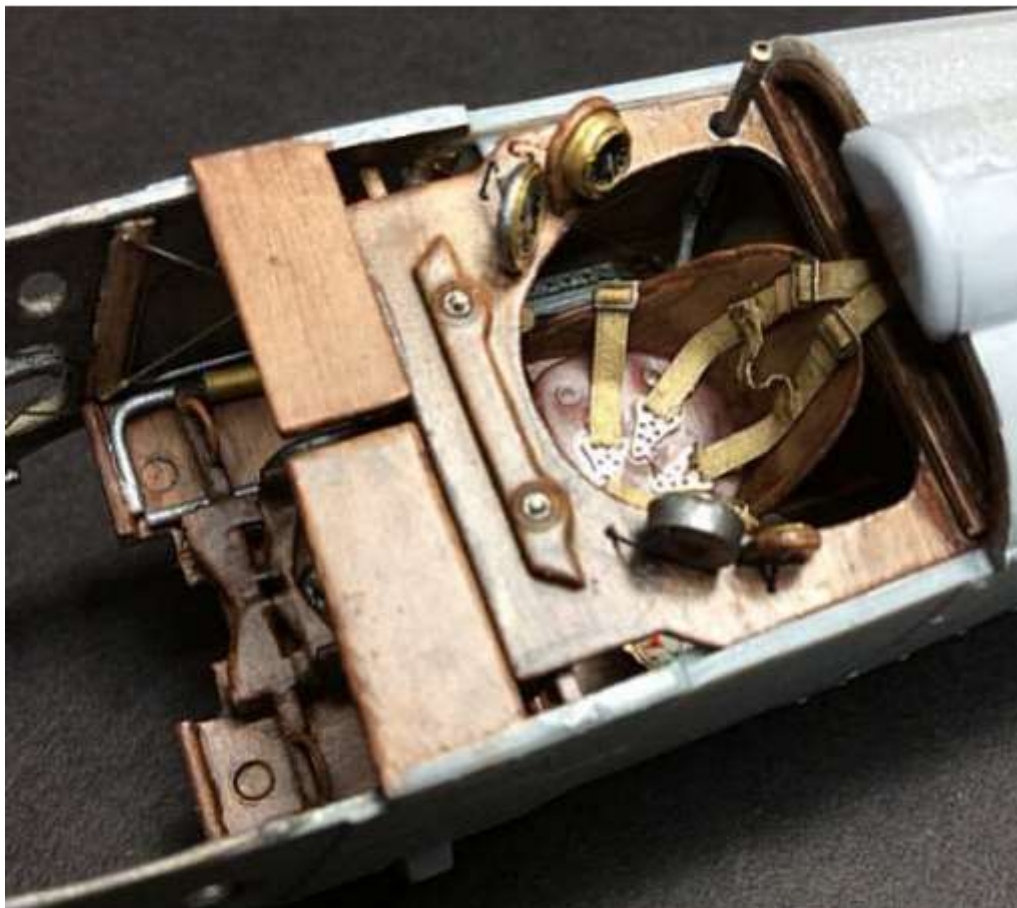

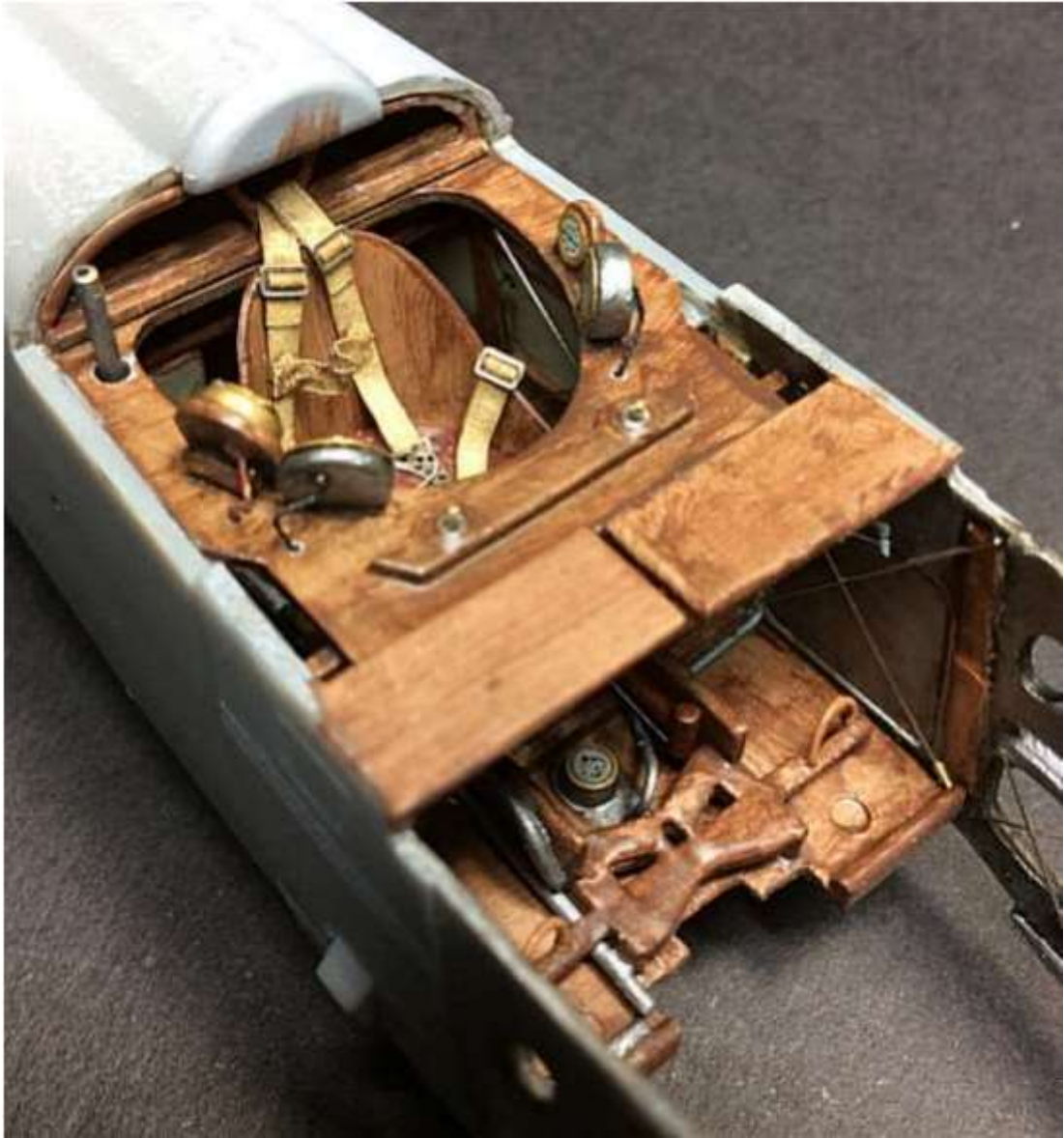

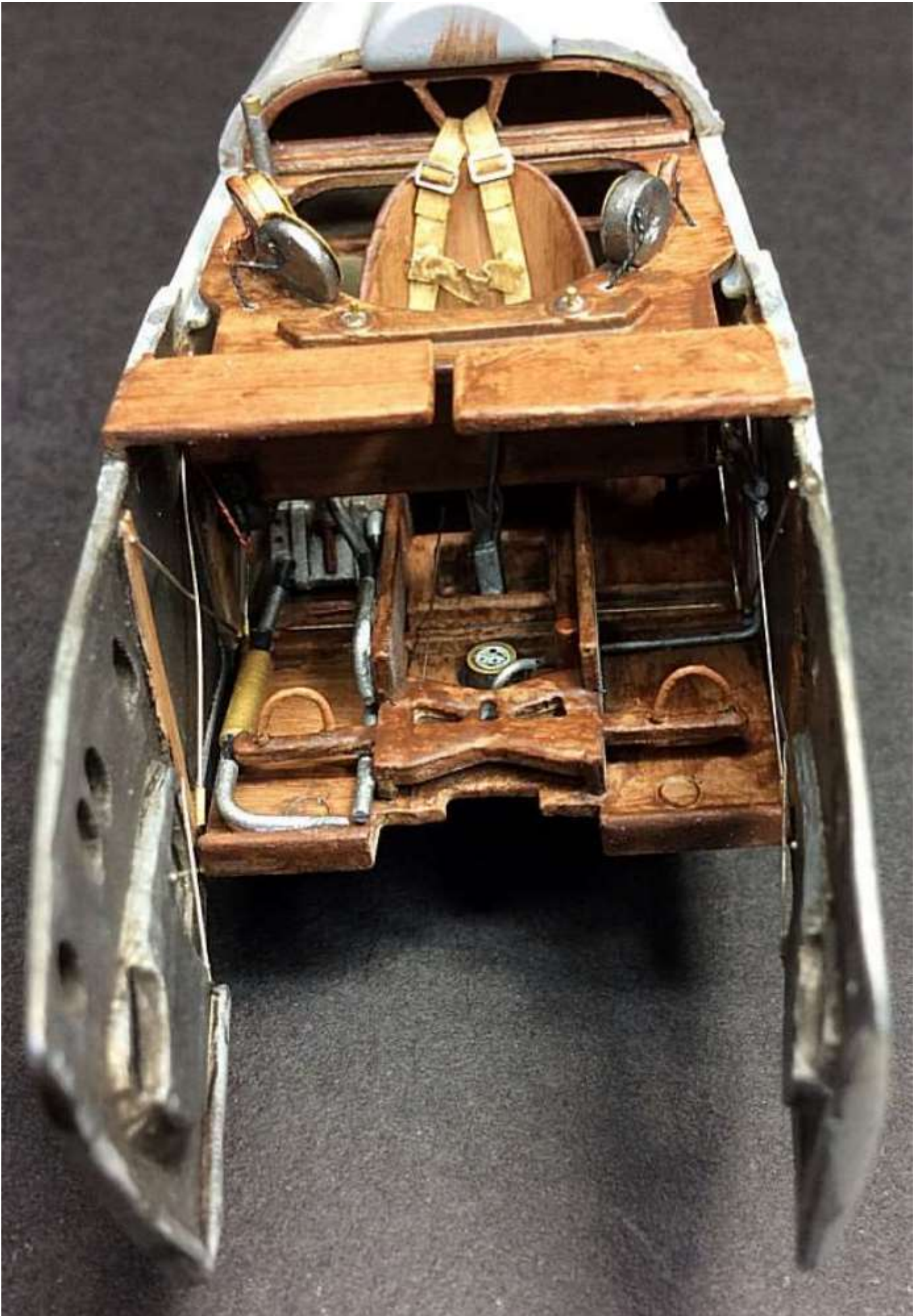

PART 5 - THE ENGINE

The engine of the Spad XIII was a geared Hispano-Suiza engine, the first version of which was the 8Ba, providing 200 hp (150 kW). A later version was a high-compression 8Bc or 8Be, which delivered 220 hp (160 kW).

NOTE: Some of the following 'draw' images are of the Wolseley manufactured version of the Hispano-Suiza engine, which is similar in its design to the Spad engine. The photographs are of an installed Spad Hispano-Suiza engine.

Cooling system:

The engine cooling system consisted of a 'oval' shaped radiator with pilot operated shutters to adjust the water temperature. The coolant header tank was installed in the leading edge at the centre of the upper wing. The coolant was fed from the header tank, through a pipe inside a fairing between the upper wing and fuselage. The pipe was routed over the top of the engine to the coolant filler assembly to maintain a head of coolant pressure in the system. The filler assembly fed coolant into the expansion tank in the top of the radiator. The air cooled coolant was drawn out of the bottom of the radiator and through a pipe to the engine driven water pump, located below the rear of the engine. The centrifugal type pump circulated coolant through two pipes to the outer sides of the engines cylinder blocks, then through the engine to exit from pipes at the top front of the cylinder block. These pipes were connected to the coolant filler assembly.

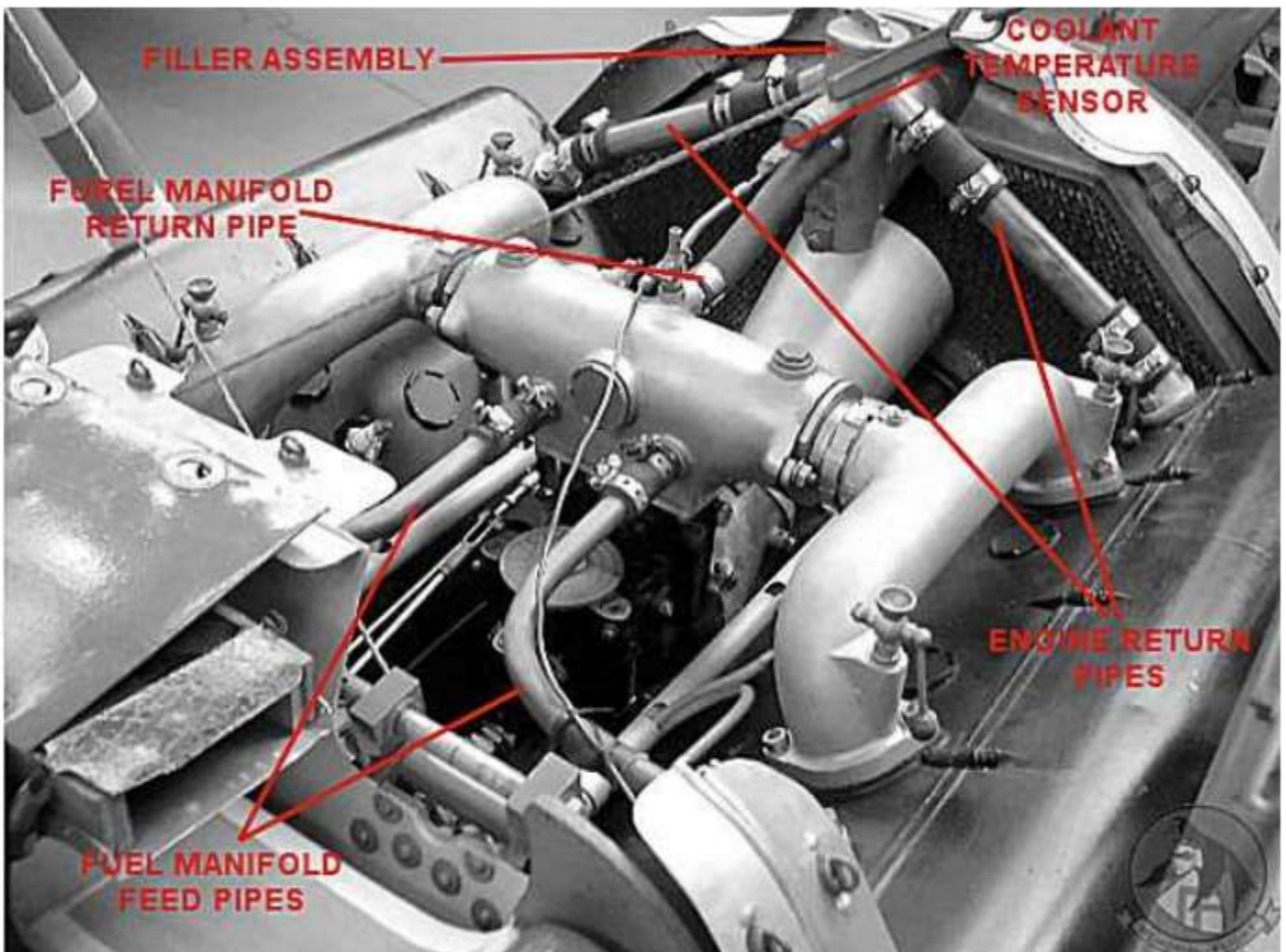

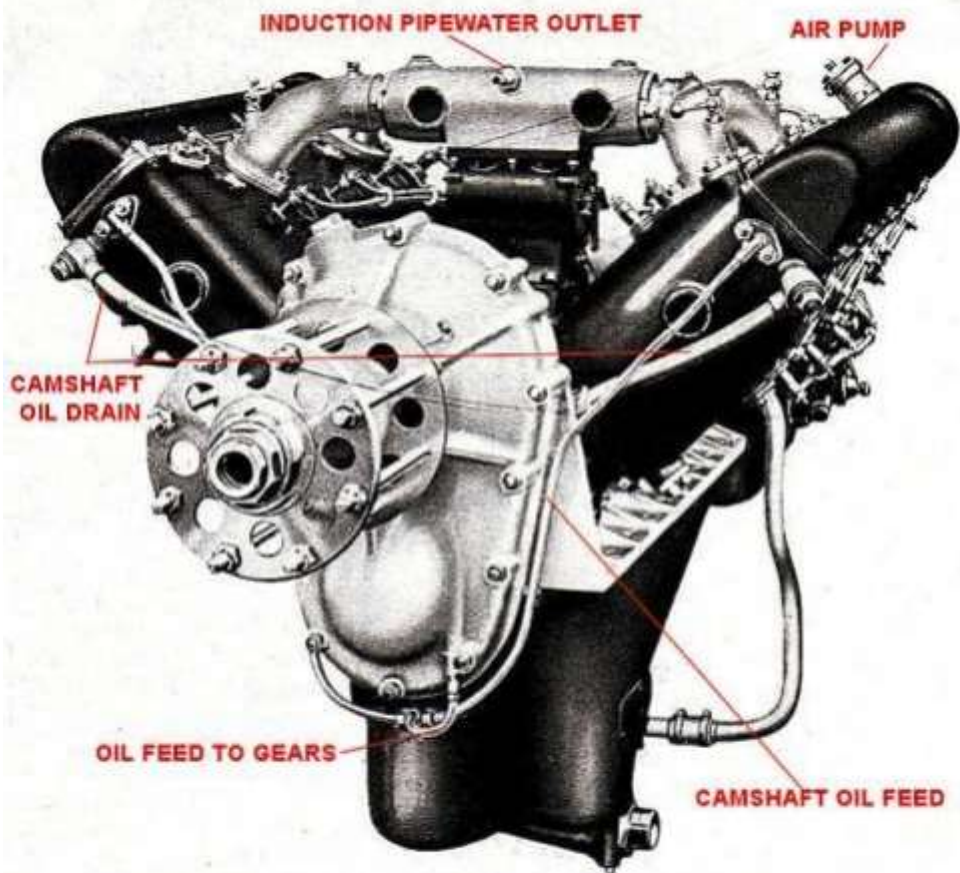
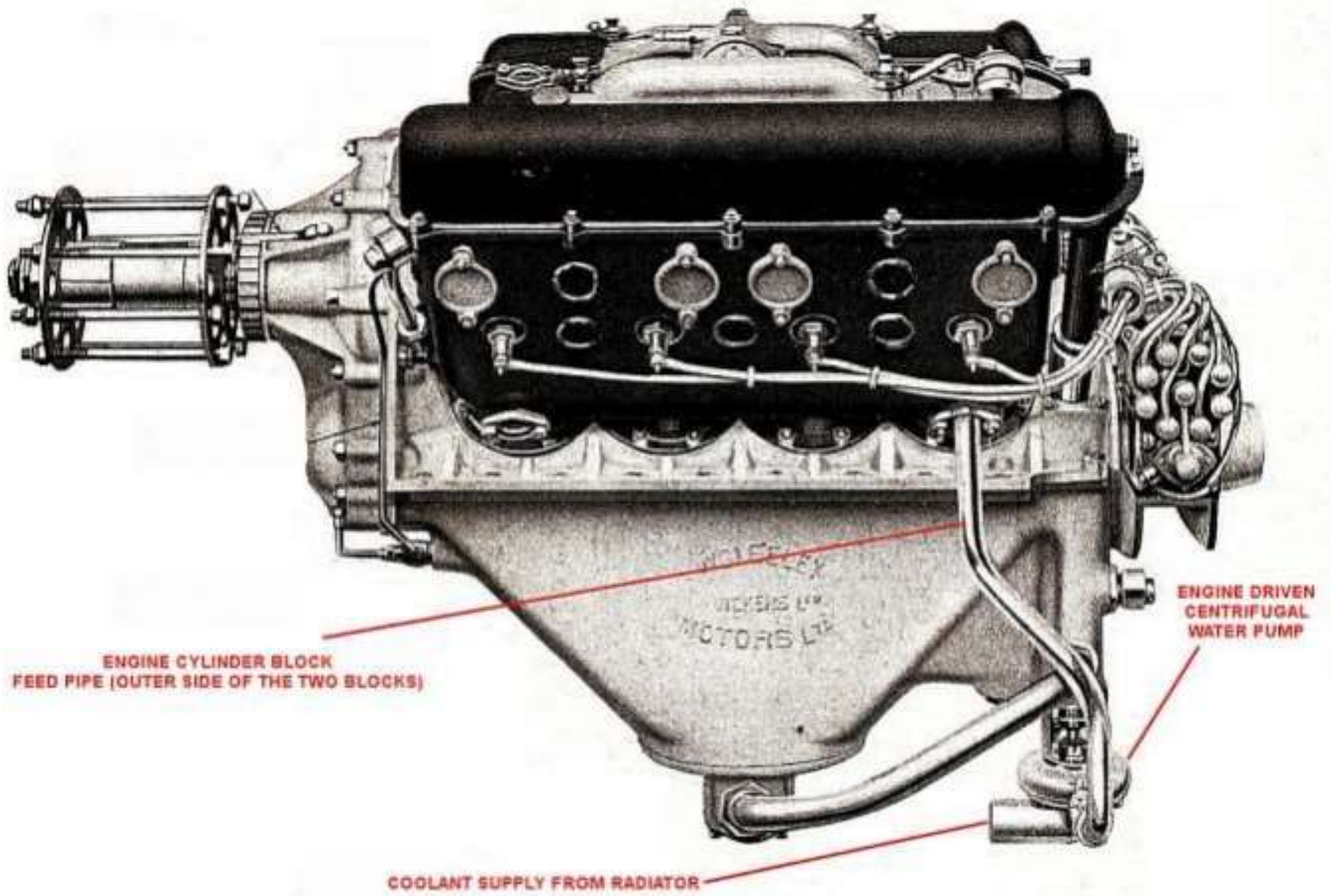

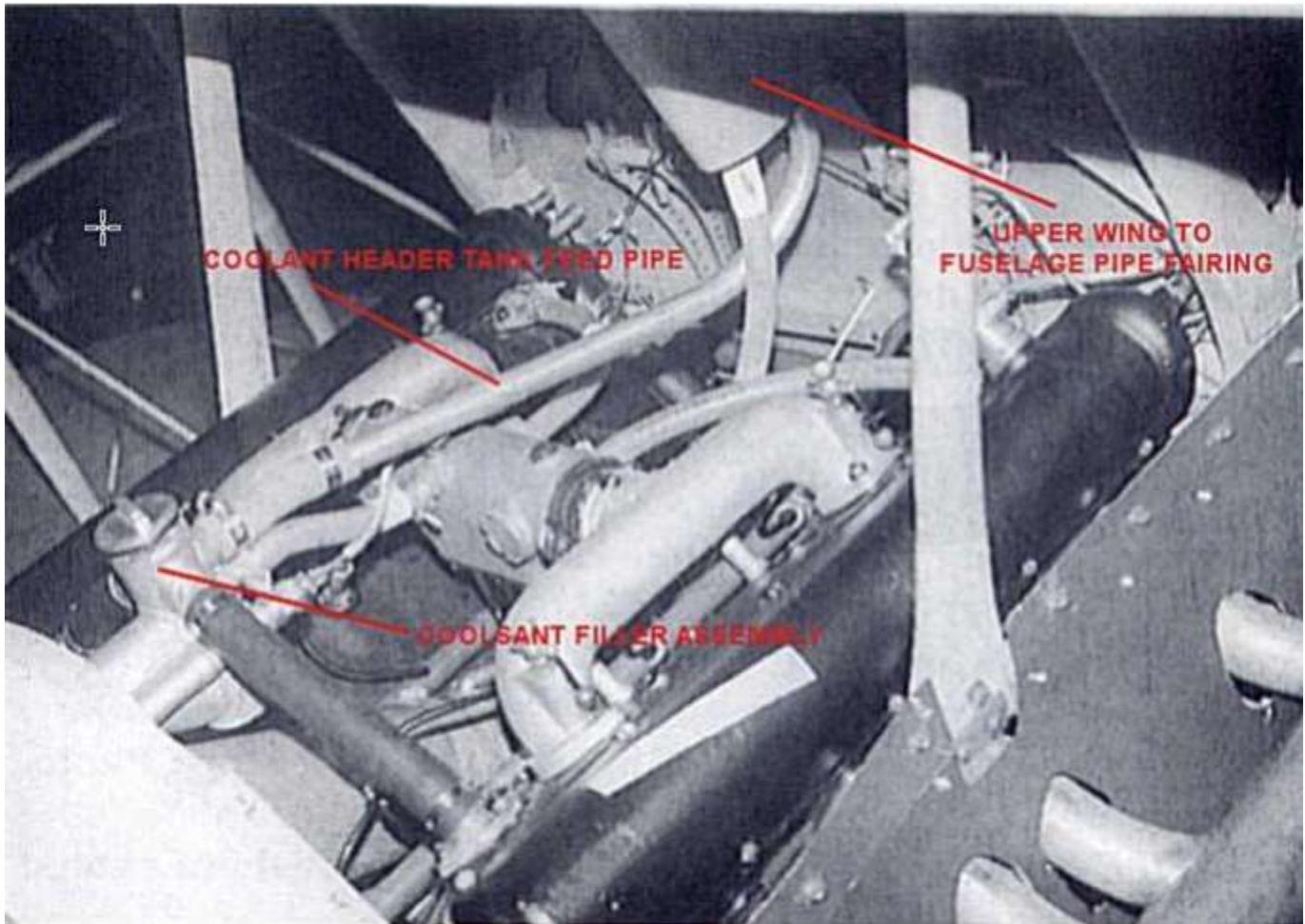

Fuel System:

The fuel system consisted of 'ventral' fuel tanks located in the bottom of the fuselage and auxiliary fuel tanks fitted in the leading edge of the upper wing, to the rear of the engine coolant header tank. The fuel was supplied to the inlet connection at the rear of the carburettor assembly. The fuel from the carburettor was fed through a water heated manifold to each cylinder head through separate inlet manifolds. Two fuel primers were fitted to each inlet manifold.

Burnt fuel exhaust from each cylinder was ejected through a stub pipe and into the exhaust pipe on that side of the engine.

To allow the pilot to jettison fuel in an emergency, the pilot was able to manually operate a detachable flap, which was fitted to the ventral fuel tank assembly. When the pilot pulled the handle of the operating cable, the flap was 'ripped off' the ventral tank releasing the fuel to atmosphere.

A fuel contents gauge was installed on the ventral fuel tank assembly and was visible in the cockpit floor in front of the pilot's seat.

NOTE: Despite researching the fuel system, I was unable to determine exactly how the fuel tanks were filled or how the fuel from the tanks was supplied to the engine. There is a pipe that connects the upper wing auxiliary tanks to the engine through a fairing between the upper wing and fuselage. There is also what some suggest is the fuel filler pipe, which is located through the right side of the cockpit adjacent to the pilot's shoulder. This pipe is capped with either a filler cap or a vented cap? This pipe is connected to the oil tank filler pipe and appears to run forward and across the cockpit floor to connect to the engine between the two magnetos. This pipe could be an engine breather pipe, venting through the cap. As a fuel filler pipe it would seem dangerous to be filling a fuel tank from a pipe next to the cockpit!! Also both upper wing auxiliary fuel tanks have what seems to be filler caps and the sump of the ventral fuel tanks also has a cap.

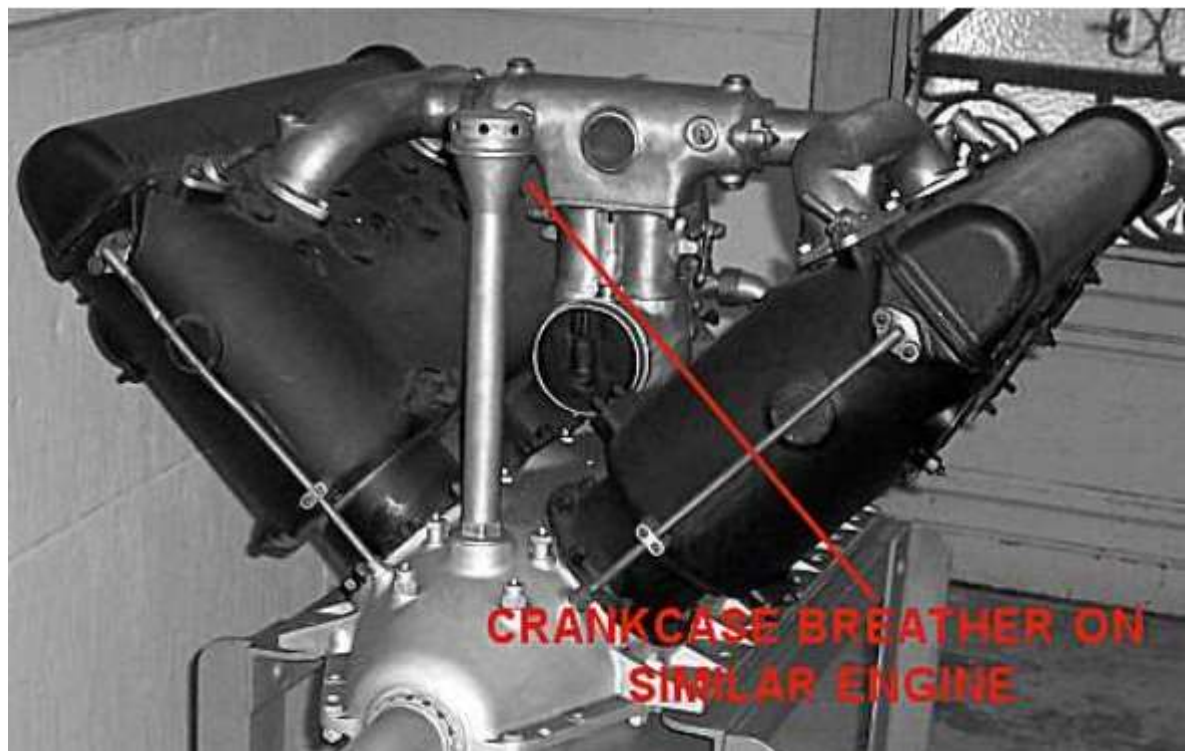
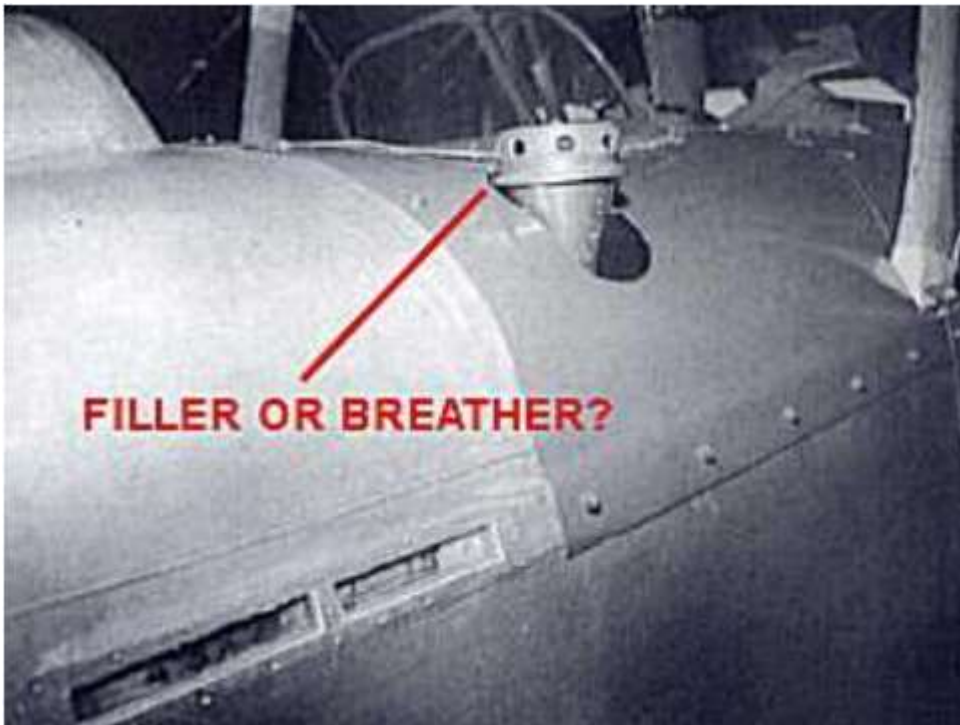

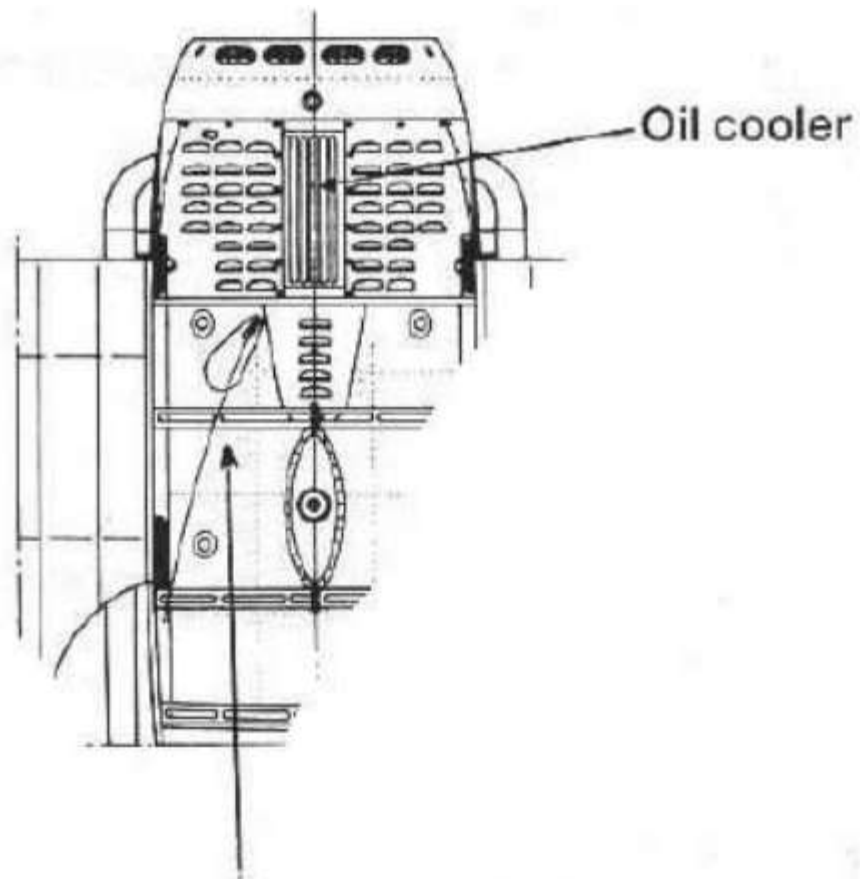
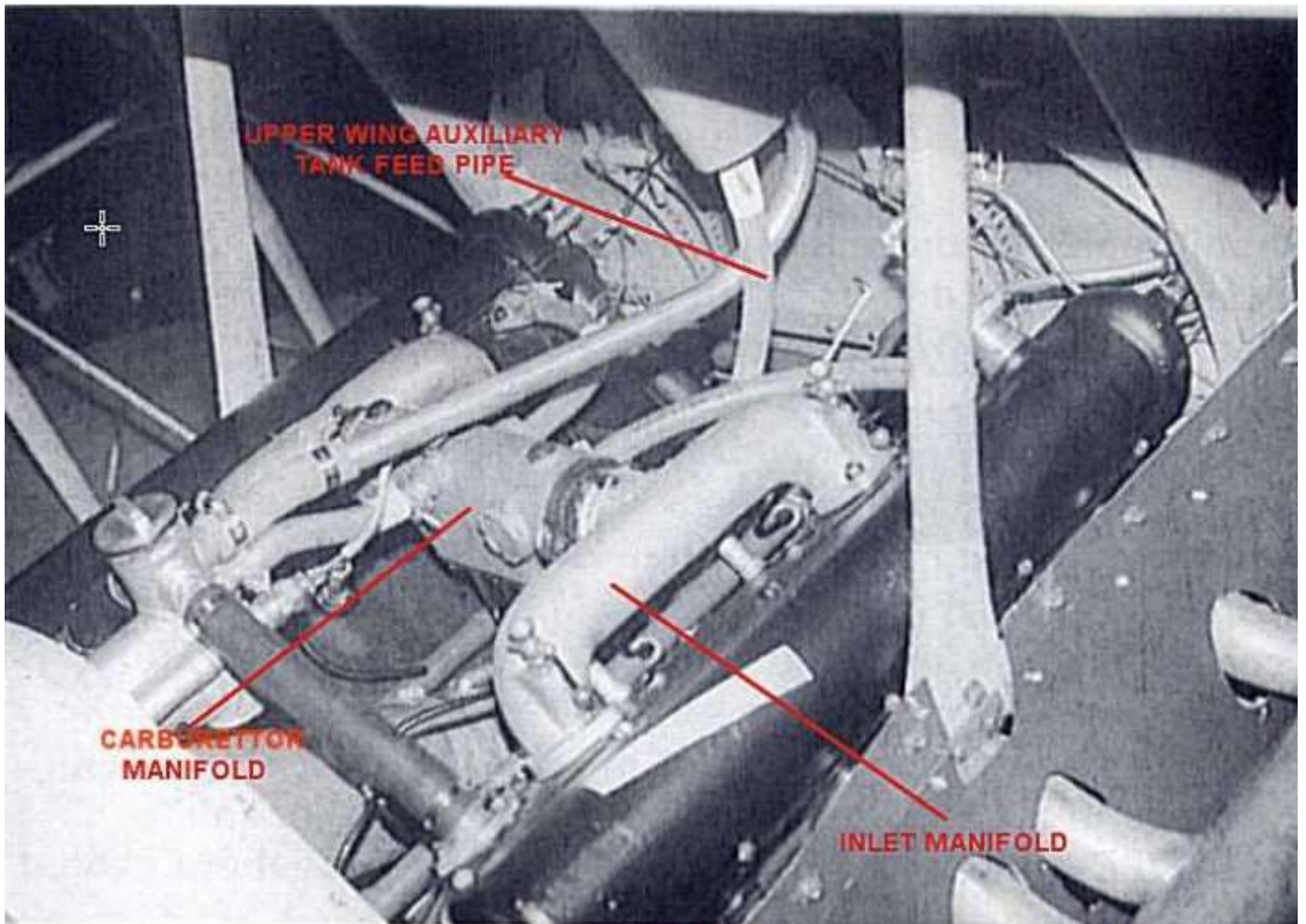

Rip panel and cable to cockpit for emergency fuel jettison

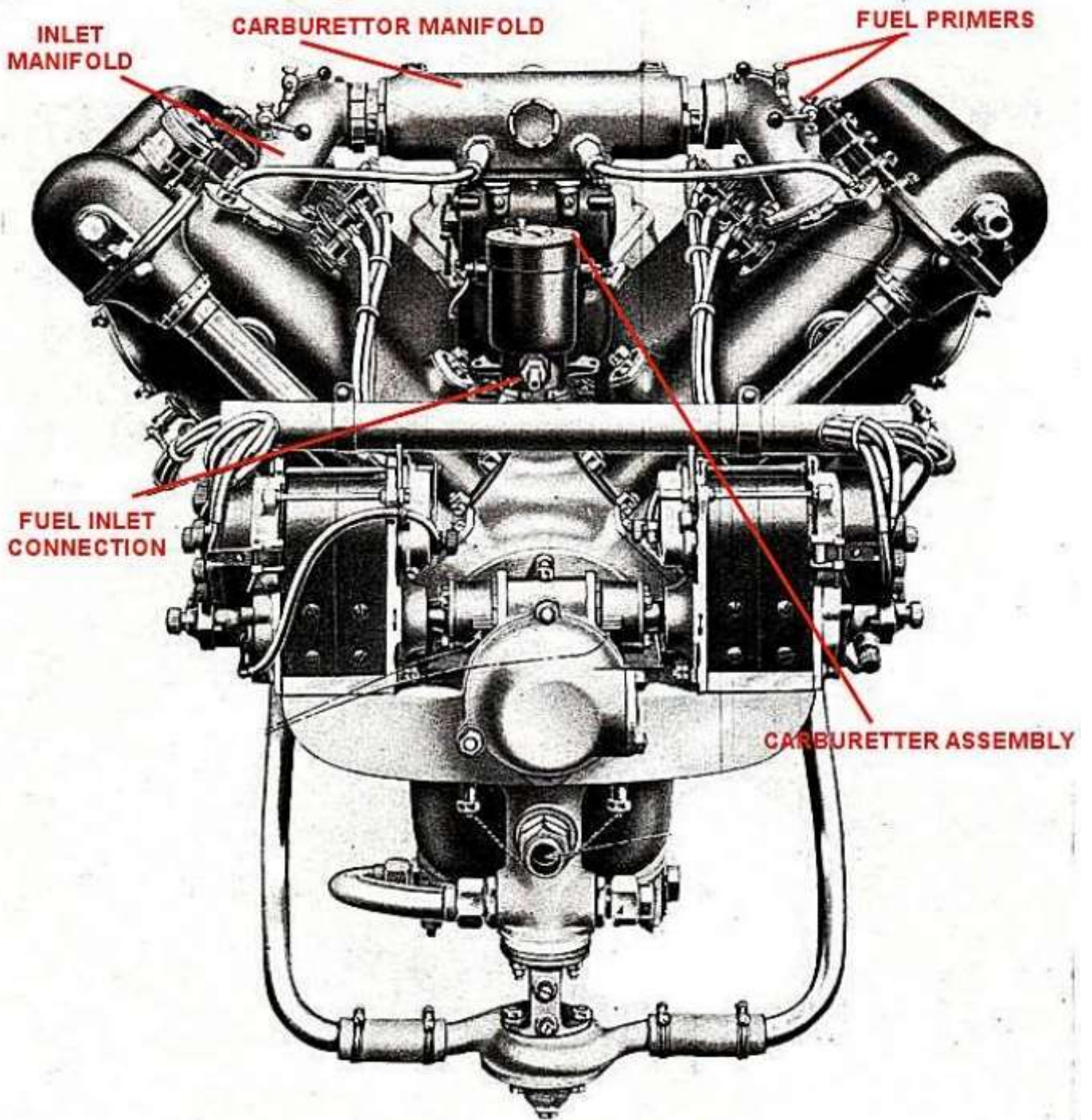

Lubrication system:

The engine oil storage tank was fitted onto the cockpit floor to the right of the pilot's seat. A capped filler pipe was located in the top of the tank. A pipe from the base of the tank supplied oil to the engine driven oil pressure pump, located above the engine driven water pump on the lower rear of the engine. The oil was pumped through an internal supply gallery to lubricated the crankshaft bearings and was also fed through external pipes, up the front of each cylinder block, to lubricated the camshaft and valve gear. Oil drained down through the engine into the oil sump at the bottom of the engine, from where the oil was drawn through the oil cooler (located in the underside of the forward fuselage) by the oil scavenge pump. The scavenge pump fed the cooled oil through a pipe back into the oil storage tank.

The connection feeding the cockpit oil pressure gauge in the cockpit was located in the oil pumps housing at he rear of the engine.

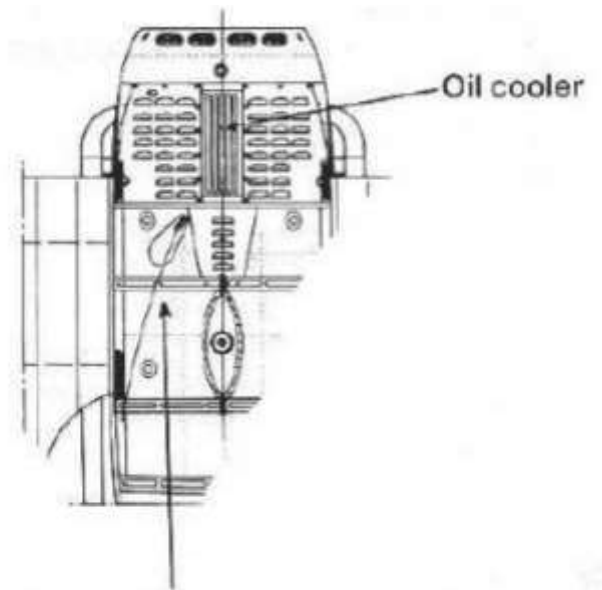
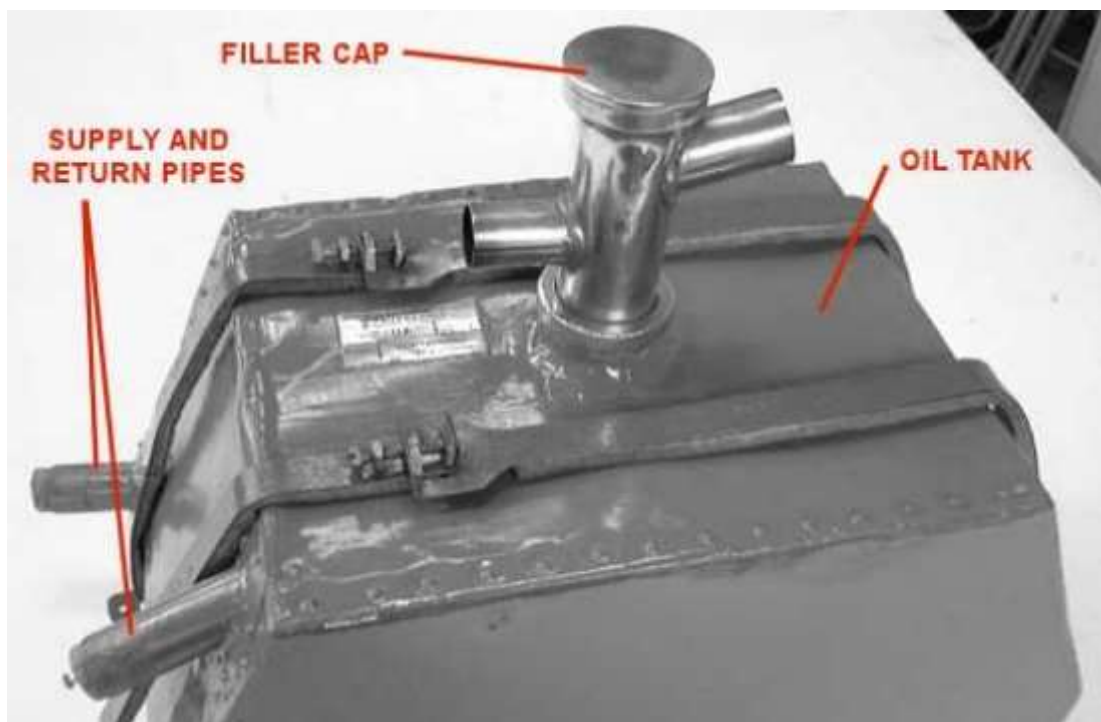

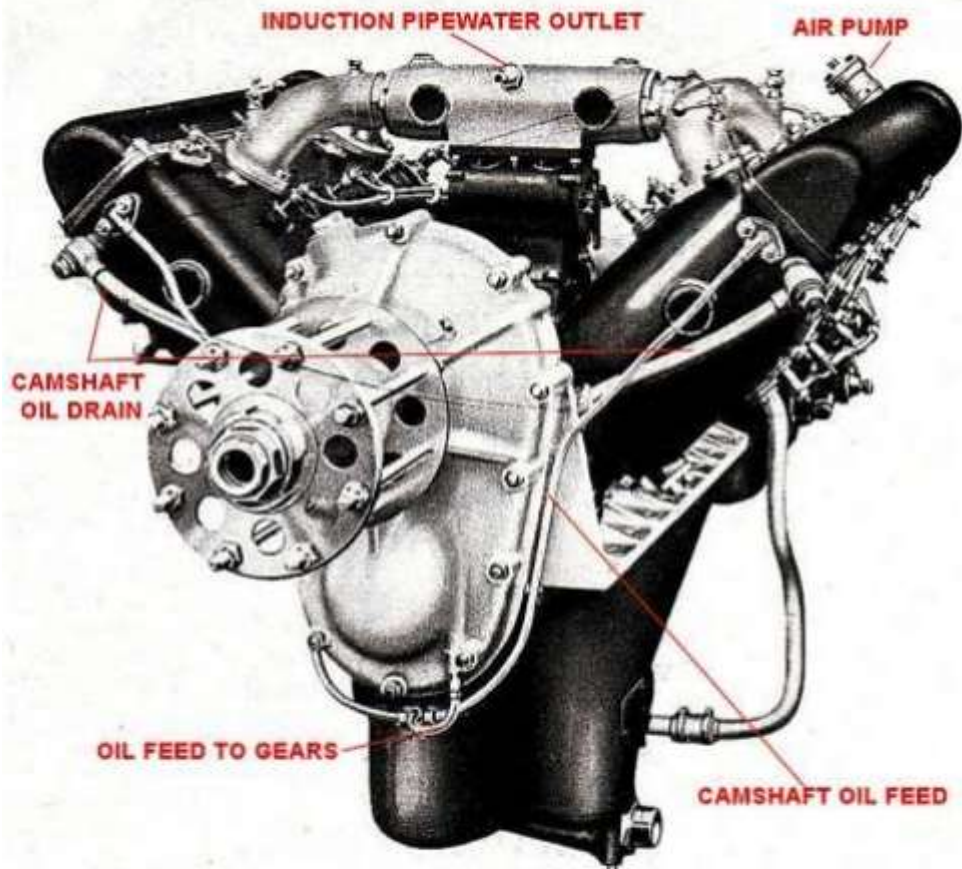
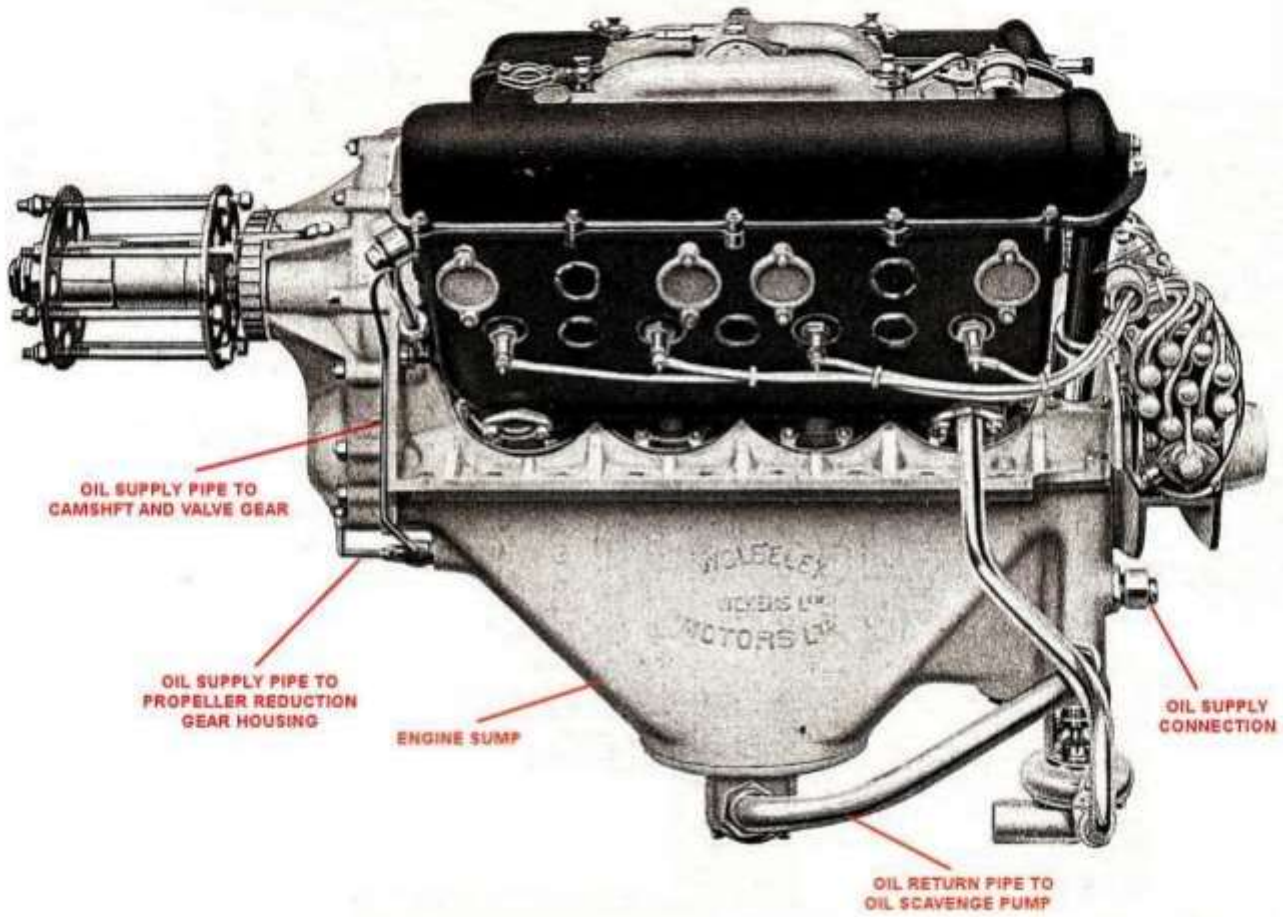

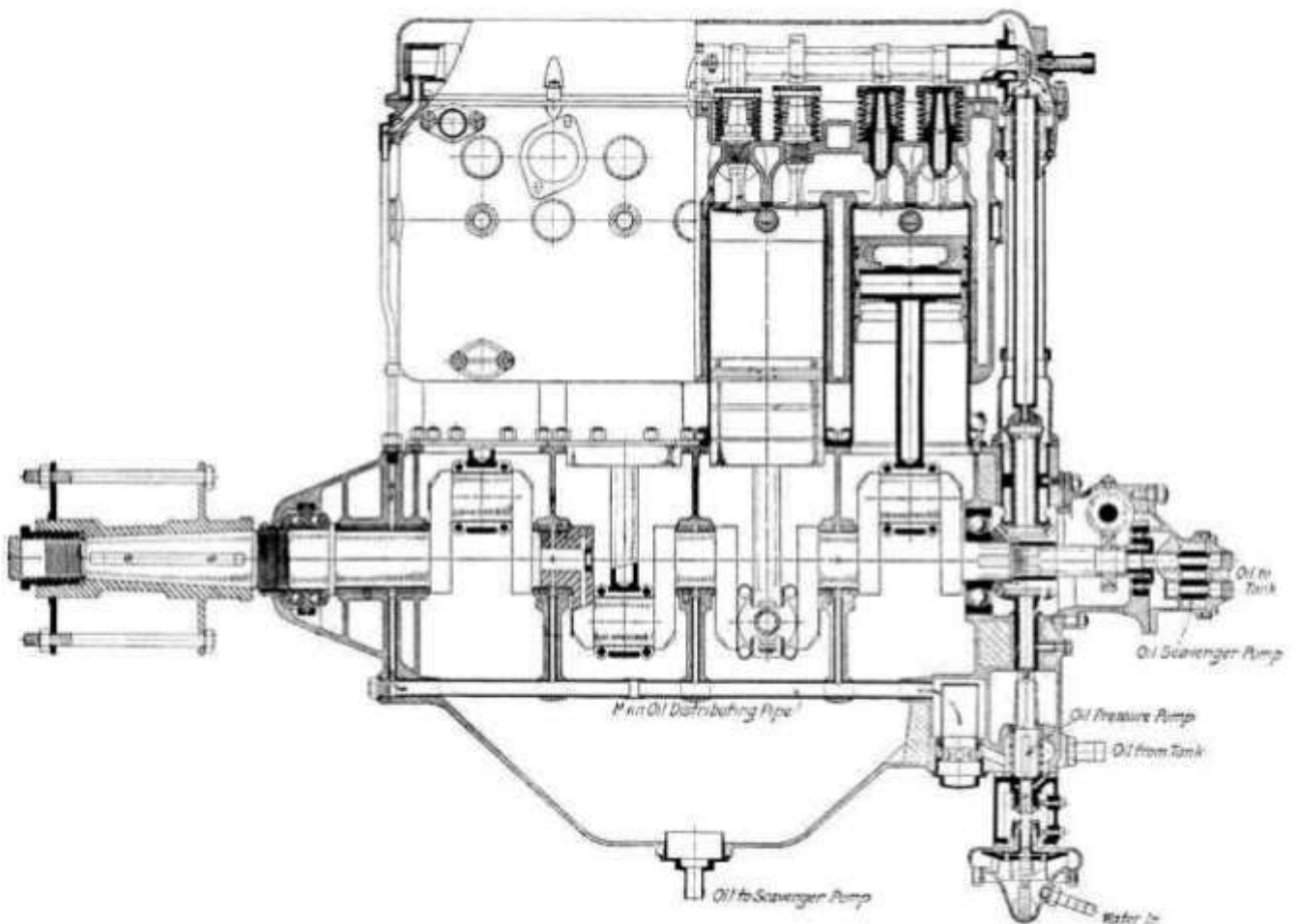

Ignition system:

The engine's ignition system for the 8 cylinders was provided by two magnetos, located on a support beam at the lower rear of the engine. Each engine cylinder was provided with two spark plugs (16 in total), one at each side of each cylinder housing. Distributer drive shafts connected the magnetos to the camshaft housing on each cylinder bank. Connected to each magneto were 8 ignition leads, which were routed through an opening at the rear of a support tube. From here 4 of the ignition leads were routed out of the open end of the support tube and connected to the 4 outer spark plugs on that cylinder bank. The remaining 4 ignition leads were routed through an opening at the forward face of the support tube to be connected to the 4 spark plugs on the inner face of the cylinder bank. The same was repeated for the other magneto connections.

DISTRIBUTER DRIVE SHAFT CASING

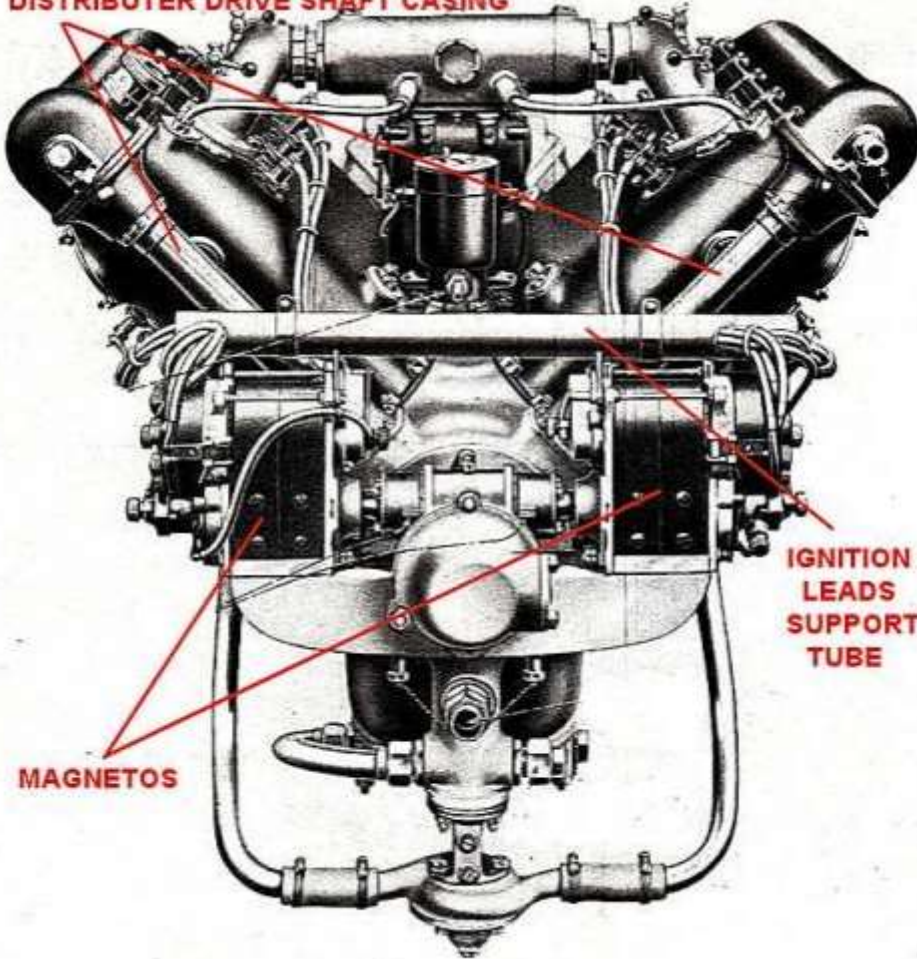

MAGNETOS

**IGNITION
LEADS
SUPPORT
TUBE**

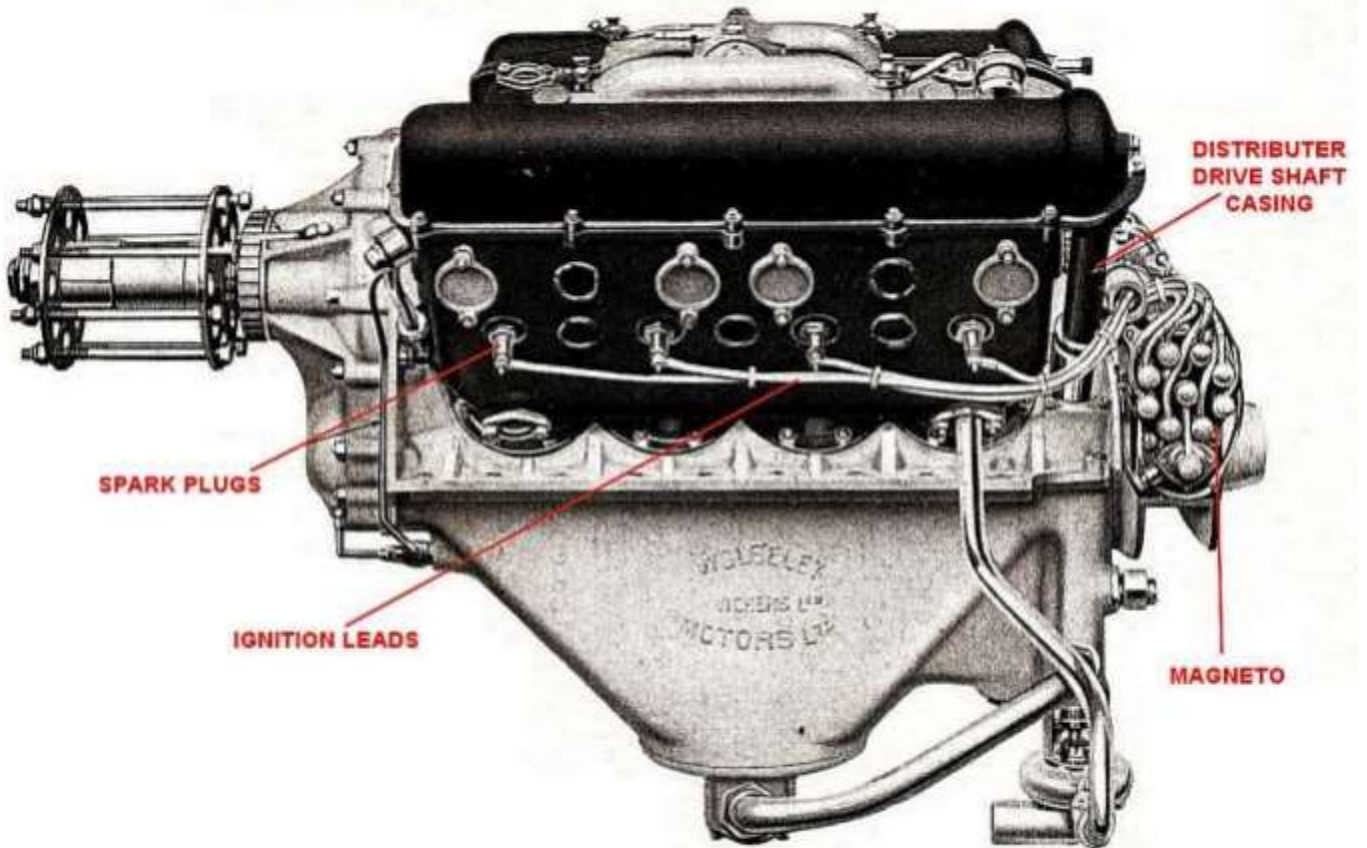

SPARK PLUGS

IGNITION LEADS

**DISTRIBUTER
DRIVE SHAFT
CASING**

MAGNETO

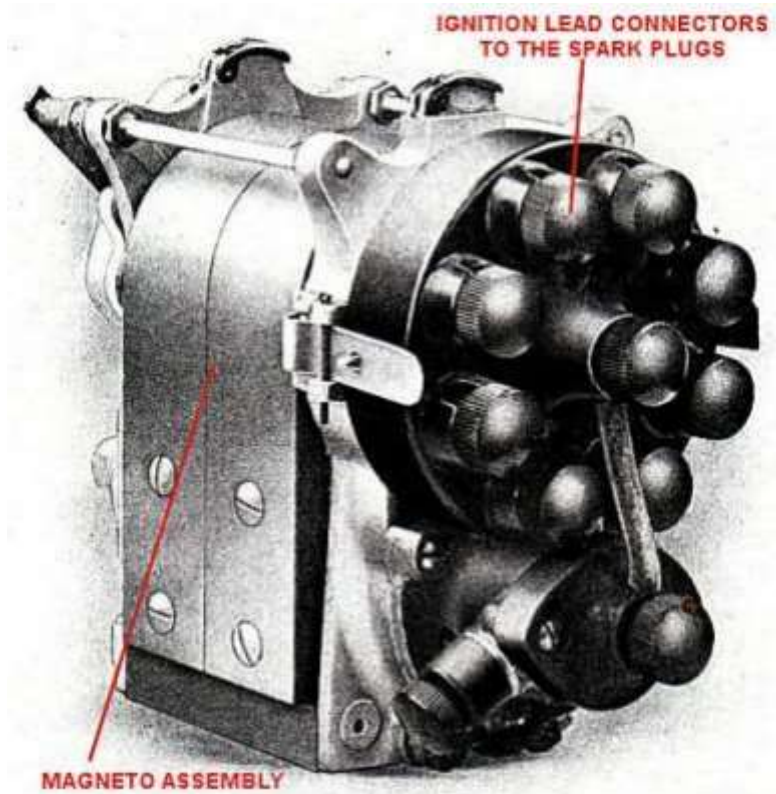

Engine installation (general images non - specific)

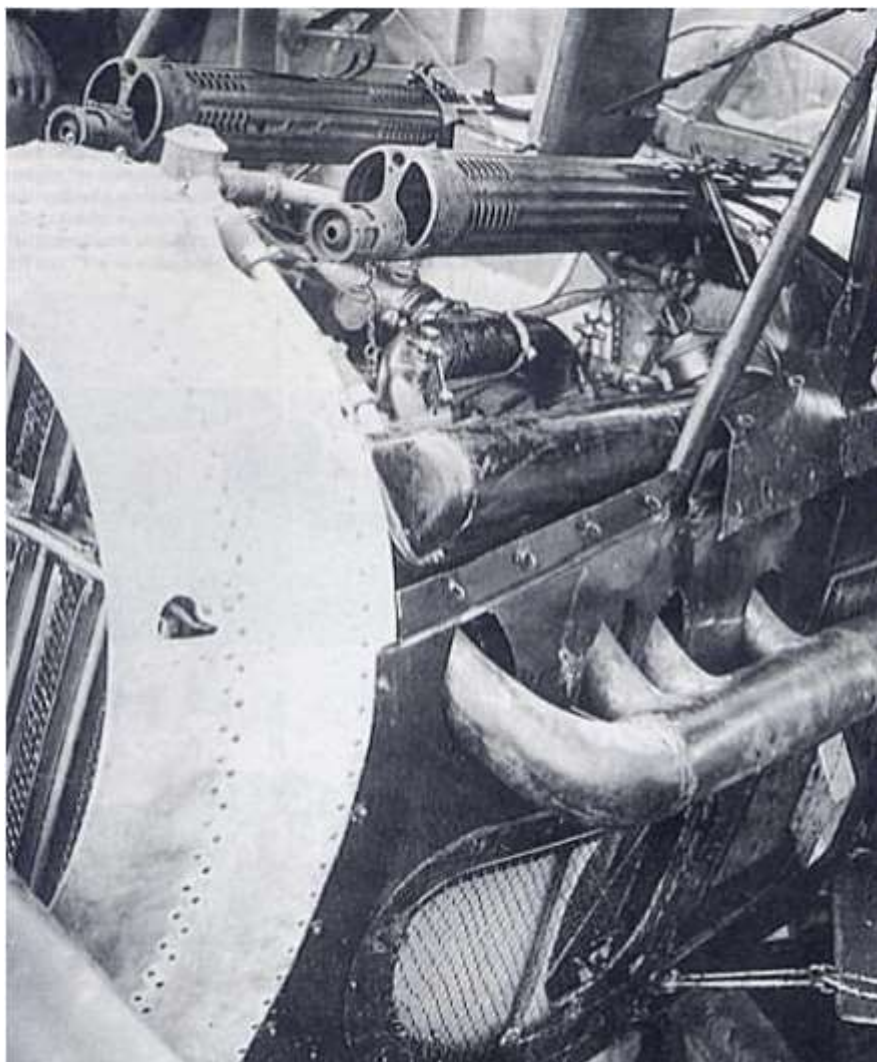

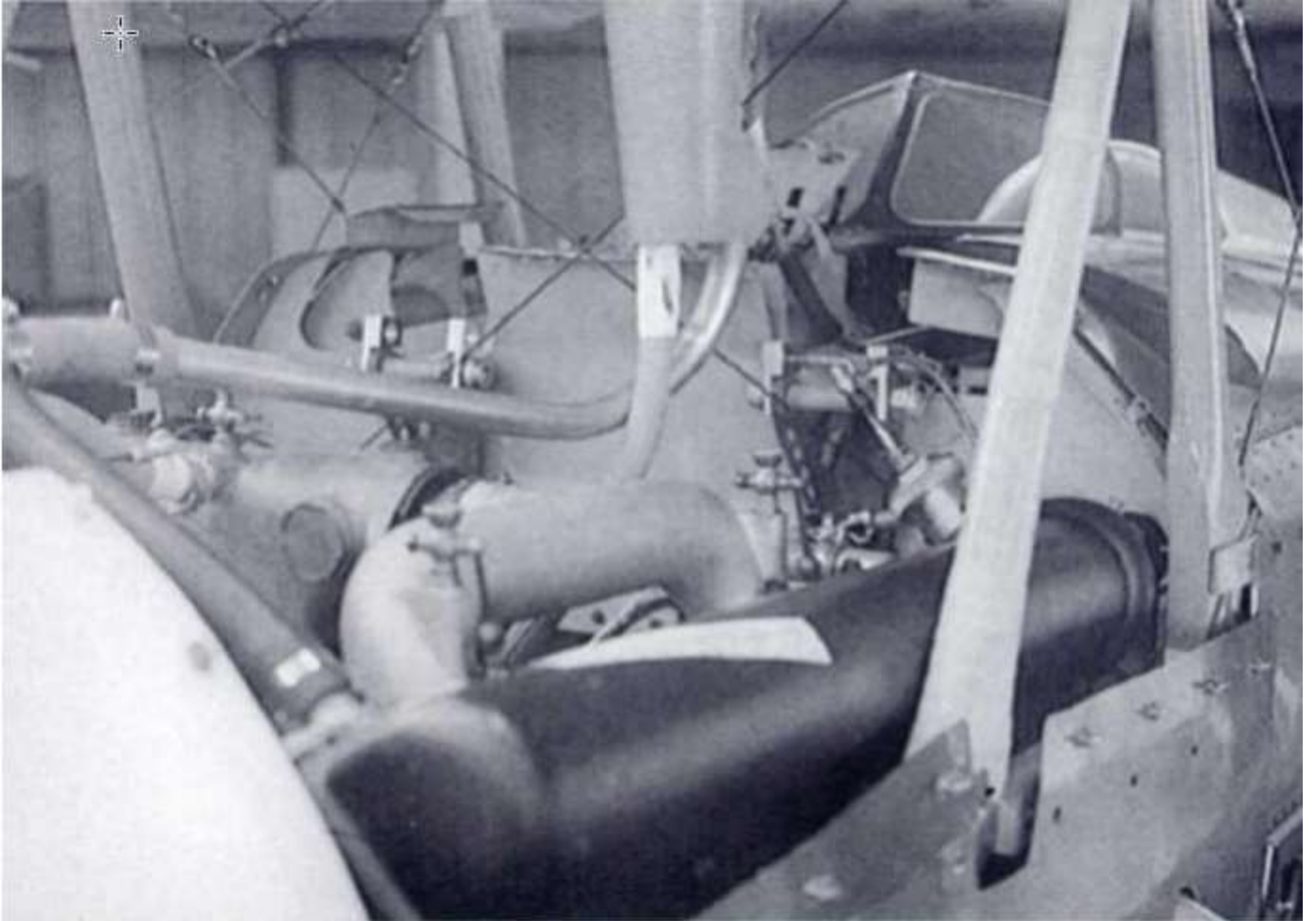
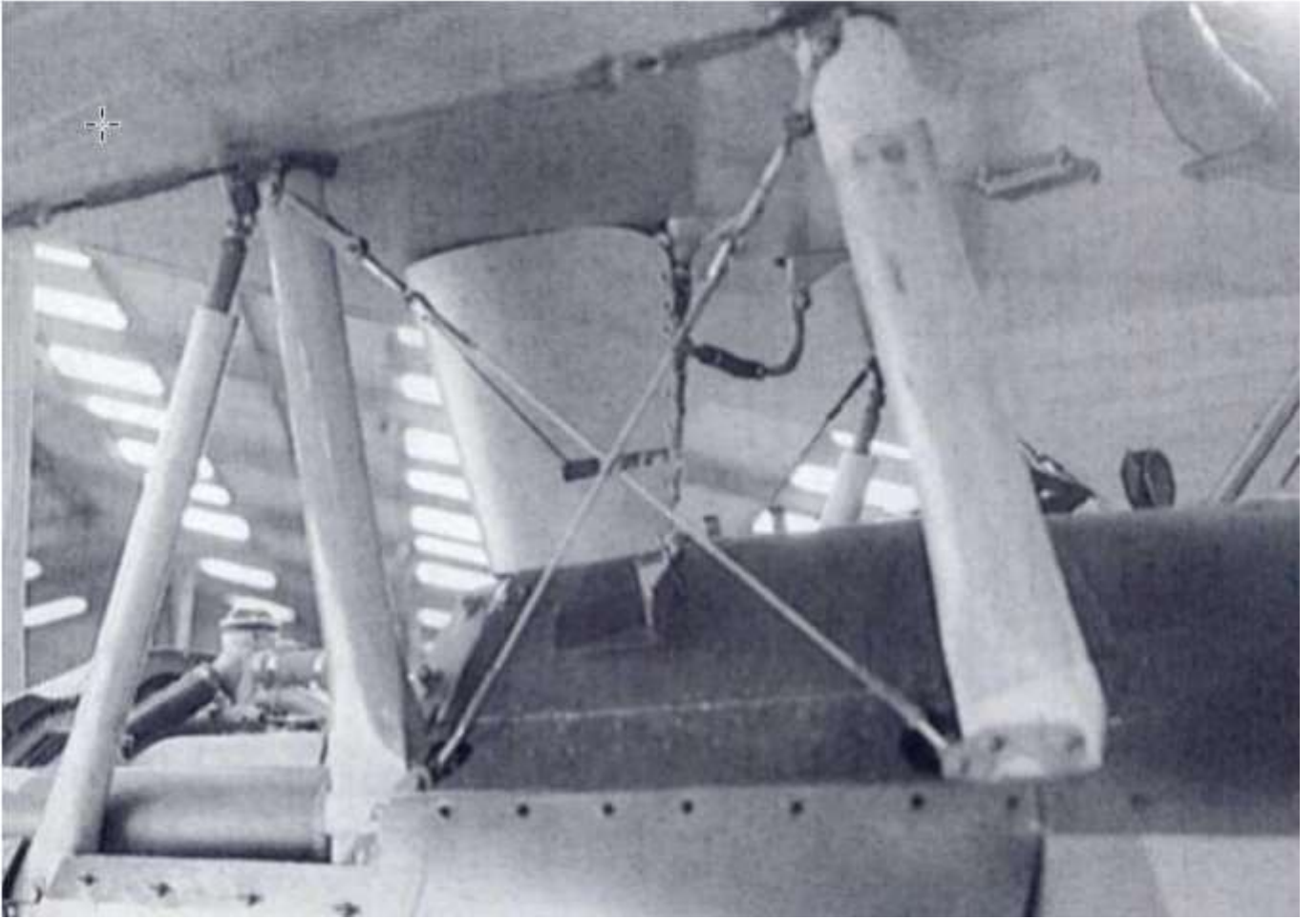

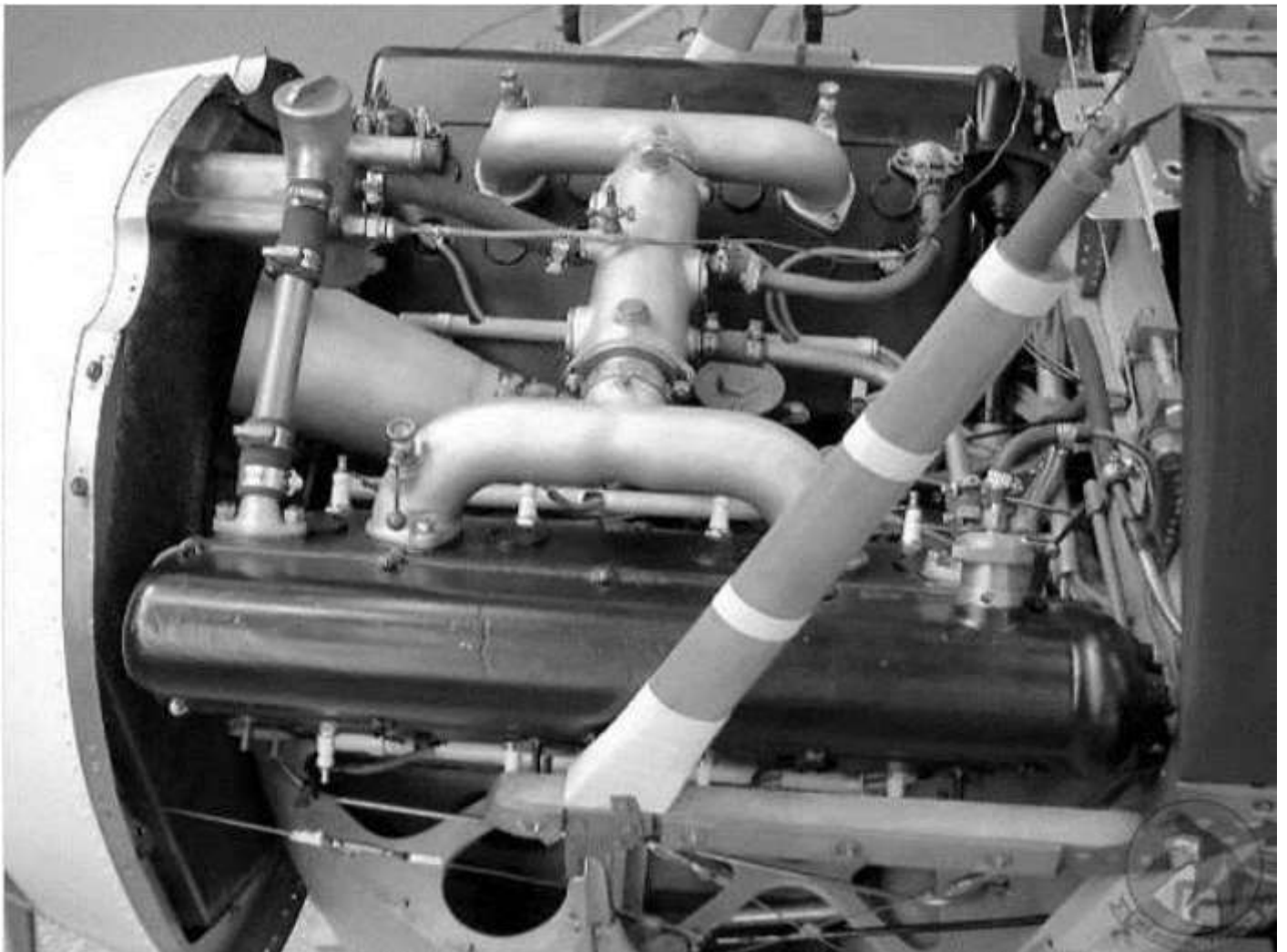
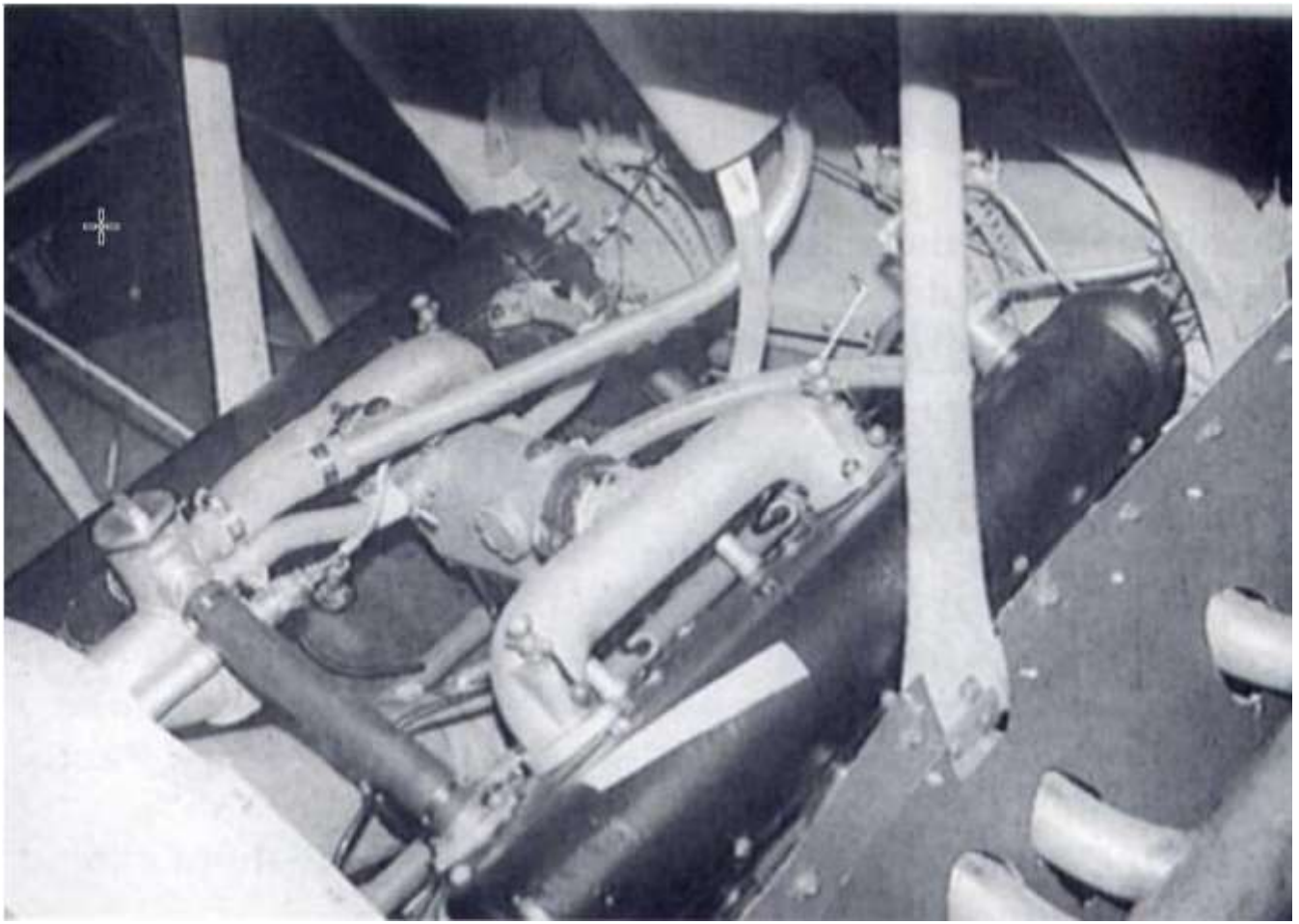

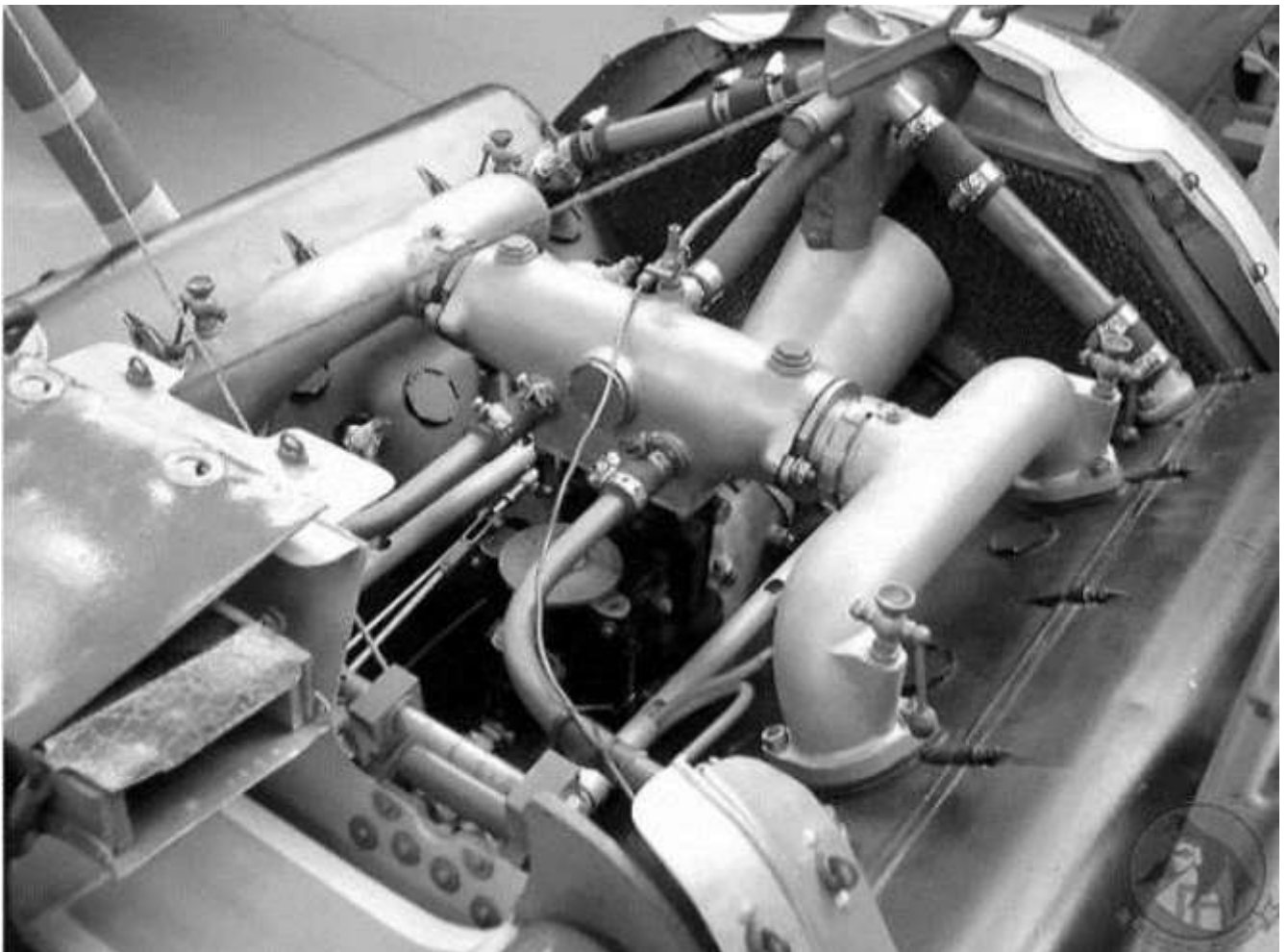
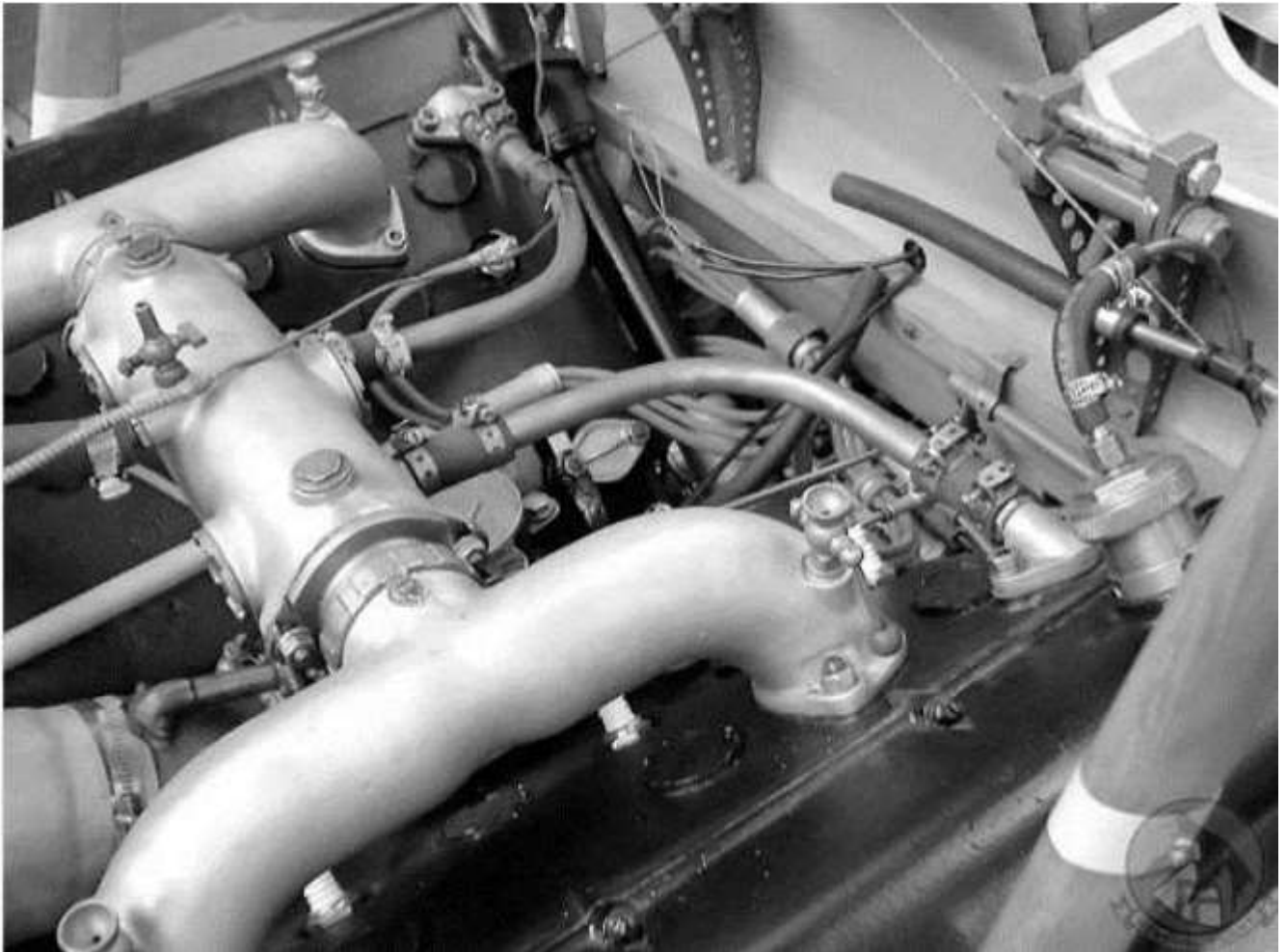

The basic engine has already been modified (in Part 1 of this build log) to fit into the engine bay area of the forward fuselage. This Part 6 covers the detailed changes made to the engine, its assembly and painting.

The detailing items required are:

1. Ignition lead support tubes.
2. Ignition lead connections to both magnetos.
3. Ignition leads.
4. Air intake for the carburettor manifold.
5. Coolant filler and return assembly.
6. Coolant return pipes from manifold and both cylinder blocks.
7. Manifold fuel intake primer valves.
8. Forward external gear oil supply pipes.
9. Forward camshaft external oil supply pipes.
10. Air breather valve and pipe.
11. Radiator/cowl.

NOTE 1: *Refer to the previous photographs and drawings for information.*

NOTE 2: *Some of the Wingnut supplied engine parts are not used as they will not be seen and the modifications carried out to fit the engine do not allow for their fitting.*

NOTE 3: To enable positioning of the engine and parts, it was necessary to temporarily assemble the fuselage halves with the lower wing and rear decking panel (using blue-tack and masking tape).

NOTE 4: The following items will be fitted once the engine has been finally installed into the Fuselage (refer to Part 12 - Construction):

1. Fuel supply pipe connection to carburettor.
2. Coolant supply pipe to filler assembly.
3. Coolant temperatures sensor.
4. Carburettor control.

Engine General:

The engine block was airbrushed with Alclad Grey primer (ALC-302) and when dry given an airbrushed coat of Alclad Aluminium (ALC-101).

Both engine cylinder blocks were airbrushed with Alclad Grey primer (ALC-302) and when dry given an airbrushed coat of MRP Black (MRP-255).

The front faces of both magnetos were brush painted using Tamiya Hull Red (XF9).

The distributor drive shaft casing on the rear of each cylinder bank were brush painted using Mr. Metal Colour Stainless Steel (213) and when dry, buffed with a cotton bud.

Both engine support beams attached to the sides of the engine sump were painted using Tamiya Wooden Deck Tan (XF78) thinned with Tamiya (X20A), then brushed with 'DecoArt Crafters Acrylic' oil paints (Burnt Umber). Refer to Part 2 of this build log for wood effect painting.

Ignition System:

The pre-molded ignition leads support tube between the two magnetos was cut away.

A hole of 0.8 mm diameter was drilled through the tube mounting boss on each magneto.

A cut length of 0.8 mm diameter micro-tube (Albion Alloys MBT08) was inserted through the holes to replicate the support tube.

The tube was 'nicked' (twist with the point of a scalpel blade) in the positions for the two holes used to route the ignition leads to the inner spark plugs of the two cylinder banks.

These 'nicks' were then drilled out to 0.8 mm diameter.

The front face of both magnetos were drilled to accept the eight ignition leads, using a 0.3 mm diameter drill.

The magneto assembly was secured to the rear of the engine.

The ignition leads support tube was brush painted using Tamiya Hull Red (XF9).

The support straps on the ignition leads support tube were brush painted using Humbrol Leather (62).

The spark plugs on both sides of each cylinder bank were brush painted with Tamiya White (X2) mixed with a small amount of Tamiya Buff (XF57).

Four lengths of 0.8 mm diameter micro-tube (Albion Alloys MBT08) were cut to represent the ignition leads support tubes, which on engines of this type were often attached to each side of both cylinder banks.

Eight short lengths of 1.0 mm micro-tube were cut to represent the attachment collars for the ignition tubes (two per tube).

These collars were slid onto the support tubes and positioned to align with the pre-molded 'plates' on the sides of the cylinder blocks (below the spark plugs).

The collars were secured in position using thin CA adhesive.

The four tubes were then given a coat of Tamiya Fine Grey surface primer and once dry, an airbrushed coat of Tamiya Hull Red (XF9).

One tube was attached to a side of each cylinder block and below the row of spark plugs, using thin CA adhesive.

To represent the various ignition leads, lengths of 0.125 mm diameter copper wire were twisted together at one end then secured using thin CA adhesive. Two groups of 8 wires and four groups of 4 wires were created then primed with airbrushed Tamiya Light Grey (XF66) thinned with Tamiya X20A. These were then airbrushed with thinned mix of Tamiya Deck Tan (XF78) and Flat Yellow (XF3).

NOTE: Retain any excess wire cut away from the ignition leads. These will be used for the leads from the support tubes to the spark plugs.

The twisted ends of *each 8 group* of wires were inserted into the ends of the magneto support tube and secured with thin CA adhesive. The free ends of each wire were cut then secured into the previously drilled 0.3 mm holes in the face of the magnetos.

The twisted ends of *two of the 4 groups* of wires were inserted into the previously drilled 0.8 mm holes in the magneto support tube (for the leads to the spark plugs on the inner face of the cylinder blocks) and secured with thin CA adhesive. The free ends of each wire were cut then secured into the end of the inner support tubes on the cylinder blocks.

The twisted ends of *two remaining 4 groups* of wires were secured with thin CA adhesive to the forward side of the magneto support tube, outboard of the tube supports. The free ends of each wire were cut then secured into the end of the outer support tubes on the cylinder blocks.

Using the cut away excess wire, attach each to a spark plug with thin CA adhesive, then loop the wire vertically down and under the support tube and secure in position.

Fuel System:

The fuel manifold (Wingnut Wings engine items E2 and E15) were assembled, but with the forward three pipe assembly cut away. This will be replaced later in the engine build.

Drill a hole of 0.8 mm diameter through item E15. This will be for locating a pipe later in the build. The fuel manifold was primed with Tamiya Fine Grey primer and once dry, brush painted with Mr. Colour Master Stainless Steel (213) and buffed with a cotton bud once dried.

Add the fuel manifold assembly between the cylinder banks.

Engine General (Cont'd):

The engine assembly and fuel manifold were then airbrushed with a sealing coat of Alclad Light Sheen (ALC-311) and allowed to dry.

The engine assembly and fuel manifold were then given a coat of Flory Models Dart Dirt clay wash and allowed to dry, then the bases of the cylinders was given a light wash of the Flory Grey clay wash and allowed to dry.

The Flory washes were removed, as desired, to create the dirt effect on the engine and also the fuel manifold. Refer to Part 3 Weathering for more information).

The engine assembly and fuel manifold were then airbrushed with a light, sealing coat of Alclad Light Sheen (ALC-311) and allowed to dry.

The engine was then further weathered by applying 'AK Interactive' Kerosene Leaks (AL 2039) over the sump area. Tamiya Weathering Master silver from Set C was gently applied to the cylinder blocks and valve gear covers.

Engine components:

Manifold fuel intake primer valves:

To represent the primer valves fitted on each of the four fuel manifold connections to the cylinder heads, the Wingnut fuel manifold has four small 'stubs'.

These were drilled through with a 0.3 mm diameter drill and short lengths of Albion Alloys 0.2 mm Nickel-Silver tube (NSR02) were bent to 90 degrees and secured in the holes using thin CA adhesive. The valves were then painted using Mr. Colour Master Brass (219).

Air breather valve and pipe: The Wingnut air breather valve (item E18) should have a pipe connected to the valve. This pipe was routed to the engine bulkhead, to the outside of the left machine gun support bracket. I decide not to use the kit item but instead drilled out the location with a 1.3 mm diameter drill. Into this hole I inserted a short length of 1.2 mm Albion Alloys brass tube (MBT12) into which was inserted a length of 1.0 mm tube (MBT01) and in this a short length of 0.8 mm tube (MBT2M). A length of 0.5mm tube (MBT05) was annealed with a flame then bent represent the associated pipe, which was inserted into the valve hole and secured in the valve with thin CA adhesive (temporarily .onto the engine bulkhead once the engine is finally fitted.

Coolant filler and return assembly - Coolant return pipes from manifold and both cylinder blocks:

A short length of 1.6 mm diameter tube (MBT06) was drilled through one side only at one end using a 0.8 mm diameter drill (coolant stub pipe). The same drill was used to drill a second hole, through the 1.6 mm tube, just below the first hole (coolant pipe to fuel manifold) and through the 1.6 mm tube at 90 degrees to the first hole (for the two coolant to cylinder block pipes). A length of 0.8 mm tube (MBT2M0 was bent to allow it to be inserted through the 1.6 mm tube and into the previously drilled 0.8 mm hole in the fuel manifold. Ensure the tube extends forward from the 1.6 mm tube, as another pipe needs to fitted onto it (to the radiator header tank).

A 1.0 mm diameter drill was used to drill out the cylinder block locations for the two coolant return pipes (use the pre-molded plate location on the cylinder blocks). Two lengths of 0.8 mm tube (MBT2M) were cut and trimmed to length so as to be able to be inserted into the 1.6 mm tube holes and the cylinder blocks.

Test fit the 1.6 mm tube with the two 0.8 mm cylinder block return tubes and the 0.8 mm fuel manifold tube and adjust as required. Ensure the top of the 1.6 mm tube is above the level of the fuel manifold (the filler cap protruded above the forward decking panel)

Soft solder the pipes together.

Cut short lengths of 1.0 mm tube (MBT01) (to represent the pipe joints) and slide two onto each cylinder block return pipe and two onto the fuel manifold pipe (engine side only). Fit the pipe assembly to the engine and secure using thin CA adhesive. Slide the 1.0 mm 'joint' tubes close the pipe ends and secure in position.

Secure a short length of 0.8 mm tube into the remaining hole (for the stub pipe) and a length of 0.8 mm tube alongside the left of the 1.6 mm tube (for the water temperature sensor).

Cut a small disc from 0.2 mm thick plastic card to make a coolant filler cap and add a very small strip in its centre (hand grip).

The pipes were brush painted with Mr. Colour Master Copper (215), the joints with Tamiya Black (X18) and the filler cap with Mr. Colour Master Brass (219).

Weathering was applied using the Flory Models Dart Dirt clay wash (Refer to Part 3 Weathering for more information).

Air intake for the carburettor manifold: The Spad engine had a hollow funnel attached to the fuel manifold. This funnel diverted warm air from the rear of the radiator to the carburettor air intake.

To represent the funnel a length of sprue was cut with the ends angled, with one end positioned against the manifold and the other end parallel with the rear face of the radiator and just below the coolant filler assembly. The carburettor end was drilled using a 0.8 mm diameter drill and a short length of 0.8 mm Albion Alloys tube (MBT08) was inserted to act as a locating pin. It was then primed using Tamiya Fine Grey primer and when dry, brush painted using Mr. Colour Master Stainless Steel (213). When dry the surface was buffed using a cotton bud.

A 1.0 mm diameter hole was drilled centrally into the round carburettor face on the lower forward side of the fuel manifold. The pin in the funnel was located into the hole, the funnel align correctly then secured in position using thin CA adhesive.

Forward external camshaft oil supply pipes: A camshaft oil drain tube was fitted on the front end of the two cylinder blocks. A small flat was sanded to one side of a length of 1.0 mm tube and the point of a scalpel blade was twisted on the flat (close to the end of the tube) to 'nick' the surface. A 0.8 mm diameter drill was used to drill the 'nick' through one side of the 1.0 mm tube. A length of 0.8 mm tube (MBT08) was soft soldered into the previously drilled hole and at 90 degrees to the 1.0 mm tube, which was then cut to approximately 5 mm in length. A 1.0 mm diameter hole was drilled into the top front of each cylinder block, with the hole being slightly towards the outer edge (not central).

Each pipe was test fitted and the length of the 0.8 mm tubes cut so that the end of the pipe sat in and against the engine block when fitted. The pipes were then primed using Tamiya Fine Grey primer and when dry, brush painted using Mr. Colour Master Stainless Steel (213). When dry the pipes were buffed using a cotton bud. The two pipe were then installed and secured in position using thin CA adhesive.

Forward external gear oil supply pipes: A hole of 0.7mm diameter was drilled inboard of the camshaft oil supply tube connections on both cylinder blocks. A hole of 0.8 mm was drilled into the forward face of the engine sump and centrally below the reduction gear casing. A hole of 0.5 mm diameter was drilled centrally up into the bottom of the reduction gear housing.

A hole of 0.6 mm diameter was drilled through the end of a 0.8 mm tube (MBT08). The tube was cut and inserted into the 0.8 mm hole in the sump. A length of 0.6 mm tube (MBT06) was annealed over a flame then passed through the hole in the 0.8 mm tube. Both sides of this tube were 'formed' around the reduction gear housing and over the camshaft oil supply pipes then up to and into the previously drilled 0.7 mm holes. A short length of 0.6 mm tube was bent to 90 degrees and inserted into the end of the 0.8 mm tube and the previously drilled hole in the reduction gear. Secure the pipes using thin CA adhesive.

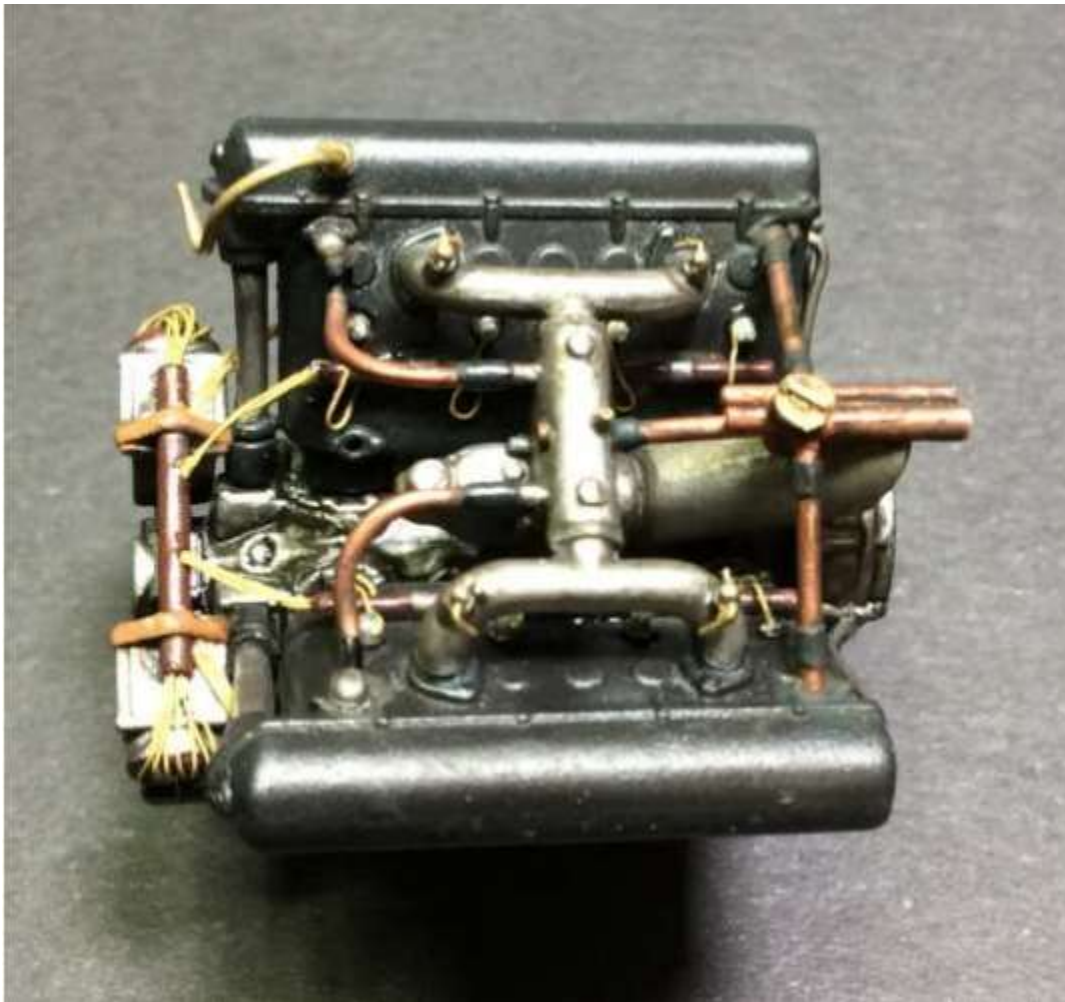

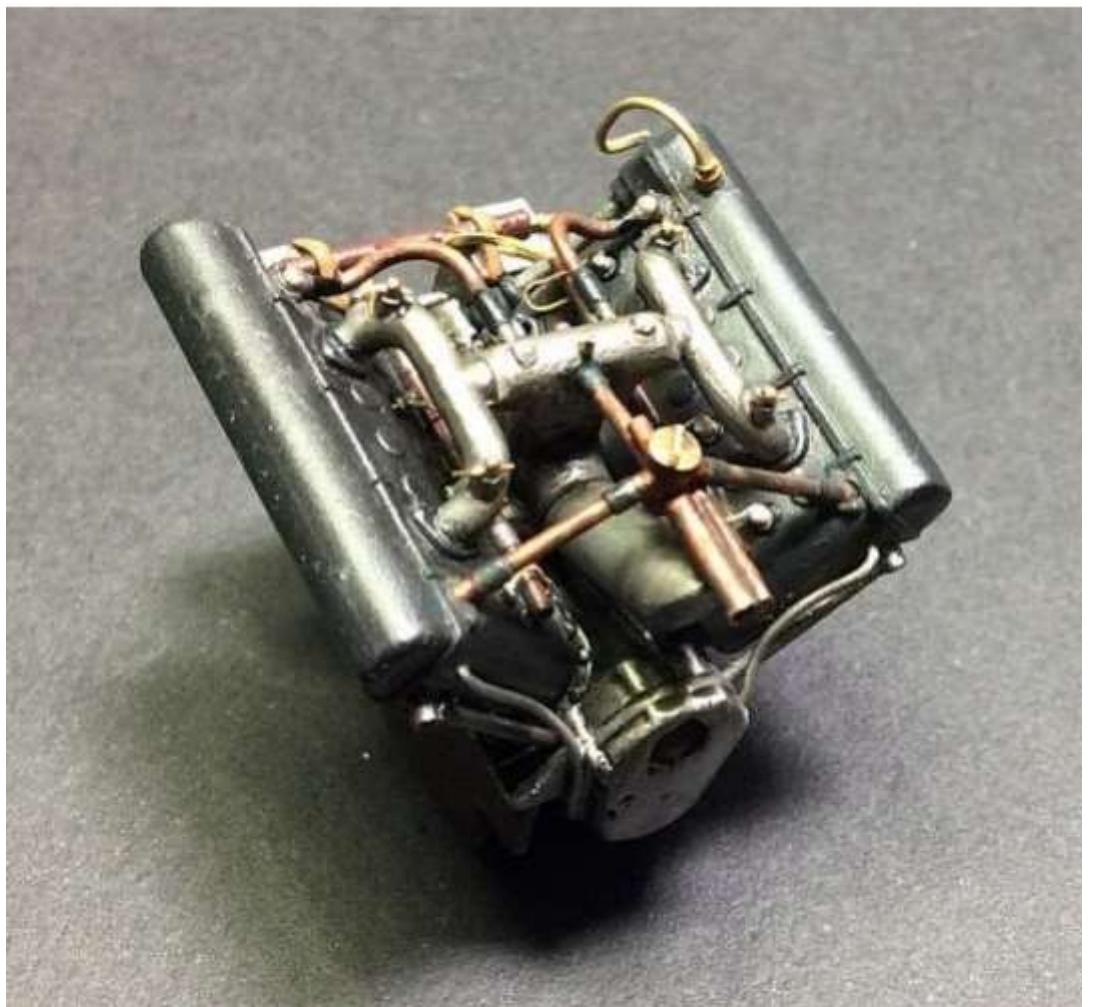



Radiator/Cowl:

The rear face of the 'modified' kit radiator/cowl still has a flat surface with no radiator mesh detail. To represent this I cut the shape of the rear surface from the photo-etch mesh ('RB Productions' radiator mesh RB-T027). This was secured in position using thin CA adhesive around the edge of the mesh the weathered by applying weathered by applying 'AK Interactive' Kerosene Leaks (AL 2039).



PART 6 - WHEELS

The wheels supplied with the kit are the standard sized wheels fitted to production Spad XIII aircraft. However I chose to use the resin 'Aviatic' - 1:32 Spad XIII 65 mm tyre wheels (ATTRES 023)

The wheels were first primed with 'AK Interactive' primer and micro-filler (Grey AK758) then when dry, with Tamiya Rubber Black (XF85). Once this had fully dried I airbrushed Tamiya Deck Tan (XF55) onto the wheel cover on both sides of each wheel.

NOTE: To airbrush the wheel covers of the wheels without over spraying the surrounding tyres, I use a circle drawing tool (Linex 1217 T). I selected the correct size of hole and position the wheel face under the hole, then airbrushed through the hole onto the wheel covers.

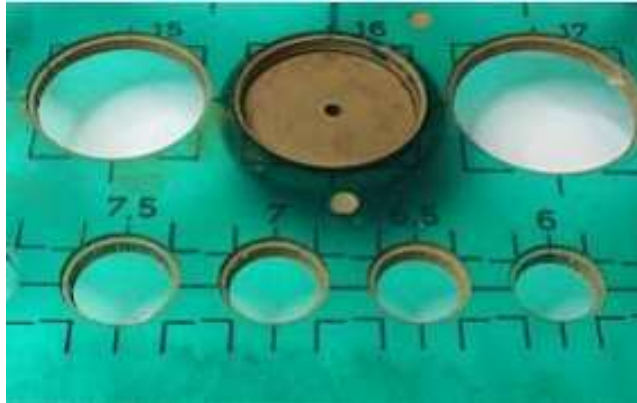

The valve access hole in each wheel cover was brush painted with Tamiya Buff (XF57) and once dry the pre-molded spokes were highlighted with a standard lead pencil.

A wash of 'Flory Models' fine clay wash (Grime) was applied (refer to Part 3 – Weathering) of this build log.

Once the desired weathering effect was achieved, the wheels were given an airbrushed sealing coat of Alclad Light Sheen (ALC311) lacquer.



PART 7 - WEAPONS

The Spad XIII C.1 fighter would normally be armed with either two .303 (7.7 mm) Vickers machine guns or two Marlin M1917/1918 machine guns. However, the shooting down of observation balloons was of great importance and for these missions the Spad could be fitted with one .303 (7.7 mm) Vickers machine gun and one Vickers 11 mm 'Balloon' machine gun. The 'Balloon' gun was a French design requirement and the guns, although Vickers, were converted in America by the Colt Company. Due to the increased size of the ammunition it was found that when fired, the gun would produce heavy vibrations and therefore only one 'Balloon' gun was fitted, the other being the standard gun. It is known that these guns were fitted to some Spad XIII's of the 27th Aero Squadron and as Frank Luke was a noted 'balloon buster', I've assumed he may have had one of these guns fitted to his aircraft.

Painting (applies to both guns):

1. Airbrushed with 'AK Interactive' Primer and micro-filler (Grey - AK758).
2. Airbrushed with 'Alclad' Gun Metal lacquer (ALC-120).
3. 'Sponged' with Tamiya Weathering Master (Set C - Gunmetal).
4. Muzzles 'sponged' Tamiya Weathering Master (Set B - Soot).
5. Breech entry/exit brush painted with mix of Mr Metal Colour Brass (219) and Copper (215).
6. Cocking handles brush painted with Tamia Hull Red (XF9).

Vickers Machine Gun (Hyland Type B)

Vickers 11 mm Balloon Machine Gun



PART 8 - PROPELLER

If you choose to use the kit supplied propeller, there are three ways to create the effect of wood:

1. Painting the kit supplied propeller

The kit supplied propeller can be primed then either hand painted or airbrushed to create a wood effect. To do this effectively can be relatively difficult and a bad propeller can ruin the look of a completed model. A method I use is as follows:

The propeller is first primed then airbrushed with Tamiya Deck Tan (XF78) as a base coat. When dry seal the paint with airbrushed Alclad Light Sheen (ALC311) lacquer. Once fully dry, apply the wood effect (refer to Part 2 – Wood Effects) of this build log. A second seal coat of Alclad is applied and when dry, any decals can be applied. Then a final sealing coat of Alclad is applied and when fully dry, the leading edges and tips of the propeller blades were weathered using a piece of sponge and Tamiya Weathering Master Colour (Sand Set A).

2. Making a propeller from thin wood laminates or coloured paper.

There are various methods described online or in publications for creating handmade propellers. The following cover these methods well:

Wood – [Facebook page of 'Zdenko Bugan' \(Scale Modelling\)](#).

Paper Propeller – <https://forum.largescaleplanes.com/index.php?showtopic=68531>

Painting – Air Modellers Guide to Wingnut Wings (Volumes 1 and 2).

3. Fitting a bespoke handmade wooden propeller.

There are several online companies that make scale wood propellers, but the quality of these can vary. However these do add authenticity to a completed model.

'Copper State Models' – <http://www.copperstatemodels.com/main/productsCS/5/2>

'Eshop Zdarma' – http://wooden-propeller.eshop-zdarma.cz/index.php?category_id=24

'Proper Plane' – <http://properplane.com/>

The engines fitted to the Spad XIII were Hispano-Suiza V-eight 'geared' engines, which had an anti-clockwise rotating propeller. There were at least eight different manufacturers of propellers for this aircraft, most commonly De La Granville, Éclair, Chauviere, Ratmanoff and Regy.

In the following photograph of Frank Luke's 'No.26' Spad, the shape of the propeller is different to that supplied in the kit, which looks to be an Éclair design. From the general shape of the propeller it would seem to be either a De La Granville or Ratmanoff design. The booklet that is supplied with the 'Aviatic' Legend series Frank Luke figure and decal set states the propeller is a 'parchment tipped' De La Granville design.

KIT SUPPLIED PROPELLER





PROPELLER CREATED BY 'PROPER PLANE'

I made enquiries to Richard Andrews at 'Aviatic' and also the 'Wooden Propeller' forum, both of which provided information on this particular propeller design, including dimensions and the type of construction and finish.



For this model I chose the 'De La Grandville' propeller as being closest to the shape of the propeller in the photograph. To best represent this propeller, I asked Alex at 'Proper Plane' to make the propeller, because as yet, I don't have the required skills to make one from laminated wood.



To darken the wood I applied Tamiya Weathering Master (Set D -Oil Stain) across the entire propeller.

The centre hole in the resin propeller back plate was carefully drilled out to 1.8 mm diameter.

The resin front and backing plate supplied with the propeller were carefully cut from the casting block and the backs sanded flat. They were then primed with 'Alclad' primer and micro-filler (ALC-302) and when dry, airbrushed with a light coat of Alclad Duraluminium (ALC-102).

A propeller drive shaft was made using Albion Alloy's micro-tube 1.8 mm diameter (MBT18) and was cut such that when flush with the front face of the propeller and with the backing plate slid onto the shaft, just enough tube protruded from the rear of the propeller to allow it to be inserted into the hole in the engine reduction gear and with the rear of the propeller clear of the radiator cowl.

The propeller was placed with the front face down on a flat surface, to prevent the shaft protruding through the front of the propeller hub.

The propeller backing plate was slid on the shaft and the shaft inserted into the hole in the propeller hub, from the back of the propeller.

The shaft and backing plate were secured in position on the propeller, using CA adhesive. The front propeller plate was then secured to the front of the propeller hub, again using thin CA adhesive.

The shaft of the propeller assembly was then secured into the hole in the engine reduction gear using CA adhesive.

PART 9 - DECALS

The decals applied to this model were the 'Aviatic' Legend Series - Lt. Frank Luke Jnr 27th Aero Squadron (ATTL 01). For this build I used the 'Aviatic' decals (on the right) and used only the instrument decals from the sheet supplied with the model kit (on the left).

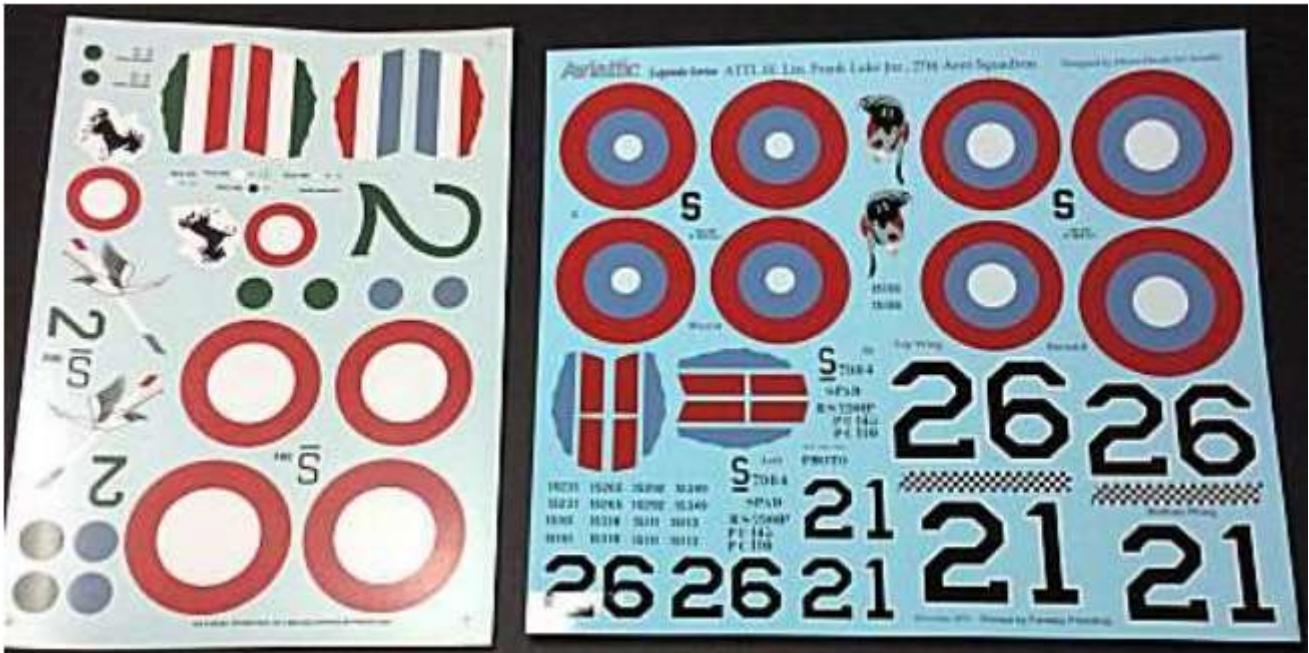

The 'Aviatic' decals are produced by 'Pheon Decals'. There are two variations of the colour blue to choose from, being either French or American. The upper wing roundels needed to be cut for the wings and ailerons, which then had to be aligned not only to the part but also to each other when assembled. Also the rudder white colour is not included so need to be painted beforehand.

First the areas to have decals was airbrushed with Alclad Gloss lacquer, to form a smooth surface and reduce the likelihood of 'silvering' under the applied decals. This is caused by air being trapped in the rough surface of the paint, which after the decal is applied and dries, causes the 'silvering'.

Once dry, the decals were loosened in water and slid into position. Soft tissue paper, such as toilet paper, was used to squeeze out surplus water. Then I applied a coating of 'Micro Sol' setting solution all over the decal, including the parts of the decal standing away from the surface they needed to be tucked around. The setting solution softens the decal and allows it to seat down fully on the surface. After a minute or so the decal can be gently pushed around the edges.

NOTE:

1. As the setting solution softens the decal, care must be taken when touching the decal or damage can be caused.

2. The setting solution causes the surface of the decal to wrinkle, but this is normal and the decal, when dry, will be flat. If there are any visible bubbles under a decal, use a sharp pin to prick the bubble then apply more setting solution.

Then a coat of Alclad Klear Kote Semi-Matte (ALC 312) lacquer was airbrushed over them to merge them with the previously applied lacquer and also to seal them.

Once dry, Flory 'Dark Dirt' clay wash was applied over all decal areas and when dry, gently wiped off to create a subtle weathered effect. A final coat of Alclad Semi-Matte lacquer was then applied to seal the clay washes.

PART 10 - RIGGING (General)

The first thing to check is that you have already drilled out the rigging attachment points. Most models have these located on the model, but it's best to carry out research in reference books or research on line before drilling.

Some modellers use micro drills manufactured for drilling printed circuit boards etc and these drill bits sometimes have identifying coloured collars fitted to the drill shanks. I have found that care needs to be taken when using these drills, as they are sharp and instead of easing their way into the plastic of the model, they tend to bite in and effectively 'cork screw' their way in, which causes jamming and lots of broken drills. This is not only expensive but can leave broken drill bits in the model, which are virtually impossible to extract. An alternative is to use High Speed Steel (HSS) drill bits, which are cheaper and have less 'bite' when in use, although again, they are very fragile and can very easily be broken.

Some modellers drill through the wings etc of the model and rig by pulling through the rigging line/EZ thread etc, gluing in position and then rubbing down the exposed line 'tag' and re-painting that area. I prefer to drill only part way into the plastic and attach the applicable rigging fixture with CA adhesive.

With your research complete and all necessary holes pre-drilled, the rigging can start.

For structural strength I used 'Steelon' mono-filament (fishing line) of 0.12 mm diameter. This is effectively transparent but does give a look of steel, without the need of painting or colouring with a gel pen.

The Spad XIII had rigging for flying controls, internal bracing, external wing and for undercarriage bracing.

NOTE: As you work your way through the rigging it is always good to check the rigging attachment points for any damaged paint. This can be rectified before continuing with the rigging, just in case access will be limited once all of the rigging is completed.

Rudder and Elevator controls cables:

A long length of 0.12 mm diameter 'Steelon' line is inserted into its pre-drilled exit location and secured with thin CA adhesive. An Albion Alloy's micro-tube of either Brass (MBT05) or Nickel-Silver (NST05) is slid onto the line and then the free end of the line was passed through the associated flight control horn and looped back to the free tube. Using two pairs of tweezers, the free end of the line is inserted into the tube and pushed through until the line could be gripped from the other side. Then holding the tube with one pair of tweezers, the free end on the line is gently pulled to tighten the line and cause the free tube to slide up against the control horn etc. Hold the tube in position and apply thin CA adhesive to secure the line and tube in position. Once dry the exposed free end of the line can be cut away, as close to the control horn as possible, using a shielded razor blade.

This method can be used for attaching control cables from rigging holes to control horns etc, and when using after market turnbuckles. For turnbuckles fitted part way along a control cable, the lines and micro-tubes would attach to both ends of the turnbuckle. Where a single end turnbuckle is used, such as directly from the model part, the line and micro-tube would only be attached to the 'loop' end, as the other end of the turnbuckle would be attached to the model part.

Flying, Landing and bracing wires:

The external rigging for this aircraft is quite complex. The list below details the rigging that will be required:

1. Single crossed bracing wires between the outer wing support struts (on each side).
2. Single crossed bracing wires between the top and bottom halves of the inner 'H' wing support struts (on each side).
3. Single crossed bracing wires between the fuselage cabane struts (on each side).
4. Twin flying wires from lower wing root to top of outer wing support struts (a pair forward and rear on each side).
5. Single landing wires from top of fuselage cabane struts to bottom of outer wing support struts (one forward and rear on each side).
6. Twin bracing wires between the top of the forward fuselage cabane strut and the centre of the fuselage decking panel (from each side).
7. Single crossed bracing wires from the top of the forward undercarriage struts to the axle fairing.
8. Single operating 'pull' wire from rip panel on the ventral fuel tank to the top of the right rear undercarriage strut.
9. Single control cable from the rudder control horns to the fuselage (on each side (there were no exposed elevator control cables)).
10. Single bracing wire from tail plane upper surface and over fin.

Specific modifications or scratch building required to allow for this rigging is detailed in Part 1 on this build log.

The rigging will be covered fully in Part12 (Construction) of this build log, but in general, these rigging lines will be attached using a combination of copper wire eyelets, Brass or Nickel-Silver micro-tube, 'Steelon' mono-filament and 'Gaspach' 1:48th scale turnbuckles.

NOTE: The rigging methods that will be used may result in the line being slightly 'slack' and not tensioned enough. This can be resolved by applying heat close to and along the length of the line, which causes the mono-filament line to shrink and then tighten. Heat can be applied from a small soldering iron or similar, but obviously great care is needed, especially to avoid melting the line or touching and damaging the model parts. The exposed micro-tubes can be 'toned down' by applying either a light coat of 'Mr. Metal Colour' Dark Iron (214) or by applying an 'AK Interactive' wash, such as their Leaks and Stains wash.

The following images show where turnbuckles are fitted to the various rigging wires on the aircraft.

●- DENOTES TURNBUCKLE

●T DENOTES TWIN WIRES

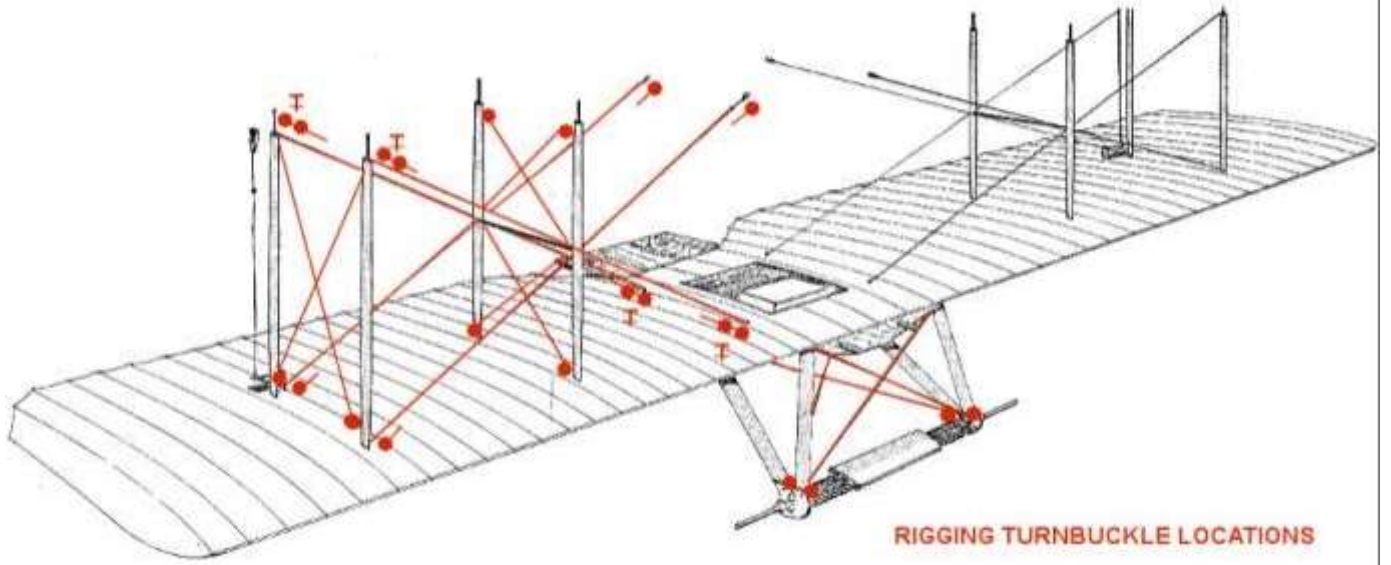

● DENOTES TURNBUCKLE

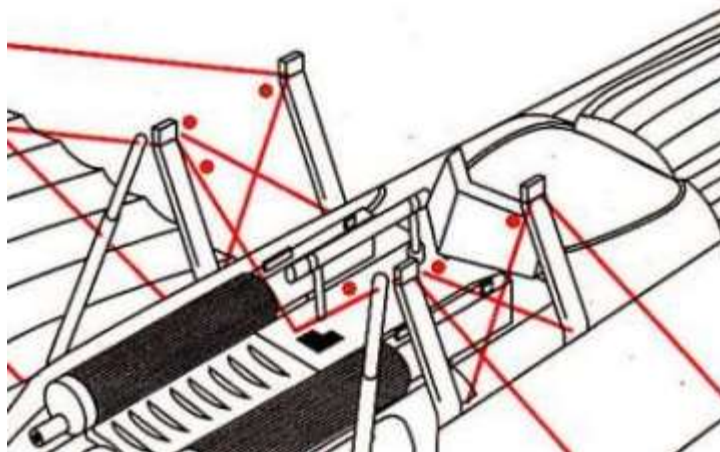

● DENOTES TURNBUCKLES

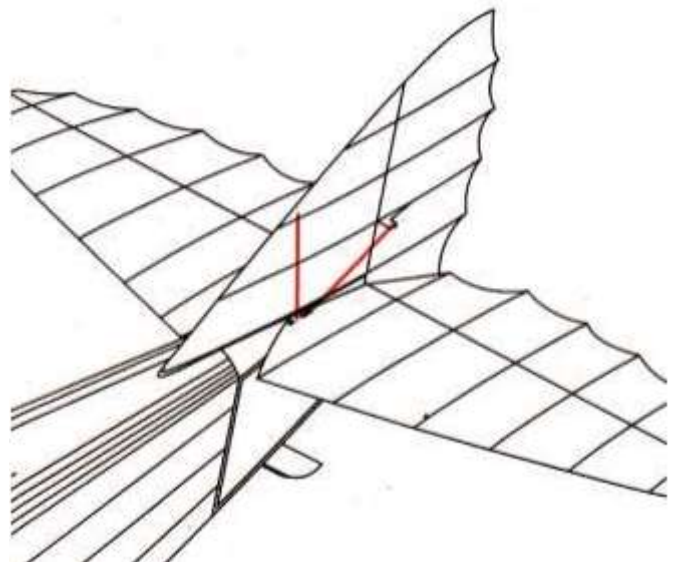
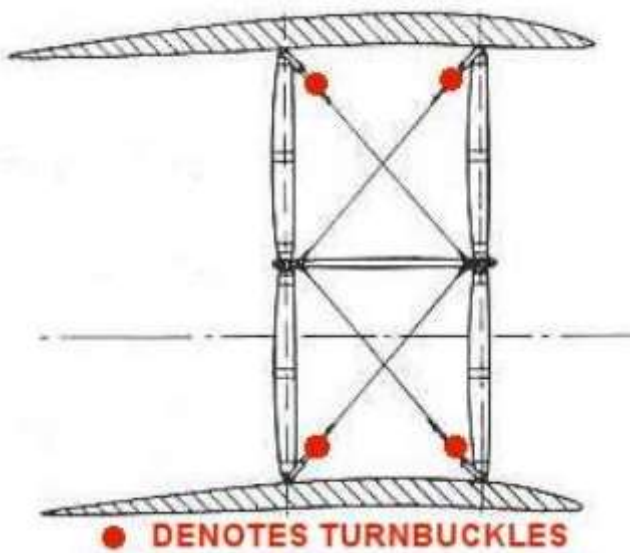
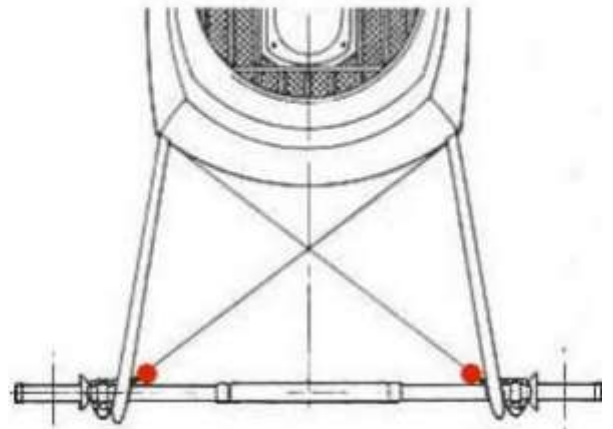

PART 11 - CONSTRUCTION

My basic sequence of construction is as follows, which may not follow the kit instructions.

PART 1 - THE MODEL -Modifications or Corrections:

PART 2 - WOOD EFFECTS

PART 3 - WEATHERING (General)

PART 4 - THE COCKPIT

PART 5 - FUSELAGE INTERNALS

PART 6 - ENGINE

PART 7 - WHEELS

PART 8 - WEAPONS

PART 9 - PROPELLER

PART 12 - CONSTRUCTION (with **PART 10 DECALS & **PART 11** RIGGING)**

PART 13 - FIGURES

PART 14 - DISPLAY BASE

CONSTRUCTION

1. Do Part 1 first, so that you can carry out any required modifications or corrections you want to incorporate into the model.
2. Do Parts 2 through 5, in preparation for closing up the fuselage.
3. Do Parts 6 through 9 in preparation for later in the build.
4. Read Parts 10 and 11 for information.

NOTE: During construction of the model it's prudent to protect the underside of the lower wing, to prevent damaging any detail located there. Tape pieces of scrap sponge either side of the 'ventral tank' area using masking tape.

5. Closing up the fuselage:

Position the cockpit coaming panel on its locating lugs on the left fuselage side, making sure the vertical fuel pipe passes through the pre-drilled hole in the panel.

Apply cement to secure the cockpit coaming panel in position on the left fuselage half.

Temporarily position the right fuselage half and locate the cockpit coaming panel onto its location lugs on the right fuselage half. Hold the fuselage halves together with elastic bands, to keep it secure whilst the cement sets.

Locate the top cockpit frame (created in Part 1 of this build log) into its slot on the rear of the cockpit coaming panel. Ensure the frame fits inside the fuselage halves and is flush to the forward edge.

Apply thin cement to secure the frame to the **left fuselage only**.

Carefully separate the two fuselage halves.

Cut two lengths of 0.3 mm diameter lead wire ('Plus Models') and attach one to each of the two trigger rings on the control column. Loop the wires down and then up behind the vertical panel under the forward edge of the cockpit coaming panel. Secure using thin CA adhesive.

Slide the looped ends of the two pilot's shoulder straps onto the forward cross bar on the right fuselage half and position them in the centre of the bar.

Position the right fuselage half and carefully route the two shoulder straps through the central aperture in the top cockpit frame.

Apply cement to the two fuselage halves and to the location lugs (in the right fuselage half) for the cockpit coaming panel.

Join the fuselage halves, ensuring the cockpit coaming panel sits fully onto its location lugs. Allow the cement to fully set.

Pilot restraint straps:

Carefully pull the two pilot's shoulder straps through the frame, position them onto the pilot's seat then secure in position using 'Fleky 5K CA' adhesive.

Cut to the correct length the remaining cross strap from the 'HGW' set and attach it, using 'Fleky 5K CA' adhesive, between the two shoulder straps (at the pilot's chest height).



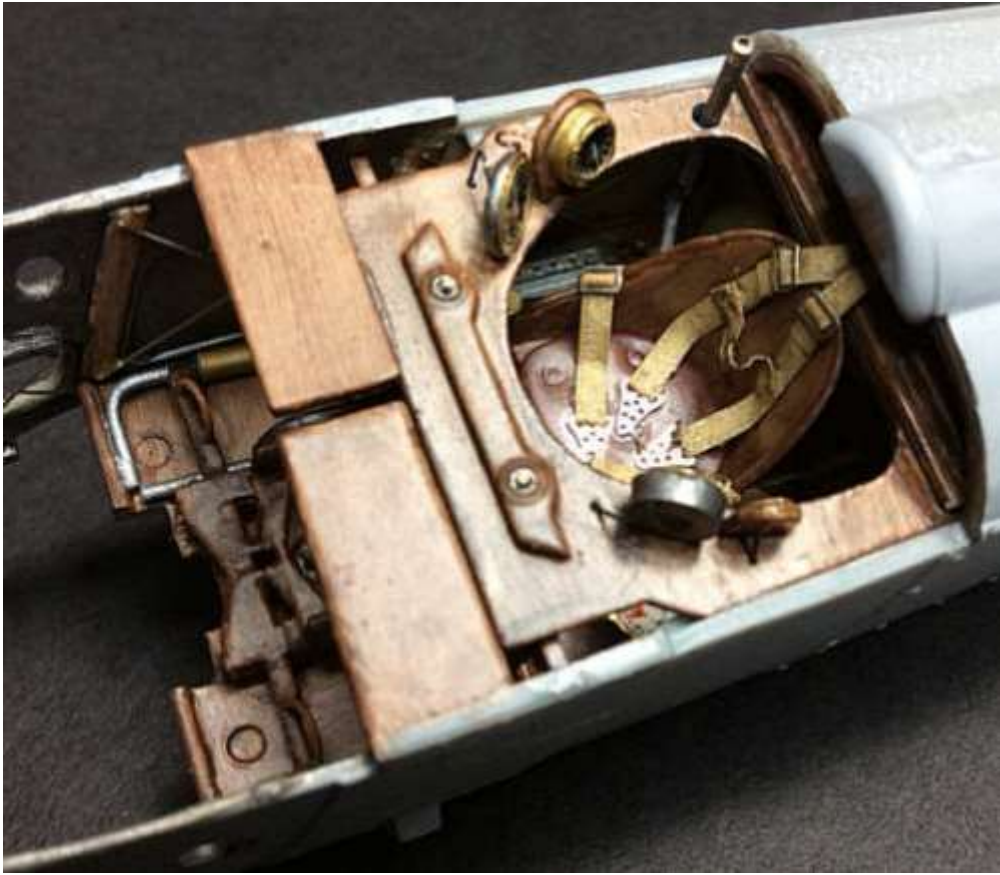

General items:

6. Cement the tail plane/elevator assembly to the rear of the fuselage, including the two tail plane support struts.
7. Cement the lower wing to the fuselage.
8. Cement the lower forward engine panel (louvered) to the fuselage and lower wing forward face.
9. Locate and cement the engine bulkhead into the forward fuselage and up against the vertical Panel on the front of the cockpit decking.



10. Priming: The next stage is to prepare then prime the various parts.

Blank off painted detail (tail skid) and openings (cockpit, engine bay, gun troughs etc), using masking Tape and Bostik 'Blu Tack', UHU 'White Tack' or similar).

Check the surfaces and joints of the assembly and also all of the other kit parts.

If required, apply filler putty to any gaps at joints, surface imperfections etc, using such as 'AV Plastic Putty (401) or 'Perfect Plastic Putty (BD44).

Sand away any imperfections and seam lines.

Clean the parts with a lint free cloth or similar, moistened with Tamiya X20A thinners. This will remove any surface contamination such as finger grease through handling.

Airbrush the surfaces (e.g. 'AK Extreme Primer and Microfiller - AK758).

Once dry re-check the surfaces for any areas that still require attention and apply more filler where necessary.

Repeat the filler then priming until you have no gaps or surface imperfections.



11. Clear Doped Linen (CDL) surfaces: The next stage is to paint the CDL colour scheme for the underside of the two wings, ailerons, tail plane, elevators, fuselage (including the sides under the tail plane), wheel covers, undercarriage struts and axle fairing. In many photographs of the underside of WW1 allied aircraft, the 'outline' of the spars and formers inside the wings could be seen through the doped linen of the wings. How much was dependent on many things, including whether the upper surfaces of the wings were painted or left as CDL. If painted, the visibility through the underside was less, but still apparent. This effect will be incorporated into the painting of the CDL on this model.

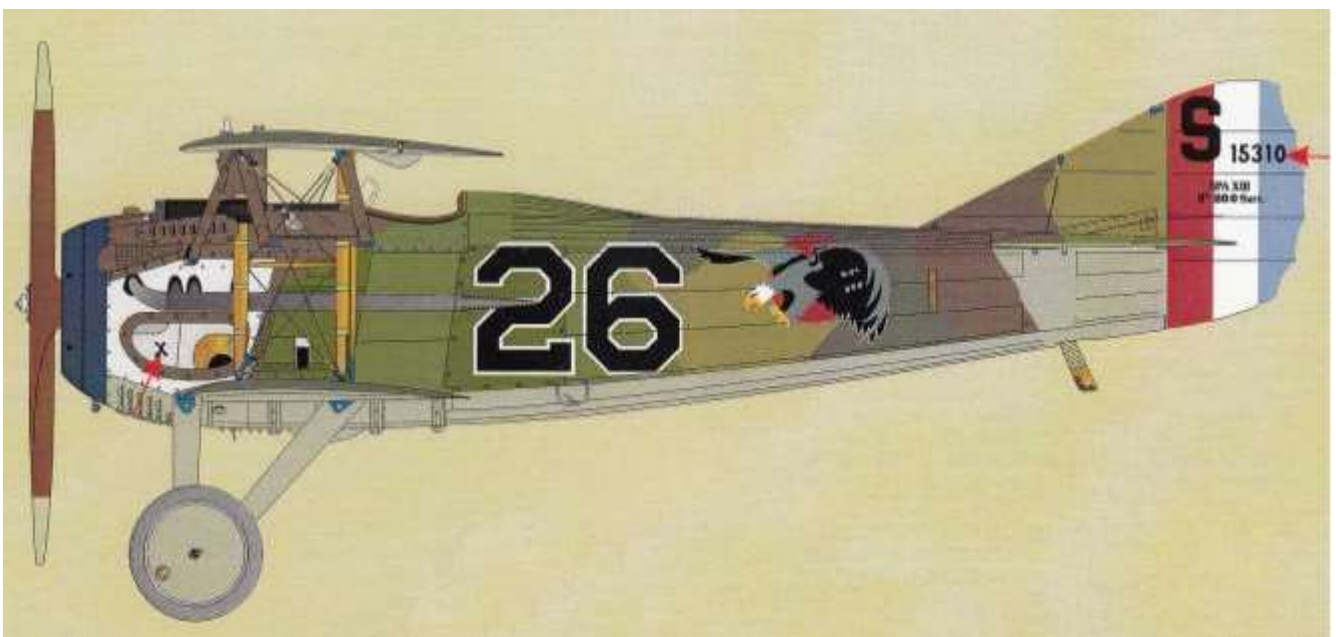

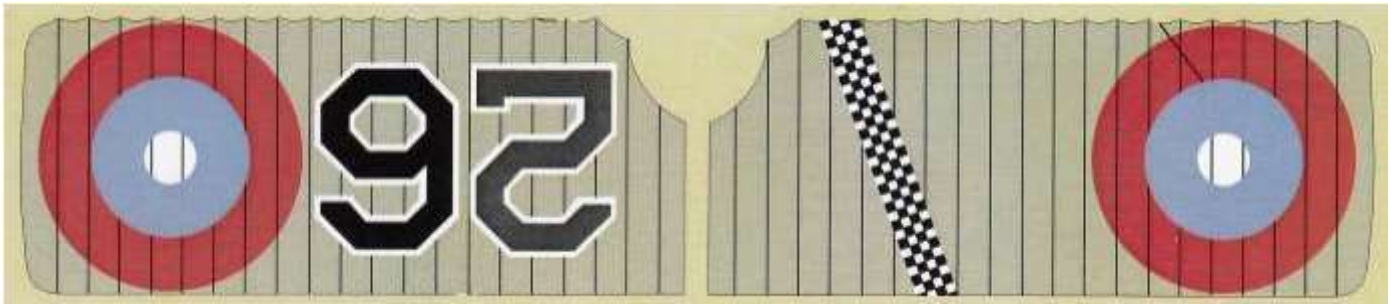

Prime the CDL surfaces, airbrushing with White primer (e.g. 'AK Extreme Primer and Micro filler AK759).

Airbrush the CDL surfaces, at low pressure, with MRP Clear Doped Linen - Bleached (MRP-259).

NOTE: To represent the visible structures through the CDL lined, the outlines of the structure need to be created. Knowledge of what the structure looks like is required and this can be best gained from studying 'cutaway' drawings of the aircraft.

NOTE: The leading edges of both wings, the tail plane and the fin were covered with thin plywood.

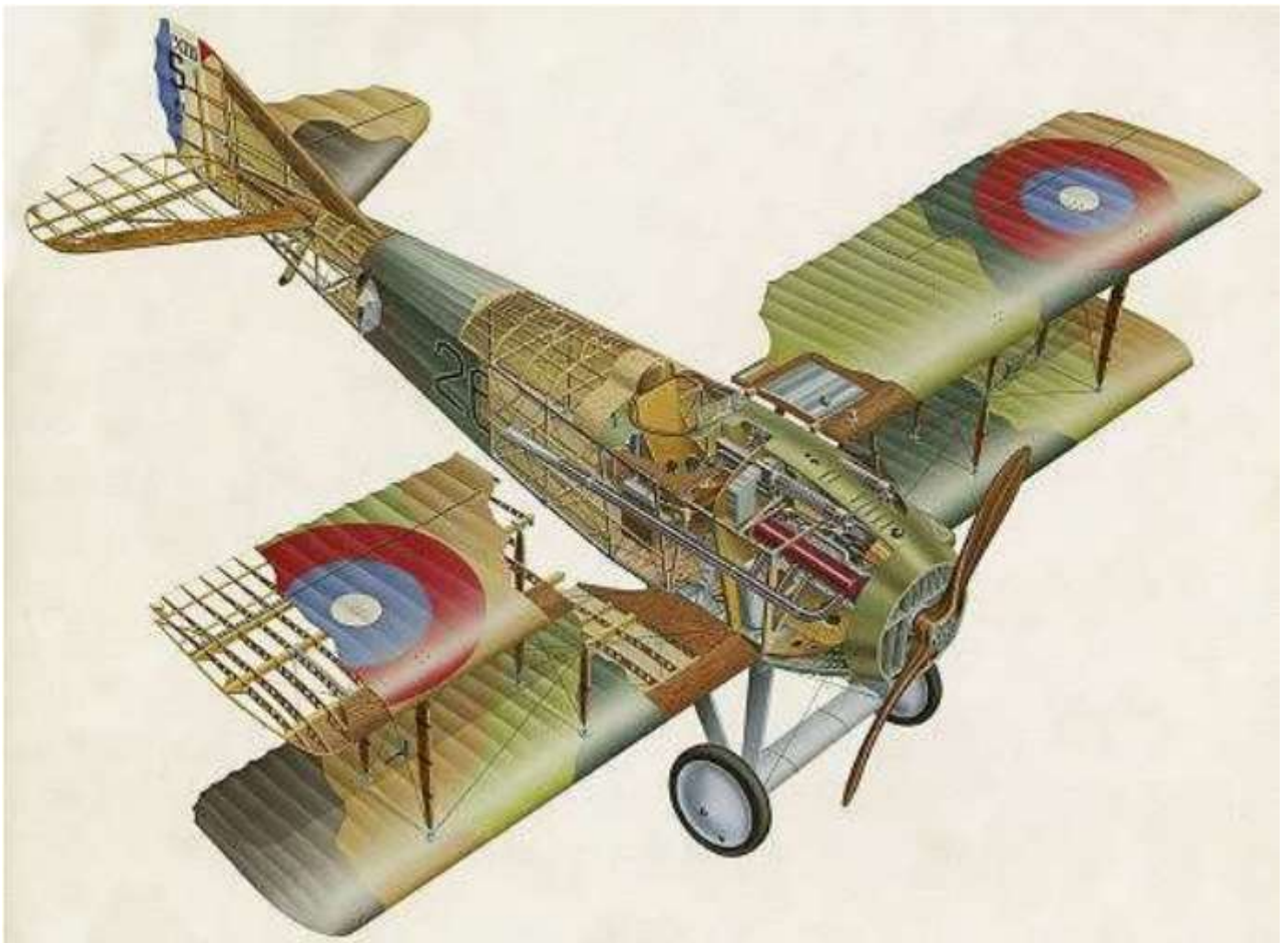

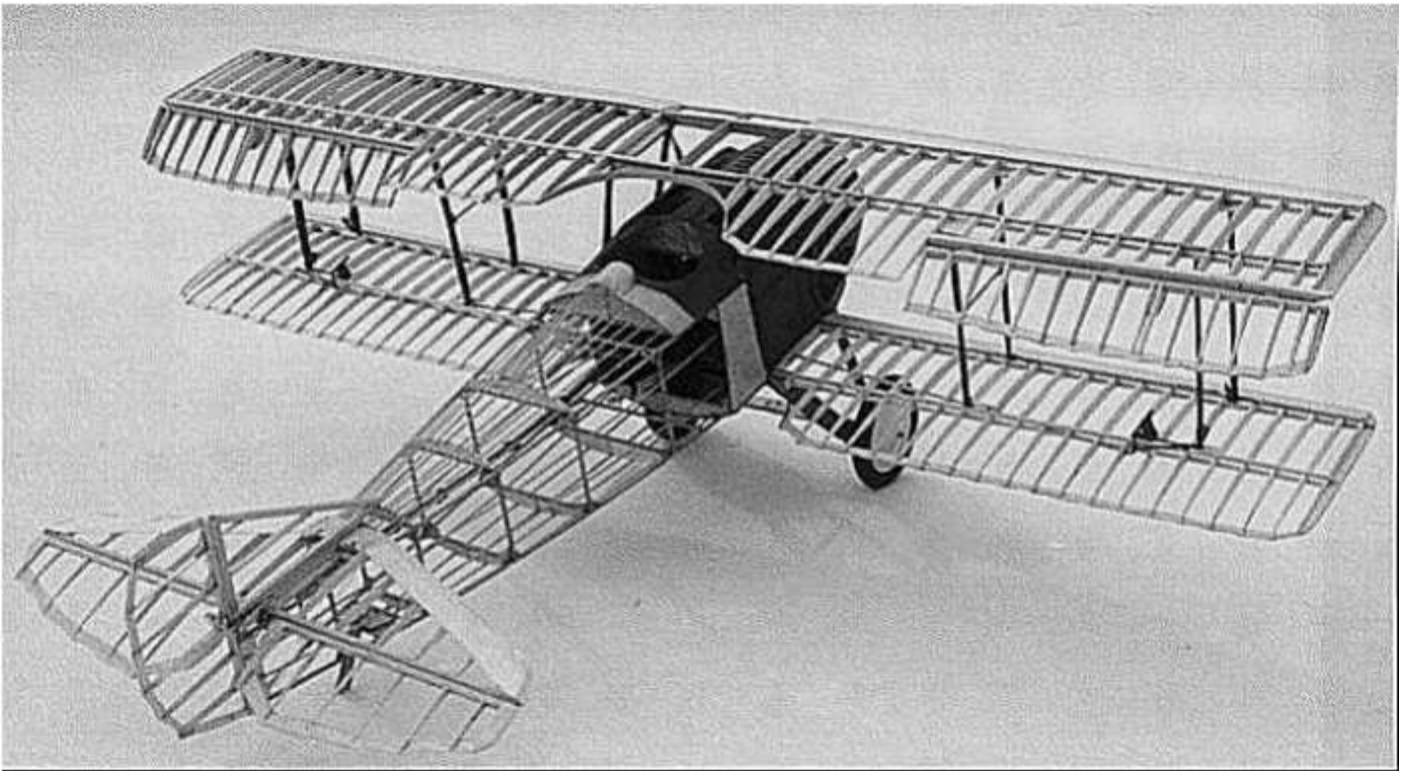
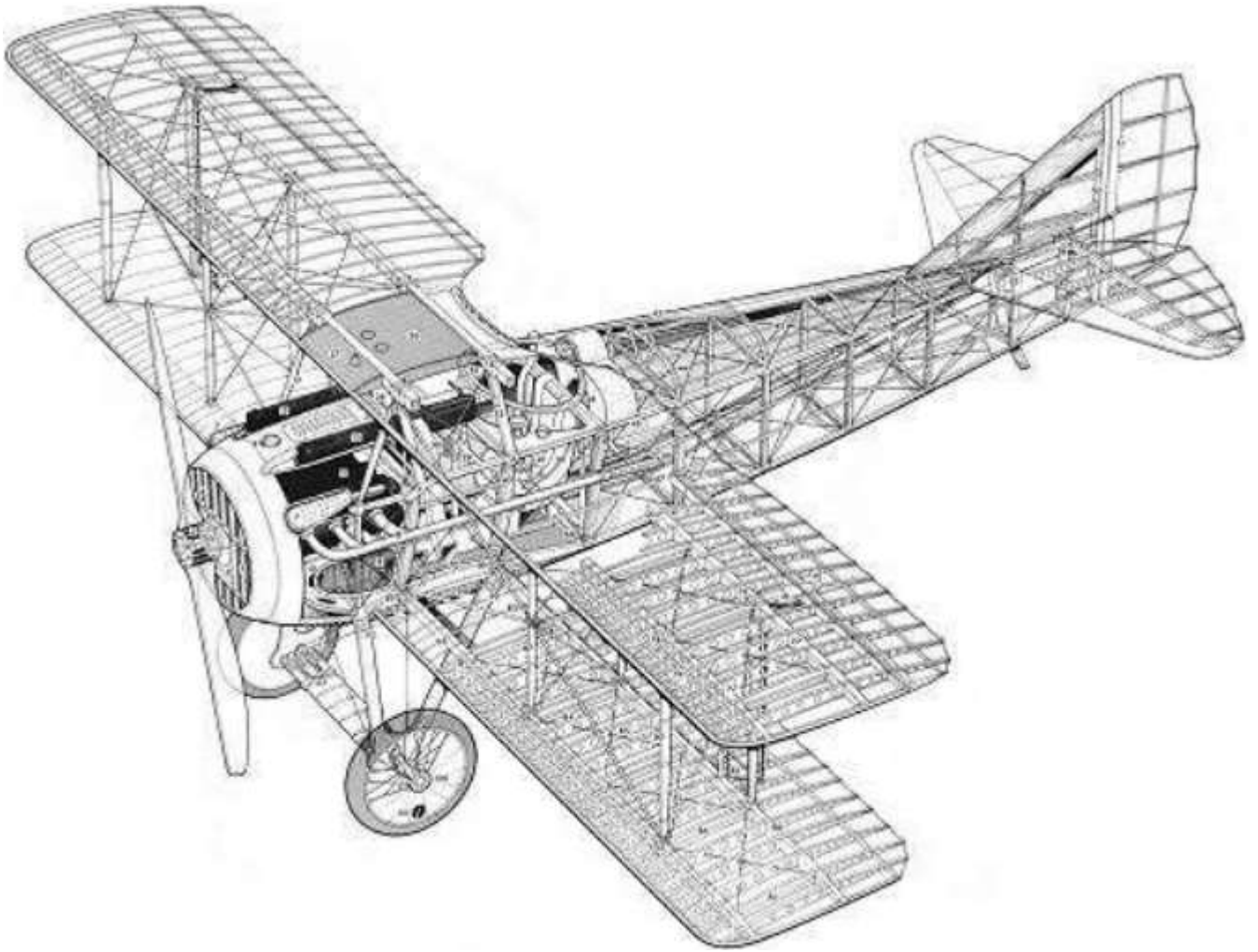

Apply strips of masking tape, of the appropriate width, onto the CDL surfaces to represent the internal structure of the fuselage, two wings, ailerons, tail plane and the elevators. Remember that the leading edges of the wings tail plane were covered in thin plywood and also include the internal cross bracing wires inside the upper and lower wings.

For the internal structure refer to the previous illustrations.

Ensure the masking strips are adhered to the surface as any gaps or lifted tape will allow paint to penetrate under the tape, causing paint 'bleed', which will spoil the effect.

Airbrush the CDL surfaces with light coats of thinned Tamiya Deck Tan (XF55).

Also airbrush the undercarriage struts, wheel covers and the axle fairing.

Carefully remove the masking strips. Remove the masking tape slowly so as to avoid lifting the paint underneath.

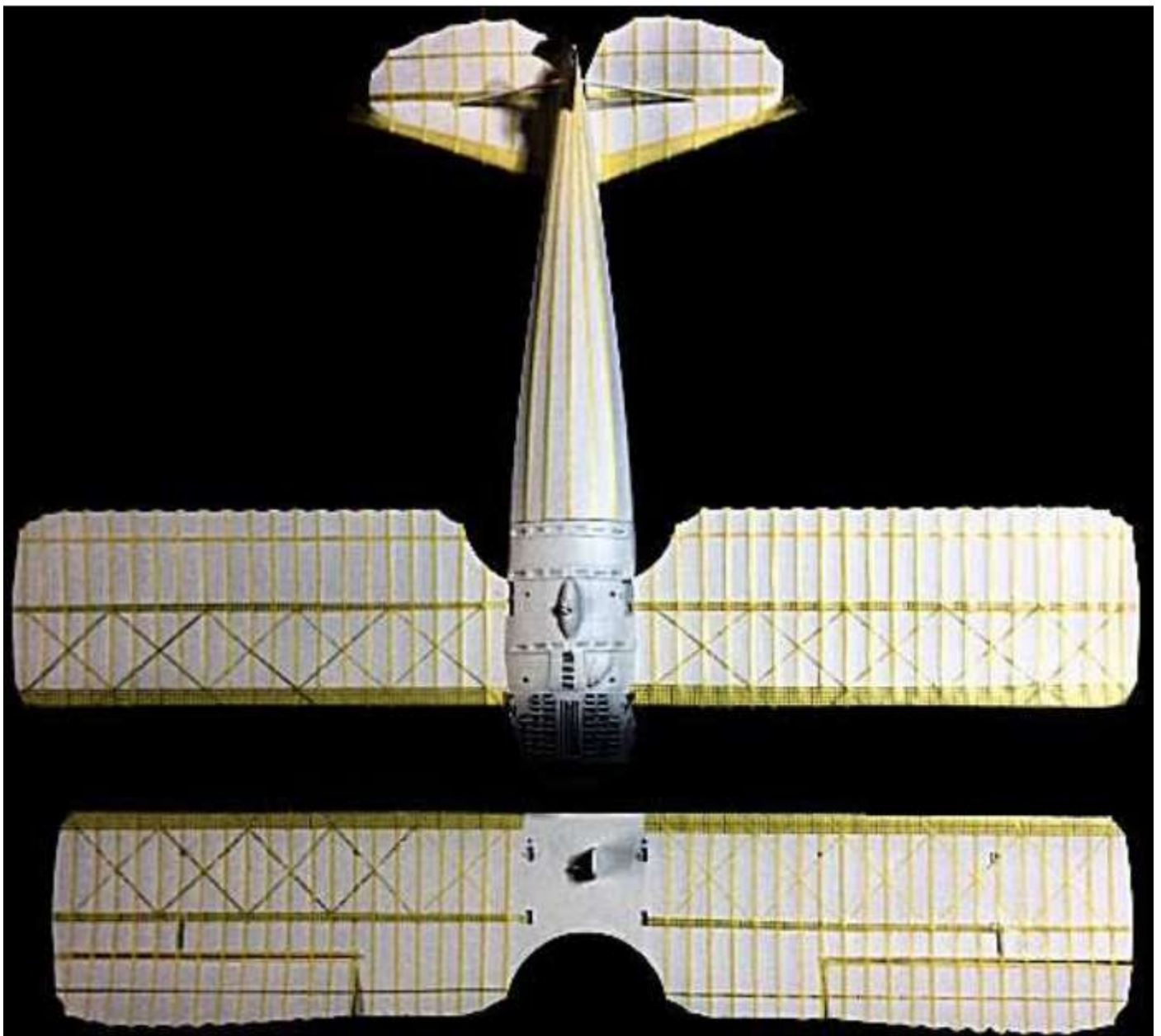

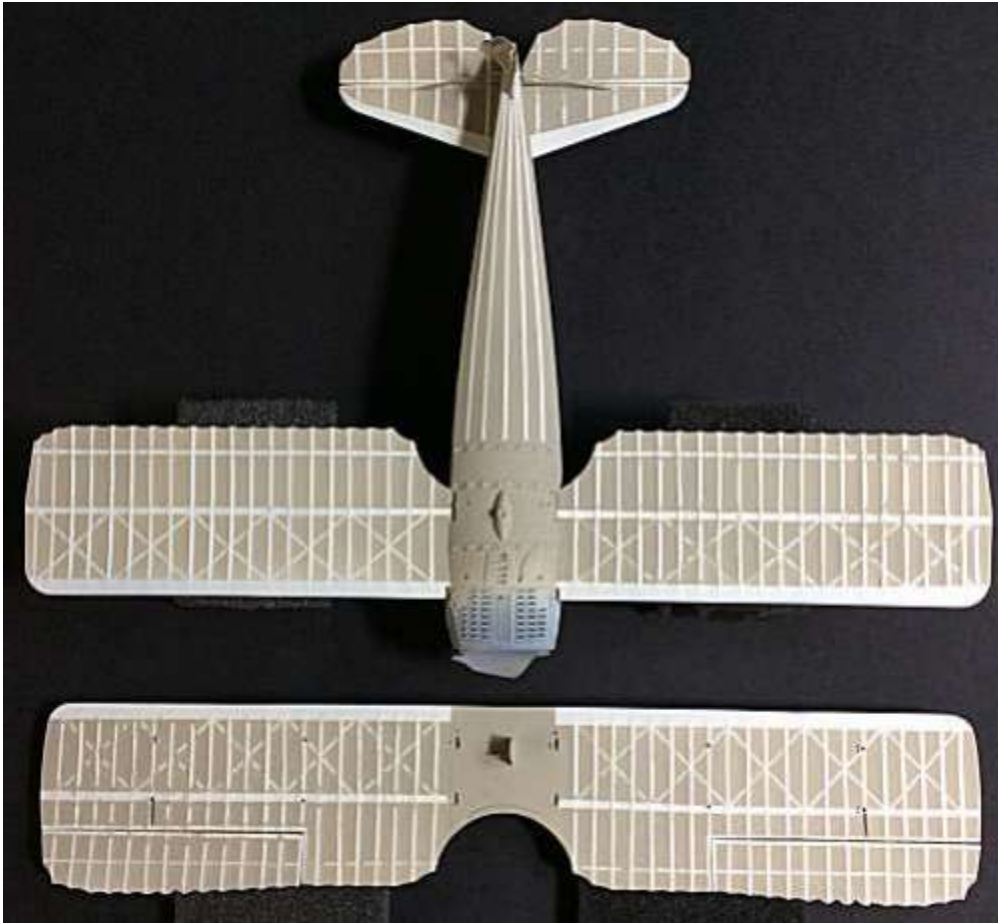

Overspray the CDL surfaces with thinned Tamiya Deck Tan (XF55), to blend and mute the colour of the internal structure. Airbrush light coats and allow the paint to dry between coats. The airbrushed paint will dry darker so applying too much paint at one go will obliterate the internal structure detail.

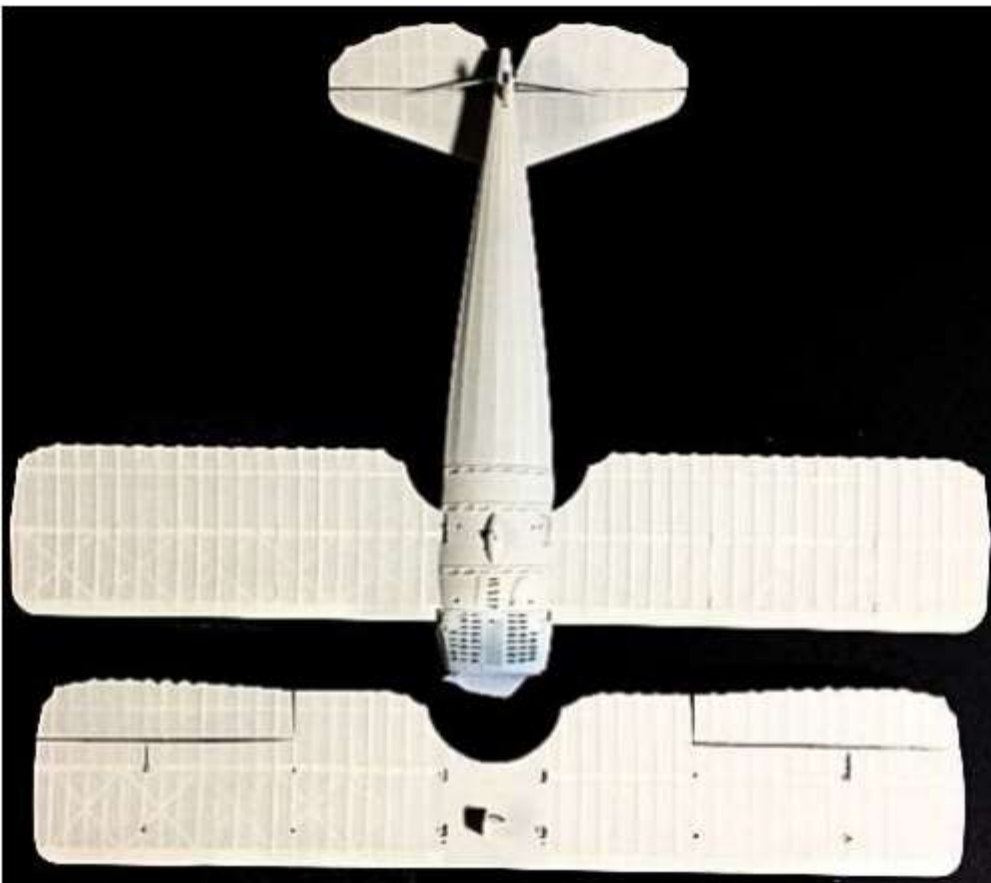

Airbrush a sealing coat of satin (light sheen) sealer, such as Alclad Light Sheen (ALC-311) or Tamiya Semi-Clear (X35).

Once dry, apply a weathering wash of 'Flory Models' Grime clay wash over the CDL surfaces (refer to Part 3 Weathering for more information). Below is a shot of the grime wash immediately after being applied by brush.



Once dry, remove as much of the clay wash as you need to achieve your desired effect. The intention is to 'dirty up' the surfaces, but not to overdo the effect. Remember that grime will accumulate more at joints and other airframe obstructions, such as behind struts. First 'dry brush' the wash away and then, if necessary, use a *very slightly* damp (not wet) tissue or cotton bud to remove more. Wipe away the clay wash in the direction of airflow over the aircraft, that is from front to back, to achieve a more realistic effect.

Once you have achieved the desired effect, airbrush a sealing coat of satin (light sheen) sealer, such as Alclad Light Sheen (ALC-311) or Tamiya Semi-Clear (X35). This will seal the surface and protect the weathered painted surface.

Photographs of Frank Luke Jnr stood by his Spad '26' of the 27th Aero Squadron show evidence of surface dirt and paint chipped surfaces and it looking to be in a fairly 'war weary' condition. Therefore I decided to create this 'dirty' effect with the weathering on the CDL surfaces.



12. Underside details: At this stage the underside details can be added, which comprise:

- Further subtle weathering
- Ventral panel fasteners
- Fuel cap
- Fuel 'rip' panel cable
- Undercarriage cross bracing wires
- Undercarriage struts
- Axle fairing.

Further subtle weathering: To add to the clay wash weathering I used the oil paint 'dot and drag' method to add dirt behind strut attachment points and the elevator pivot points, fuel streaking behind the ventral fuel cap and oil streaking from the engine 'louvered' panels.

Place a small drop of 'Abteilung 502' oil paint (ABT015 Shadow Brown and ABT005 Smoke) onto a piece of card, to allow the oil to leach out of the paint.

After approximately 30 minutes enough of the oil should have leached out to make the paint usable.

Place a small dot of the appropriate colour paint onto the model where the streaking should be located.

Using a soft, small and flat oil brush, drag the paint in the desired direction.

Dip a second brush into Tamiya X20 Enamel thinners then dab onto a tissue to remove most of the thinners.

Drag the brush along the oil paint streak to gently remove as much as is required. Ensure you regularly wipe the brush to prevent build up of paint.

Ventral tank fasteners: The ventral tank was supported by perforated metal straps across the fuselage and tank. However it appears there were also four 'fasteners. To represent these fasteners, four short lengths of 0.4mm diameter Nickel-Silver tube (Albion Alloys NST04) were cut and inserted into 0.4 mm diameter holes drilled through the pre-molded locations. An 'RB Motion' 0.79 mm Aluminium nut (1281-A) was located onto each tube then secured using thin CA adhesive.



Fuel cap: The ventral tank fuel cap, created in Part 1 of this build log, was brush painted with Mr. Colour Master Brass (219) and stained using 'AK Interactive' Oil (AK 2019).

Fuel 'rip' panel cable: The fuel rip panel and hole for the operating cable were created in Part 1 of this build log. To represent the operating cable:

A length of 0.12 mm diameter 'Steelon' mono-filament was secured into the pre-drilled hole adjacent to the rear right undercarriage strut.

The line was then passed through a short length of 0.5 mm diameter tube (Albion Alloys MBT05) then through the rip panel loop and back through the tube.

The line was pulled to tighten then secured at the tube using thin CA adhesive.

Undercarriage cross bracing wires: The four cable 'anchor' eyelets in the fuselage and the axle fairing were created in Part 1 of this build log.

Eight lengths of 0.12 mm diameter 'Steelon' mono-filament were cut.

A short length of 0.5 mm diameter tube (Albion Alloys MBT05) was cut and slid onto a line, which was then passed through the end loop of a 'Gaspatch' 1/48th scale turnbuckle, then looped back through the tube. **The line should be left loose at this stage.**

Repeat this to have two lines attached to each side of the four 'Gaspatch' turnbuckles.

Undercarriage struts: The two undercarriage struts were primed then airbrushed with Tamiya Deck Tan (XF55). The attachment brackets were brush painted with a mix of Tamiya Flat Blue (XF8) and White (X2) to 60%-40% ratio. Once dry, airbrush a sealing coat of satin (light sheen) sealer, such as Alclad Light Sheen (ALC-311) or Tamiya Semi-Clear (X35).

After this they were weathered using 'Flory Models' Grime clay wash and once dry, sealed again with an airbrushed coat of Alclad :Light Sheen (ALC-311)

Axle fairing: The axle fairing was primed then airbrushed with Tamiya Deck Tan (XF55). The ends of the axle support tubes were brush painted with Mr. Metal Stainless Steel (213) and the suspension bungee cords with Tamiya Dark Yellow (XF60). Once dry, airbrush a sealing coat of satin (light sheen) sealer, such as Alclad Light Sheen (ALC-311) or Tamiya Semi-Clear (X35).

After this it was weathered using 'Flory Models' Grime clay wash and once dry, sealed with an airbrushed coat of Alclad :Light Sheen (ALC-311).

Undercarriage assembly:

Assembly:

Insert the locating pins of each undercarriage strut into the pre-drilled holes in the fuselage locations, using 'Fleky 5K' CA adhesive, which gives time to align the struts to the axle fairing.

Cement the axle fairing to the struts.

Once set, reinforce the strut to fuselage joints and axle fairing with cement.

Rigging:

A short length of 0.5 mm diameter tube (Albion Alloys MBT05) was cut and slid onto one turnbuckle line, which was then passed through a fuselage anchor then looped back through the tube. **The line should be left loose at this stage.**

Repeat this for the other turnbuckle lines at the fuselage anchors.

Repeat this, but at the four lines for the axle fairing. **The lines should be left loose at this stage.**

For each axle fairing line, ensure the two tubes are positioned such that the turnbuckle is closer to the axle fairing, then pull the free end of the line closest to the axle fairing to tighten and secure using thin CA adhesive.

Repeat this for the other turnbuckle lines for the axle fairing.

Repeat this for the four turnbuckle lines for the fuselage anchors.

At each turnbuckle, pull the free ends of the two remaining lines to tighten with the tubes close the turnbuckle ends.

Ensure all four turnbuckle lines are tight, then secure the turnbuckle tubes on each line with thin CA adhesive

Cut away the exposed tags of line at each tube.

Brush paint the centre of each turnbuckle with Mr. Colour Master Brass (219).

Brush lightly the brass micro-tubes on the rigging lines using stained using 'AK Interactive' Kerosene Leaks (AK 2039).



13. Camouflage colour scheme: The next stage is to paint the camouflage colour scheme to the upper surfaces of two wings and tail plane, the fuselage and the fin. Although the colour scheme illustrated in the 'Aviatic' Legend Series ATT01 - Frank Luke Jnr booklet is good, I chose to use the illustration from 'Osprey - Aircraft of the Aces' - SPAD XII/XIII Aces of World War 1 by Jon Guttman, as the colour delineation is more obvious.

A point to note is that some sources state the wheel covers were the blue and white scheme shown in the side profile. However other sources suggest this was a misconception based on shadows on the original black and white photographs, which were mistaken for the pattern. I've chosen not to include this wheel cover, but instead to have them in plain CDL finish.

The Spad employed a five colour scheme, namely Dark Green, Light Green, Beige, Brown and Black. The different manufacturers of the Spad aircraft each had slight variations to the Spad recommended patterns, but all were based on the Spad design. The aircraft modelled was built by 'Bleriot' and the colour scheme is the version employed by that company.

The colours for this scheme were as follows:

Light Green:- Tamiya Cockpit Green (XF71) lightened with White (X2).

Dark Green:- Tamiya Dark Green 2 (XF70) with small amounts of White (X2) and Black (X1).

Black:- Tamiya NATO Black (XF69).

Brown:- Tamiya NATO Brown (XF68) lightened with White (X2).

Beige:- Tamiya Dark Yellow (XF60).

Left forward fuselage - Mr. Colour Stainless Steel (MC213)

NOTE: As the camouflage has defined edges I decided to brush paint all of the colours except the Light Green, which was airbrushed first. Each colour mix was appropriately thinned with Mr. Colour Levelling Thinners.

Before painting and to protect the CDL underside painted surfaces, the underside edges of the wings, tailplane, fuselage and undercarriage were masked off.

14. Once the painting was completed I removed all of the masking tape.

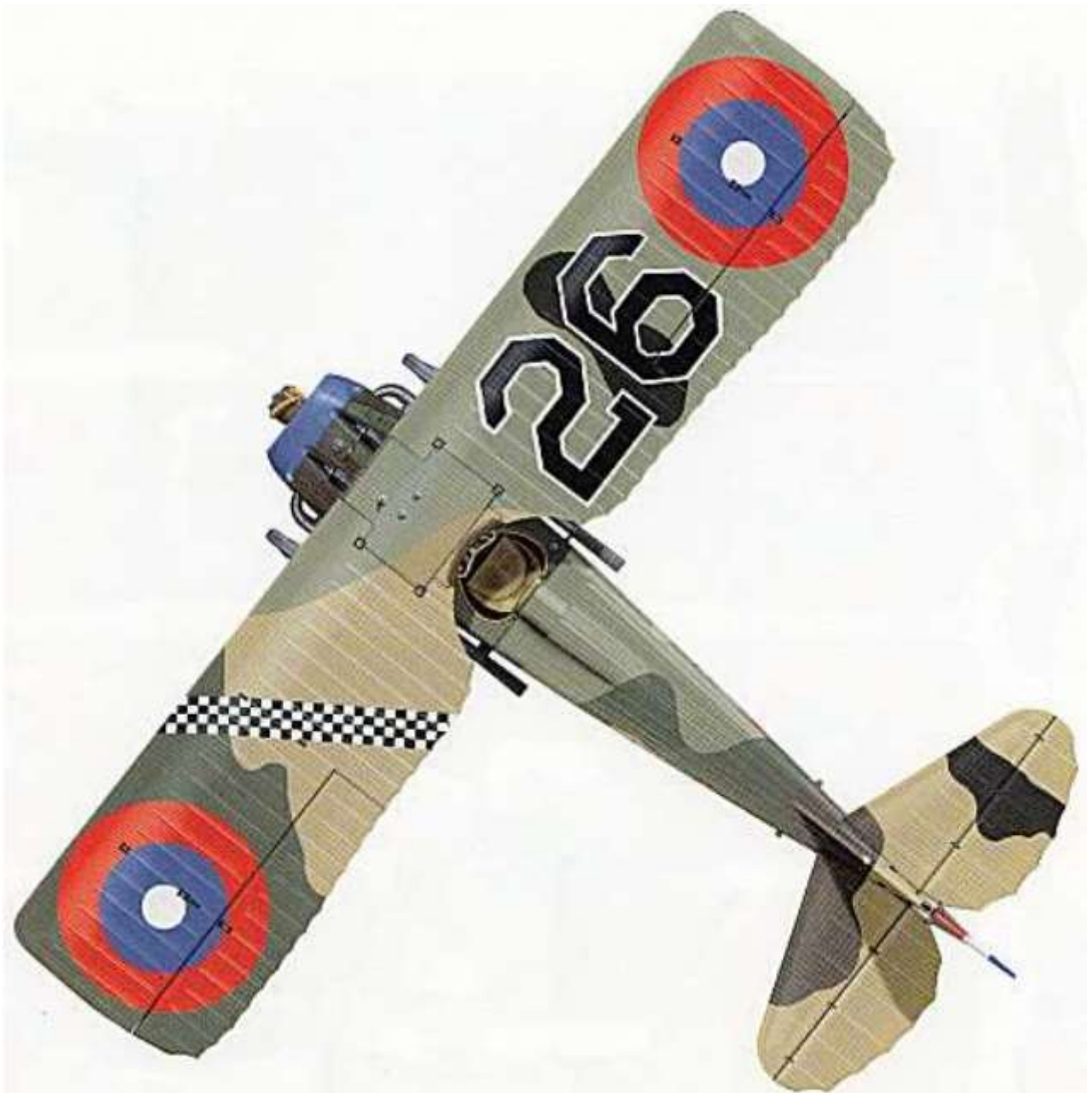

15. The cockpit edging and head rest were brush painted with 'AK Interactive' Brown Leather (AK-3031).
16. The three caps on the centre section of the upper wing were painted with Mr. Colour Brass (219) and Stainless Steel (213).
17. Airbrush a sealing coat of satin (light sheen) sealer, such as Alclad Light Sheen (ALC-311) or Tamiya Semi-Clear (X35), over the painted surfaces (to seal the paint for weathering).
18. Once dry, apply a weathering wash of 'Flory Models' Grime clay wash over the camouflaged surfaces (refer to Part 3 Weathering for more information).
19. Once dry, remove as much of the clay wash as you need to achieve your desired effect. The intention is to 'dirty up' the surfaces, but not to overdo the effect. Remember that grime will accumulate more at joints and other airframe obstructions, such as behind struts. First 'dry brush' the wash away and then, if necessary, use a *very slightly* damp (not wet) tissue or cotton bud to remove more. Wipe away the clay wash in the direction of airflow over the aircraft, that is from front to back, to achieve a more realistic effect.
20. Once you have achieved the desired effect, airbrush a sealing coat of satin (light sheen) sealer, such as Alclad Light Sheen (ALC-311) or Tamiya Semi-Clear (X35). This will seal the surface and protect the weathered painted surface.
21. Airbrush a sealing coat of Tamiya Clear (X20A) thinned with Mr. Colour self levelling thinners (400) where the decals will be located (as a base coat for applying the decals).

Decals:

22. Apply the decals from the 'Aviatic' Legend Series - Lt. Frank Luke Jnr 27th Aero 24 Squadron (ATTL 01) to the two wings and fuselage sides.

NOTE: I found these decals to be more difficult to apply than most, possibly due to the fact they are a limited run of 150 only. They seemed to be thicker than most and did not readily conform to the surface detail or react to decal setting solutions such as Micro-Set, Micro-Sol or 'Daco Products' heavy solution. On some I even resorted to using Tamiya X20A thinners after perforating the decal surface to allow the solution to 'get underneath'. Also I found that a few of the decals either split whilst manoeuvring them into position or cracked around raised surface detail. However as the only decals available for this aircraft and in this scale, they had to be used.

NOTE: There is speculation over the colour of the inner ring of the roundels (cockades) of this particular aircraft. Some sources have it as French light blue and others as over painted with USAS blue. The information from the 'Aviatic' set suppose that the USAS blue colour used for the engine cowl (C Flight) could have been the same used for over painting the roundels. I chose to use the optional USAS coloured rings, but first had to remove the pre-molded wing strut attachment plates in those areas, otherwise the decals would not conform to the surface.

23. Apply matched coloured paint, by brush, over any defects in the decals (cracks, splits etc).

General items:

24. The rudder was airbrushed with 'AK Interactive' White primer and micro-filler (AK759) and when dry, masked off for the centre white stripe. The red stripe was brush painted with Tamiya Flat Red (XF7) thinned with X20A, and the blue with thinned Flat Blue (XF8). A small amount of Tamiya Rubber Black (XF85) was added to both colours to darken them slightly.
25. An airbrushed sealing coat of Alclad Light Sheen (ALC-311) mixed with Flat (ALC-314) (75%-25%) was applied over the decals and painted rudder.
26. To add final weathering, apply a weathering wash of 'Flory Models' Grime clay wash over the applied decals (refer to Part 3 Weathering for more information).
27. An airbrushed sealing coat of Alclad Light Sheen (ALC-311) mixed with Flat (ALC-314) (75%-25%) was applied over the decals.
28. The bottom edge of the fuselage sides were 'sponged' with Tamiya Weathering Master (Set A - Mud).
29. The 'mesh' grills for the fuselage lower forward access panels were secured in position using thin CA adhesive then brushed over with 'Flory Models' Grime clay wash to flatten the metallic glare.
30. The engine assembly was cemented in the engine bay, ensuring it was fully back and seated correctly to allow flush fitting of the radiator/cowl to the forward fuselage.
31. The rudder was located onto its locating pins in the fin and secured in position using thin CA adhesive.





32. The front face of the radiator and cooling flaps was airbrushed 'Alclad' Aluminium (ALC-101). The cowl was airbrushed with Tamiya Flat Blue (XF8) with a small amount of Tamiya Rubber Black (XF85) to darken it slightly.
33. Once dry a wash of 'Flory Models' Dark Dirt clay wash over the front face of the radiator, the cooling flaps and the inner, rear face of the radiator (refer to Part 3 Weathering for more information).
34. The engine radiator/cowl was cemented onto the front of the fuselage.
35. The two machine guns were located in position with a 0.4 mm diameter micro-tube (Albion Alloys MBT04) pivot 'pin', inserted through the holes in the support brackets and gun mounts.
NOTE: The 'Balloon gun' is located in the right gun trough. The standard .303 gun in the left trough.
36. Fit the gun sight bar into the two holes in the front of each barrel and align the bar and guns.

37. Apply thin CA adhesive to the gun pivot pins and the gun sight bar to lock them in position.
38. Paint the gun sight cross bar Tamiya NATO Black (XF69).
39. Squadrons were normally split into Flights (e.g. A, B and C Flight) and many used different coloured markings on the aircraft to denote which Flight it belonged to. The blue coloured engine cowl for this model is thought to denote 'C' Flight. The cowl was brush painted with Tamiya Flat Blue (XF8) and a small amount of Tamiya Rubber Black (XF85) thinned with Tamiya X20A.
40. The radiator drain valve at the bottom of the engine cowl was brush painted with Mr Metal Colour Brass (219).
41. A light airbrushed sealing coat of Alclad Light Sheen (ALC-311) mixed with Flat (ALC-314) (75%-25%) was applied over the both guns and the engine radiator/cowl.
42. Apply a weathering wash of 'Flory Models' Grime clay wash over the engine radiator/cowl (refer to Part 3 Weathering for more information).
43. Add metal chipping around the engine cowl, using either silver paint lightly 'sponged' or a dedicated silver pencil, such as 'Prismacolor' Verithin - Metallic Silver 753)
44. The windscreen frame was brush painted with Tamiya NATO Brown (XF68) lightened with White (X2) and when dry was secured in position using PVA adhesive.

Engine bay detailing:

45. Gun stays (cooling jackets): The rear of each gun cooling jacket was attached to the airframe by a 'stay' rod.

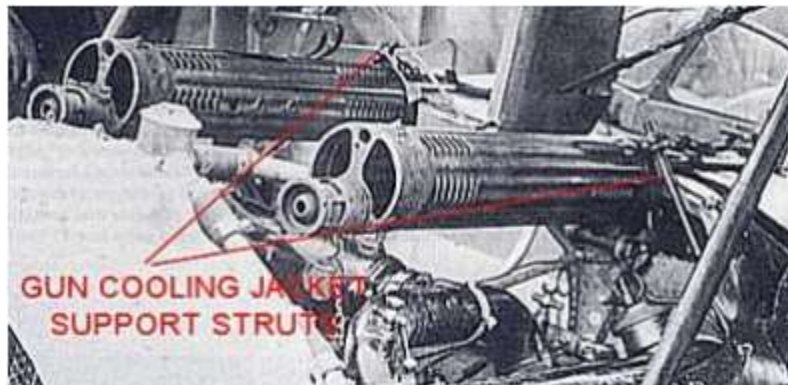

To represent these rods, insert a short length of 0.2 mm diameter Nickel-Silver rod (Albion Alloys - NST02) into a 'collar' (very short length) of 0.4 mm diameter Nickel-Silver tube (NST04), leaving it protruding. Onto the protruding tube, secure an 'RB Motion' Aluminium nut, using thin CA adhesive. Trim the 0.2 mm protruding tube to near the nut. Secure the rods in position with the nut end on the rear of the gun cooling jacket and the other end against the inside of the fuselage.

46. Engine throttle control: A hole of 0.5 mm diameter was drilled through the lower bulkhead and opposite the carburettor at the lower rear of the fuel manifold on the engine. A length of 0.3 mm diameter Nickel-Silver tube (NST03) was secured in the hole and onto the carburettor using thin CA adhesive.

47. Water temperature gauge pipe: A length of 0.3 mm diameter lead wire (Plus Models) was attached to the radiator pipe assembly, the top of the fuel manifold and the right rear fuel supply pipe using thin CA adhesive.

48. Rear gun sight: Given this aircraft was fitted with a ring site on a cross bar between the gun muzzles, I assumed a 'bead' site was also fitted in front of the pilot's windscreen. A short length of 0.4 mm diameter Nickel-Silver tube (Albion Alloys - NST04) was cut and into this was a short length of 0.2 mm diameter tube (NST02) with thin CA adhesive. The 0.4 mm end was then inserted into the hole forward from the windscreen (for the kit 'Aldis' gun sight - not used) and secured with thin CA adhesive.

49. Panel fasteners: The top forward engine access panel was secured to the fuselage sides with twist lock fasteners. These were represented by applying eight 'dots' along the fuselage edges, using an 'Airline' Drawing System ink pen (0.1 mm).

NOTE: The remaining details (Top wing to engine fuel and coolant pipes and cabane to bulkhead cross bracing) can not be installed until the top wing is fitted later in this build

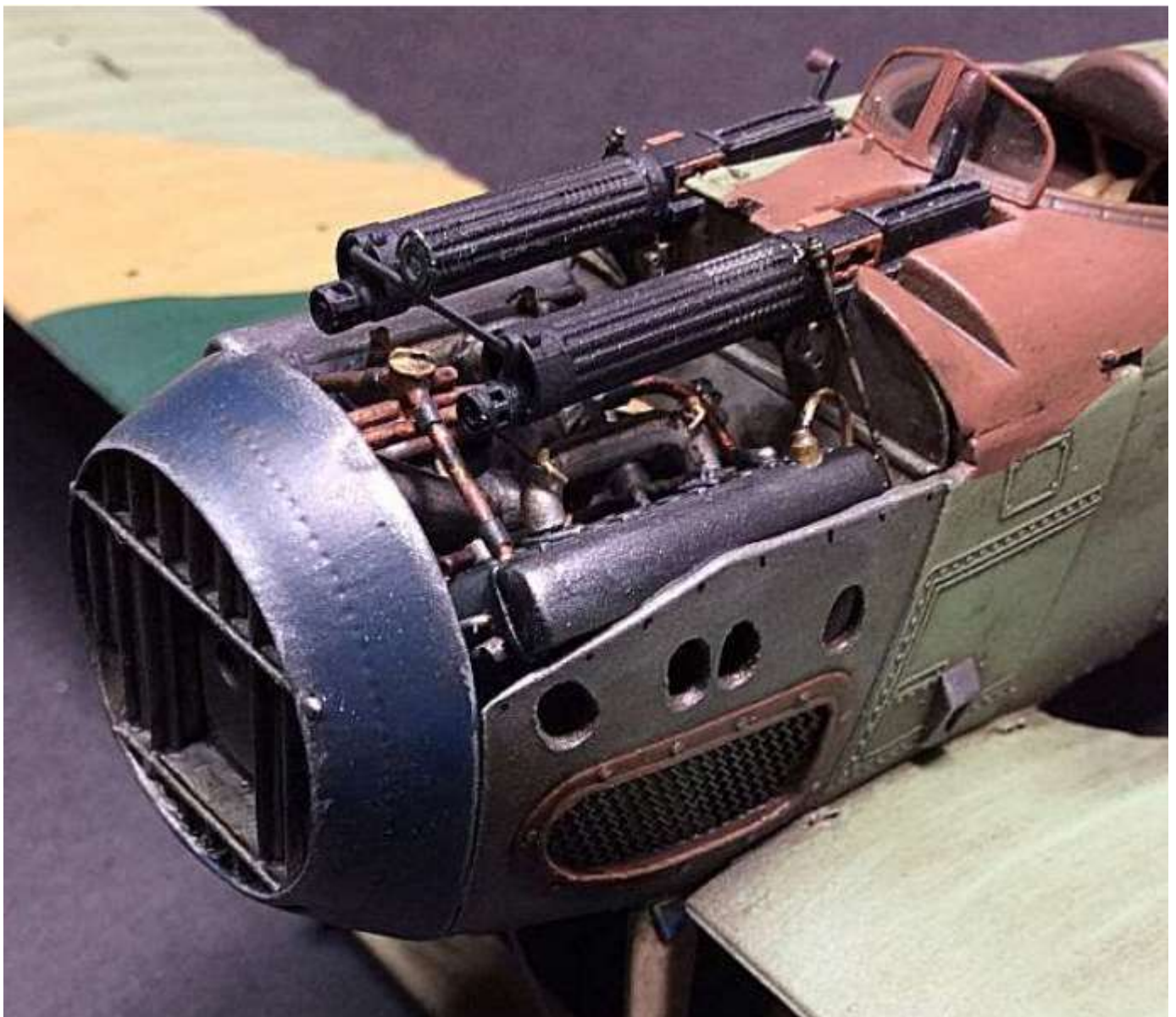



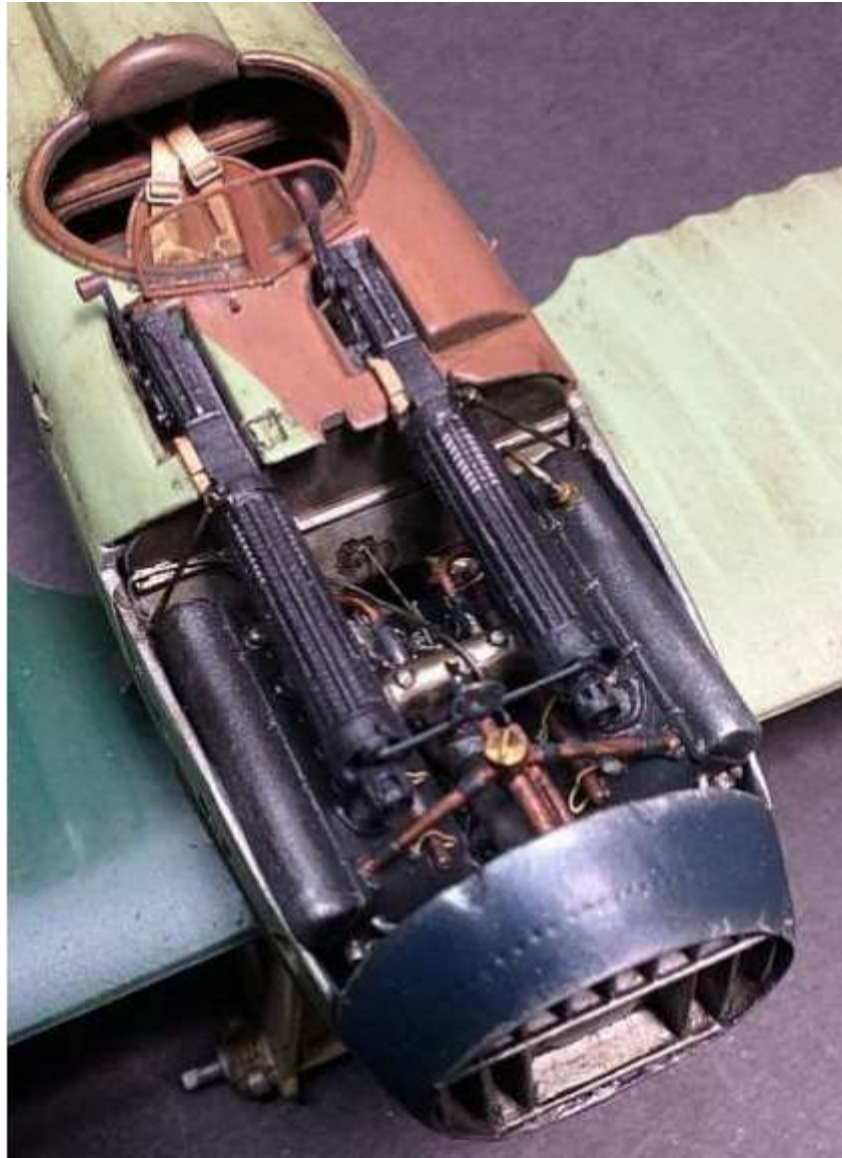

Wing and Cabane struts:

50. All wing and cabane struts were primed with airbrushed 'AK Interactive' Primer and micro-filler (White - AK759) and when dry, with Tamiya Deck Tan (XF55).
51. Once dry apply 'DecoArt Crafters Acrylic' Burnt Umber (water based oil paint) on the wing and cabane struts to create the wood effect. Refer to Part 2 - Wood Effects, for more detailed information).
52. Once dry apply a wash of 'AK Interactive' Light Wood filter (AL-261).
53. Once fully dry, seal the oil painted surfaces with an airbrushed coat of Alclad Light Sheen (ALC-311).
54. Once dry, create four equally spaced 'bands' around the vertical wing support struts (8 in total) and three bands along the two forward cabane struts only. Paint these bands with Tamiya White (XF2) mixed with a small amount of Buff (XF57) to 'knock back' the white colour.
55. Apply a weathering wash of 'Flory Models' Grime clay wash (refer to Part 3 Weathering for more information).

Aileron control and Strut fittings:

56. The aileron operating bell crank items (support brackets, bell cranks and rigging end fittings) that were created in Part 1 of this build log, were primed with airbrushed 'AK Interactive' Primer and micro-filler (Grey - AK758) and once dry airbrushed with Tamiya Rubber Black (XF85).

57. The wing and cabane strut fittings were brush painted with Tamiya Flat Blue (XF8) mixed with Rubber Black (XF85) to darken it slightly.

58. The aileron operating rods on the wing rear outboard struts were brush painted with Tamiya Dark Yellow (XF60).



Engine exhaust pipes:

59. The two exhaust support brackets, modified in Part 1 of this build log, were located into the pre-drilled holes in the fuselage sides and secured with thin CA adhesive.

60. The brackets were then primed with 'AK Interactive' Primer and Micro-Filler (AK758) and once dry, brush painted with Tamiya Rubber Black (XF85).

61. A thin strip of masking tape was wrapped twice around the exhaust pipes and over the pre-drilled holes for the support brackets. The tape covering the holes was cut away, then that area was primed with 'AK Interactive' Primer and Micro-Filler (AK758).

- 62.** Both exhaust pipes were then airbrushed with Tamiya Gun Metal (X10) thinned with Tamiya X20A thinners.
- 63.** Both exhaust pipes were coated with 'Flory Models' Weathering Wash (Brown) and when dry, lightly finger rubbed to 'just start' to reveal the gun metal finish.
- 64.** Once fully dry, seal the exhaust pipes with an airbrushed coat of Alclad Light Sheen (ALC-311).
- 65.** Final weathering was applied using 'Tamiya' Weathering Master Set B (Soot), Set C (Orange Rust) and Set D (Burnt Blue).



NOTE: The front and rear exhaust stub pipes are angled so that when the exhaust pipe is fitted, the stub pipes are angled down and the support bracket aligns correctly. Ensure the correct exhaust pipe is fitted to the correct side of the model.

- 66.** On each exhaust pipe, apply 'Fleky 5K' CA adhesive to the front and rear exhaust stub pipes and into the pre-drilled hole for locating the support bracket.
- 67.** Position each exhaust pipe into its engine access holes and onto the support bracket and hold until the CA adhesive grips.

Pilot's foot step:

- 68.** The pilot's foot step (kit item C8) was primed with 'AK Interactive' Primer and Micro-Filler (AK758)) and once dry, brush painted with Tamiya Rubber Black (XF85), then cemented into its location at the lower left side of the fuselage.

Fuselage lifting straps:

- 69.** A lifting strap, created in Part 1 of this build log, was attached with PVA adhesive, centrally onto both fuselage sides and in line with the forward edge of the fin.



Wheels:

70. Cement the two wheels onto the axle ends.

Breather cap:

71. Secure the stem of the breather cap, with thin CA adhesive, into the bore of the micro-tube pipe made in Part 1 of this build log and previously installed in the cockpit.



Pre-rigging: (Refer to Part 10 of this build log for information on rigging this model).

72. Before attempting to rig the model it's best to carefully run a 0.2 or 0.3 mm diameter drills as applicable, through the holes in the rigging attachments (photo-etch and micro-tubes). This will clear any paint or sealer and allow threading of the rigging lines.

Fitting of the wing support struts:

73. It's best at this stage to test (dry fit) the upper wing so that any adjustments can be made to the wing support struts to enable the wing to sit correctly. Also it allows for checking alignment of the rigging turnbuckles and 'eyelet' anchors. As the wing is only 'dry' fitted, it will be loose so care will be needed, otherwise dropping or damage to the struts may occur. Temporarily hold the wing in position by wrapping an elastic band over the two wings at the 'H' strut locations.

74. Once you are happy with the test 'dry' fit, remove the upper wing and support struts.

75. Ensure you have the correct 'H' support strut for each side of the lower wing and that the centre cross bar rigging attachments are orientated correctly for the flying and landing wires.

NOTE: A way to apply CA adhesive accurately is to cut away half of the end of the loop of a sewing needle to leave an open 'U'. Hold the needle in a pin vice and dip the 'U' into the CA adhesive and touch it against the joint. The adhesive will flow from the needle under capillary action.

76. Secure each 'H' support strut into its pre-drilled holes in the lower wing, using CA adhesive. I used the thicker 'Fleky 5' adhesive to locate the struts, as this gives you time to align the struts. Carefully locate the upper wing onto the struts to check for correct positioning of the two wings to each other, from the front, side and top viewpoints.

77. Give the CA adhesive a few minutes to set then remove the upper wing and re-inforce the joints using thin CA adhesive.

78. Once the joints have set, relocate the upper wing and hold in position by wrapping an elastic bane over the two wings at the 'H' strut locations.

79. Carefully check and fit the outer struts, ensuring the aileron control rod on the rear struts have the turnbuckle at the lower wing. Also ensure the strut cross bracing attachments face towards each other. **NOTE:** The kit instructions state there may be slight warpage outboard on the lower wing, so the outer struts may need to be trimmed in height to ensure the two wings are straight and parallel to each other.

80. Secure the bottom strut joints using thin CA adhesive and leave to allow the adhesive to fully set.

Pre-rigging the wing:

Before continuing it is necessary to pre-rig the fuselage and wings, as access will be restricted once the upper wing is finally fitted.

81. A short length of 0.5 mm diameter Nickel-Silver micro-tube (Albion Alloys' NST05) is cut and slid onto an appropriate length of 'Steelon' 0.12 mm diameter mono-filament line, which is passed through the eye of the turnbuckle. The line is then looped back and through the tube. The line should not be tightened against the turnbuckle at this stage.

Underside of upper wing:

82. The pre-rigged lines should be added only to the following turnbuckles:

- Outboard wing support struts x2 – cross bracing
- Inboard wing support 'H' struts x2 – cross bracing
- Centre section x2 - Landing wires
- Centre section x2 - Forward cabane struts to engine bay bulkhead.

Upper side of lower wing:

83. The pre-rigged lines should be added only to the turnbuckles and anchors of the:

- Inboard wing support 'H' struts x2 – bottom half – cross bracing.

For each of the twin flying wires, a length of line was inserted into the 0.2 mm diameter hole in each of the micro-tube 'U' shape brackets, attached at each end on the cross bar on the wing support 'H' struts. These lines were secured with thin CA adhesive.



Cabane struts – rigging anchors:

The cabane struts will be fitted after the upper, but as access to them will be very restricted, they need to be pre-rigged before fitting.

84. Clean any paint from the cabane struts and fuselage/upper wing locations, to ensure they will cement fully when fitted.

85. Add a rigging line to the two 'eyelets' fitted on the fuselage decking panel, forward from the rear cabane strut locations. Slide the micro-tube close to the 'eyelets' and secure on the line using thin CA adhesive. Trim away the exposed tag of the line.



Fitting the upper wing:

With the underside of the upper wing and fuselage pre-rigged, the upper wing can now be fitted to the wing support struts on the lower wing.

86. Carefully locate the upper wing onto the wing outboard 'H' support struts, making sure all of the pre-rigged lines are kept clear of the strut location in the upper wing. It may help to have the upper wing laying on your work surface and positioning the struts by holding the fuselage/lower wing assembly upside down.

87. Apply either thin CA adhesive or cement to the strut locations, making sure the assembly is adequately supported whilst the adhesive sets.

Fitting of the cabane support struts:

Kit items B5 are the two cabane struts for the right side and items B4 the left

Now that the upper wing has been installed, the cabane struts can be test fitted and adjusted if required before being finally fitted.

88. Cut away half of the fuselage location 'tag' at the bottom of both rear cabane struts (B5 and B4), as they may protrude into the cockpit area.

89. Cut away the fuselage location 'tag' at the bottom of both forward cabane struts (B5 and B4), as these are not required. The struts will be cemented directly onto the edges of the forward fuselage, at the rear of the engine bay.

90. Test fit the forward and rear cabane struts (B5 and B4) to the fuselage and upper wing locations to check for correct alignment and fit.

NOTE: I found them to be too long, requiring the top of the struts to be cut away until the struts located correctly into the fuselage and upper wing locations.

NOTE: Before doing the next step, take note of where the top holes in the struts need to be drilled once the cabane struts are in position. Doing this will prevent the holes being drilled too close to the end of the struts and ending up below the surface of the wing and inaccessible for rigging.

91. Rigging - Drill holes of 0.3 mm diameter through the struts at the following locations:

Forward struts B5 and B4 – trailing edges – top and bottom
Rear struts B5 and B4 – leading edges – top

92. Add a rigging line as before to the pre-drilled hole in the bottom of each of the forward cabane struts (B5 and B4). Slide the micro-tube close to the strut and secure on the line using thin CA adhesive. Trim away the exposed tag of the line.



93. Locate the rear struts (B5 and B4) into the location slots in the fuselage and upper wing and cement in position. Ensure that any rigging lines are kept clear of the cemented joints.

94. Locate the forward struts (B5 and B4) into the location slots in the upper wing and onto the fuselage sides adjacent to the engine bulkhead and cement in position. Ensure that any rigging lines are kept clear of the cemented joints.

Cabane struts - rigging:

The upper wing and four cabane struts have now been fitted.

95. In turn, for each of the four rigging lines, slide on a short length of 0.5 mm diameter Nickel-Silver micro-tube (Albion Alloy's NST05).

96. Pass the free end of the line diagonally across and through the pre-drilled hole in the opposite cabane strut.

97. Pass the free end of the line back through the micro-tube and slide the tube up to the strut.

98. Carefully tighten the line and secure tube in position using thin CA adhesive.

99. Trim away the exposed end of the line at the micro-tube.

Cross bracing -cabane strut to engine bay:

Cross bracing wires were fitted between the top of the forward cabane struts and the bulkhead at the rear of the engine bay. The bracing wires have been pre-installed to the turnbuckles on the underside of the upper wing.

100. Pass the left side line through the aperture previously drilled through the centre section pipe fairing.

101. Gently pull the free end of the line across to the right machine gun mounting bracket.

102. Pass the line through a lightening hole in the gun support bracket.

103. Pull the line tight and secure it on the support bracket using thin CA adhesive.

104. Repeat for the other line from the right cabane to the left gun support bracket.

Rigging completion:

The method for attaching the remaining rigging is the same as previously described for each location, which is micro tube onto line, line through turnbuckle, loop back through micro-tube, tighten and move tube to turnbuckle, secure with thin CA adhesive, trim off excess line.

105. The suggested sequence for completing the rigging:

Cross bracing between the cabane struts.

Wing support 'H' strut cross bracing.

Wing outer support strut cross bracing.

Single landing wires (front) – from top front cabane struts - pass through pre-drilled holes in 'H' struts to bottom outer wing struts. Slide on 0.4 mm diameter micro-tube (Albion Alloys NST04) onto line each side of the 'H' strut.

NOTE: For the rear landing wires refer to Aileron control next.

Twin flying wires (front and rear pairs) – from 'H' struts attachment tubes to wing root.

Twin flying wires (front and rear pairs) – from 'H' struts attachment tubes to top of outer wing struts.

Single rudder control lines – from rudder 'horns into fuselage slots at fin base.

Fin bracing – from hole at fin base, through fin edge to hole on other side.

Aileron control:

In part 1 of this build log the aileron bell cranks, support brackets and landing wire turnbuckle and strap were created. These parts need to be fitted now as they attach to the rear landing wires.

106. Attach the rigging line as normal to the turnbuckles at the top of the rear cabane struts.

107. From cabane strut turnbuckle, pass the line through pre-drilled holes in 'H' struts to bottom outer wing struts. NOTE: Slide on 0.4 mm diameter micro-tube (Albion Alloys NST04) onto line each side of the 'H' strut.

108. Slide onto the line a short length of 0.5 mm diameter micro-tube (Albion Alloys NST05).

109. Loop the line through the eye end of the turnbuckle/strap then back through the 0.5mm tube.

110. Secure the support bracket in position on the lower wing (ensure it's in the correct position or the rigging line won't align correctly). Secure with thin CA adhesive.

111. Locate the turnbuckle/strap through the top hole in the support bracket and locate the end opposite to the eye end against the bottom of the rear wing strut. Secure against the strut and support bracket with thin CA adhesive.

112. Carefully tighten the line, move 0.5 mm tube to turnbuckle and secure with thin CA adhesive.

113. Trim off excess line.

Painting of rigging fittings:

114. Some references show the various rigging fittings and attachments as being painted with the same blue colour used for the National markings, but others show these as being black. I chose to go with the French blue colour, which was a mix of Tamiya Flat Blue (XF8) and White (X2).

Wing fairing pipes:

115. The fairing between the underside of the upper wing and the top of the engine bay carried fuel and coolant supply pipes, which connected to the fuel carburettor and manifold. To represent these pipes, lead wire from 'Plus Models' was used.

The coolant supply pipe was created using 0.7 mm diameter 'Plus Models' lead wire, secured in position using 'Fleky 5' CA adhesive under the rear of the wing fairing and onto the top pipe at the radiator filler assembly. The rubber coupling was brush painted with Tamiya Rubber Black (XF85). The fuel supply pipe was created similarly, but using 0.5 mm diameter lead wire, securing it to the front underside of the wing fairing and the carburettor on the fuel manifold,

Forward cabane struts:

116. The two forward cabane struts can now be fitted as all of the detail in that area has been completed. The top of the struts are positioned into their location holes in the underside of the upper wing and the bottoms onto the side of the fuselage, where it angles down. These are cemented in position.

Sealing the rigging:

117. To reduce the shine on the rigging, airbrush a light coat of Alclad Light Sheen (ALC-311)

NOTE: *Remember to protect the windscreen from overspray.*

PART 12 – FIGURES and ACCESSORIES

The figures used for this model were:

'Aviattic' - Lt. Frank Luke Jnr (ATTRES 022)

'Copper State' - RFC Mechanic (32-025)

'Wings Cockpit Figures' - Seated mechanic (RFC05C).

Lt. Frank Luke Jnr:

This figure is from the Legend series produced by 'Aviattic' and is of the usual high standard, comprising the body, head and hand/flying helmet. However there appears to be two anomaly's with the figure. The left leg of the figure seemed to be posed at a strange and unnatural angle. I decided to cut the leg off at the knee and then drill a 0.8 mm hole into the both parts of the leg. A length of steel paper clip was inserted into the holes to position the leg, which was then secured in a more natural position using thin CA adhesive. Once set any gaps were filled with Masilla Plastica (401) putty.

Modified figure



The hands of the figure are molded as one piece and holding a flying helmet and goggles behind the body. The right hand is grasping the left hand, with the straps of the helmet and goggles around the two wrists. However the right hand appears to be twisted round by 180 degrees, with the thumb at the bottom and knuckles showing. A normal position for the hand would be with the palm showing.

Hands anomaly



'Hornet Models' hands



I chose not to use the 'Aviatic' hands and instead replaced them with appropriate hands from 'Hornet Models' (available from 'Historex Agents', Dover, UK) (Sets HANDS 01, 02 or 03).

Once assembled the figure was airbrushed with 'AK Extreme Primer and micro-filler Grey (AK 758). A length of steel paper clip was secured into a 1.0 mm diameter hole drilled into the right leg (for mounting to the display base). The figure was then brush painted as follows:

NOTE: When brush painting with Tamiya acrylics, I always add a small amount of Tamiya X20A thinners, in order to keep the paint fluid. Otherwise I find it doesn't brush well onto the primed surface. A good alternative thinners is Mr. Colour Levelling Thinner.

NOTE: Shadows were brushed on while the base coat was still wet, which allows you to blend the paint, rather than ending up with stark contrasts.

1. Shoes: - Mix of Tamiya NATO Brown (XF68) and Dark Yellow (XF60).
2. Leather Puttees: - Mix of Tamiya Hull Red (XF9) and Dark Yellow (XF60).
3. Trousers/Jacket: - The trousers and jacket were brush painted with a mix of Tamiya Olive Drab (XF62) and Red Brown (XF64). Shadows were added using the same mixed paint but adding a small amount of Tamiya NATO BLACK (XF69).
4. Cross belt: - Mix of Tamiya Hull Red (XF9) and Dark Yellow (XF60).
5. Insignia: -
6. Flesh: - Brush painted using 'AK Interactive' figure paints (AK3011 to 3016)
7. Hair: - Tamiya Dark Yellow (XF60) and filter wash: - 'AK Interactive' wood enamel wash (AK263) thinned with White Spirit (60% to 40% thinner).
8. An airbrushed coat of Alclad Flat (ALC-314) lacquer was applied to seal the paints.
9. Dirt stains: - 'Tamiya Weathering Master' mud (Set A).



Standing mechanic:

This figure is from 'Copper State' and is a four part model (body, two arms and head). Assembly is straightforward with only minor gaps that required filling with Masilla Plastica (401) putty.

Once assembled the figure was airbrushed with 'AK Extreme Primer and micro-filler Grey (AK 758).

The figure was then brush painted as follows:

1. Shoes: - Mix of Tamiya NATO Brown (XF68) and Dark Yellow (XF60).
2. Overalls: - Brush painted with a mix of Tamiya Dark Yellow (XF60) and Red Brown (XF64). Shadows were added using the same mixed paint but adding a small amount of Tamiya Hull Red (XF9).
3. Flesh: - Brush painted using 'AK Interactive' figure paints (AK3011 to 3016).
4. Side cap: - Brush painted with a mix of Tamiya Olive Drab (XF62) and Red Brown (XF64).
5. An airbrushed coat of Alclad Flat (ALC-314) lacquer was applied to seal the paints.
6. Grease/oil stains: - 'AK Interactive' Kerosene Leaks (AK 2039).
7. Dirt stains: - 'Tamiya Weathering Master' mud (Set A).



Seated mechanic:

This figure is from 'Wings Cockpit Figures' and is a three part model (body and two arms. This set also includes other items, such as a haversack and box crate, which I used for this model. Assembly of the figure is straightforward with only minor gaps that required filling with Masilla Plastica (401) putty.

Once assembled the figure was airbrushed with 'AK Extreme Primer and micro-filler Grey (AK 758). The figure was then brush painted as follows:

1. Shoes: - Mix of Tamiya NATO Brown (XF68) and Dark Yellow (XF60).
2. Puttees: - Brush painted with Tamiya Dark Yellow (XF60) washed with 'AK Interactive' wood enamel wash (AK263) thinned with White Spirit (60% to 40% thinner).
3. Flesh: - Brush painted using 'AK Interactive' figure paints (AK3011 to 3016).
4. Side cap: - Brush painted with a mix of Tamiya Olive Drab (XF62) and Red Brown (XF64).
5. Trousers: - Brush painted with a mix of Tamiya Dark Yellow (XF60) and Red Brown (XF64). Shadows were added using the same mixed paint but adding a small amount of Tamiya NATO BLACK (XF69).
6. Coat: - Same mix of paint for the trousers but adding Tamiya Hull Red (XF9).
7. An airbrushed coat of Alclad Flat (ALC-314) lacquer was applied to seal the paints.
8. Grease/oil stains: - 'AK Interactive' Kerosene Leaks (AK 2039).
9. Dirt stains: - 'Tamiya Weathering Master' mud (Set A).



Box crate:

The crate was primed with 'AK Extreme Primer and micro-filler Grey (AK 758), then brush painted as follows:

1. Base coat: - 'AK Interactive' British Uniform (AK3081).
2. Chipped edges/rope handles: - Tamiya Dark Yellow (XF60).
3. Filter wash: - 'AK Interactive' wood enamel wash (AK263) thinned with White Spirit (60% to 40% thinner).
4. Airbrushed coat of Alclad Flat (ALC-314) lacquer was applied to seal the paints



Haversack:

The haversack was primed with 'AK Extreme Primer and micro-filler Grey (AK 758), then brush painted as follows:

1. Base coat: - Tamiya Dark Yellow (XF60) with drop of NATO Brown (XF68).
2. Filter wash: - 'AK Interactive' wood enamel wash (AK263) thinned with White Spirit (60% to 40% thinner).



Hand tools:

Selected photo-etched hand tools from the 'Aber' set and a tool boxes (from my spares) were primed with 'AK Extreme Primer and micro-filler Grey (AK 758), and when dry, brush painted with Mr. Colour Master Stainless Steel (213). When dry these were given a wash of Flory Models' Weathering Wash (Dart Dirt), then lightly buffed using a cotton bud.

Oil/fuel drum:

The oil/fuel drum (from my 'spares' box) was first primed with 'AK Interactive' Primer and Micro-filler (AK 758), and when dry airbrushed with Alclad Alumium (ALC-101) lacquer. Once dry, two coats of 'AK Interactive' Worn Effects (AK 088) was applied. As soon as the second coat was dry, the drum was airbrushed with thinned Tamiya Dark Green (XF70) mixed with Black (X1), to darken the green colour.

The surface was wetted with water (to react with the underlying Worn Effects surface), then with a wood tooth pick and/or small stiff brush, was gently 'picked at' to lift small areas of the green topcoat to recreate paint chips and scratches etc.

Once the desired effect was achieved, the drum was airbrushed with Alclad Light Sheen (ALC-311) mixed with Flat (ALC-314).

Final weathering was applied using 'AK Interactive' Kerosene (AK 2039) and Engine Wash (AK – 2033) then Tamiya Weathering Master (Set C – Silver).



Fuel container:

The fuel container (from my 'spares' box) was first primed with 'AK Interactive' Primer and Micro-filler (AK 758), and when dry airbrushed with Alclad Alumium (ALC-101) lacquer. Once dry, two coats of 'AK Interactive' Worn Effects (AK 088) was applied. As soon as the second coat was dry, the barrel was airbrushed with thinned Tamiya Red (X7) mixed with Black (X1), to darken the green colour.

The surface was wetted with water (to react with the underlying Worn Effects surface), then with a wood tooth pick and/or small stiff brush, was gently 'picked at' to lift small areas of the green topcoat to recreate paint chips and scratches etc.

Once the desired effect was achieved, the container was airbrushed with Alclad Light Sheen (ALC-311) mixed with Flat (ALC-314) and final weathering was applied using 'AK Interactive' Kerosene (AK 2039) and Engine Wash (AK – 2033) then Tamiya Weathering Master (Set C – Silver).



Tail trestle:

To support the tail of the fuselage and to level the aircraft, as though under going maintenance, I used the tail trestle from the 'Kellerkind' accessories set (No.56/061). This set contains ladders, trestle, small table etc, which are made of thin, laser cut wood and need to be assembled, using CA or PVA adhesive.

Once assembled, the trestle was primed with airbrushed 'AK Interactive' Primer and Micro-filler (AK 758).

The trestle was then brush painted as follows:

1. Base coat: - 'Tamiya' NATO Brown (XF68) mixed with Flat Earth (XF52).
2. Filter wash of 'AL Interactive' Brown Wood (AK-262).
3. Airbrushed coat of Alclad Flat (ALC-314) lacquer was applied to seal the paints.
4. Weathering - Apply wash of with 'Flory Models' Weathering Wash (Dart Dirt).
5. Edge stain and chipping – Tamiys Weathering Master Set A (Sand) and Set B (Soot).



PART 13 - DISPLAY BASE

The display case is made from 6mm thick Piano Black Acrylic sheet and the transparent top is fabricated from 3mm thick Clear Acrylic sheet. This was made for me by an on-line manufacturer.

The name plaque was also made by an on-line retailer and was attached to an angled mount, which was secured to the display base with a contact adhesive..

The aircraft model, figures and accessories were located on the base in their final positions. The the grass mat ('Polak' Wild Meadow (variation F - 4706) was then cut to shape. The model parts were removed and the mat repositioned on the base with its outline traced using a hard leaded pencil. The mat was removed and the area outlined carefully scuffed using a fine grit sand paper. The clear plastic backing was removed from the grass mat and PVA adhesives applied to the backing (not too much or the adhesive will squeeze out from the edges). The mat was then repositioned on the display base and a layer of 'kitchen wrap (e.g.'Clingfilm') was laid over the mat and heavy weights, such as books, were laid onto the film. This ensured the grass mat adhered fully to the display base. After several hours the books and film were removed. The angled support for the model information plaque was attached to the front, left corner of the base using two part epoxy adhesive ('Araldite').



The model and accessories were repositioned on the grass mat and their locations noted. The locations of the two aircraft wheels, four trestle legs, barrel, liquid container, haversack, tool box and the box crate were cut out from the grass mat. The trestle then aircraft were secured in position using PVA adhesive. Then each of the other items were secured in position using CA adhesive ('Fleky 5'). The standing mechanic figure was then secured in position on the box crate and the other mechanic (seated) onto the barrel, using CA adhesive. Finally the steel locating pin in the leg of the Frank Luke figure was inserted into a 1.0 mm diameter hole, drilled through the grass mat and into to base. The figure was secured in position using CA adhesive.

COMPLETED MODEL PHOTOGRAPHS



