



World War One Aircraft Models

I have always held a fascination with early military aircraft. After serving for 27 years in the Royal Air Force, I became a Military Aerospace Technical Author. Although, as most modelers, I got involved in the world of construction kits at an early age, I stopped for most of my service career and for some years afterwards.

I started modeling again a few years ago and now enjoy the challenge of building aircraft of World War One. Since posting photographs of my completed models online, several people have asked if I would create a 'build log' for future builds.

I don't consider myself a 'master' of this craft, but hope to be able to pass on what I have learned. As such, here is my build log, which covers the 1:32 scale resin model of the Hanriot HD-1 by 'Lukgraph'.

Mike 'Sandbagger' Norris

sandbaggeruk@sky.com

<https://mikesww1aircraftmodels.com>

Completed: November 2023

CONTENTS

INTRODUCTION

AFTER MARKET

THE AIRCRAFT

THE PILOT

PART 1 - MODEL DESCRIPTION

PART 2 - WOOD EFFECTS (General)

PART 3 - WEATHERING (General)

PART 4 - DECALS (General)

PART 5 - RESIN (General)

PART 6 - RIGGING (General)

PART 7 - ENGINE

PART 8 - WEAPON

PART 9 - PROPELLER

PART 10 - FUSELAGE

PART 11 - CONSTRUCTION

PART 12 - FIGURES

PART 13 - DISPLAY BASE

PART 14 - COMPLETED MODEL PHOTOS

INTRODUCTION

Before I start with the build log, I'd like to show how I've set up my work area. I prefer to keep the work area as clear as I can (I've lost too many small items in the past). I think it's important to have the tools etc you need ready to hand and other, non-essential stuff tucked out of the way until needed. I'm lucky in that I have my 'man cave', which is sorted into a modelling area, airbrush spray booth in addition to my work station PC, games PC and games console.



AFTER MARKET

AFTER MARKET

Figures

'Copper State Models' French mechanic (F32-046),
'Kellerkind' U.S.A.A.S pilot (54-051),

Decals

Airscale 'Generic WW1 instruments (AS32 WW1) set,

Resin

'Gaspatch Models' Vickers 'Balloon Buster' machine gun (13-32042),
'Hornet' 1:35th scale resin head.

Rigging accessories (as required)

'GasPatch Elite Accessories' Turnbuckles (1/48 scale),
'Albion Alloy's' Micro-tube (Brass or Nickel Silver - various diameters),
'Steelon' or 'Stroft GTM' Mono-Filament (0.08 and 0.12 mm diameter).

Sundries (as required)

Paints ('Tamiya' Acrylic, Humbrol Acrylic, 'Mr. Metal Colour', 'AK Interactive' Primer and micro-filler (Grey AK758, White AK759), 'Alclad II' Lacquers, 'Hataka' Orange top, 'Alclad' Aqua Gloss 600 or 'Mig' A-Stand Aqua Gloss (A.Mig-2503), 'Mr. Colour' Levelling Thinners, PVA Adhesive (e.g. 'MicroScale' Micro Krystal Clear), 'MicroScale' MicroSol/MicroSet, 'VMS Fleky' CA adhesive (Slow and Thin), 'UHU' White Tack, 'Mr. Hobby' dissolved putty, 'Mr. Surfacer' 500, or 1000, 'PlusModel' lead wire, 'Tamiya' extra thin liquid cement, 'Plastic Magic' liquid cement, 'White Spirits', 'Abteilung 502' and 'Windsor & Newton' Griffin Alkyd oil paint, 'MFH' 0.4mm diameter flexible black tube (P-961), 'EZ' black stretch line (Fine), White (heavy), Copper wire (various diameters), 'Araldite' 2 part epoxy resin adhesive, 'Mr. Colour' Levelling Thinners 400.

Weathering mediums (as required)

'Flory Models' Clay washes and Pigments, 'AK Interactive' (Kerosene AK-2039, Oil AK-2019),
'Tamiya' Weathering Master (Set C, D and E).

Display Base

'Polak' Wild Meadow variant E (4705) grass mat,
'Inperspective' custom made Acrylic base and cover,
Information plaque from 'TLS Engraving Ltd'.

THE AIRCRAFT

THE AIRCRAFT

References:

Windsock Date file No.12 - Hanriot HD.1 (by J.M Bruce).

Osprey Aircraft of the Aces No.66 - Balloon Busting Aces of WW1 (by Jon Guttman).

Online Wikipedia.

General:

The Hanriot HD.1 was a French World War I single-seat fighter aircraft. Rejected for service with French squadrons in favour of the SPAD S.VII, the type was supplied to the Belgian *Armée Aviation Militaire Belge* (Belgian Military Aviation) and the *Corpo Aeronautico Militare* (Military Aviation Corps) of the Royal Italian Army, with both of which it proved highly successful. Of a total of about 1,200 examples built, 831 were produced by Italian companies under licence.

The Hanriot company produced a series of pioneering monoplanes pre-war, but had settled down as a licence manufacturer, notably of Sopwith 1½ strutters, when the HD.1 was produced in 1916. The type was a conventional fighter with the general characteristics of a typical Sopwith aircraft, being strongly but lightly built and combining clean lines with a light wing loading. It used the same "1½" (or "W") cabane strut arrangement as the Sopwith two-seater. It had a flat lower wing, though the top wing had quite sharp dihedral.

Fitted with the 110 hp (82 kW) Le Rhone rotary engine, the aircraft was not outstandingly fast, but it was very manoeuvrable and proved popular with pilots as a safe and pleasant aircraft to fly. To maintain a competitive climbing and altitude performance it was usual practice to restrict armament to one synchronised Vickers machine gun, although there was provision for a second gun and one was occasionally fitted. In French-built aircraft the gun (or guns) were fitted to the sides of the cockpit and were accessible to the pilot without their butts being directly in front of his face in the event of a crash – an unusual but welcome feature, even if its origins lay in the form of the cabane struts. Italian-built versions mounted one machine gun centrally. The type was also produced by the Nieuport-Macchi company of Varese, Italy, which built almost 900 HD.1s between 1917 and 1919, which was more than the parent firm.

The new type was ordered into production as a possible replacement for the Nieuport 17, but became superfluous when it was decided to replace the Nieuport with the SPAD S.7 in the French air service. Some were supplied to the French Navy, a few of which were eventually passed to the U.S. Navy and some naval Hanriot's were converted to or built as floatplanes with enlarged tail surfaces. The bulk of early production was supplied to the Belgians, who previously had to use inferior Allied aircraft. With the Belgian fighter squadrons the HD.1 proved surprisingly successful and the type remained the standard Belgian fighter for the rest of the war. Willy Coppens, the top Belgian ace of the war, was the most successful HD.1 pilot. At least one of his machines was experimentally fitted with an 11 mm Vickers machine gun for use in balloon busting, something at which Coppens excelled. Most of his victories were balloons and many were claimed while flying the HD.1. These aircraft remained in use until the late 1920s. The type was also supplied in small numbers to the Italians, who manufactured it in quantity and used it to replace Nieuports and SPADs. The type was considered by the Italians to be a better all-round fighter than even the SPAD S.XIII and it became the standard Italian fighter, equipping 16 of the 18 operational Italian fighter squadrons by November 1918. Surplus Italian-built Hanriot's were used by several countries postwar, including the Swiss. The U.S Navy built (or possibly modified/converted) 10 HD.1s in the immediate postwar years. These were mainly used as trainers, although they were also involved in experiments with take-off platforms on warships. They could be fitted with twin guns and at least one machine had a hydrovane and flotation bags of the type developed for the Royal Navy. Five examples of the HD.1 are preserved in museums in Europe and the US:

General specifications:

Length - 19' 2" (5.85m)

Wingspan - 28' 7" (8.7m)

Height - 9' 8" (2.94m)

Empty weight - 897 lb (407kg)

Loaded weight - 1,334 lb (604kg)

Engine - Le Rhone 9J rotary 109hp (81kW)

Performance:

Maximum speed - 141 mph (184km/h)

Service ceiling - 21,000 ' (6,400m)

Rate of climb - 5min 6sec to 6,562 ' (2,000m) - 11min to 9,843' (3,000m)

Range - 340 miles (550 km)

Weapons:

1 or 2 Vickers 0.303" (7.7mm) machine guns.

Aircraft colour scheme:

The aircraft modelled is the Hanriot HD.1 of the Belgian pilot Willy Coppens of the 9th Escadrille, Belgium, 1918.

The undersides were doped with an Aluminium colour. The upper surfaces of the tailplane and elevator were painted with blue 'sun rays' on a white background.

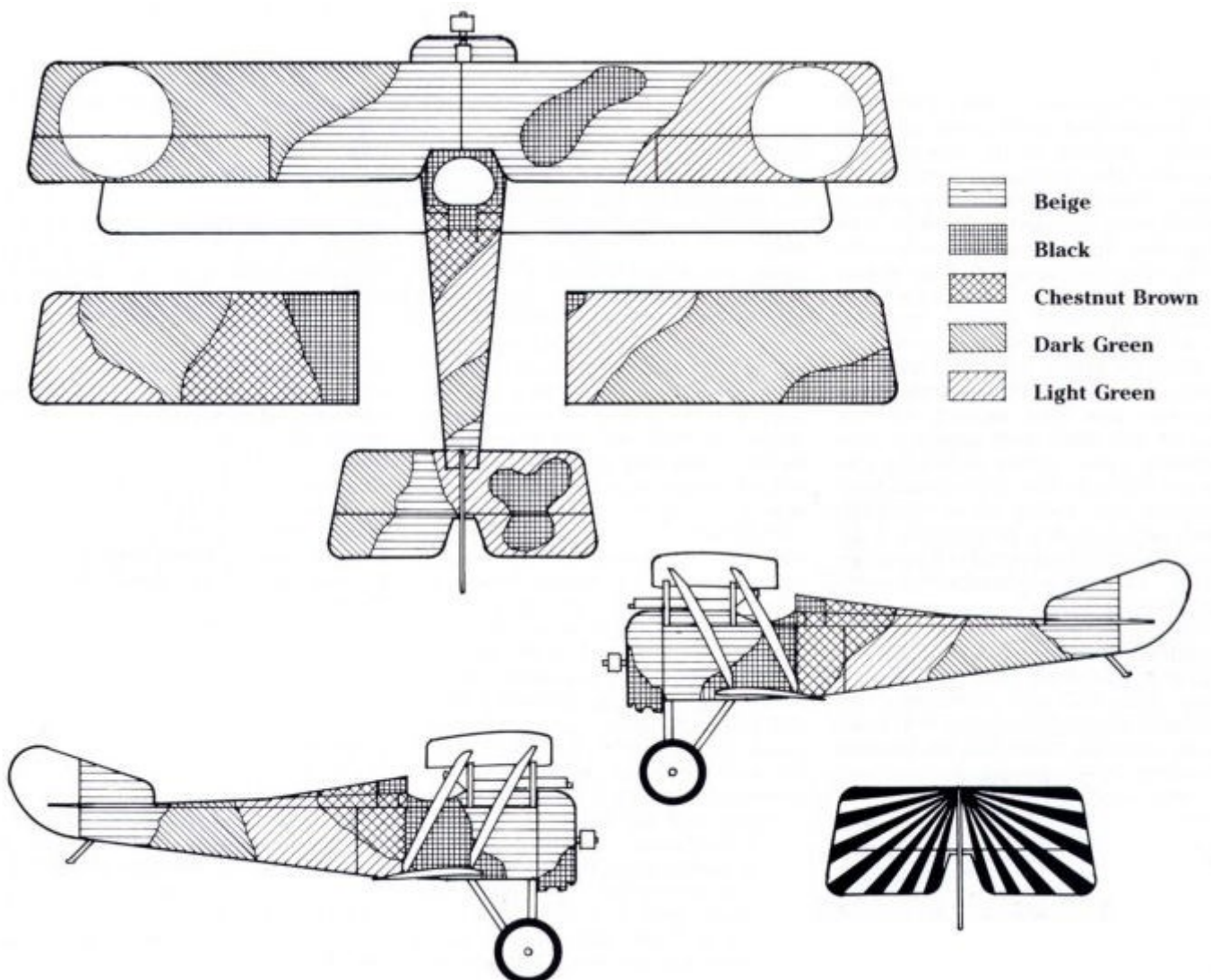



THE PILOT

THE PILOT

References:

Windsock Date file No.12 - Hanriot HD.1 (by J.M Bruce).

Osprey Aircraft of the Aces No.66 - Balloon Busting Aces of WW1 (by Jon Guttman).

Online Wikipedia.

Willy Omer François Jean baron Coppens d'Houthulst, DSO, MC was Belgium's leading fighter ace and the champion "balloon buster" of World War I. He was credited with 37 confirmed victories and six probables. He flew with Escadrille 1ère, 4me, 6me and 9me.

Coppens was born on the 6th of July 1892 in Watermael-Boitsfort, the son of Omer Coppens, a Belgian impressionistic painter who studied in the Royal Academy of Ghent. Willy Coppes was conscripted into the army in 1912, to serve with the Premiere Regiment Grenadiers. In 1914, following the German invasion of Belgium, Coppens transferred to The Motor Machine Gun Corps. On the 6th of September 1915, he signed up for flight training in the Compagnie des Aviateurs. Ultimately, due to insufficiencies in Belgian training, he took eight weeks of leave to train to fly. He and 39 other Belgians learned to fly on their own expense in Britain. He received his pilot's certificate on the 9th December 1915. After this training in Britain he had further training at the Farman School in Étampes, France and joined the Sixieme Escadrille as a sergent 1st class (Sergeant First Class) on the 8th of April 1917 flying BE-2c two seaters. Later that month, he was assigned to Quatrieme Escadrille to fly a Farman pusher. On the 1st of May, he received a Sopwith 1½ Strutter two seater and promptly flew it into his first aerial combat.

In mid July, he transferred to the single seater fighter unit 1ère Escadrille de Chasse (1st Pursuit Squadron). He received the last remaining Nieuport 16 in the squadron; everyone else had upgraded to Nieuport 17s. When Hanriot HD.1s were offered to the squadron, he was the only pilot to initially accept one. His enthusiasm for the aircraft type prompted other pilots to also move over to the Hanriot.

On 19 August Coppens was promoted to Adjutant. He continued his nervy but unsuccessful combat career against enemy aircraft until the 17th of March 1918. On that day he carried out his first attack on German observation balloons, as an aid to a ground assault by the Belgian Army. Though handicapped by lack of incendiary ammunition he punctured two balloons, causing the observers to bail out and the balloons to collapse to the ground.

Finally, on the 25th of April Coppens scored his first aircraft victory by downing a Rumpler two seater. On the 8th of May he finally found his metier, when he shot two balloons down in flames. A week later, using his usual tactics of close range fire, Coppens cut a balloon loose from its ties. It bounced up beneath him and momentarily carried his Hanriot skyward. After his aircraft fell off the balloon, he restarted its engine and flew back to base. The balloon sagged into an explosion. Later when on another attack run, he got shot at from a balloon. He parked his plane on top of the damaged balloon, shut down his engine in order to protect its propeller, and waited until the balloon descended to slide off the balloon and fly away. From then on, his record was spectacular. Between April and October 1918 he was credited with destroying 34 German observations balloons and three aircraft, nearly as many victories as Belgium's other five aces combined. Unlike most fighter pilots of World War I, who used .303 calibre or 7.92 mm guns, Coppens used a larger bore 11 mm Vickers machine gun, having upgraded his weapon prior to June 1918. In June, he was promoted to sous lieutenant, thus becoming an officer. His royal blue plane with its insignia of a thistle sprig wearing a top hat became so well known that the Germans went to special pains to try to kill him. On the 3rd of August he shot down a balloon booby-trapped with explosives that when detonated from the ground nearly killing him. The flaming wreckage of the balloon fell on the watching German staff officers, killing many and injuring the rest.

On his last mission, on the 14th of October, Coppens downed a balloon over Pratboss and was attacking one over Tohout when he was severely wounded by an incendiary bullet, smashing the tibia of his left leg and severing the artery. Coppens crash landed near Dilsmuide and was taken to hospital, where his leg was amputated.

Coppens achieved all of his victories flying the Hanriot HD.1 fighter.

For his wartime service he was knighted, becoming Willy Omer Francois Jean Coppens de Houthulst (Houthulst was a forest in his squadron's operating area). He was decorated by Belgium, France, Britain, Portugal, Italy, Poland, and Serbia. His memoir 'Days on the Wing' were published in 1931 and reissued in the 1970s as 'Flying in Flanders'.

His bestowed honours included:

Order of Leopold II

Order of the Crown

Belgian Croix de Guerre

French Legion d'Honneur

French Croix de Guerre

Serbian Order of the White Eagle

British Distinguished Service Order

British Military Cross

Willy Coppens received the exceptional honour to add 'd'Houthulst' after his noble title, referring to a wood he often overflew during the First World War.

His arms consist of 3 silver flying eagles on a blue background.

His motto was 'Je surmonterai' (I will overcome).

Willy Coppens deemed honours and awards to be very important, as he felt they ought to be a token of recognition. In his opinion, they should not be granted automatically and he felt it was unjust that lower ranking frontline servicemen received lower ranks in national orders than commanding generals that did not participate in active combat. This feeling showed when in 1959 and 1968 he refused the Commander's cross in the Order of Leopold, based on the fact that a pilot who deserted the 'Compagnie des aviateurs' on the 23rd of August 1914, after only 20 days of service received the Grand Officer's cross of the same order, a higher rank than the Commander's cross offered to him.

Between the two World Wars Coppens was Belgian air Attaché to four nations. In September 1928, despite his disability, he set a parachute jump record by leaping from 19,700 feet (6,000 meters). This record stood for four years. He retired to Switzerland in 1940, organising resistance work and marrying. In the late 1960's he lived his last five years in Berchem, Belgium with fellow Belgian ace Jan Olieslagers's only daughter until his death on the 21st of December 1986.

Victories scored during WW1

	DATE	TIME	SQUADRON	AIRCRAFT	ENEMY	LOCATION
1	25 Apr 1918	1220	Escadrille 9me	Hanriot HD.1	Scout	St. Joris
2	8 May 1918	0710	Escadrille 9me	Hanriot HD.1	Balloon	Zarren
3	8 May 1918	0955	Escadrille 9me	Hanriot HD.1	Balloon	Houthulst
4	15 May 1918	0807	Escadrille 9me	Hanriot HD.1	Balloon	Houthulst

5	19 May 1918	0945	Escadrille 9me	Hanriot HD.1	Balloon	Houthulst
6	5 June	0640	Escadrille 9me	Hanriot HD.1	Balloon	Houthulst
7	9 June	0922	Escadrille 9me	Hanriot HD.1	Balloon	Zonnebeke
8	10 June	0747	Escadrille 9me	Hanriot HD.1	Balloon	Ploegsteert
9	24 June 1918	0645	Escadrille 9me	Hanriot HD.1	Balloon	Warneton
10	24 June 1918	0646	Escadrille 9me	Hanriot HD.1	Hannover CL	Ploegsteert
11	30 June	0630	Escadrille 9me	Hanriot HD.1	Balloon	Bovekerke
12	30 June	0830	Escadrille 9me	Hanriot HD.1	Balloon	Gheluvelt
13	30 June	0834	Escadrille 9me	Hanriot HD.1	Balloon	Passchendaele
14	14	0930	Escadrille 9me	Hanriot HD.1	Balloon	Passchendaele
15	16	1855	Escadrille 9me	Hanriot HD.1	Balloon	Bovekerke
16	19	1920	Escadrille 9me	Hanriot HD.1	Balloon	Ruyterhoek
17	20	0557	Escadrille 9me	Hanriot HD.1	Balloon	Houthulst
18	22	0730	Escadrille 9me	Hanriot HD.1	Balloon	Gheluwe
19	22 Jul1918	0731	Escadrille 9me	Hanriot HD.1	Balloon	Wervicq
20	22 Jul1918	0734	Escadrille 9me	Hanriot HD.1	Balloon	Comines
21	24 Jul1918	1920	Escadrille 9me	Hanriot HD.1	Balloon	Ruyterhoek
22	3 Aug 1918	0750	Escadrille 9me	Hanriot HD.1	Balloon	Reutel
23	10 Aug 1918	0605	Escadrille 9me	Hanriot HD.1	Balloon	Leffinge
24	10 Aug 1918	0625	Escadrille 9me	Hanriot HD.1	Balloon	Ruyterhoek
25	10 Aug 1918	0745	Escadrille 9me	Hanriot HD.1	Balloon	Leffinge

26	24 Aug 1918	1455	Escadrille 9me	Hanriot HD.1	Balloon	Ploegsteert
27	24 Aug	1457	Escadrille 9me	Hanriot HD.1	Balloon	Warneton
28	3 Sep	1102	Escadrille 9me	Hanriot HD.1	Balloon	Tenbrielen
29	4 Sep	0923	Escadrille 9me	Hanriot HD.1	Balloon	Wercken
30	27 Sep	1105	Escadrille 9me	Hanriot HD.1	Balloon	Leffinge
31	27 Sep 1918	1106	Escadrille 9me	Hanriot HD.1	Balloon	Leffinge
32	29 Sep 1918	1005	Escadrille 9me	Hanriot HD.1	Two Seater	Leffinge
33	2 Oct 1918	1520	Escadrille 9me	Hanriot HD.1	Balloon	Leffinge
34	3 Oct 1918	08914	Escadrille 9me	Hanriot HD.1	Balloon	Lendeleede
35	5 Oct 1918	0820	Escadrille 9me	Hanriot HD.1	Balloon	Cruypenaerde
36	5 Oct 1918	0600	Escadrille 9me	Hanriot HD.1	Balloon	Praatbos
37	14 Oct 1918	0605	Escadrille 9me	Hanriot HD.1	Balloon	Torhout

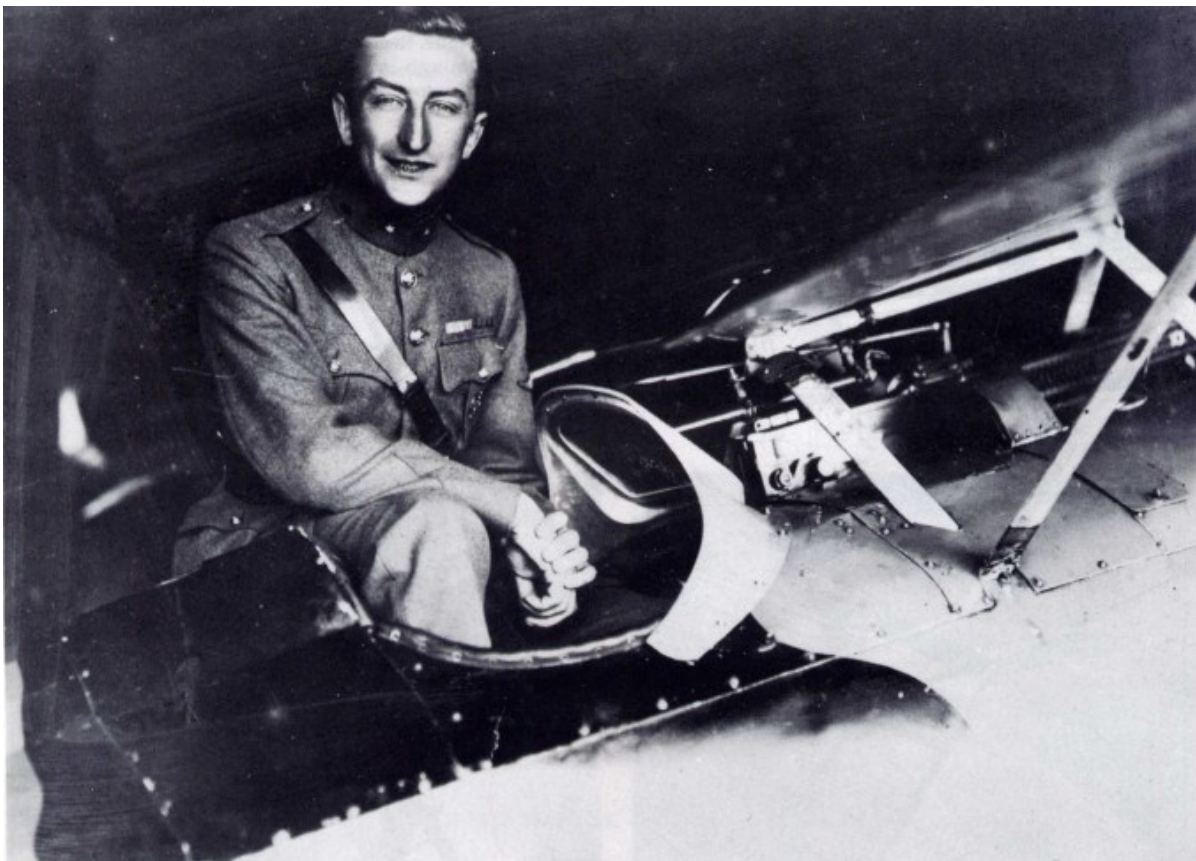

Coppens (in the centre) in 1919



Willy Coppens decorated by King Albert I.



PART 1
MODEL
DESCRIPTION

PART 1 - MODEL DESCRIPTION

(‘Lukgraph’ - Kit No:32-048)

This 1:32nd scale model is manufactured by ‘Lukgraph’ and is manufactured primarily in a grey coloured resin, which initially looks like standard styrene. Other parts, such as the engine, cockpit interior and engine cowls are 3D printed. The kit supplies the model parts, 3D printed parts, decal sheet and the instruction booklet. This particular model is of the French designed Hanriot HD.1 fighter and is also available as the HD.2 floatplane version

The kit instruction booklet has eight assembly sheets, one rigging sheets and six colour scheme illustrations. The supplied decals and colour illustrations cover Belgian, Italian and captured aircraft. Although fairly brief, the instructions seem to be concise. Also supplied is a photo-etch sheet for cockpit and acetate sheet for the windscreen.

This model is a new release and with new tool moulds there shouldn't be any obvious problems with the model parts, such as can occur with resin kits, such as mis-moulds/short shots, tooling marks, air bubble ‘blow holes, heavy resin flash are the parts or warping of parts. However, there are a few minor areas that will need to be addressed, such as casting marks on some resin parts and struts have reinforcing rods through them, which appear to be central, which is good. However, some of the strut rods are so close to the surface, they can be clearly seen through the resin skin, which may cause them to be weaker than they should be and may even suffer break through of the rods. Also the resin used for the more delicate 3D printed parts is brittle and smaller parts can easily be broken, unless due care is taken when handling those parts.

CA adhesive must be used to attach and assemble the model parts as normal styrene cement has no effect on resin.

Finally, the decals from ‘Lukgraph’ can be translucent, meaning the underneath colours on the model may shown through the decals after application. In that case a white decal or paint should be used under the decals.

Any after market additions or modifications will be covered in the relevant Part of this build log.

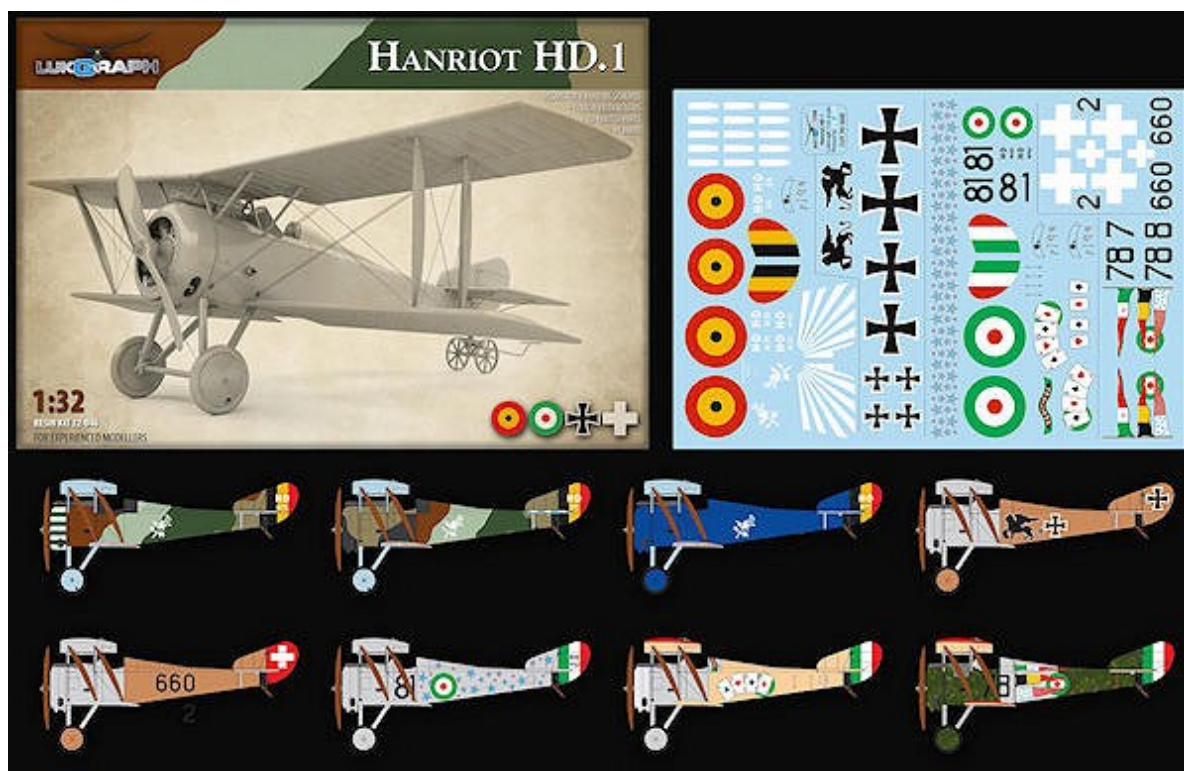

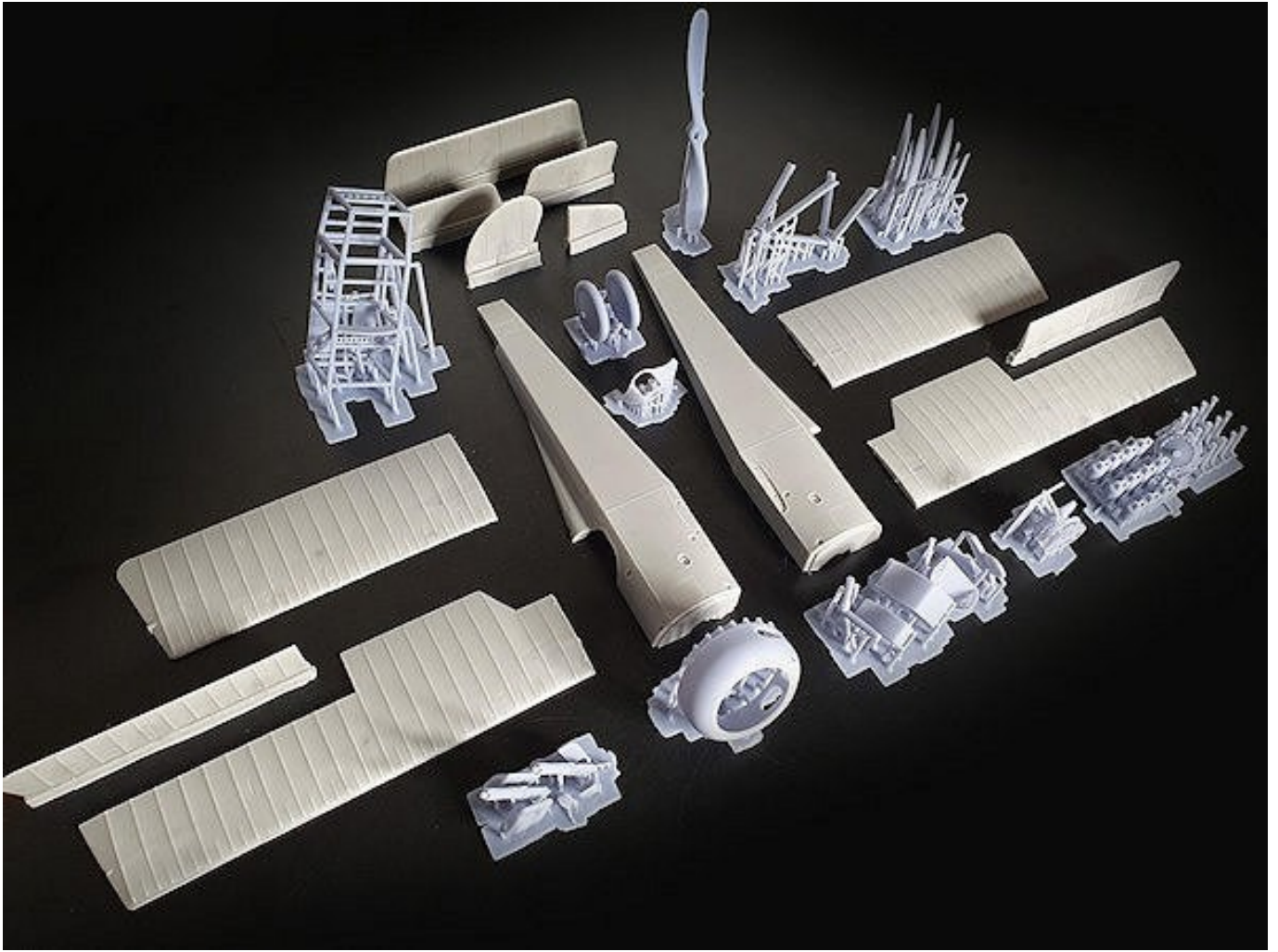

PART 2
WOOD EFFECTS
(General)

PART 2 - WOOD EFFECTS (General)

A basic technique:

Parts of the model that are supposed to be made of wood can prove to be a challenge to replicate a wood finish to the part. Some after market companies produce accurate wood decals, which can be used to cover larger areas, such as cockpit decking and fuselage panels. However, decals can't easily be used to create realistic wood finish to smaller items or parts that don't lend themselves to having decals applied. To do this requires brush painting, using such as acrylic or oil paints, which can be enhanced with various washes or filters.

The first thing to do is to ensure the model parts are cleaned, normally with warm water with washing up fluid and something like an old tooth brush. Once cleaned and thoroughly dried, the primer coat can be applied. I use 'Tamiya' Aerosol Light Grey (Fine) or White (Fine) acrylic primer. Once the primer is dry, you can start applying the wood effect to the applicable cockpit items, such the cockpit framework, decking, seat supports, rudder bar, instrument panel and of course, the wing struts. With practice, this method can also be used on fuselage panels and propellers.

To start, apply a suitable base colour. For most painting I use an airbrush and only resort to brush painting when dealing with small items, when I add a few drops of 'Mr. Colour' Levelling Thinner', which aids brush painting. For most wood effect, I use 'Tamiya' Wooden Deck Tan (XF78) or Dark Yellow (XF60), suitably thinned with 'Tamiya' Thinners (X20A). Allow this base coat to fully dry (if you can't smell the paint, then it's dry).

Example of base coat using 'Tamiya' Wooden Deck Tan (XF78).

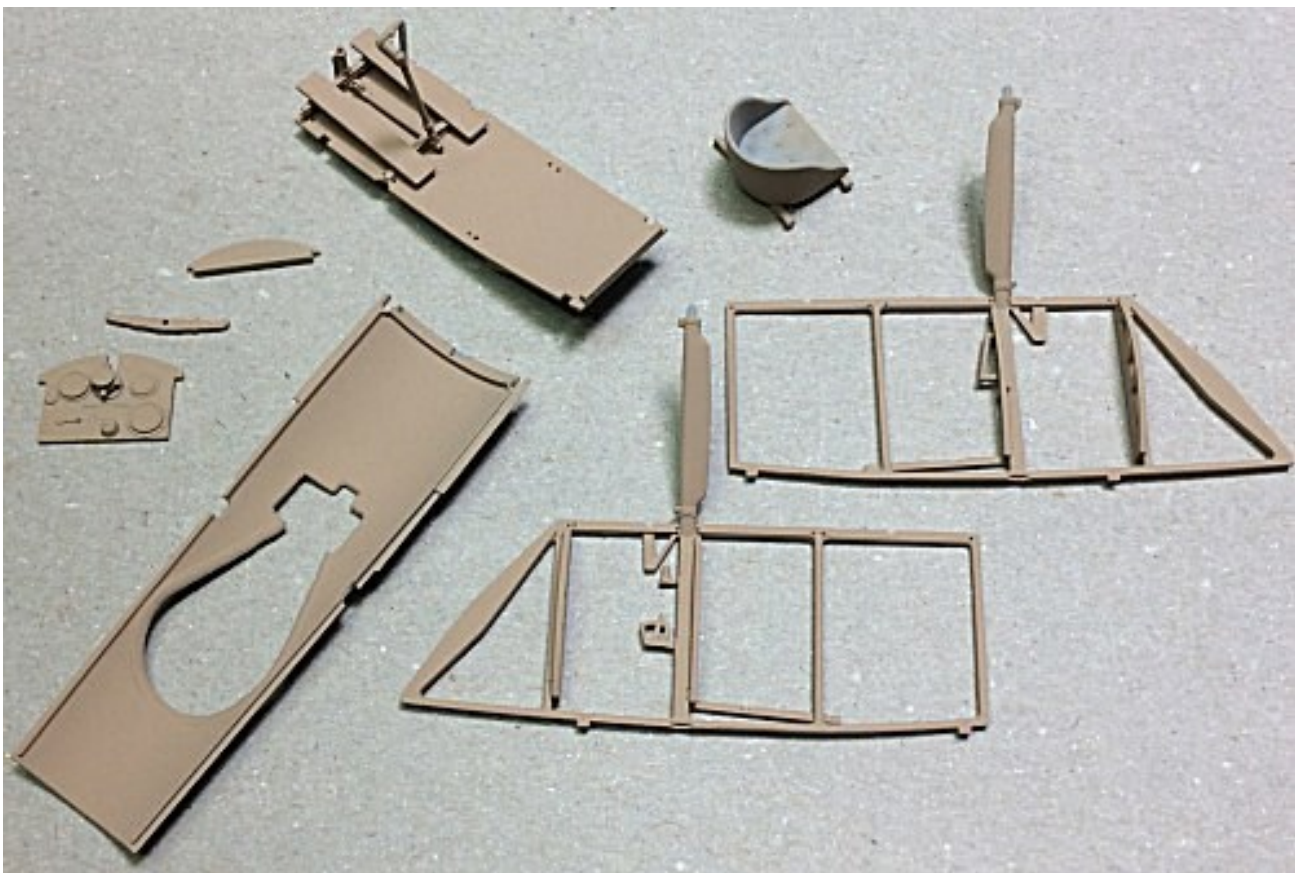

Wood effect - Method 1:

DecoArt Crafters Acrylic' paints:

For the next step I use 'DecoArt Crafters Acrylic' paints, either Burnt Umber or Burnt Sienna. These are similar to standard acrylic oil paints, but are water based instead of oil based. This paint is not as thick as oil based paint and is more creamy, so can be brushed and controlled more easily. Also, as it is water based, it's easy to clean your brushes, and if really necessary, can be thinned slightly with water. In addition, the paints dry as quickly as normal acrylic paints, avoiding the disadvantage of using true oil paints, which can take days to fully dry.

Place a small amount of the oil paint onto a non-absorbent surface and using a suitable oil paint brush (I use a slightly curved brush), wipe a small amount of the paint onto the brush. For larger areas, such as decking or panels etc I use a small piece of fine sponge to apply the paint.

Apply the paint to the applicable item, using light strokes and in the required direction. Apply the paint along struts and across instrument panels and other smaller items. This gives variation to the wood effect and for the wing struts, is correct for the direction of the wood grain. If you apply too much paint, just brush or sponge it off immediately before it dries. Although the paint is water based, don't try to thin any applied paint with water as it will lift the paint, which builds up into clumps. If required, a second light coat can be applied. Always wait until a first coat has fully dried before applying a second coat, otherwise the first coat will 'drag' and lift from the surface.

Once painting is complete, clean the brush in water.

Below is an example of the Burnt Sienna oil paint applied to a cockpit side frame.



Wood effect - Method 2:

Windsor & Newton' Griffin (Alkyd) oil paints:

NOTE: *The wood effects can also be achieved using 'Windsor & Newton' Griffin (Alkyd) paints.*

Mask off the area as required.

NOTE: *When airbrushing 'Tamiya' acrylic paints, I thin the paints using 'Mr. Colour' Self-Levelling Thinners (400), which is commonly referred to as 'unicorn tears' or just 'MLT'.*

Airbrush the areas with 'Tamiya' Dark Yellow (XF60) or similar.

Brush a covering coat of the 'Windsor & Newton' Griffin Alkyd paint, such as Burnt Sienna, over the areas.

Leave the oil paint to settle for about ten minutes.

Decant a small amount of White Spirits or 'AMMO Mig' enamel odourless thinners (A.Mig-2019), into a suitable dish.

Dip a broad flat oil brush into the thinners then wipe the brush on a sheet of kitchen roll, which should not deposit any fibres in the oil paint.

Brush the oil paint over the area, in the desired direction of the wood grain, wiping the brush on the sheet of kitchen roll to remove residual oil paint.

Repeat dipping and wiping the brush in the thinners and brushing the oil paint until the desired density and finish is achieved.

Leave the oil paint to fully dry, which normally takes approximately 24 hours.

If desired and once the oil paint is fully dry, airbrush a semi-gloss clear coat, such as 'Alclad' Satin (ALC312-60) or similar, with a few drops of 'Tamiya' Clear Orange (X26) to give a varnished look to the finish.

Surface finish:

Once the oil paint layers have dried, the final top coats can be applied to give the final effect of varnished wood.

'Tamiya' have 'Clear' coloured Acrylic paints, which are intended to be mixed with either Flat Clear (XF86), Semi-Gloss Clear (X35) or Clear (X22), to give the required finish but with a tint of the added 'Clear' colour. I use the Clear Yellow (X24) or Clear Orange (X26) to add a varnished tint to the clear coat. If using the 'Tamiya' Clear I add 'Mr. Colour' Levelling Thinners, which does improve airbrushing and avoids pooling. Otherwise I use 'Alclad' Light Sheen (ALC-311).

Although it's a lacquer, I've found that it will accept 'Tamiya' 'Clear' coloured Acrylics without any separation, which can happen with other paints. The 'Alclad' lacquers dry fast and provide a good sealing layer over the painted surfaces. When using 'Alclad' sealing coats, the golden rule is to allow the various painted surfaces to dry fully before applying 'Alclad' lacquers.

In the following example, I added a few drops of Clear Yellow (X24) into the 'Alclad' Light Sheen (ALC -311) and thoroughly mixed it. Only add small amounts to the 'Alclad' in order to control the amount of tint you desire. I increased my airbrush air pressure to around 20 psi to airbrush the sealing coats over the various cockpit items. The first coat usually dries to a more matte finish, which I assume is due to being sprayed onto the oil paint, rather than onto straight acrylic paint. Once this first coat has dried, I airbrushed several coats of just 'Alclad' Light Sheen (ALC -311), which added not only more sealing coats, but more importantly gave the desired semi-gloss 'varnished' finish I was after.

Below is an **example** of the applied 'Alclad' lacquer/X24 mix on the propeller.



NOTE: *Once you are confident using this method of replicating wood finishes, you can vary both the colour of the acrylic base coat and tinting of the sealing coat, to replicate other types of wood used in aircraft construction.*

Once the lacquer coats are thoroughly dry, any detail painting, decals or final weathering can be applied to the parts, as required, prior to fitting them to the model.

PART 3
WEATHERING
(General)

PART 3 - WEATHERING (General)

There are many different types of weathering mediums available now to modellers of aircraft, ships, vehicles and figures, in model of any type. These weathering mediums can be washes based on enamel, clay or ink. Weather pastels, applied by sponge' as well as oil paints of various sorts are also plentiful. Some modellers have even used water colour paints, and pencils. The following are the basic weathering mediums I tend to use on most of my models.

Flory Model clay washes:

The washes I tend to use are the 'Flory Models' Clay Wash 'Grime' and 'Dark Dirt', which come in various shades and consist of a suspended and very fine clay pigment. They are brushed over the surface to be weathered and dry in around 30 minutes. When dry, use either a piece of good, absorbent kitchen roll or a soft brush to remove as much of the clay wash as you need to achieve the desired effect. Once dampened, the dried clay is re-activated and the clay wash can be removed or worked as required.

First I seal the surface with airbrushed 'Alclad' Light Sheen (ALC-311), which dries quickly. A gloss coat tends to stop the clay wash 'gripping' the surface when it is applied and it can run off or just puddle. A matte coat can cause the clay wash to 'grip' too much, making it difficult to remove or even to wash it off completely.

NOTE 1: The more glossy the applied sealing coat is, the more the chance there is that the applied 'Flory' clay wash will not spread fully, but rather form puddles or beads of wash. If this happens, add a few drops of ordinary kitchen washing up liquid to the clay wash. This will break the surface tension of the wash, allowing it spread fully.

NOTE 2: Always decant the amount of clay wash you need, rather than dipping the brush directly into the wash bottle. Dipping into the wash bottle can transfer contaminants from the brush into the wash, will can cause the wash to become thick and unusable.

NOTE 3: When a sealing coat is applied over areas treated with clay wash weathering, the intensity of the applied wash tends to darken. This should be considered when removing the clay wash, otherwise the final effect may appear too dark.

To apply the clay wash is just a matter of brushing all over the surface to be weathered. It doesn't matter really how much is applied as it can be left on for any period, as it is easily removed without any effect on the surface underneath. If you don't achieve your desired effect, you can wash it all off and start again. I use a soft brush, which has been very slightly dampened, to brush off the clay wash. For smearing effects, a very slightly damp brush or absorbent paper should be used, but even then I dab them onto a dry piece of the paper, until it's almost dry. Any wetter and you'll find that you are removing too much of the clay wash. If that happens you would have to re-apply the wash and start again. That said, if you're not happy with the final effect, you can easily remove the clay wash by brushing with a wet brush or even airbrush water over the surface. Dry off the surfaces washed and then re-apply the clay wash and try again until you are satisfied. The technique is to 'damp' brush or wipe over the surface to re-activate the clay wash and at the same time, to smear it over areas that had no clay wash. It'll dry more or less straight away. Then I'll very lightly brush and/or use a piece of damp absorbent paper to remove as much as I want until I get the desired effect. If I remove too much I just reapply clay wash to that area and repeat the removal procedure. Once finished, just run the brush under a tap to rinse out any residual clay pigments. Finally I usually seal the surface with airbrushed 'Alclad' Light Sheen (ALC-311), which will seal in the applied clay wash.

NOTE 4: 'Flory' current range of washes are: Dark Dirt, Grime, Black, Light (white), Mud, Sand, Rust and Concrete. All of these washes can be used as-is or mixed to create many colour shades for weathering.



Chipping effects:

To give the effect of chipped and weathered paint/varnish to metal engine cowls and forward fuselage panels etc, chipping fluids can be used. To achieve this effect, first prime the areas with a suitable primer then airbrush the metallic finish desired. Once dry, a chipping fluid, such as 'AK Interactive' Medium Chipping fluid or 'Vallejo' chipping fluid is airbrushed over the painted areas. An alternative is to use a cheap hair spray. This forms a barrier which will allow the top coat to be chipped off. Finally the required top coat colour is applied.

Once fully dry, moisten the top coat with water, which softens the paint. Then with a cut down (stiff) brush and wood cocktail stick, gently teased off the top coat paint. Take care when doing this as 'too much chipping' can't really be covered up. In that event you would have wet the top coat and remove it all with an old toothbrush or similar and then when dry, re-spray the top coat and try again. Once the desired effect was achieved, I sealed the surfaces with an airbrushed coat of 'Alclad' Light Sheen (ALC-311).



'Tamiya' Weathering Master sets: Each of these 'Tamiya' produced weathering sets contain three 'tablets' of different colours and an applicator, which has a brush on one end and a sponge on the other. The tablets have a wax look and feel and can be applied onto painted surfaces to reproduce various finishes. It's best to use these as the final surface treatment, as being a 'Wax', any treated surfaces can't be painted or sealed.



Pigments: Pigments, such as those produced by 'Flory Models' or 'Humbrol' are effectively very fine 'dusts', which can be applied to a model to re-create dust, dirt, stains etc. They can be applied by dry brushing or mixed with other mediums to create paintable solutions.



Washes: Washes can be applied to either enhance panel lines etc or to add a 'filter' of colour onto a painted surface. They can be purchased ready made from various manufacturers or can be 'home made' using such as oil paints with a suitable thinning agent. I tend to use 'AK Interactive' products.



Water colour pencils:

Water colour pencils can be used to add weathering detail. The colour s applied to the model part then brushed gently with a brush, slightly dampened with water. This dilutes the pencil marking, allowing it to be faded as desired. 'AK Interactive' produce these 'weathering' pencils, which are marketed specifically for the modeller, although other artist water colour pencils can be used, such as 'Derwent' Inktense 24 ink pencils.



Oil paint: A technique used more frequently now is oil paint 'dot and drag'. Basically an oil paint of the desired colour is placed onto a piece of cardboard, which over a hour or so, soaks out the oil in the paint, leaving a drier pigment. The pigment is 'dotted' onto the painted surface where it is required then dragged with a brush previously wetted with 'Tamiya' X20 enamel thinners then wiped virtually dry.

Softly 'flick' the brush to drag the pigment in the direction required, which will blend it in a thin layer.

The amount of pigment left showing depends on the effect you require. Always keep the brush wiped clean to avoid a build up of pigment and remoisten and wipe dry often. The more paint you drag, the less pigment is left showing. Blending different coloured pigments can create stains from smoke/gun blast, rain marks/runs, dirt/dust and oil/fuel stains.

A good quality oil paint and thinners are essential to produce a good finish. Some quality oil paints can be too 'gritty' when leached of oil, so I use 'Abteilung 502' oil paints and 'Tamiya' Enamel thinners (X20).



PART 4
DECALS
(General)

PART 4 - DECALS (General)

Standard decals:

NOTE: *The following is **applicable only** for decals on a **painted surface**. If decals are to be placed on top of **previously applied decals**, the decal setting solutions, **if used**, may 'eat' into the previous decals. In this case a sealing coat of clear gloss, such as 'Alclad' Aqua Gloss 600, 'Mig' A-Stand Aqua Gloss (A.Mig-2503) or 'Tamiya' Clear (X22) or similar should be airbrushed over the first decals, to provide a barrier against the setting solutions.*

Ensure the painted surface is smooth and free from any surface imperfections.

Airbrush a sealing coat of 'Alclad' Aqua Gloss (600), 'Ammo' Aqua Gloss Clear (A.MIG-2503), or 'Tamiya' Clear (X22) to provide a smooth surface.

NOTE: *'MicroSet' solution softens the decal to allow it to conform to the painted surface. Do not attempt to move the decal too much or it may tear.*

Wet the area using a light coat of 'MicroScale' **MicroSet** solution.

Apply the decal after it has soaked in 'warm' water enough to start to loosen the decals from its carrier backing.

Carefully move the decal into the correct position.

Once the decal is correctly positioned, use a flat brush to softly brush the water out from under the decal, working from the centre of the decal out towards the edges. I then use a dry cotton bud in the same manner. Finally, wearing cotton gloves, I apply slight pressure and slide my fingers across the decal to finally push the decal onto the surface.

NOTE: *'MicroSol' solution will soften the decal to allow it to conform fully to the painted surface. The solution usually causes the decal to wrinkle, but this is normal as the decal semi-dissolves to the surface. Once the solution has been applied, never try to disturb the decal as it will tear. Leave the solution for several hours to do its job, after which the decal will return to a smooth surface, but conformed fully to the painted surface.*

Brush the decal surface with a light coat of 'MicroScale' **MicroSol** solution.

Leave the solution for several hours to fully dry and set the decal.

Once the decals have been applied and are dry I airbrush a final sealing coat of 'Alclad' Light Sheen (ALC-311) or 'Tamiya' Semi-Matt (XF35) over the decals.

PART 5

RESIN (General)

PART 5- RESIN (General)

This model contains aftermarket resin parts, as opposed to the normal plastic used. The reason for creating resin kits is that in years gone by, resin kits were able to produce much finer detail on kit parts than the plastic kit equivalents. Even today, there are many producers of resin kits and particularly after market replacement parts. However, plastic kit manufacturers have come a long way now and kits, such as those from 'Wingnut Wings' and 'Copper State' are equal to, if not better than resin kits. Manufacturers of resin kits these days tend to make kits to order or have 'limited' runs, although aftermarket parts are usually readily available. Working with resin does present different challenges to the modeller, especially if it's the first time of building a resin kit. The properties of resin differ radically to those of plastic kits. Below I have listed what I have found to be the primary differences for resin kits from plastic kits:

1. When resin kits are cast in their moulds, a release agent is applied to enable the cast resin parts to be more easily removed, which is similar to plastic kit moulding. This release agent can leave a film on the surface of the kit parts, which, if not removed, can prevent paint or adhesives from adhering to the surfaces. The easiest way to remove this film is to carefully and fully wash all of the model parts in warm soapy water, using an old, soft tooth brush, then rinse all of the parts thoroughly and leave to dry. Alternatively wipe the parts with isopropyl alcohol (e.g. 'Tamiya' X20A thinners).
2. Resin, by its nature, is very brittle and can be damaged or broken easily, especially when handling small parts. This is particularly evident when separating the individual items from the resin cast. The best way to remove item is to cut them away with a razor saw, then clean them up afterwards.
3. Once removed from the resin cast, parts will normally have 'resin flash' around or amongst parts, especially small items. This is easily removed with a sharp scalpel blade. Heavier residue can be scraped, filed or sanded away.
4. Plastic kits are assembled using solvent adhesives, which melt the surface where it is applied and 'weld' the joint together. Resin however will not react to this type of adhesive and can really only be glued using CA adhesive. This adhesive reacts to moisture in the air and on the surface to be joined. As most people know, it will also bond skin to whatever it touches, if the skin has CA adhesive on it. Obviously extreme care needs to be exercised when assembling resin kits using CA adhesive.
5. Cutting, sanding and drilling resin will create swarf and more importantly, resin dust. The dust in particular is dangerous, especially if inhaled. Therefore always vacuum the working area, and yourself, regularly. If you have a face mask or filtered respirator and find you can wear it whilst working, then do so. Resin can easily be drilled or scraped, but remember how brittle resin is when it is being handled.
6. It is not unusual to find imperfections in resin cast parts, such as surface blemishes, small 'blow' holes or ragged edges. This can be common on some resin kits. These imperfections can be rectified by sanding/polishing and/or filling with modelling putty, then sanding/polishing.
7. Generally CA adhesive is supplied as 'instant bond' adhesive, but there are some manufacturers, such as 'VMS Fleky', that supply CA adhesive as standard, thin, slow and specific resin adhesive. Whichever adhesive is used you must ensure parts are correctly positioned and aligned before applying the adhesive. Trying to separate mis-aligned parts once the adhesive sets will prove very difficult and may result in irreparable damage to the parts.

NOTE: To separate resin parts from the thin moulding backing sheet, use sharp scissors or a scalpel blade. To separate larger parts from the moulding base block, use a fine modellers saw. The saw I use has a double sided and fine 'drag' saw blade and with its holder is available from 'RB Productions'.

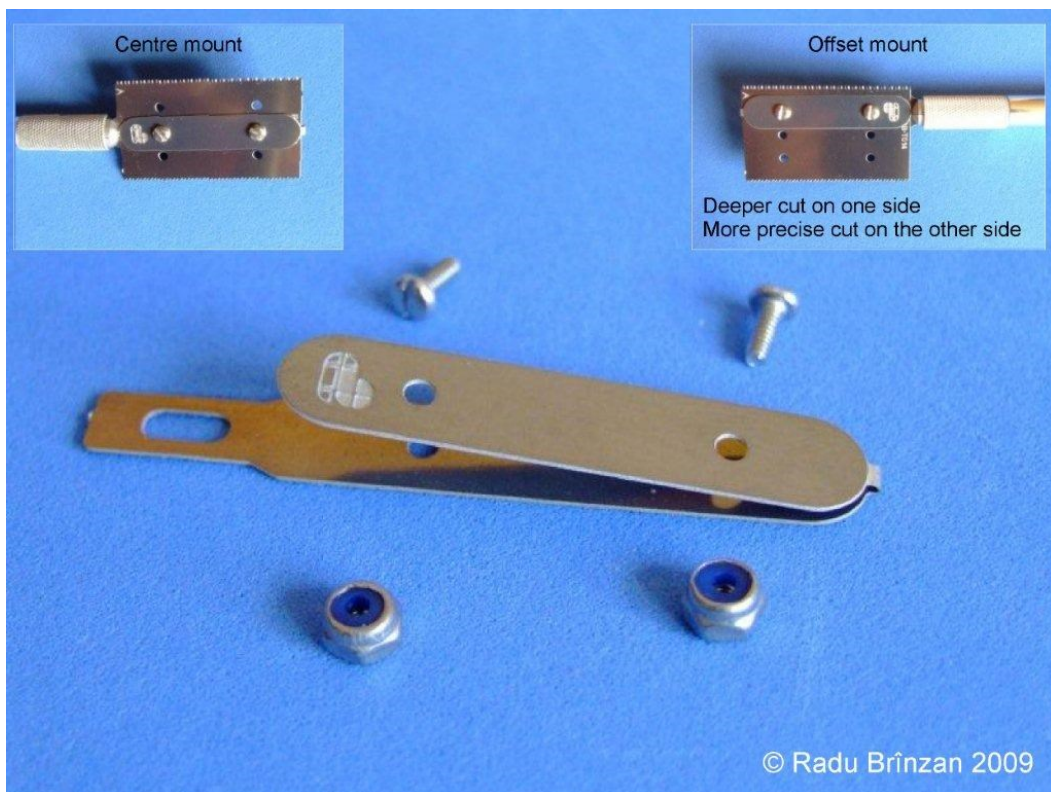
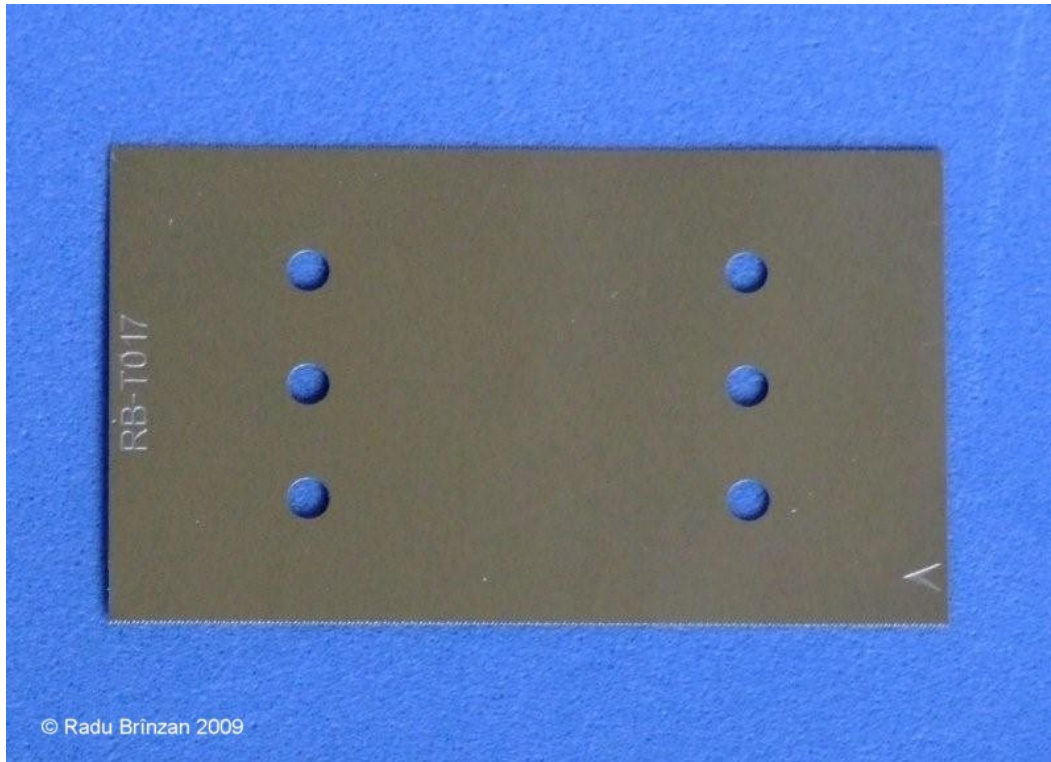

PART 6
RIGGING
(General)

PART 6 - RIGGING (General)

References:

Windsock Date file No.12 - Hanriot HD.1 (by J.M Bruce).

General:

It's important to check where the various rigging attachment points are for this aircraft. Most models have these located on the model, but it's best to carry out research in reference books or research on line before drilling. Some modellers use micro drills manufactured for drilling printed circuit boards etc and these drill bits sometimes have identifying coloured collars fitted to the drill shanks. I have found that care needs to be taken when using these drills, as they are sharp and instead of easing their way into the plastic of the model, they tend to bite in and effectively 'cork screw' their way in, which causes jamming and lots of broken drills. This is not only expensive but can leave broken drill bits in the model, which are virtually impossible to extract. An alternative is to use High Speed Steel (HSS) drill bits, which are cheaper and have less 'bite' when in use, although again, they are very fragile and can very easily be broken. Some modellers drill through the wings etc of the model and rig by pulling through the rigging line/EZ thread etc, gluing in position and then rubbing down the exposed line 'tag' and then re-painting that area. I prefer to drill only part way into the plastic and attach the applicable rigging fixture with CA adhesive.

With your research complete the rigging can be planned for the model in the subsequent Parts of this build log.

For the primary rigging, such as flying and landing wires and cross bracing wires, I used 'Steelon' or 'Stroft GTM' mono-filament (fishing line) of 0.12 mm diameter and for flight controls and 0.08 mm for flight control cables. These are effectively transparent but do give a look of steel, without the need of painting or colouring with a gel pen. The turnbuckles used are either sintered metal or resin and obtained from such as 'Gaspach Models' or 'Proper Plane'.

A good reference for this aircraft are the photographs of James Fahey, which can be found at the following web site URL.

<https://jamesfahey.smugmug.com/Hanriot-HD1/>

Internal rigging:

NOTE: *Refer to the following illustration and photographs for bracing wire locations.*

Cockpit side bracing wires:

Crossed bracing wires were fitted between the bays on the cockpit side frames. The bays closest to the engine bulkhead had twin bracing wires fitted between the top front and bottom rear of the bays. A wood bracing beam was fitted across the opposite corners.

The second and third bays from the engine bulkhead had single crossed bracing wires fitted between the bay corners.

Turnbuckles were fitted towards the bottom ends of each wire.

Cockpit floor bracing wires:

Crossed bracing wires were fitted across the cockpit floor, between the bottom corners of the cockpit side frames. Turnbuckles were fitted towards the rear ends of each wire.

Cockpit frame bracing wires:

Crossed bracing wires were fitted across the cockpit, between the corners of the cockpit side frames at the rear of the pilots seat. Turnbuckles were probably fitted towards the top ends of each wire.

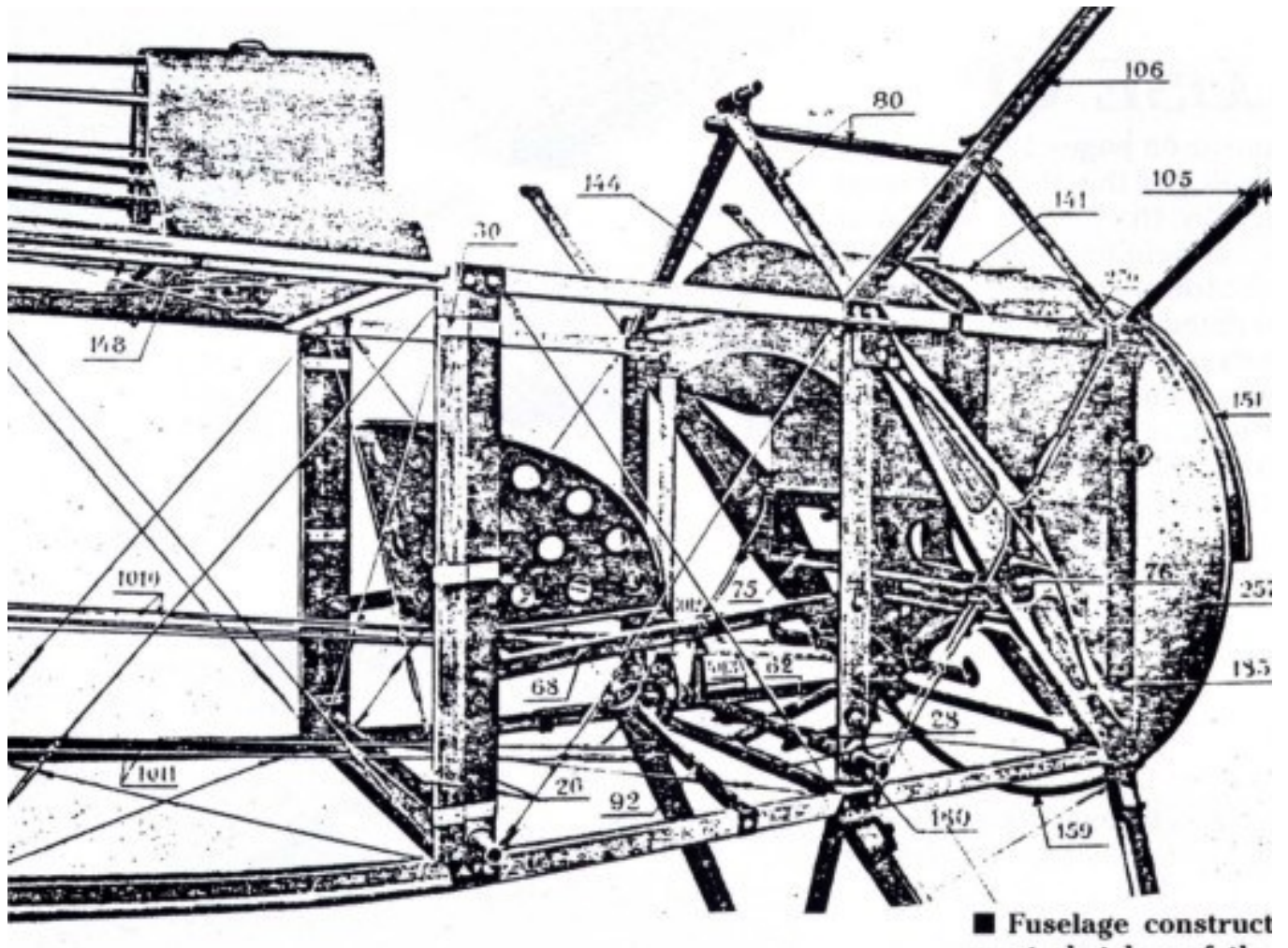

Rudder control cables:

Twin rudder control cables were fitted to each side of the pilots rudder bar. The cables were routed rearwards and out through ports in the rear sides of the fuselage. The cables were attached to the rudder control horns on the sides of the rudder.

As the pilot pushed the rudder bar left or right, the cables would move the rudder to one side or the other, causing the aircraft to turn (yaw) in the required direction.

Turnbuckles were fitted in each cable at the pilots rudder bar.

Aileron control cables:

Single aileron control cables were fitted to a bell crank at the bottom of the pilots control column. The cables were routed out through the fuselage sides and through the lower wings. From there the routing of the cables is explained in the 'external rigging' section of this chapter. As the pilot moved the control column left or right, the cables would move the ailerons in the upper wing, causing the aircraft to bank (roll) in the required direction. Turnbuckles were fitted to each cable at the pilots control column.

Elevator control cables:

Twin elevator control cables were fitted above and below the base of the pilots control column. These cables were routed rearwards through the fuselage and attached to upper and lower levers on the torsion bar of the elevator. As the pilot moved the control column forwards or rearwards, the cables would move the elevator, causing the aircraft to climb or dive (pitch) in the required direction. Turnbuckles were fitted to each cable at the pilots control column.

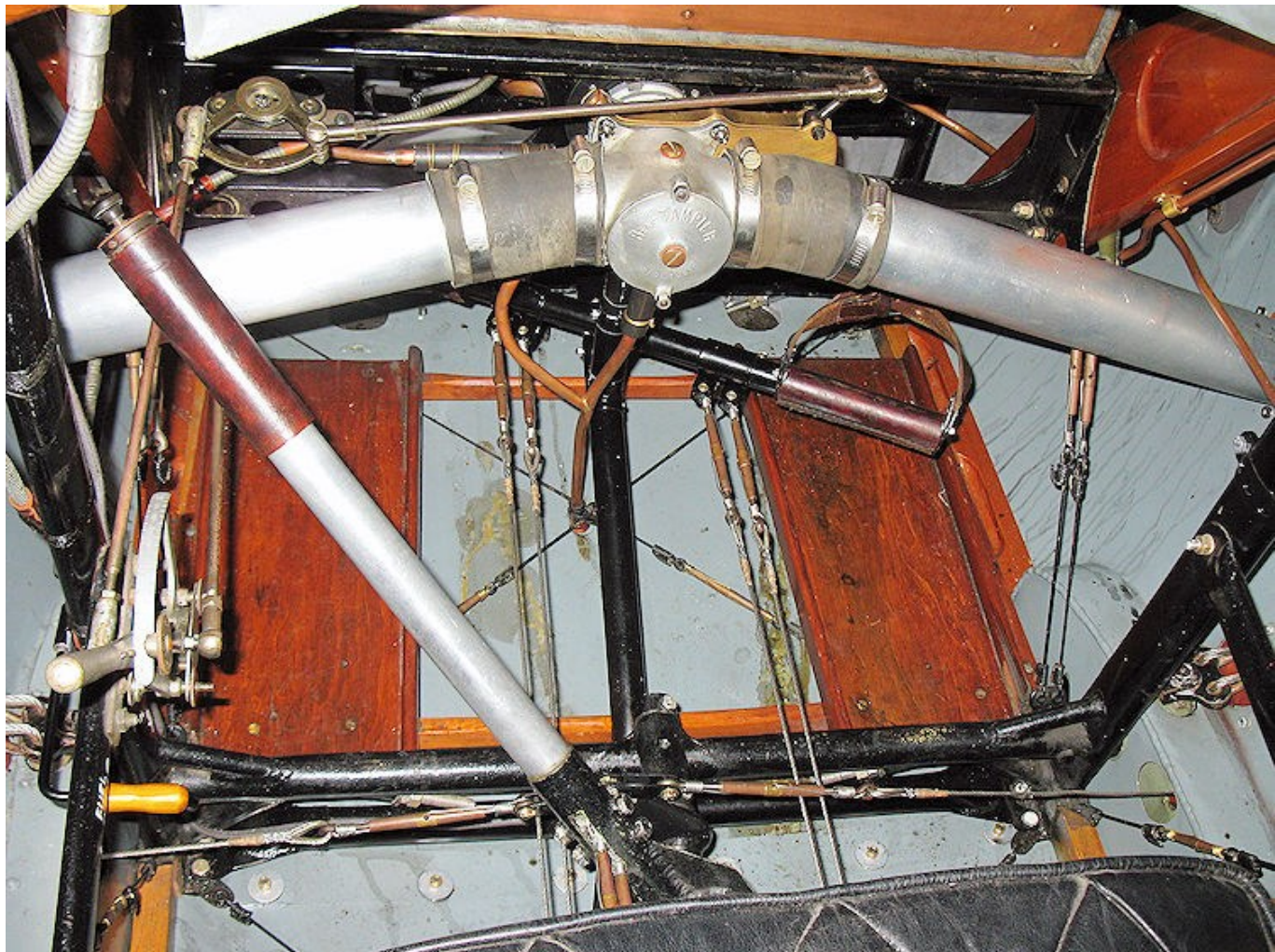

External rigging:

Twin flying wires:

Twin flying wires were fitted between the lower fuselage, above the forward landing gear strut and leading edge of the lower wing. These cables were routed diagonally up and attached to the underside of the upper wing, inboard from the interplane struts. Turnbuckles were probably fitted to the cables within the fuselage as they are not visible externally.



Single landing wires:

Single landing wires were fitted on the underside of the upper wing at the forward and rear fuselage cabane struts and routed diagonally down to inboard from the front and rear interplane struts on the lower wing. Turnbuckles were fitted to the wires at the interplane ends of the wires.



Interplane strut incidence wires:

Single crossed incidence wires were fitted between the bottom of the interplane struts on the lower wings and the top of the struts on the underside of the upper wing. Turnbuckles were fitted at the bottom of the wires.



Landing gear bracing wires:

Single crossed bracing wires were fitted between the inboard top of the landing gear forward struts and diagonally down to the bottom front of the landing gear forward struts. Turnbuckles were fitted to the wires at the top of the wires.

Additionally a bracing cable was fitted across the front edge of the axle and attached to the brackets at the ends of the axle. A turnbuckle was fitted in the centre of the cable.





Fin bracing wires:

Single bracing wires were fitted on both sides of the aircraft, between the rear of the fin down from the top of the fin post to the top, rear edge of the tailplane at the outer hinge. Similar wires are fitted to the underside of the tailplane rear edge and routed down to the bottom of the king post at the fuselage rear. Turnbuckles were in the tailplane ends of the wires.





Rudder control cables:

The twin rudder control cables from the cockpit rudder bar exit the rear sides of the fuselage and are attached to the rudder control horns on both sides of the rudder. A separate bracing wire was attached to the rear of the rudder control horns and routed up and through the rear edge of the rudder. Turnbuckles were fitted to those wires at the rudder control horns.





Elevator control cables:

Cables from the control column are attached to control levers on the elevator torsion bar.

Aileron control cables:

The aileron control cables from the cockpit and through the lower wings exit through the top of the lower wings, outboard from the forward interplane struts. The cables were routed up and rearwards to a bracket on the underside of the ailerons. From the bracket a bracing cable was routed rearwards and attached to the rear edge of the ailerons. A similar cable was attached between the rear edge of the top surface of the aileron and the rear edge of the aileron control horn. A control cable from the front of the control horns was routed forwards and into the upper wing and across the upper wing to be joined together.

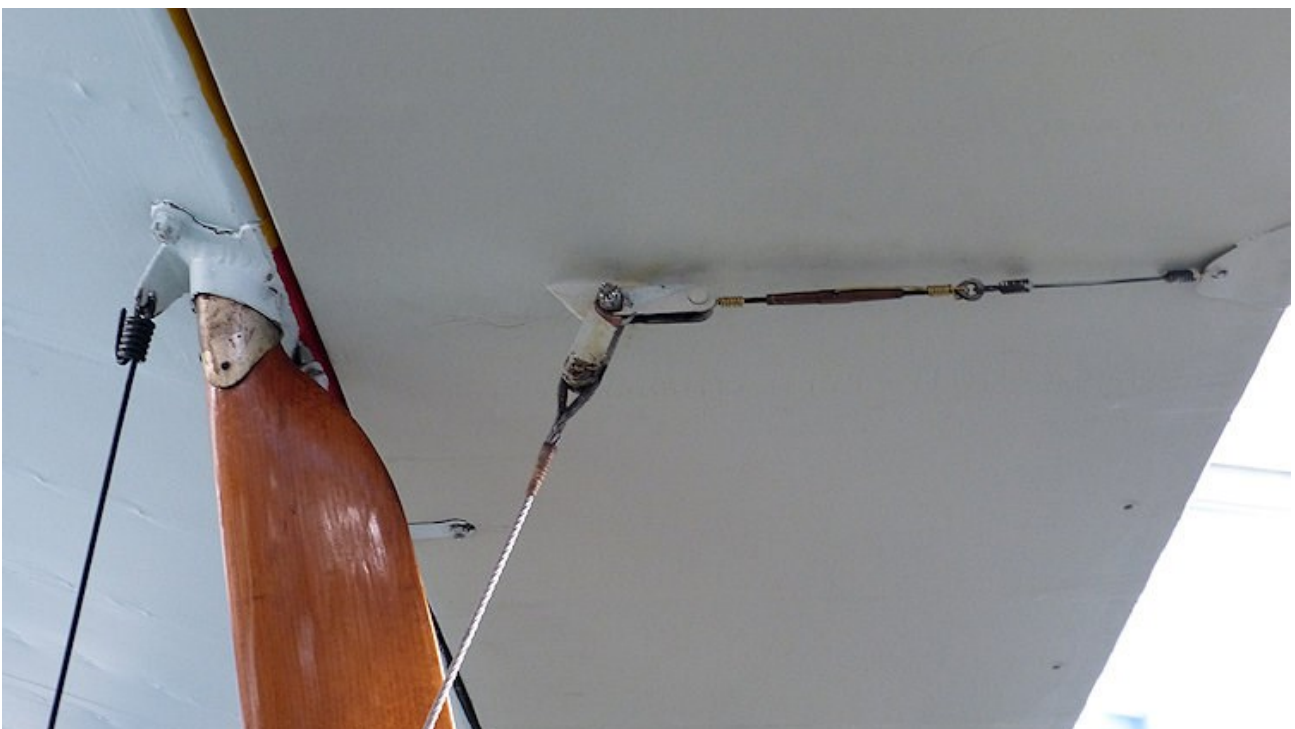



PART 7

ENGINE

PART 7 - ENGINE

The Hanriot HD.1 was powered by the Le Rhône 9J rotary engine (109hp) rotary engine. The engine supplied in the kit is totally 3D printed and to a good surface finish with very little obvious striations, that can be associated with 3D printed components. However, there are no valve push rods supplied and ignition leads need to be added.

Preparation:

NOTE: *As this 3D printed engine is resin, assembly must be done using **CA adhesive**.*

The resin used to print the parts is brittle. Therefore, care is needed when removing the parts from their print supports and when subsequently when handling. Spare parts are supplied but only nine cylinders and induction pipes are required.

Assembly:

Carefully sand away any stubs on the parts from the 3D support trees.

Secure the nine cylinders to the engine block. Make sure the cylinders are fitted in the correct orientation (refer to the instructions illustrations).

Painting:

Airbrush the engine assembly and the nine induction pipes with a grey primer, such as 'AK Interactive' Grey (AK758) or similar.

Airbrush the engine assembly with steel, such as 'Alclad' Steel (ALC-112) or similar.

Airbrush the nine induction pipes with a mix of 'Alclad' Copper (ALC-110) and Gunmetal (ALC-120) or similar.

Weathering:

Brush 'AK Interactive' Kerosene wash (AK2039) over the engine.

Lightly brush 'Tamiya' Weathering Master Set D (Burnt Blue) around the tops of each cylinder.

Painting (continued):

Brush paint the spark plug in each cylinder with 'Tamiya' Deck Tan (XF55) or similar.

Modifications:

Valve push rods:

NOTE: *Use 0.4 mm diameter Nickel-Silver tube (e.g. 'Albion Alloy's' NST04 or similar). The tube is easy to roll cut under a straight scalpel blade which leaves no burr at the cut end.*

Drill a hole of 0.5 mm diameter into each of the nine push rod recesses, behind the cylinders.

Cut a length of 0.4 mm diameter long enough to be located into its pre-drilled hole in the engine block, then lifted slightly to rest against the underside of the valve lever on the top of the cylinder.

Locate the tube in position and secure in position.

Repeat to add tubes, representing the valve pushrods, to the remaining eight cylinders.

Ignition leads:

Cut nine lengths of 'EZ' Black stretch line (Fine).

Using thin CA adhesive, secure one end of a line to each of the nine spark plugs in the engine cylinders.

Stretch each line slightly and secure to the rear edge of the crankshaft housing and at an anti-clockwise position.

Assembly (continued):

Secure the nine induction pipes in position. The bottom of each pipe locates into the recess at the rear, base of the cylinders and the top of the pipe locates against the inlet 'flat' on the cylinder head.

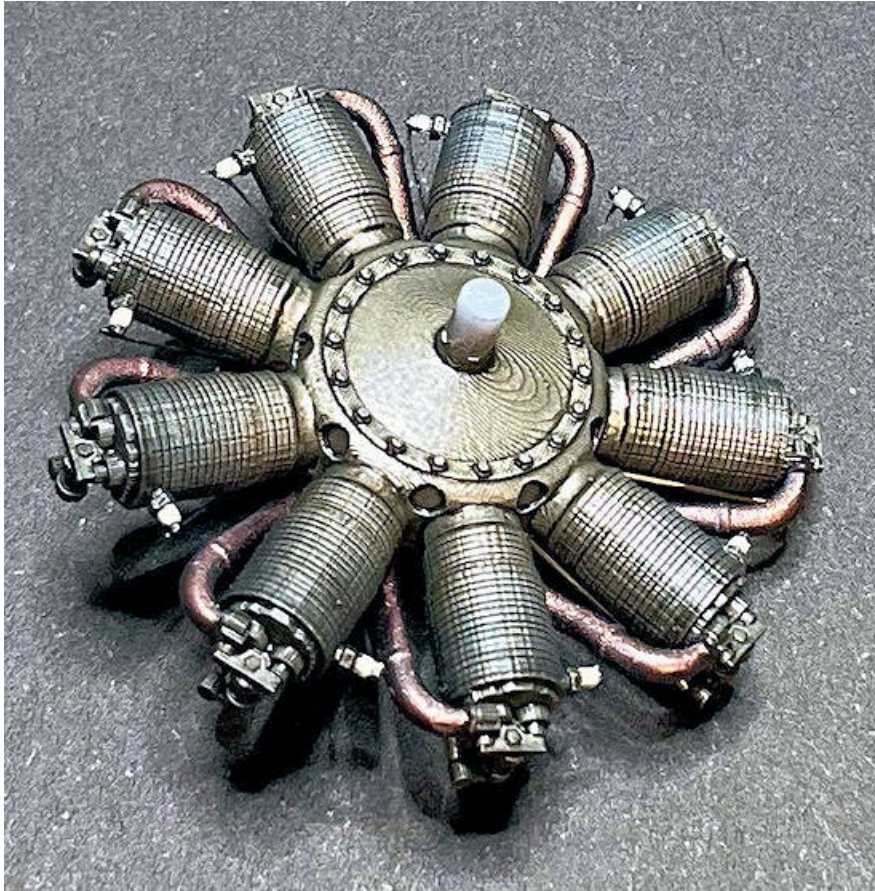

PART 8

WEAPON

PART 8 - WEAPON

The Belgian Hanriot HD.1 aircraft were normally fitted with a single Vickers 0.303 (7.7mm) machine gun, mounted either centrally on the fuselage in front of the cockpit or offset to the left side at the fuselage cabane struts. However, in June 1918, Willy Coppens had the Vickers 'Balloon Buster' (11mm) machine gun fitted to his Hanriot HD.1, as he found that weapon to be more effective against German observation balloons, which were his favoured targets.

As such the machine guns supplied with the kit were discarded and the Vickers 'Balloon Buster' from 'Gaspatch Models' (13-32042) was used instead.



Preparation:

NOTE: As this weapon is resin, assembly must be done using **CA adhesive**. The resin used is brittle. Therefore, care is needed if separating parts and subsequently when handling.

This weapon modification was carried out after the fuselage was built in Part 10 (Fuselage) of this build log.





NOTE: After fitting the two fuel caps it was found that they protruded too far and stopped the weapon from locating onto the fuselage correctly.

File or sand across the top of the two forward filler caps such that their inboard edges are just above the fuselage.

Cut two short lengths of 0.4 mm diameter rod, such as that from 'Albion Alloy's' or similar.

Using thin CA adhesive, secure the rods centrally on the top of the filler caps, but not across the fuselage as that may stop the weapon from locating correctly.



Allowing for the fitting of the windscreen, hold the weapon against the fuselage decking panel and mark the location of the mounting lugs under the weapon.

Using the mark as a guide, drill a hole vertically into the fuselage decking panel.

Locate the weapon onto the decking panel with its mounting lugs in the drilled hole.

NOTE: The following modification to the weapon are necessary to allow it to locate correctly onto the decking panel and to add the kit supplied ammunition chutes.

File or sand away the areas under the weapons breach block .

Test fit the weapon onto the decking panel with its mounting logs in the drilled hole. Check that the mounting lugs can be inserted into the drilled hole and that the underside of the breach block rests on the decking panel. If necessary, remove material from the weapon and drilled hole to achieve this.

Using thin CA adhesive, secure the two kit supplied 3D printed ammunition chutes against the ammunition feed slot in the breach block.

Using thin CA adhesive, secure a cut piece of 1.0 mm thick plastic card into the recess in the weapons breach block and onto the bottom of both ammunition feed chutes.

Test fit the weapon onto the decking panel and note where the added plastic card pieces need to be filed to allow the weapon to locate fully with the bottom of the ammunition chutes in contact with the decking panel. Adjust as required.

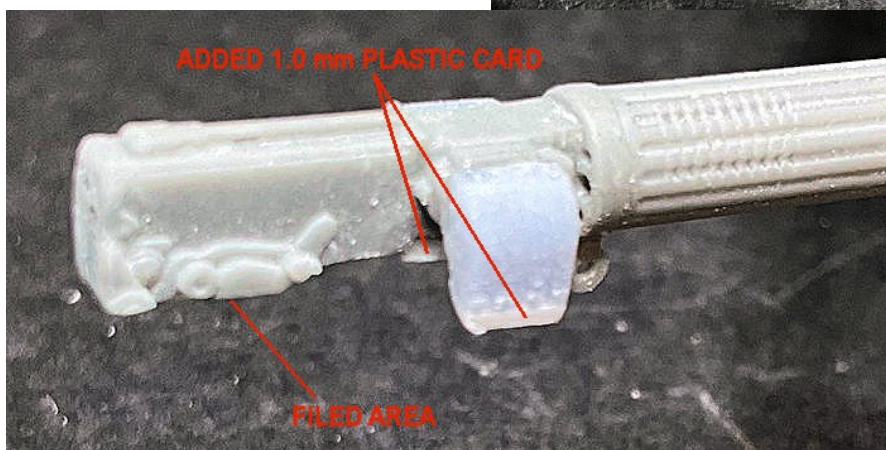
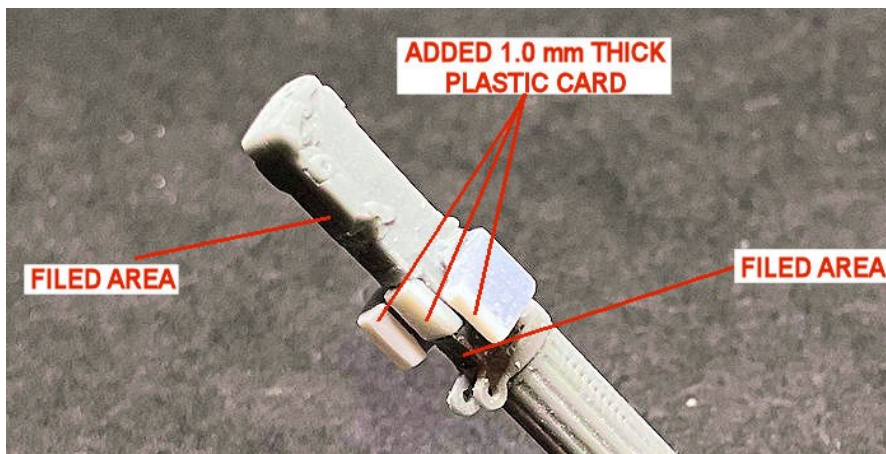

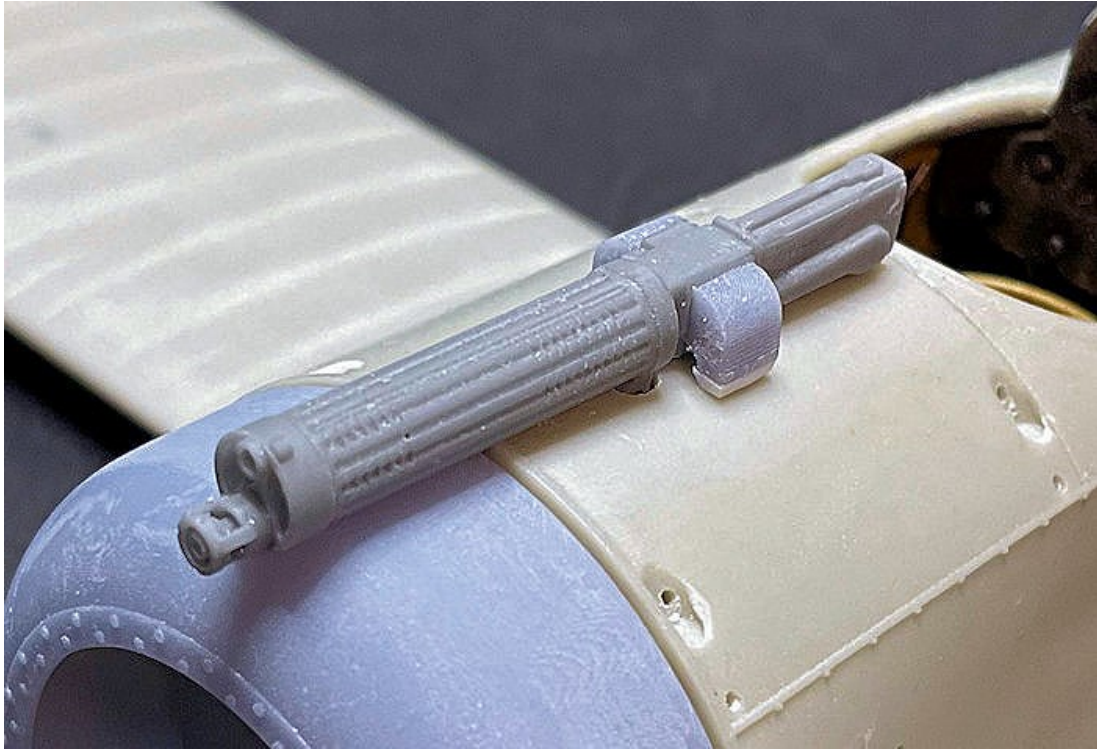

Painting:

Airbrush the machine gun with a grey primer, such as 'AK Interactive' Grey (AK758) or similar.

Airbrush the machine gun with a gloss black, such as 'Tamiya' (X1) or similar.

Airbrush the machine gun with 'Alclad' Gun Metal (ALC-120) or similar.

Dry brush the machine gun with 'Mr. Colour' Super Iron 2 (SM203) or similar.



PART 9

PROPELLER

PART 9 - PROPELLER

Preparation:

Check the propeller for any surface imperfections and if necessary, fill the sand to blend with the surrounding surfaces.

Painting:

Airbrush the propeller with a grey primer, such as 'AK Interactive' Grey (AK758) or similar.

Airbrush the propeller with a mix of 70% 'Tamiya' Flat Red (XF7) and 30% of Hull Red (XF9), thinned with 'Mr. Colour' Levelling Thinners 400.

NOTE: Refer to Part 2 (Wood Effects) of this build log for more information. The method I used is Method 2, using 'Windsor & Newton' Griffin (Alkyd) oil paint.

Apply with a brush and smooth the paint to remove excess oil paint. I used Windsor & Newton' Griffin (Alkyd) Burnt Sienna oil paint.

Once the oil paint has fully dried, airbrush a semi-matt clear coat, such as 'Alclad' Light Sheen (ALC311) or similar.

Apply with a brush the desired wood effect, making sure the surface finish is smooth. I used Windsor & Newton' Griffin (Alkyd) Vandyke Brown oil paint.

Brush paint the propeller central hubs with 'Mr. Colour' Stainless Steel (213) or similar.

Brush propeller central hubs with 'AK Interactive' Kerosene wash (AK2039).



PART 10

FUSELAGE

PART 10 - THE FUSELAGE

References:

Windsock Date file No.12 - Hanriot HD.1 (by J.M Bruce).

NOTE: *As this model is resin, all assembly of parts must be done using **CA adhesive**. The resin used to 3D print some of the parts is brittle. Therefore, care is needed when removing the parts from their print supports and when subsequently when handling.*

Preparation:

NOTE: *The resin cast parts may have molding 'flash', rough or badly fitting joints and seams, surface artifacts, such as surface blemishes and air 'blow' holes. All of these will need to be rectified before any assembly is attempted.*

The resin 3D printed parts, once removed from the print supports, will need to have residual support tags removed.

Photo-etch parts, once removed from their sheet, should have residual tags removed.

Refer to pages 3, 4 and 5 of the kit instructions for the parts required.

Remove the required 3D printed parts required from their print supports.

Remove the required photo-etch parts required from the kit supplied sheet.

Pre-rigging:

NOTE: *Refer to Part 6 (Rigging - General) for more information on the cockpit rigging and the following illustrations.*

Cockpit side bracing wires:

Drill holes of 0.3mm diameter through the corners of the cockpit side frames. Each hole should be drilled to align with the diagonally opposite frame corner.

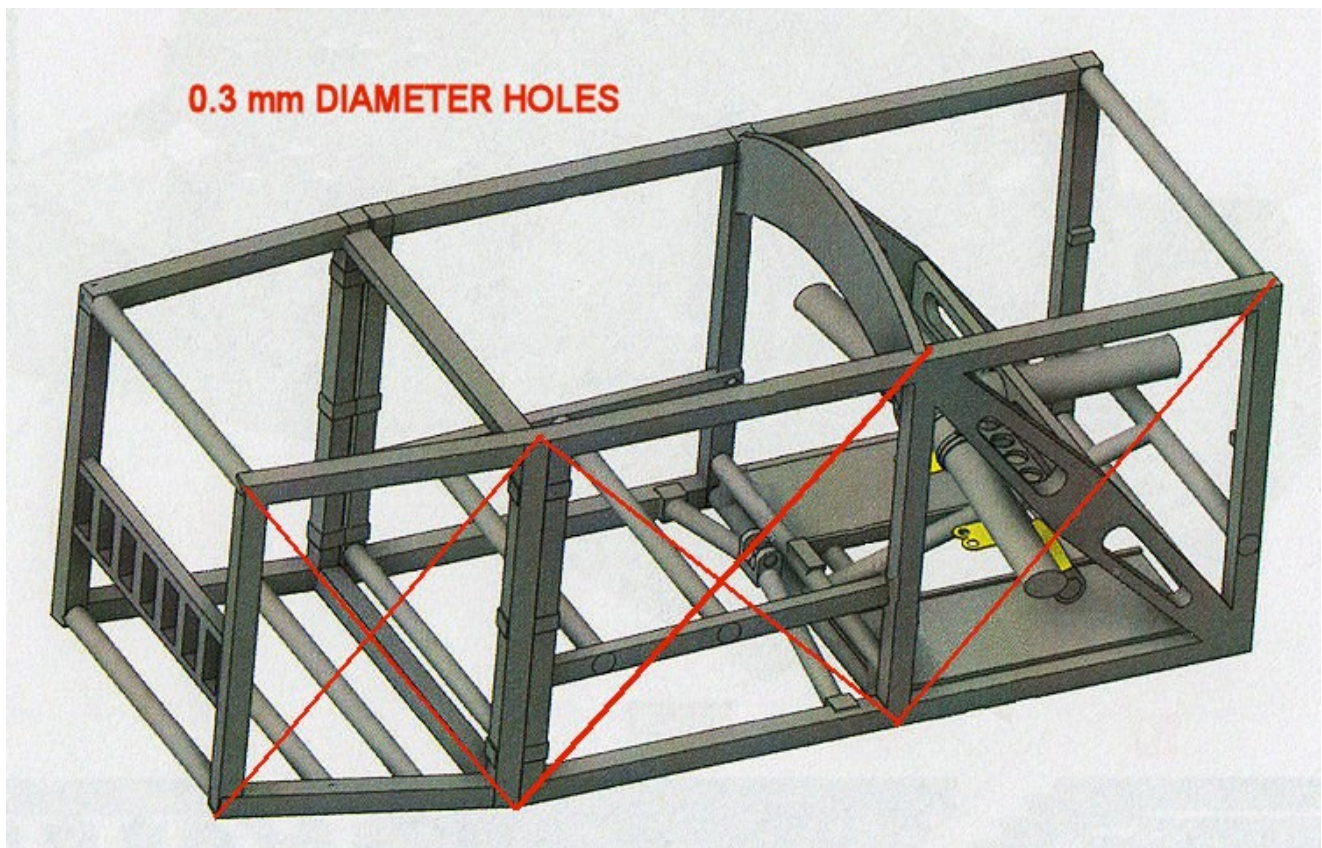

Cockpit floor bracing wires:

NOTE: *The cross bracing wires across the forward section under the foot boards do not need to be drilled.*

Drill holes of 0.3mm diameter through the bottom corners of the cockpit side frames at the two rear sections only. Each hole should be drilled to align with the diagonally opposite frame corner.

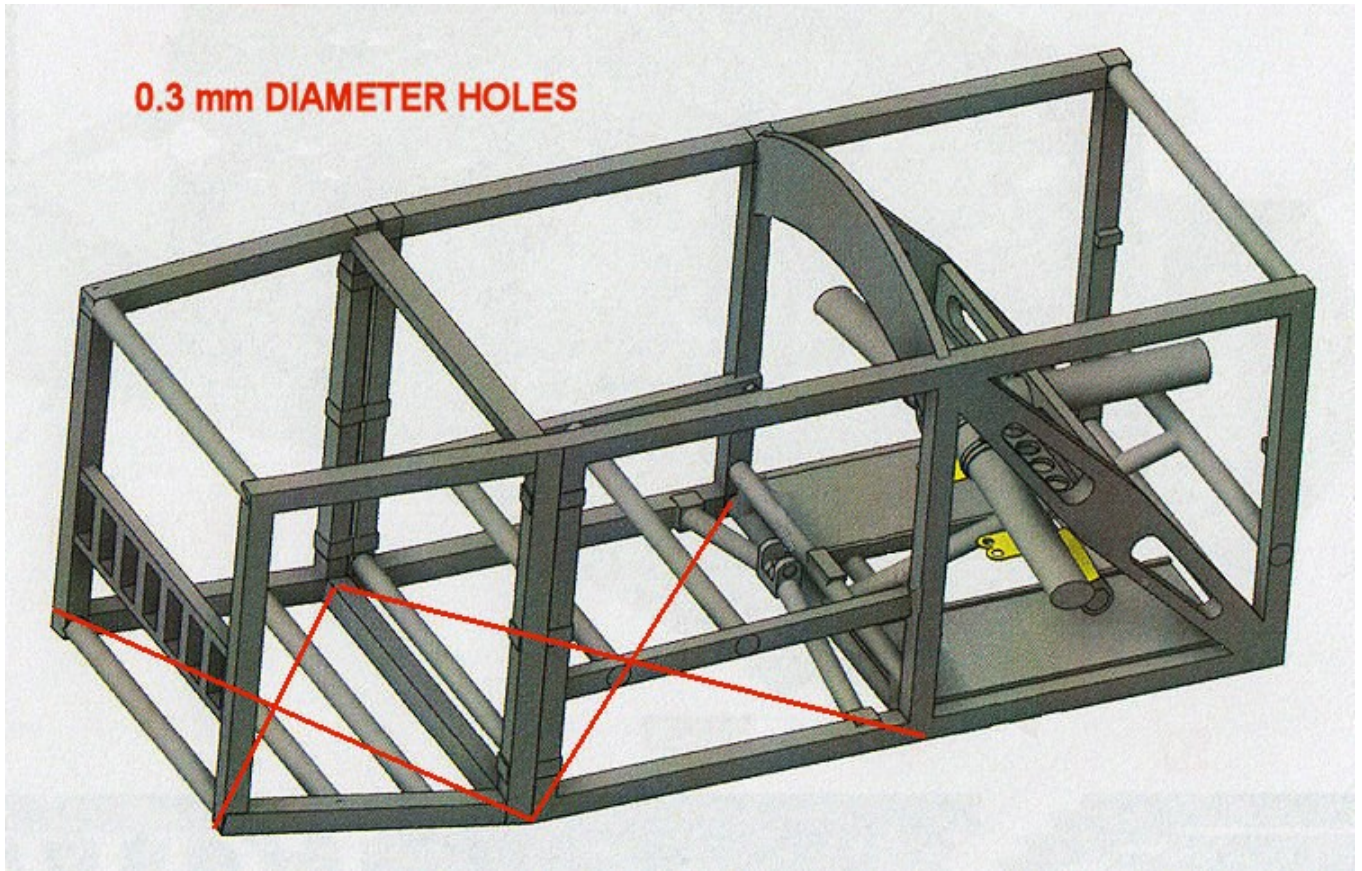

Cockpit frame bracing wires:

Drill holes of 0.3mm diameter through the corners of the cockpit frame behind the pilots seat. Each hole should be drilled to align with the diagonally opposite frame corner.

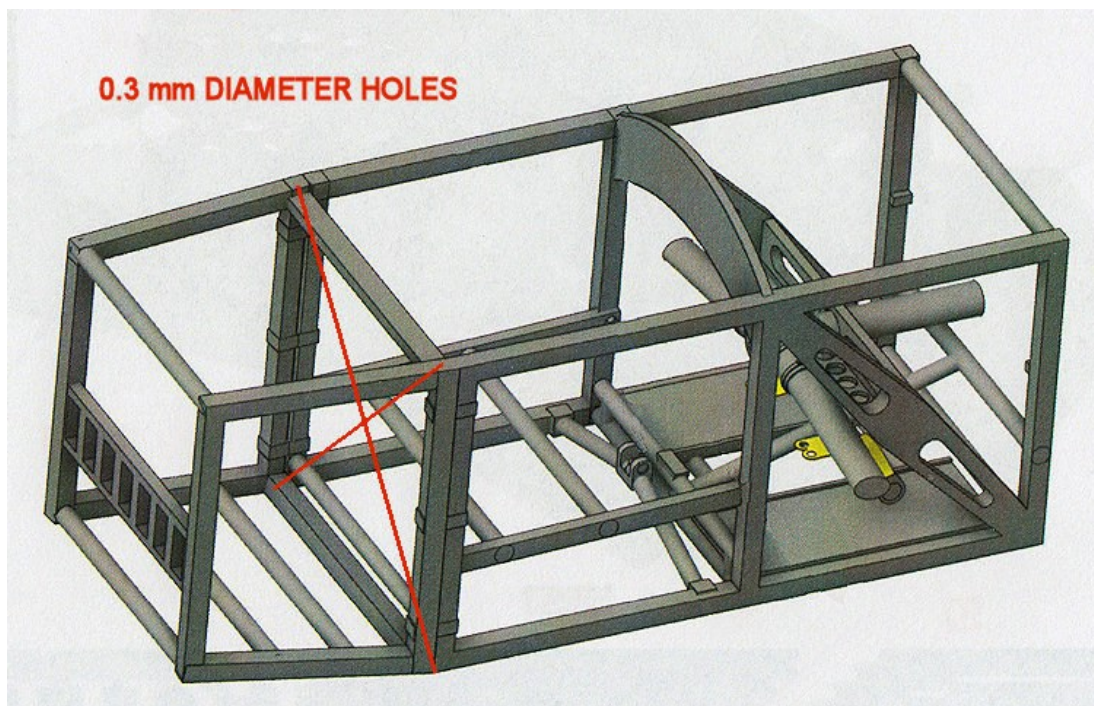

Rudder control cables:

NOTE: The kit supplied photo-etch rigging anchors for the rudder bar will not be used.

Drill holes of 0.2mm diameter through the rudder bar.

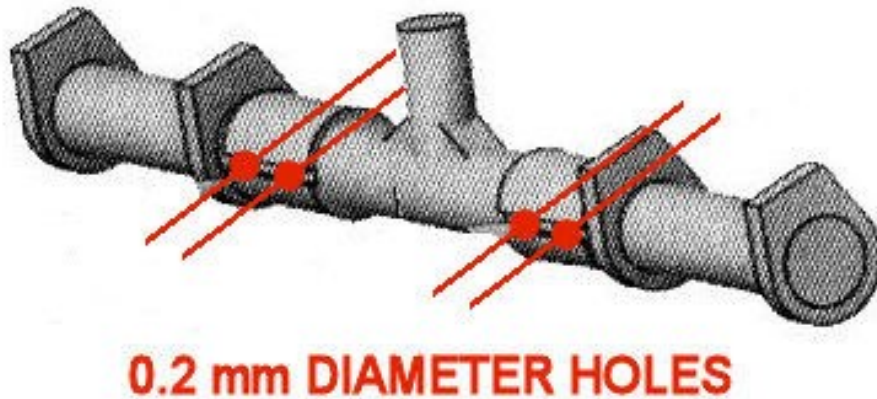

Elevator control cables:

Drill two holes of 0.2mm diameter through the lower part of the control column.

Aileron control cables:

Drill a hole of 0.2mm diameter across and through the lower part of the control column.



Locate the cockpit frame into the left fuselage half.

Point mark the inside of the fuselage half just above the cross member in the cockpit frame where the control column will be fitted.

Remove the cockpit frame.

Using the point mark as a guide, drill a hole of 0.3 mm diameter through the cockpit half, making sure the drilled hole exits the outside of the fuselage half inside the wing location area.

Repeat the procedure to the right fuselage half

Test fit the tanks assembly into the cockpit frame and onto their stops inside the frame. If necessary file or sand the outer faces of the tanks to achieve a good fit.

NOTE: *The photo-etch mounting (6) and lever (7) for the 'Pulsometer' were not used.*

Using thin CA adhesive, secure the 'Pulsometer' vertically onto its location on the right end of the instrument panel.

Painting:

Airbrush the following with a grey primer, such as 'AK Interactive' Grey (AK758) or similar:

- Inside of the two fuselage halves
- Cockpit frame assembly
- Pilots seat
- Pilots seat cushion
- Cockpit back padding
- Fuel tanks assembly
- Control column
- Rudder bar
- Carburettor air intake manifold
- Throttle lever quadrant.

Airbrush the following with 'Tamiya' Dark Yellow (XF60) or similar:

- Cockpit frame assembly
- Pilots seat
- Pilots seat cushion
- Cockpit back padding.

Airbrush the fuel tanks assembly with 'Alclad' Steel (ALC-112) or similar.

Airbrush the carburettor air intake manifold with 'Alclad' Aluminium (ALC-101) or similar.

Airbrush the following with 'Alclad' Gunmetal (ALC-120) or similar:

- Control column
- Rudder bar
- Throttle lever quadrant.

Mask off the inside forward area of the fuselage halves, vertically down from the rear edge of the cockpit opening.

Airbrush the exposed rear surface with 'Tamiya' Deck Tan (XF55) or similar.:

Remove the masking.

Mask off the painted inside rear of the fuselage halves, vertically down from the rear edge of the cockpit opening.

Airbrush the exposed forward inner surface of the fuselage halves with 'Alclad' Duraluminium' (ALC-102) or similar.

Remove the masking.

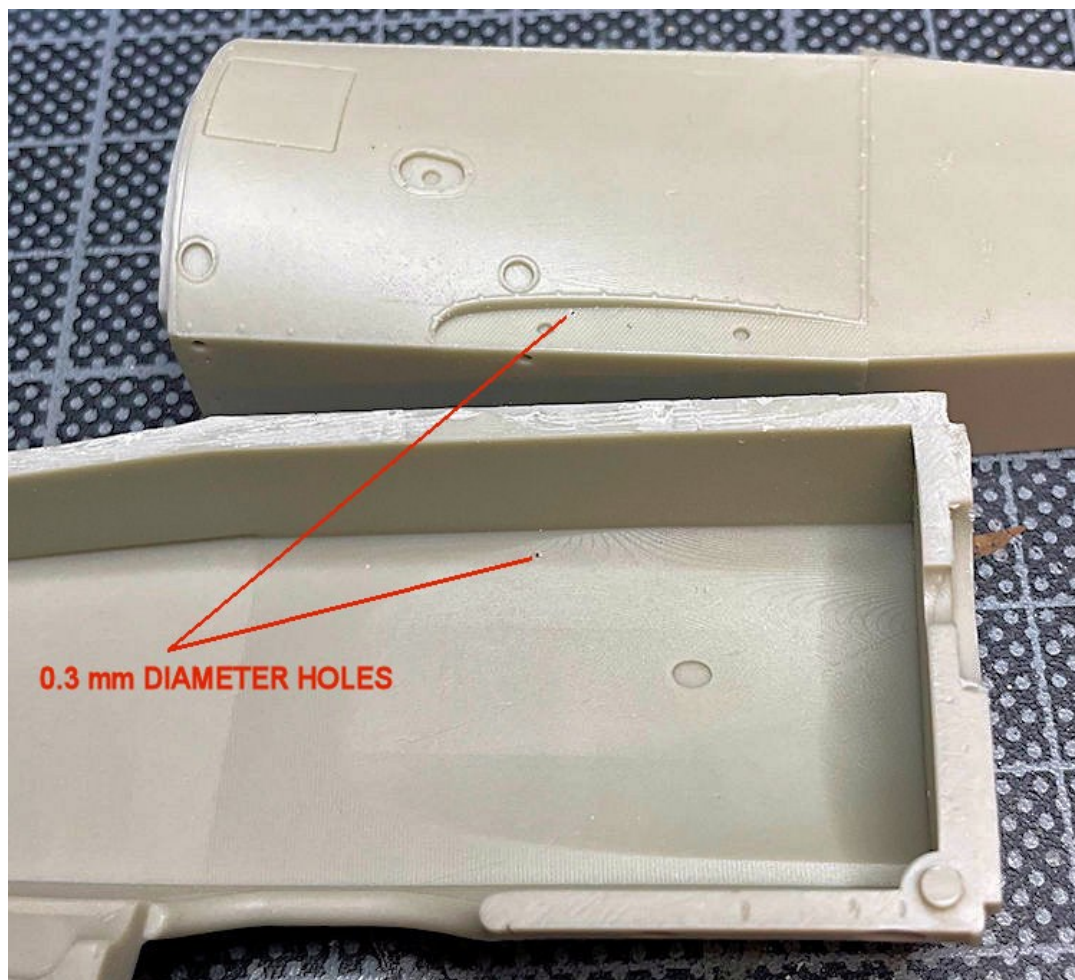

Assembly:

NOTE: Refer to pages 3 and 4 of the kit instructions for the parts required. The two foot straps (9b) for the rudder bar will not be used and replaced.

Remove the required photo-etch parts required from the kit supplied sheet.

Where possible, lightly sand the mating faces of the photo-etch parts to give a good surface for applying the adhesive.

Using either thin CA or PVA (white glue) adhesive, secure instrument plates 2a, 4a and 5a to the instrument panel (1).

Using either thin CA or PVA (white glue) adhesive, secure switch plate 3a to the to the instrument panel (1).

Using either thin CA or PVA (white glue) adhesive, secure switch plate 3b to switch plate 3a.

Test fit the instrument panel assembly onto the face of the instrument panel on the cockpit frame. If necessary use a photo-etch file or lightly sand the panel to achieve a good fit.

Using thin CA adhesive, secure the instrument panel assembly to the cockpit frame.

NOTE: The two foot straps (9b) for the rudder bar are replaced with strips cut from spare 'HGW Models' paper seat straps.

I cut thin strips from a 'HGW Models' seat strap and secured them to the ends of the rudder bar.

Bend the throttle lever (8) up and against the quadrant.

Using thin CA adhesive, secure the fuel and oil tanks together.

Wood effects:



NOTE: Refer to Part 2 (Wood Effects) of this build log for more information. The method I used is Method 2, using 'Windsor & Newton' Griffin (Alkyd) Burnt Sienna and Raw Sienna oil paint.

Dark wood effect:

The following parts require a darker coloured wood effect. I used Windsor & Newton' Griffin (Alkyd) Burnt Sienna oil paint:

- Pilots foot boards
- Forward diagonal beams.

Light wood effect:

The following parts require a lighter coloured wood effect. I used Windsor & Newton' Griffin (Alkyd) Raw Sienna oil paint:

- Cockpit frame
- Instrument panel
- Pilots seat.

Brush a covering coat of the relevant 'Windsor & Newton' Griffin Alkyd oil paint over the parts.

Leave the oil paint to settle for several minutes.

Decant a small amount of White Spirits or Odourless thinners into a suitable dish.

Dip a flat oil brush into the thinners then wipe the brush on a sheet of kitchen roll (which should not deposit any fibres in the oil paint) to remove most of the thinners.

Brush the oil paint onto the part in the required direction of the wood grain and keep wiping the brush on the sheet to remove residual oil paint.

Repeat dipping and wiping the brush in the thinners and brushing the oil paint until the desired density and effect is achieved.

Leave the oil paint to fully dry. It should be touch dry in an hour or so and fully dry within 12 hours.

Painting (continued):

Brush paint the following with 'Tamiya' Rubber Black (XF85) or similar:

- Forward cross member
- Rudder bar support tube
- Two horizontal cross members
- Interconnecting tube between foot boards.

Brush paint the following with 'AK Interactive' Brown Leather (AK3031) or similar:

- Control column hand grip
- Rudder bar foot ends and straps
- Couplings on carburettor air intake manifold.



Leather effect:

Brush the pilots seat cushion and the cockpit back padding with 'Abteilung 502' Smoke oil paint.

Brush the pilots seat cushion and the cockpit back padding with 'Windsor & Newton' Griffin Alkyd Burnt Sienna oil paint.

Lightly dampen a brush with White Spirits.

Use the side of the brush to dab the Burnt Sienna oil paint to lift the paint and create a leather look, leaving the darker Smoke oil paint in the recesses.

Leave the oil paint to fully dry. It should be touch dry in an hour or so and fully dry within 12 hours.



Assembly (continued):

Using thin CA adhesive, secure the seat cushion onto the pilots seat.

Locate the carburettor air induction manifold through its locating hole in the centre of the cockpit cross member, with the pipe ends angled downwards.

Check that with the cockpit frame located between the fuselage halves, the fuselage halves can be fully located against each other. If necessary, trim the ends of the induction manifold pipes to allow the fuselage halves to fully located together.

Using thin CA adhesive, secure the induction manifold in position in the cockpit cross member.

Using thin CA adhesive, secure the tanks assembly into the cockpit frame and onto its location steps on the cockpit side frames.

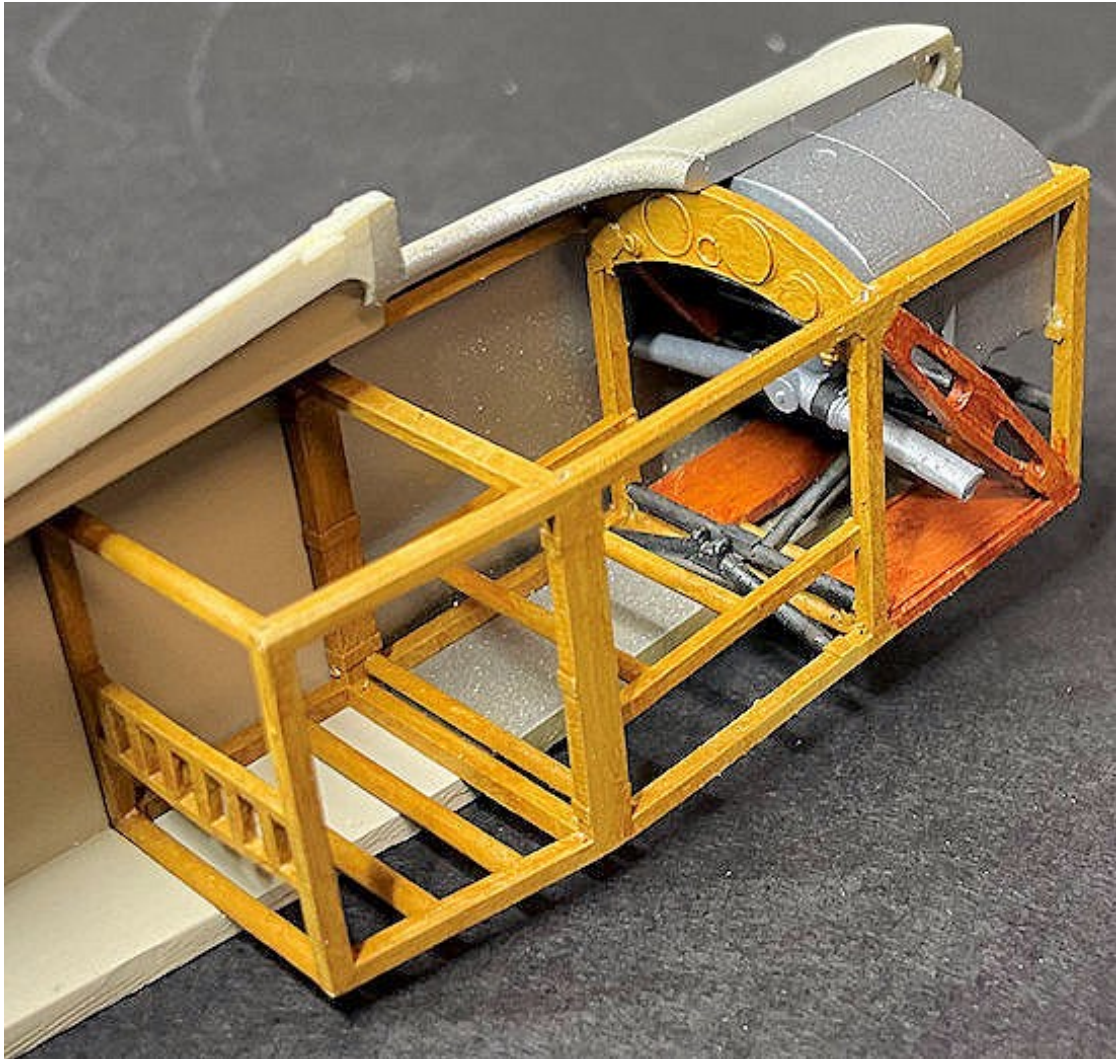

Using thin CA adhesive, secure the throttle quadrant onto the cockpit frame vertical member under the left side of the instrument panel.

Modifications:

NOTE: *Although the kit supplied parts are detailed, there are some modifications to enhance the model to better represent the actual aircraft.*

Throttle control rods:

NOTE: *Two throttle control rods were attached between the throttle quadrant and forward to the carburettor air intake manifold. One rod was routed from a control quadrant right across the top induction manifold. The other rod was routed right across and under the induction manifold.*

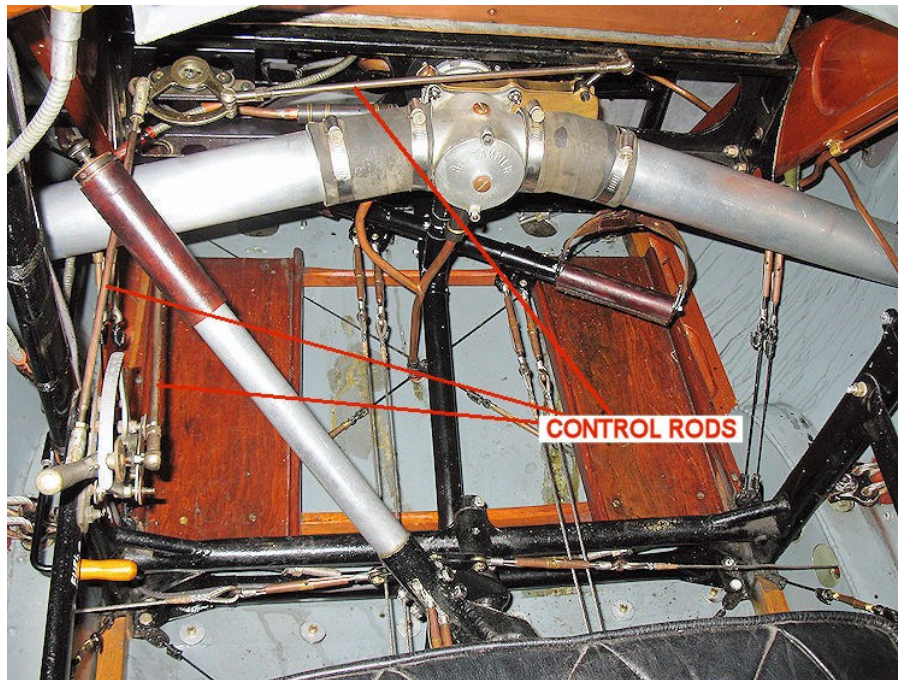

Cut two lengths of 0.3 mm Nickel-Silver tube, such as 'Albion Alloy's NST03 or similar.

Bend one tube such that it locates behind the throttle lever, then forwards and right across the air induction manifold and across to the right side of the cockpit frame.

Bend the second tube such that it locates at the bottom of the throttle lever then forwards and right across the underside of the air induction manifold.

Using thin CA adhesive, secure the two pipes in position.

'Tachometer' drive:

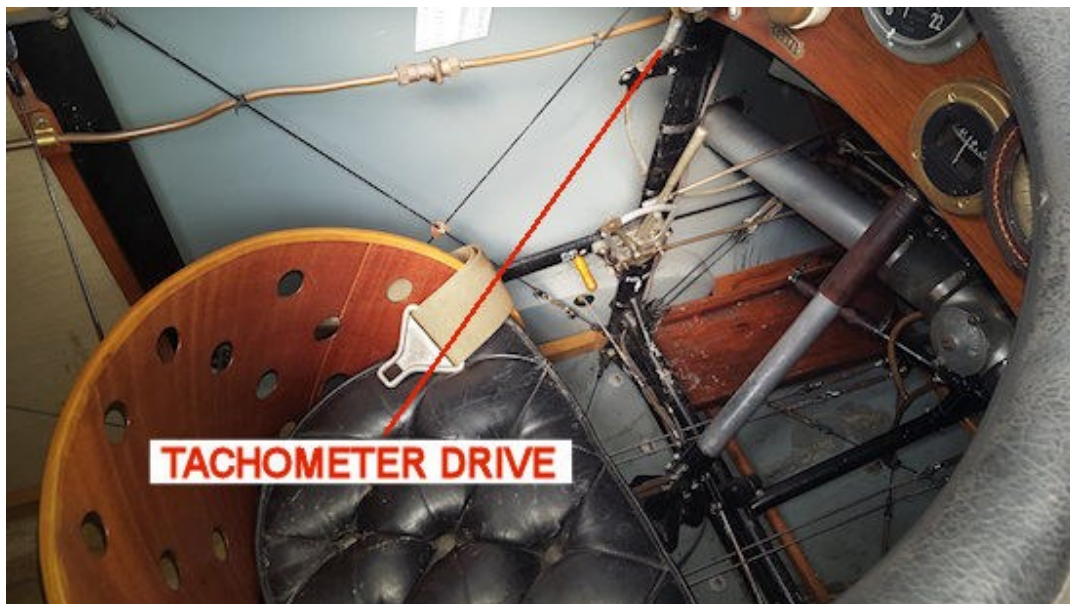

Cut a length of 'MFH' 0.4mm diameter flexible black tube (P-961).

Using thin CA adhesive, secure one end of the tube to the bottom of the 'Tachometer' on the left side of the instrument panel.

Route the tube down and around the cockpit frame then forwards inside the diagonal frame member.

Using thin CA adhesive, secure the tube to the cockpit frame.

Oil 'Pulsometer' pipe:



Cut a length of 'MFH' 0.4mm diameter flexible black tube (P-961).

Using thin CA adhesive, secure one end of the tube to the bottom of the 'Pulsometer' on the right side of the instrument panel.

Route the tube down inside the cockpit frame then forwards and to the side of the forward tank.

Using thin CA adhesive, secure the tube to the side of the tank.

Fuel level indicator:

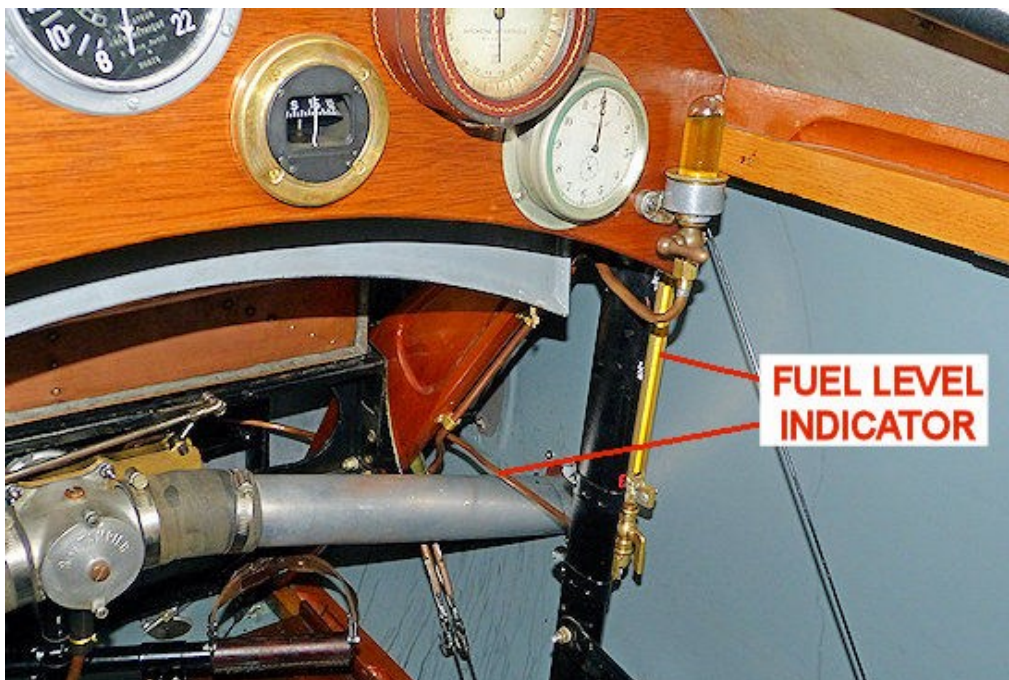

Cut a length of 0.5mm diameter Brass tube, such as 'Albion Alloy's' MBT05 or similar.

Using thin CA adhesive, secure the tube to the rear face of the vertical member of the cockpit frame below the Pulsometer.

Cut a length of 0.3 mm diameter Copper wire.

Bend one end of the wire to 90 degrees such that it will locate under the Brass tube and on the horizontal member of the cockpit frame.

Using thin CA adhesive, secure the wire under the Brass tube and on the horizontal member of the cockpit frame.

Bend the wire forwards and under the carburettor air induction manifold to the inside of the cockpit diagonal frame member.

Using thin CA adhesive, secure the tube to the cockpit diagonal frame member.

Pipe (left side):

NOTE: *The purpose of this pipe is not known.*

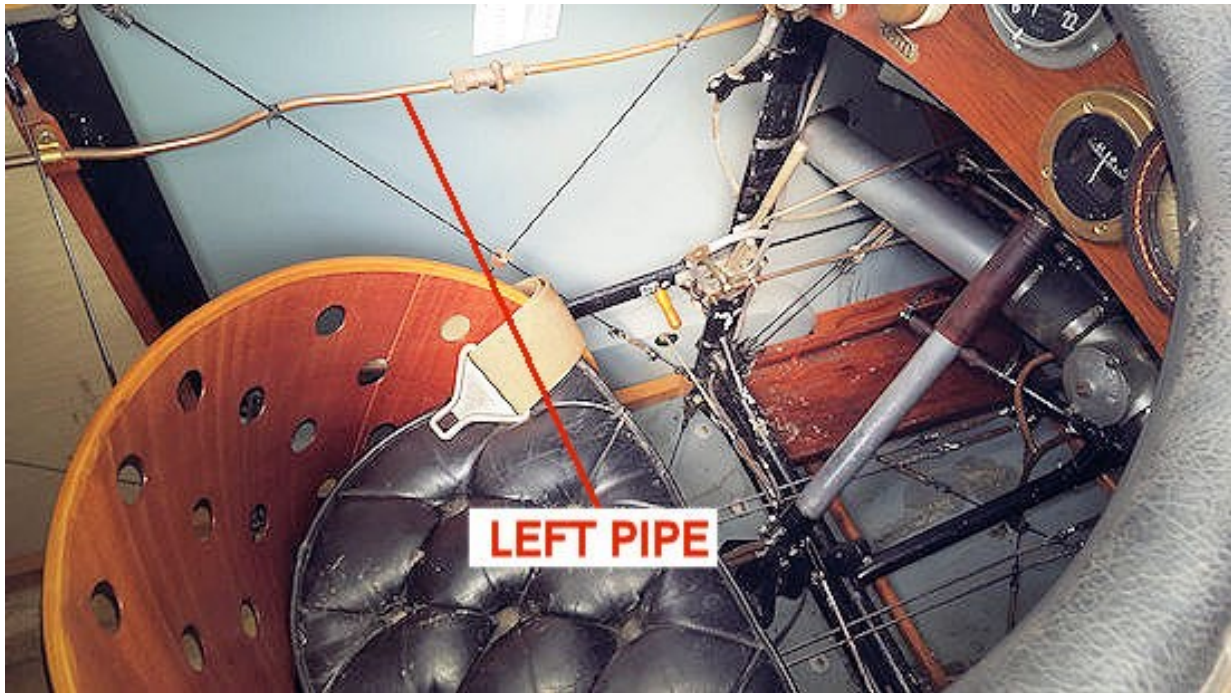

Cut a long length of 0.375mm diameter copper wire.

Using thin CA adhesive, secure the wire across the vertical members of the left side of the cockpit frame.

Painting (continued):

Brush paint the handle of the throttle lever with 'Tamiya' Hull Red (XF9) or similar.

Brush 'Tamiya' Clear Gloss (X22) over the instrument faces.

Brush paint the bulb of the 'Pulsometer' and the centre section of the Brass fuel level indicator with 'Tamiya' Clear Yellow (X24) or similar.

Brush paint the bottom of the 'Pulsometer, magneto switch and outlet of the 'Tachometer' with 'Mr. Colour' Brass (219) or similar.

Decals:

NOTE: *The kit supplied acetate decal are not used and replaced with appropriate decal from the 'Airscale' Generic WW1 instruments (AS32 WW1) set.*

Refer to pages 3 and 4 of the kit instructions for placement of the various decals.

Apply appropriate decals from the 'Airscale' Generic WW1 instruments (AS32 WW1) set to the instrument panel.

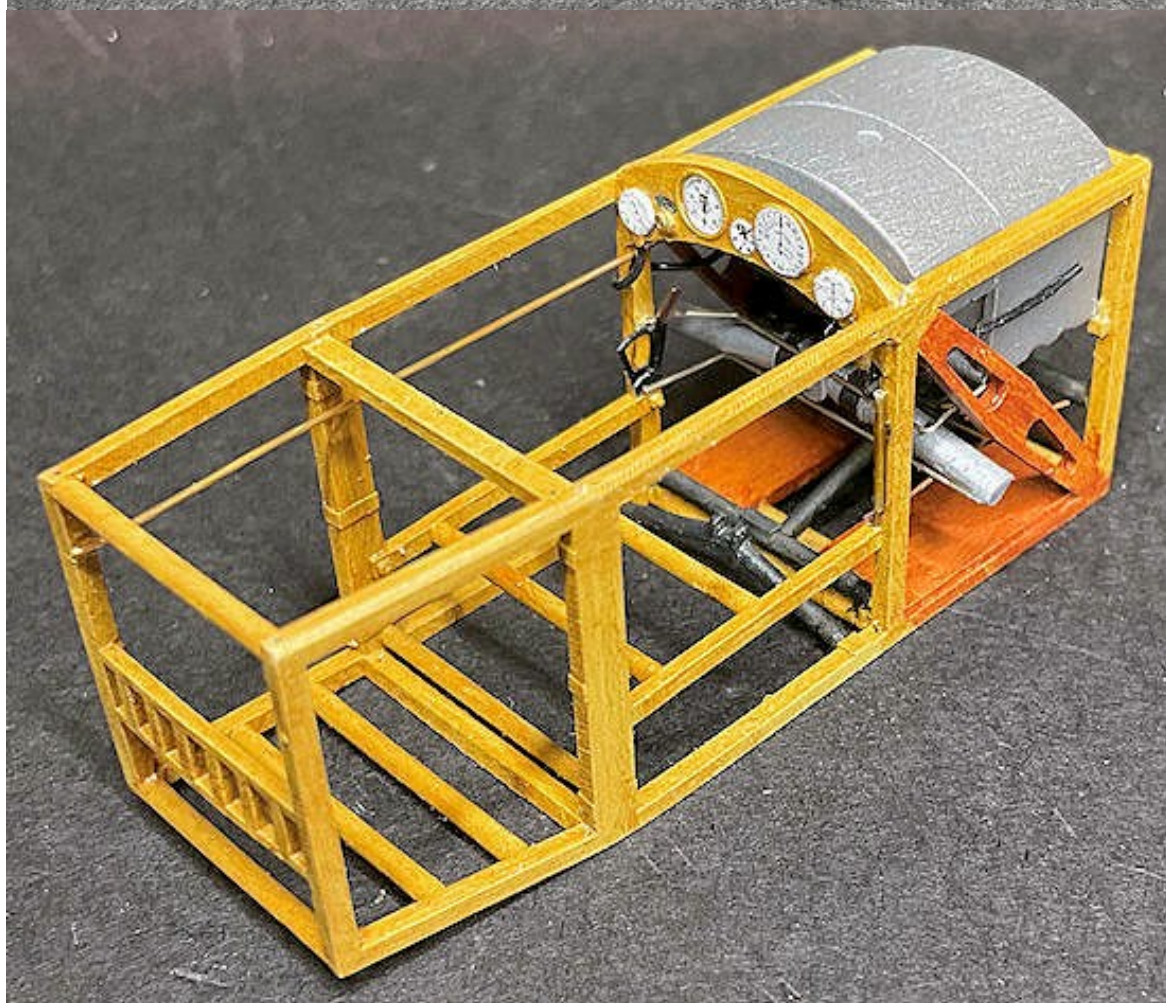
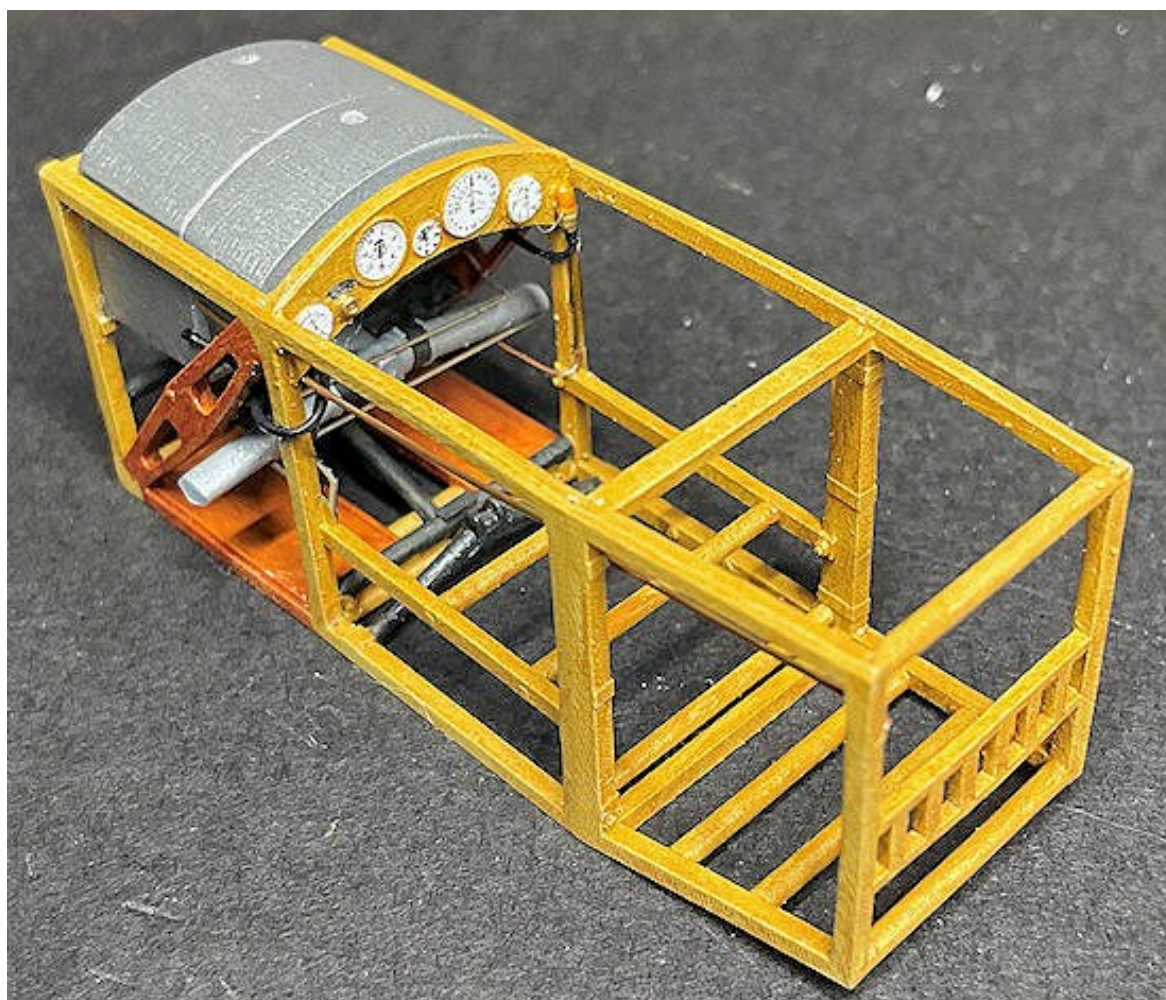

Rigging:

NOTE: *The holes for rigging the rudder bar and control column were drilled previously in this build log.*

Rudder bar:

Cut four long lengths of 0.12 mm diameter mono-filament, such as 'Steelon' or 'Stroft GTM'.

Cut four short lengths of 0.4 mm diameter Brass tube, such as 'Albion Alloy's' MBT04 or similar.

Pass a line through each of the pre-drilled holes through the rudder bar, leaving a short length protruding from one side of the rudder bar.

Secure the lines in the holes using thin CA adhesive.

Cut away the residual short lines from the side of the rudder bar.

Slide a cut tube onto each of the four lines and up to the rudder bar.

Secure the lines to the tubes using thin CA adhesive.

Control column:

Cut four long lengths of 0.12 mm diameter mono-filament, such as 'Steelon' or 'Stroft GTM'.

Cut four short lengths of 0.4 mm diameter Brass tube, such as 'Albion Alloy's' MBT04 or similar.

Pass a line through the pre-drilled hole across the base of the control column, leaving the same amount of line protruding from each side.

Secure the line in the hole using thin CA adhesive.

Slide a cut tube onto each side of the line and up to the control column.

Secure the line to the tubes using thin CA adhesive.

Pass a line through the two pre-drilled hole through the bottom of the control column, leaving a short length of line protruding from the forward side of the control column.

Secure the lines in the holes using thin CA adhesive.

Cut away the residual short lines from the forward side of the control column.

Slide a cut tube onto the two lines and up to the control column.

Secure the lines to the tubes using thin CA adhesive.

Modifications continued):

Gun trigger cable:

NOTE: *My assumption was that the pilots machine gun, being located on the top of the fuselage and in front of the windscreen, would be out of reach of the pilot and therefore was fired from inside the cockpit, probably from the trigger latch on the control column.*

Cut a long length of 0.3 mm diameter lead wire, such as that from 'PlusModel' or similar.

Secure the wire down the forward face of the control column, but not to the pilots hand grip, using thin CA adhesive.

Bend the wire at the bottom of the control column forwards.

Bend the top of the wire slightly forwards to represent the trigger latch.

Subsequently I noticed the gun firing button on the top of the pilots hand grip at the top of the control column. Therefore, the trigger bend at the top of the wire is not required.

Assembly (continued):

Locate the rudder bar between its locating 'peg' under the cockpit frame cross member and the top of the central bracing tube.

Secure the rudder bar in position using thin CA adhesive.

Locate the control column into its locating recess on the support tube (across the bottom of the cockpit).

Secure the control column in position using thin CA adhesive.

NOTE: Refer to page 3 of the kit instructions for placement of the photo-etch instrument bezels.

Brush a small amount of 'Tamiya' Clear Gloss (X22) over the faces of the three instrument.

Place the photo-etch bezels (2b, 4b and 5b) onto the instrument faces and gently press onto the clear gloss coat.

To seal the bezels onto the instruments, brush 'Tamiya' Clear Gloss (X22) over the faces of the three instruments.

To reveal the brass bezel around the remaining instrument, carefully scrape off the paint from the surrounding bezel, using a sharp and curved edge blade.

Rigging (continued):

Rudder control lines:

Pass the four rudder control lines rearwards and under the cross members of the cockpit frame to the bottom, rear cross member.

Keeping each line taut, secure them around the bottom, rear cross member using thin CA adhesive.

Cut away any residual line at the cross member.

Elevator control lines:

Pass the two elevator control lines (at the rear of the control column) rearwards. The upper line should be routed over the two seat support (across the cockpit frame). The lower line should be routed under the two seat support (across the cockpit frame).

Keeping the lower line taut, secure it around the bottom, rear cross member using thin CA adhesive.

Cut away any residual line at the cross member.

Pass the upper line through the central opening in the cockpit rear cross member.

Keeping the upper line taut, secure it around the bottom of the opening in the rear cross member using thin CA adhesive.

Cut away any residual line at the cross member.

Aileron control lines:

NOTE: The two aileron control lines will be final rigged when the cockpit is fitted inside the fuselage.

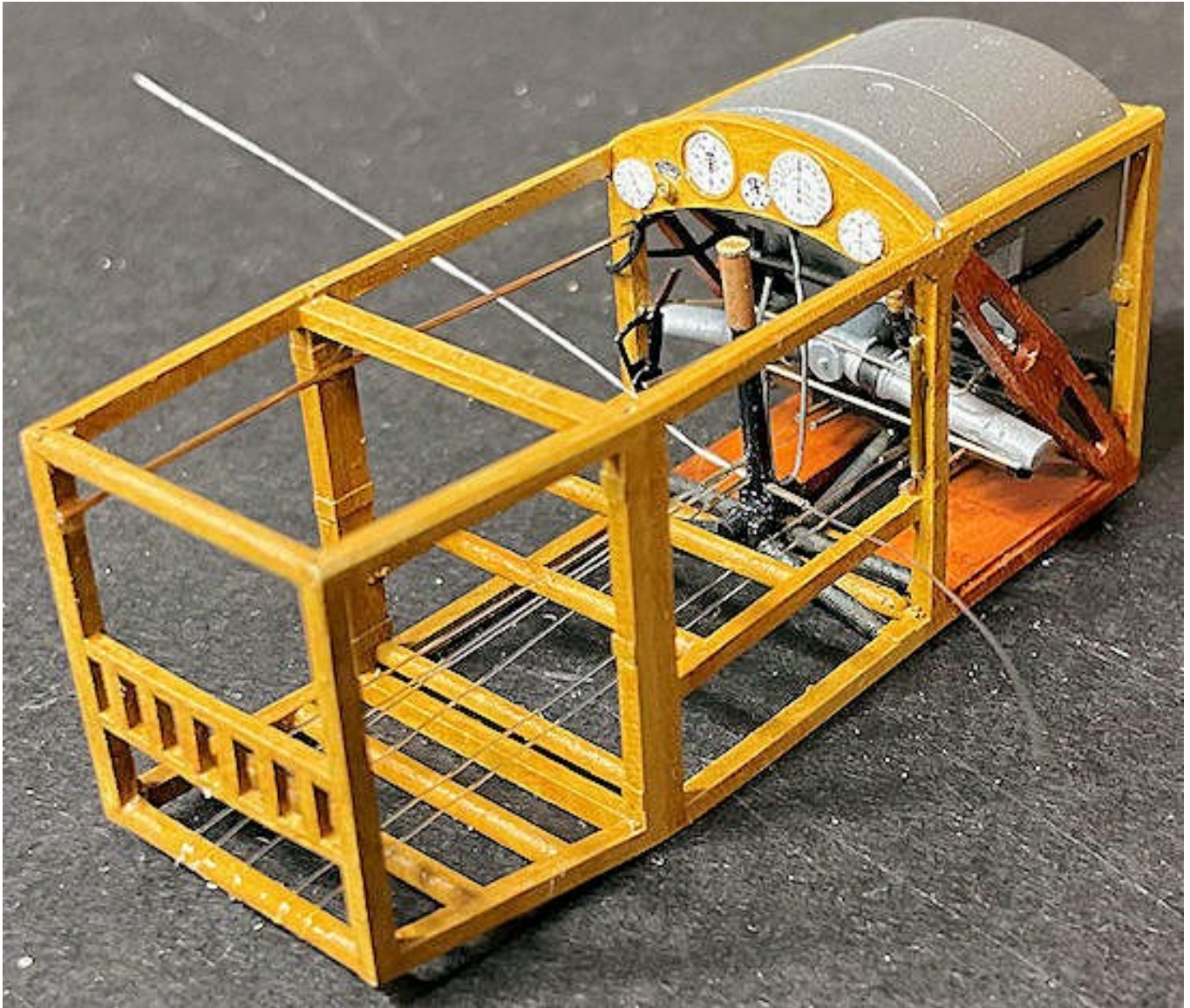

Cockpit side bracing wires:

NOTE: *The holes for rigging the bracing wires for the cockpit frame were drilled previously in this build log. Refer to the 'pre-rigging' section of this chapter for the drilled rigging holes.*

*The following procedure applies to **both sides** of the cockpit frame.*

As the cockpit opening of this aircraft is smaller than most, very little of the internal detail will be seen. Therefore, I chose to represent the turnbuckles with just tube.

Cut five long lengths of 0.12 mm diameter mono-filament, such as 'Steelon' or 'Stroft GTM'.

Cut five short lengths of 0.4 mm diameter Brass tube, such as 'Albion Alloy's' MBT04 or similar.

Pass a line through the pre-drilled holes in the bottom corners of the cockpit frame.

Slide a cut tube onto each of the five lines.

Keeping the tubes clear of the frame corners, secure the lines in the cockpit frame using thin CA adhesive.

Cut away any residual line at the underside of the cockpit frame.

Pass the free ends of the lines diagonally up and across and through the pre-drilled holes in the top corners of the cockpit frame.

Keeping the tubes clear of the frame corners, secure the lines in the cockpit frame using thin CA adhesive.

Cut away any residual line at the top of the cockpit frame.

Position each tube towards, but not at, the bottom of the fitted lines.

Secure the tubes to the lines using thin CA adhesive.

Cockpit frame bracing wires:

Repeat the previous procedure to add the two crossed bracing wires across the frame corners behind the pilots seat.

Cockpit floor bracing wires:

Cut four long lengths of 0.12 mm diameter mono-filament, such as 'Steelon' or 'Stroft GTM'.

Cut four short lengths of 0.4 mm diameter Brass tube, such as 'Albion Alloy's' MBT04 or similar.

Pass a line through the left and right side pre-drilled holes in the bottom corners of the cockpit frame (second bay).

Secure the lines in the holes using thin CA adhesive.

Cut away any residual end tag of line.

Slide a cut tube onto each of the lines.

Pass the free ends of the lines diagonally across the bottom of the bay (under the seat supports) and through the pre-drilled holes in the left and right corners at the rear of the bay.

Keeping the lines taut, secure the lines in the rear holes using thin CA adhesive.

Cut away any residual end tag of line.

Position each tube towards, but not at, the forward corners of the bay.

Secure the tubes to the lines using thin CA adhesive.

Repeat the procedure to add crossed lines to the rear bay of the cockpit frame, but position the tubes close to, but not touching, the rear corners.

Cut two long lengths of 0.12 mm diameter mono-filament, such as 'Steelon' or 'Stroft GTM'.

Using thin CA adhesive, secure one end of each line to the underside rear corners of the pilots foot boards.

Keeping the lines taut, diagonally cross the lines and using thin CA adhesive, secure the free ends of the lines to the opposite forward corners on the underside of the pilots foot boards.

Cut away any residual end tag of line.

Assembly (continued):

Using CA adhesive, secure the pilots seat centrally onto the two seat support (across the cockpit frame). Make sure the rear of the seat is slightly forward from the top, rear edge of the cockpit opening.

Pass the two aileron control lines outboard and between the seat support and bottom members of the cockpit side frames.

NOTE: *The pilots seat has to be fitted with its rear edge slightly forward from the cockpit rear padding, when fitted. The photo-etch seat belts supplied with the kit are not long enough to be fitted to the cockpit frame (as shown in the kit instructions) and reach over the pilots seat.*

Therefore I discarded the kit supplied seat belts and replaced them with '**HGW Models**' fabric belts from my 'spares'.

If used, the kit supplied belts can fitted, but further forward on the cockpit side frames.

Bend the photo-etch seat belts such that they realistically lay over the pilots seat.

Brush paint the seat belts with 'Tamiya' Buff (XF57) or similar.

Brush paint the metal fittings with 'Mr. Colour' Stainless Steel (213) or similar.

Secure the seat belts onto the cockpit side frames and the seat, using thin CA adhesive.



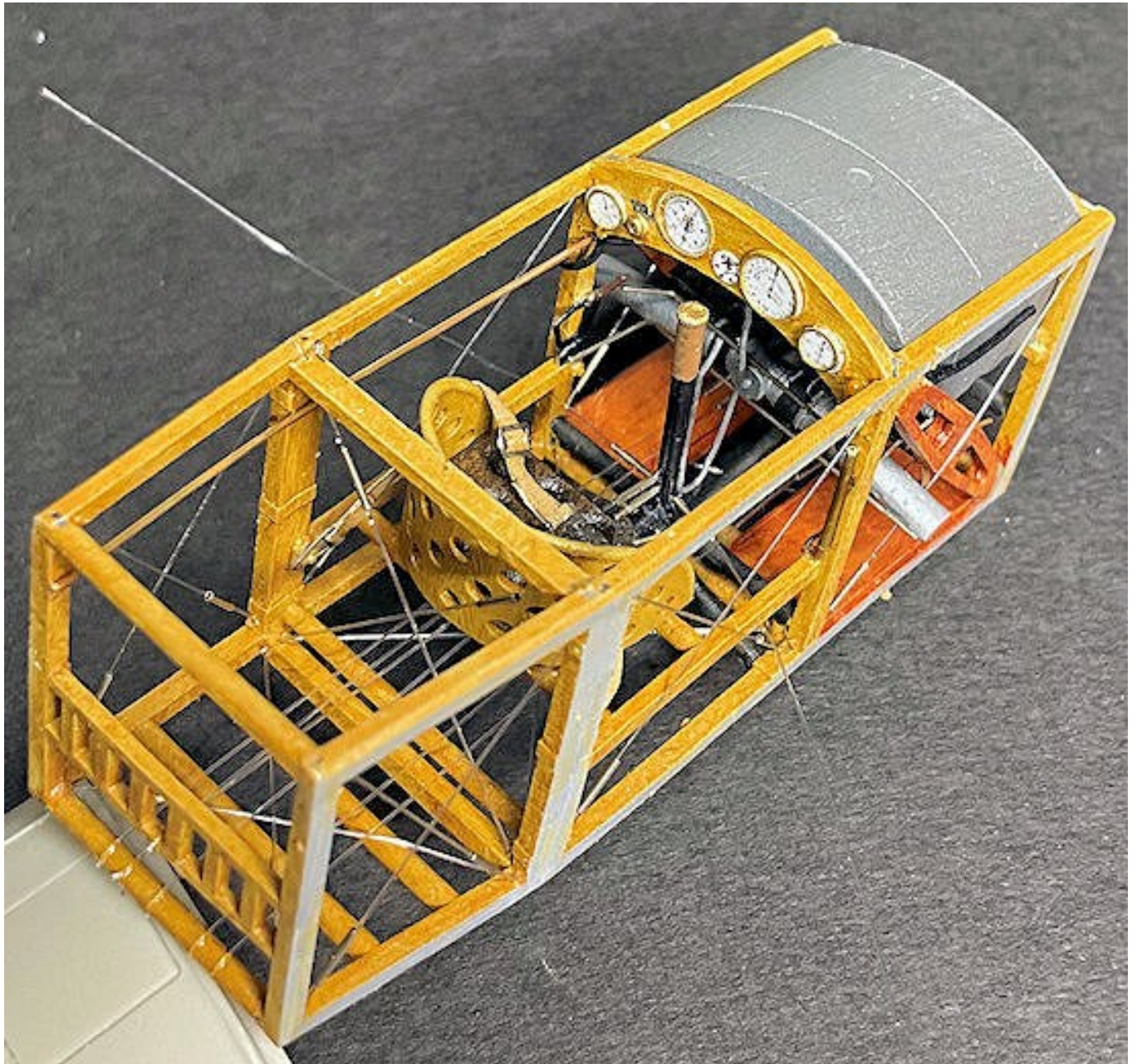

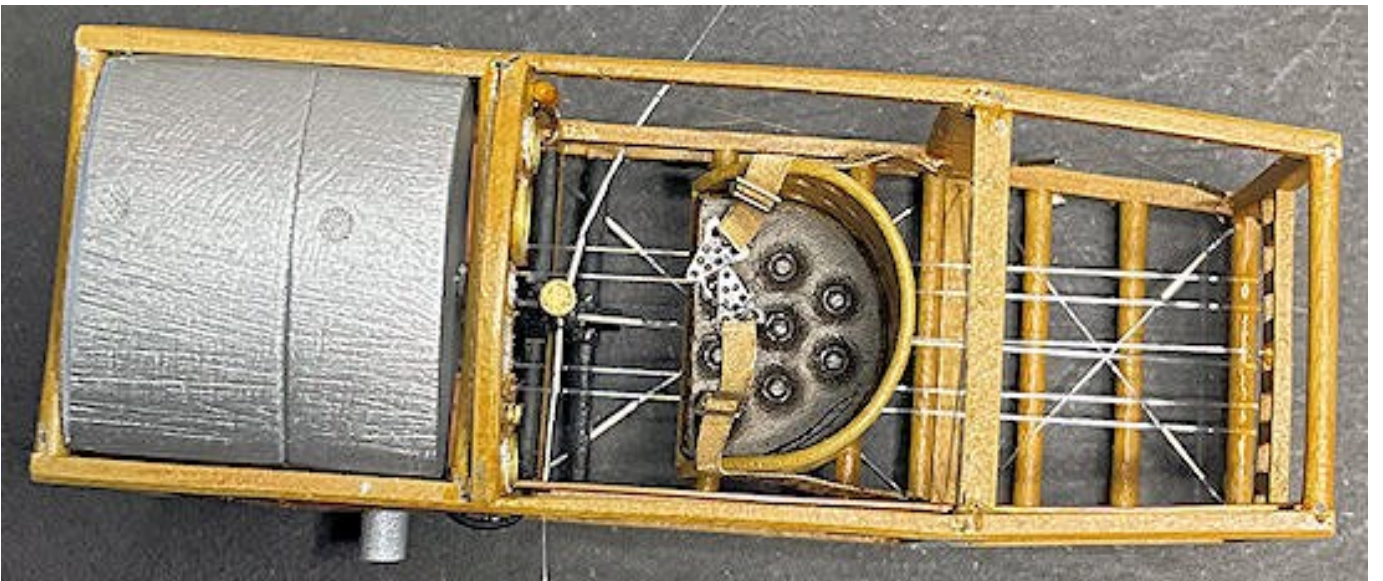
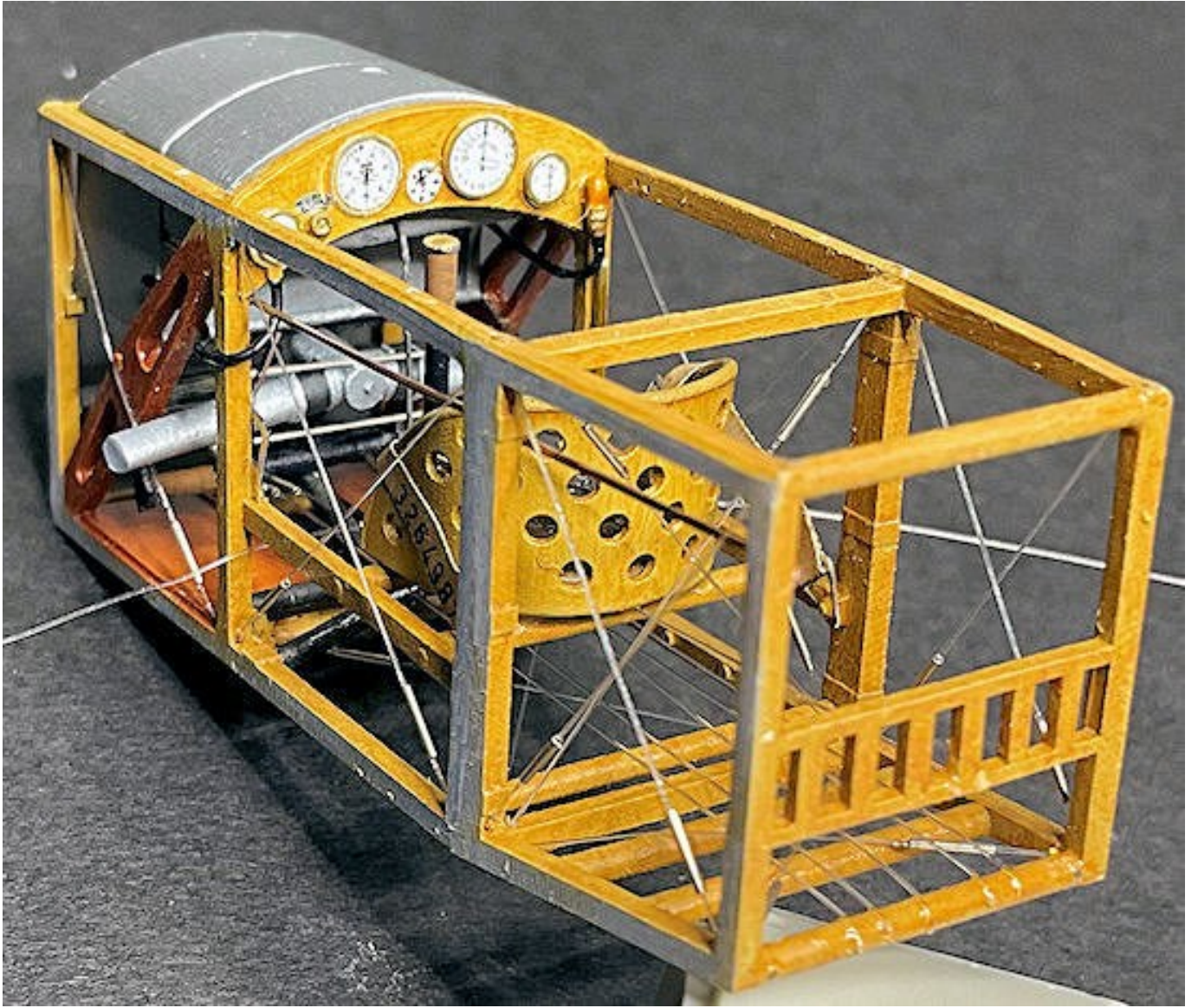

Weathering:

NOTE: *Refer to Part 2 (Weathering) of this build log.*

Lightly airbrush a semi-matte clear coat, such as 'Alclad' Light Sheen (ALC-311) or similar, over the inner sides of the fuselage. This will provide a good base for applying weathering.

Apply weathering, as desired, to the inner sides of the fuselage. I used 'Flory Models' Dark Dirt fine clay wash.

Once the desired effect is achieved, lightly airbrush coat of a semi-matte clear coat, such as 'Alclad' Light Sheen (ALC-311) or similar, over the inner sides of the fuselage. This will seal the applied weathering.

Assembly (continued):

Check fit the cockpit assembly into the fuselage halves, making sure the two halves join fully together.

Pass the left aileron cable from the cockpit assembly through the pre-drilled hole in the wing root area of the left fuselage half.

Pull the line from the outside whilst locating the cockpit assembly fully into the left fuselage half.

Pass the right aileron cable from the cockpit assembly through the pre-drilled hole in the wing root area of the right fuselage half.

Draw the two fuselage halves close together.

Apply thin CA adhesive along the top and front mating surfaces of the left fuselage half.

Join the two fuselage halves fully together.

Apply thin CA adhesive along the bottom and rear fuselage joints.

If necessary, apply extra thin CA adhesive along any gaps along the fuselage joints.

Pulling the two aileron control lines taut, secure them in the pre-drilled holes using thin CA adhesive.

Cut away any residual line at the outside wing roots.

NOTE: *'Araldite' 2 part epoxy resin adhesive is used to secure the cockpit rear padding, as it allows time to position the padding in the fuselage.*

Mix a small amount of 'Araldite' 2 part epoxy resin (50/50) adhesive.

Apply the adhesive to the face of the fuselage headrest.

Insert the cockpit rear padding into the fuselage and fully locate it onto the applied adhesive on the fuselage headrest.

Leave the adhesive to fully set.

Sand or scrape any residual CA adhesive from along the fuselage joint seams, to blend the surfaces together.

NOTE: *In the following steps, drilling out the locating recesses in the fuselage panel for the three filler caps and the two carburettor air intakes allowed the parts to fit more easily.*

Refer to page 5 of the kit instructions and using thin CA adhesive, secure the three filler caps into their recesses in the fuselage decking panel.

Refer to page 5 of the kit instructions and using thin CA adhesive, secure the two carburettor air intakes into their recesses in the fuselage sides.



PART 11

CONSTRUCTION

PART 11 - CONSTRUCTION

References:

Windsock Date file No.12 - Hanriot HD.1 (by J.M Bruce).

NOTE: *As this model is resin, all assembly of parts must be done using CA adhesive. The resin used to 3D print some of the parts is brittle. Therefore, care is needed when removing the parts from their print supports and when subsequently when handling.*

Preparation:

NOTE: *The resin cast parts may have molding 'flash', rough or badly fitting joints and seams, surface artifacts, such as surface blemishes and air 'blow' holes. All of these will need to be rectified before any assembly is attempted.*

The resin 3D printed parts, once removed from the print supports, will need to have residual support tags removed.

Photo-etch parts, once removed from their sheet, should have residual tags removed.

Refer to pages 5 to 9 of the kit instructions for the parts required.

Remove the required 3D printed parts required from their print supports.

Remove the required photo-etch parts required from the kit supplied sheet.

NOTE: *All of the resin cast flight surfaces (wings, tail plane, elevator, ailerons, fin and rudder) have heavy and pronounced ribs tapes, which will need to be reduced. These rib tapes have caused rippling along the wing leading edges, which also needs to be removed. Lastly, the internal metal reinforcing rods keeping the resin wings from distorting, are very close to the surface and their ends have broken through the wing tips. This will require filling and sanding.*

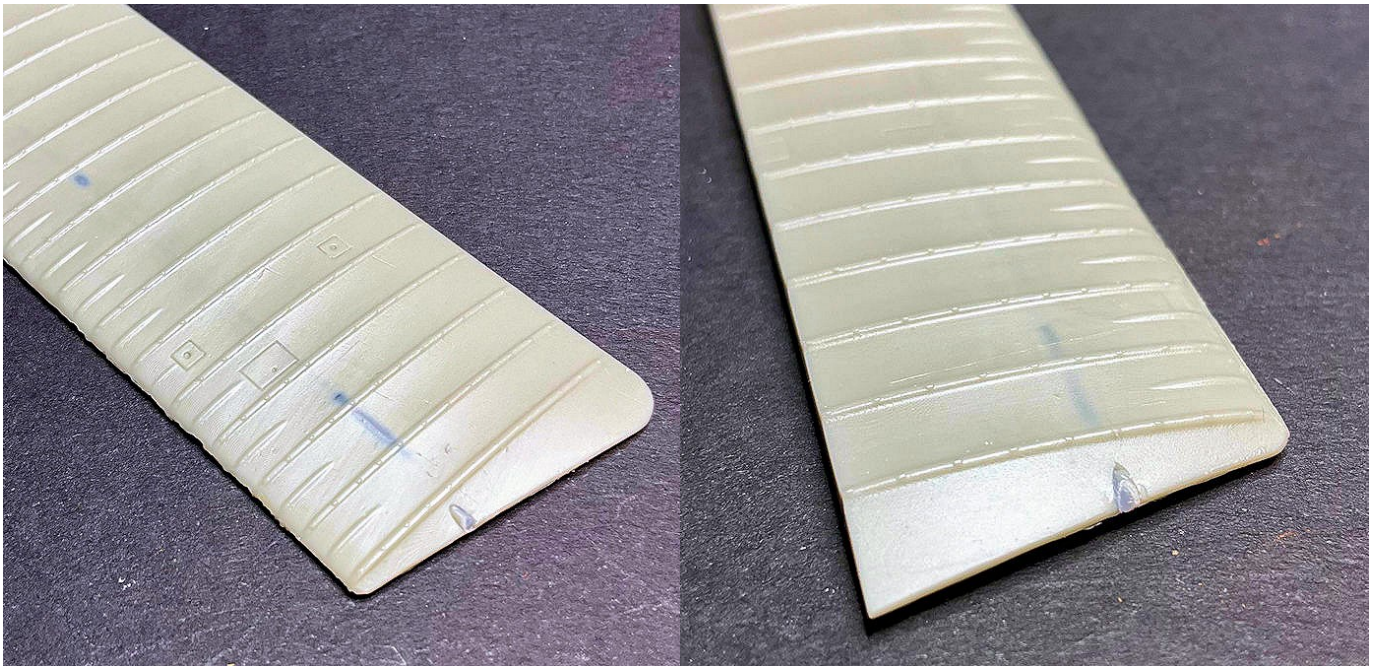

Sand down or scrape off the rib tapes on both sides of the upper and lower wing halves, both ailerons, tailplane, elevator, rudder and the fin, leaving the rib tape witness marks:

Fill any air 'blow holes' in any of the surfaces

Fill any larger surface irregularities, such as resin delamination's or support rod 'break through with such as 'Mr. Hobby' dissolved putty or similar.

Once the filler used has fully set, sand the areas to blend them with the surrounding area.

Tailplane:

NOTE: *The rear, top of the fuselage has two 1.2 mm diameter holes, which are intended to be used to locate the tailplane. The tailplane has two recesses that are to be drilled through for locating rods into the fuselage. However the fuselage holes are far too large for locating rods.*

Cut two lengths of 0.5 mm diameter Brass rod, such as that from 'Albion Alloy's' or similar.

Cut two lengths of 1.2 mm diameter Brass tube, such as 'Albion Alloy's' MBT12 or similar.

Secure the rods fully into the tubes, using thin CA adhesive.

File the flush ends of the tube/rods such that they can be inserted into the fuselage holes and in contact with the bottom, inside of the fuselage with the tube tops flush with the top of the fuselage.

Secure the tubes fully into their fuselage holes using thin CA adhesive, making sure the protruding rods are vertical on the fuselage when viewed from the sides and rear.

Using the pre-molded recess in the tailplane as guides, drill through the tailplane using a 0.5 mm diameter drill.

NOTE: *The underside of the tailplane has the pre-molded recesses for attaching the tailplane support struts.*

Locate the tailplane onto the rods, making sure the tailplane is fully in contact with the fuselage and at 90 degrees to the fuselage, when viewed from above and horizontal to the fuselage when viewed from the front or rear.



Fin:

Position the fin on the top of the tailplane with its front edge aligned to the leading edge of the tailplane.

Mark the bottom edge of the fin with the position of the two protruding rods from the tailplane.

Using the marks as guides, point mark their locations into the centre of the bottom face of the fin.

Using the point marks as guides, drill holes of 0.5 mm diameter up into the fin, keeping the drill vertical.

Trim the height of the fuselage rods such that the fin can be fully located onto the top of the tailplane.

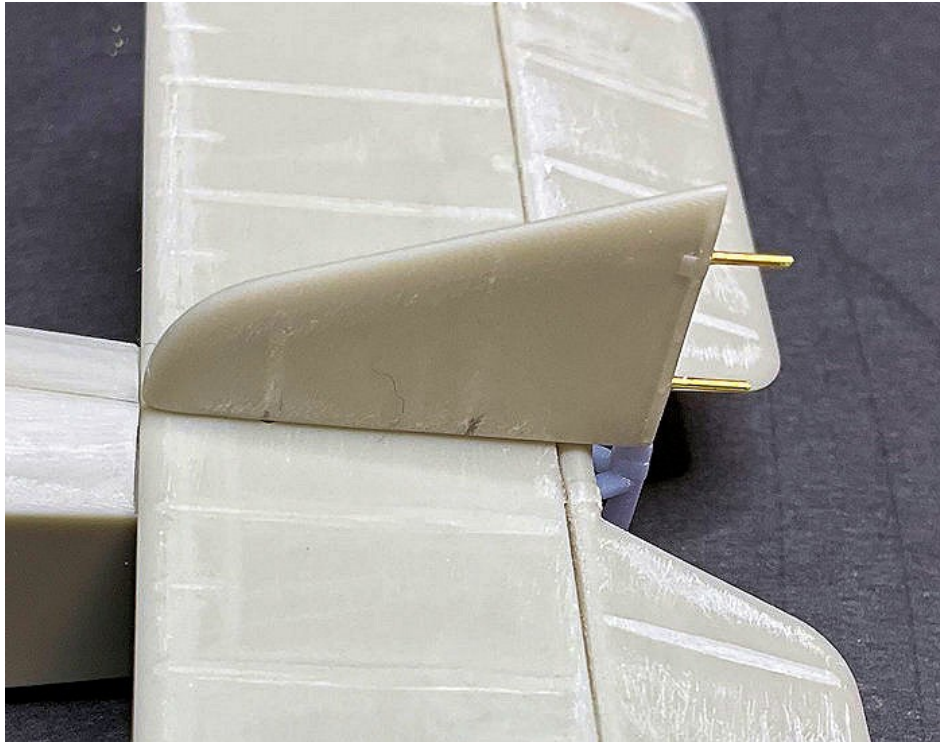

Rudder:

Position the rudder against the rear edge of the fin with their top edges aligned.

Using the top hinges on the fin and rudder as guides, point mark the centre of the fin rear face and the rudder leading edge.

Using the point marks as guides, drill holes of 0.5 mm diameter horizontally into the fin and rudder.

Cut two lengths of 0.5 mm diameter Brass rod, such as that from 'Albion Alloy's' or similar.

Secure a rod fully into the fin, using thin CA adhesive.

Trim the length of the rod such that the rudder can be fully located against the fin.

Mark the side of the fin and rudder further down and at the same distance from the bottom of the fin as the fitted rod is from the top of the fin.

Using the point marks as guides, drill holes of 0.5 mm diameter horizontally into the fin and rudder.

Secure the second rod fully into the fin, using thin CA adhesive.

Check that the rudder can be fully located on the fin rods and is against the trailing edge of the fin.

Elevator:

Cut six lengths of 0.5 mm diameter Brass rod, such as that from 'Albion Alloy's' or similar

Using the six hinges on the tailplane trailing edge as guides, point mark the centre of the tailplane trailing edge.

Using the point marks as guides, drill holes of 0.5 mm diameter horizontally into the tailplane trailing edge.

Secure the six rods fully into the holes in the tailplane, using thin CA adhesive.

Position the elevator against the trailing edge of the tailplane with its outer tips aligned to those of the tailplane.

Mark the leading edge of the elevator with the position of the six protruding rods from the tailplane.

Using the marks as guides, point mark their locations into the centre of the elevator leading edge.

Using the point marks as guides, drill holes of 0.5 mm diameter horizontally into the elevator leading edge, keeping the drill at 90 degrees to the leading edge when viewed from above.

Trim the length of the tailplane rods such that the elevator can be fully located onto the tailplane.

Carefully bend the elevator on its rods to be angled slightly downwards.



Ailerons:

NOTE: *The following procedure applies to both ailerons.*

Cut four lengths of 0.5 mm diameter Brass rod, such as that from 'Albion Alloy's' or similar

File or sand away the four protruding hinges on the leading edge of the aileron.

Point mark the centre of the four aileron hinge locating recesses in the trailing edge of the upper wing.

Using the point marks as guides, drill holes of 0.5 mm diameter horizontally into the trailing edge of the upper wing, keeping the drill at 90 degrees to the trailing edge when viewed from above.

Secure the four rods fully into the holes in the trailing edge of the wing, using thin CA adhesive.

Position the aileron against the trailing edge of the wing.

Mark the leading edge of the aileron with the position of the four protruding rods from the wing.

Using the marks as guides, point mark their locations into the centre of the aileron leading edge.

Using the point marks as guides, drill holes of 0.5 mm diameter horizontally into the aileron leading edge, keeping the drill at 90 degrees to the leading edge when viewed from above.

Trim the length of the wing rods such that the aileron can be fully located onto the wing.

NOTE: *If the ailerons are to be positioned opposed, the left and right ailerons should be angled in opposite directions.*

Carefully bend the one aileron on its rods to be angled slightly downwards and the other aileron the same amount but upwards.

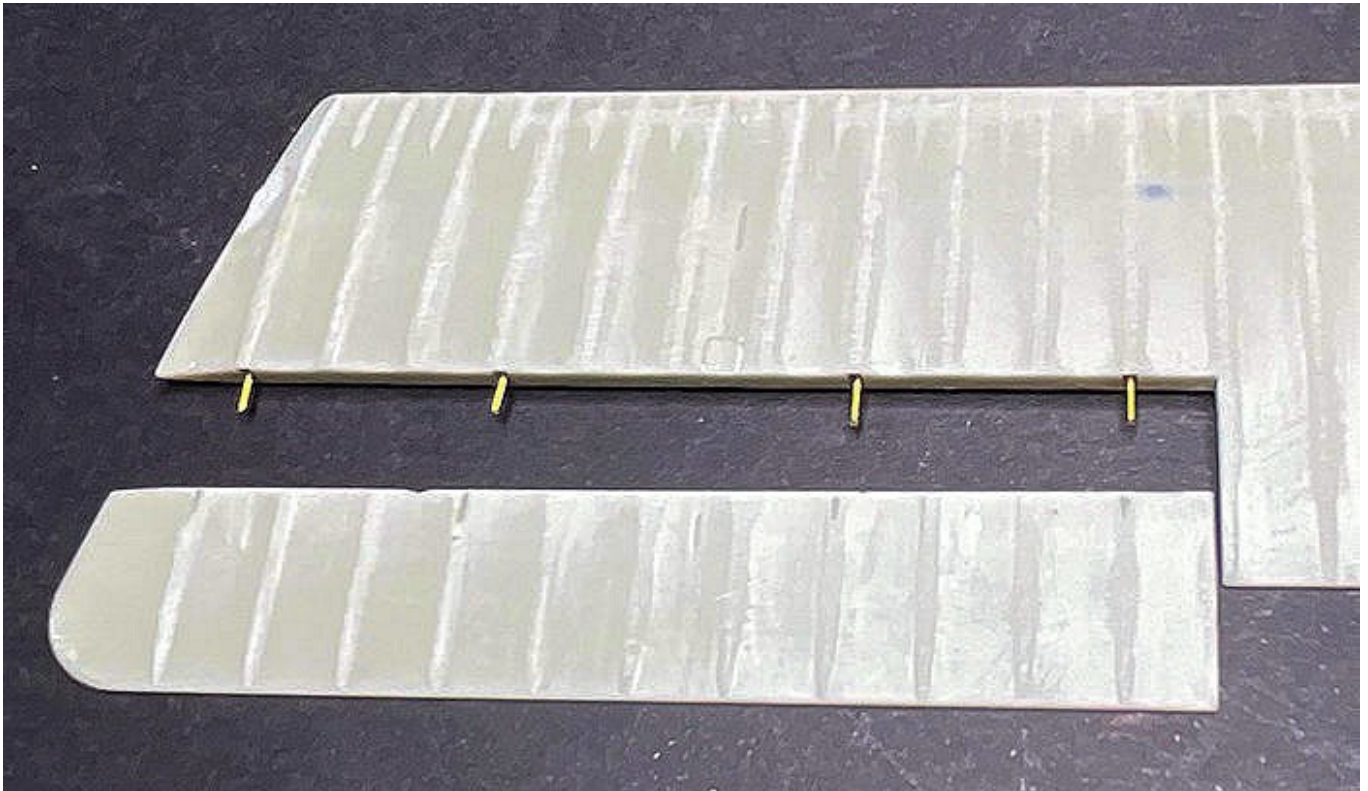

Lower wings to fuselage:

NOTE: *There are pre-molded recesses in the wings and fuselage for drilling holes for the attachment rods. When drilling into the fuselage, take care to not damage the internal cockpit frame and components/rigging.*

Using the pre-molded recesses in the wing roots in the fuselage, drill a hole of 1.0 mm diameter into the front recess and 0.8 mm diameter into the rear recess. Make sure the holes are drilled horizontally when viewed from the front and 90 degrees to the fuselage when viewed from above.

Using the pre-molded recesses in the wing roots, drill a hole of 1.0 mm diameter into the front recess and 0.8 mm diameter into the rear recess. Make sure the holes are drilled horizontally when viewed from the front and 90 degrees to the fuselage when viewed from above.

Cut two lengths of 1.0 mm diameter Brass rod, such as that from 'Albion Alloy's' or similar.

Cut two lengths of 0.8 mm diameter Brass rod, such as that from 'Albion Alloy's' or similar.

Secure the 1.0 mm diameter rods fully into the front holes in the wing roots and the 0.8 mm diameter rods into the rear holes.

Trim the length of the rods such that the lower wings can be fully located onto the fuselage. When located both wings should be horizontal and 90 degrees to the fuselage.

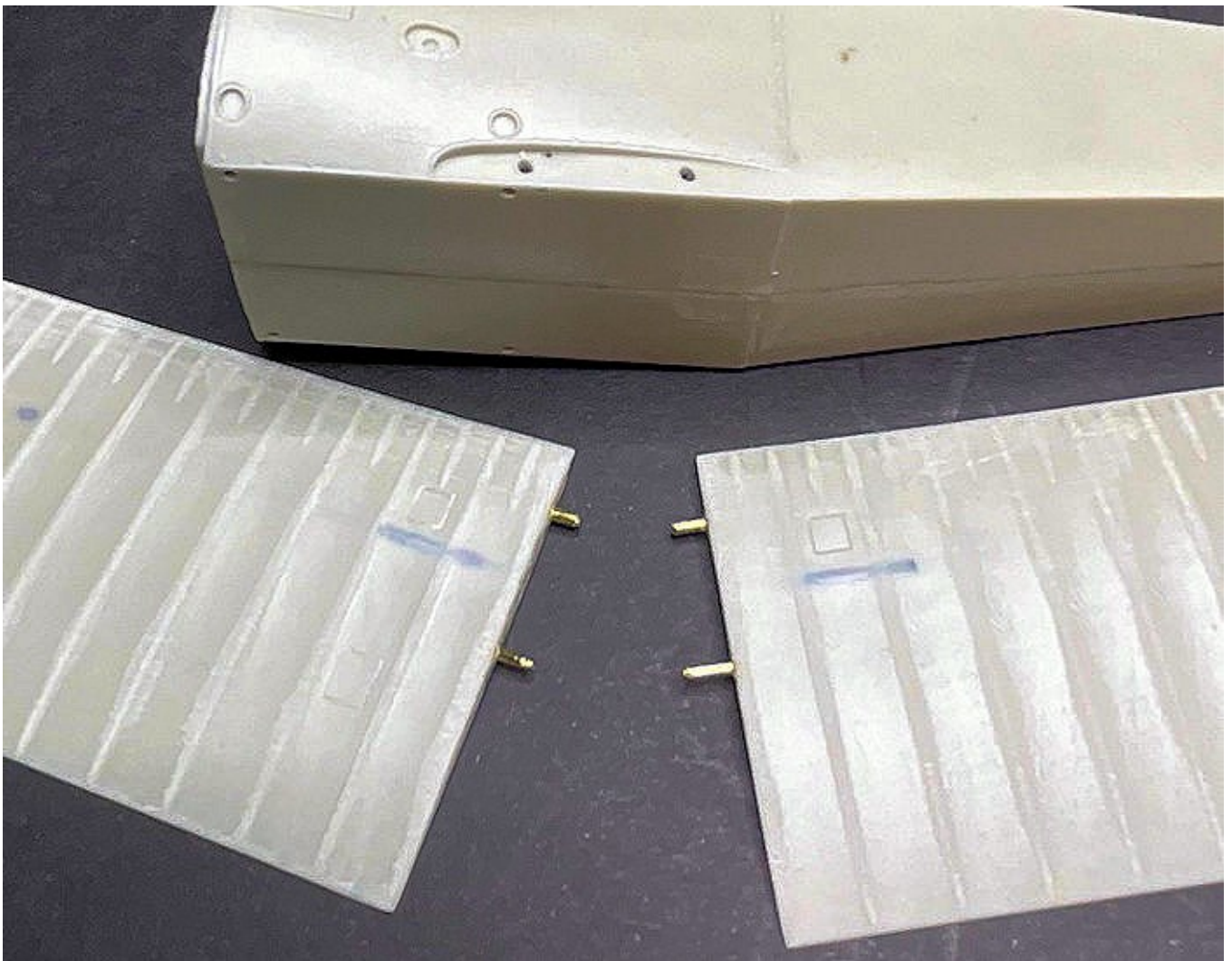

Upper wings to each other:

NOTE: *The upper wing halves are intended to be joined together using inserted rods, which pass through holes in the top of the 3D printed cabane struts assembly. However, the spread of the printed cabane struts is too wide to fit into the fuselage recesses and pressure needs to be applied to get the struts located. Also, ends of the struts are not shaped to fit into their locating recesses in the fuselage.*

*Do not apply **too much pressure** to the 3D printed cabane struts as they may break. The resin used is brittle and the struts do not have internal reinforcing rods fitted.*

Carefully file or sand the ends of the cabane struts to allow them to fit into their respective locating recesses in the fuselage decking panel.

One by one, hold each cabane strut in its locating recess in the fuselage decking panel and drill a hole of 0.5 mm diameter through the strut and fuselage,

Cut four lengths of 0.5 mm diameter Brass rod, such as that from 'Albion alloy's' or similar.

Temporarily locate the cabane struts into their locating recesses and pass the cut rods through the struts and into the fuselage.

Check that the cabane struts are fully located and are not bowed when viewed from the sides and front.

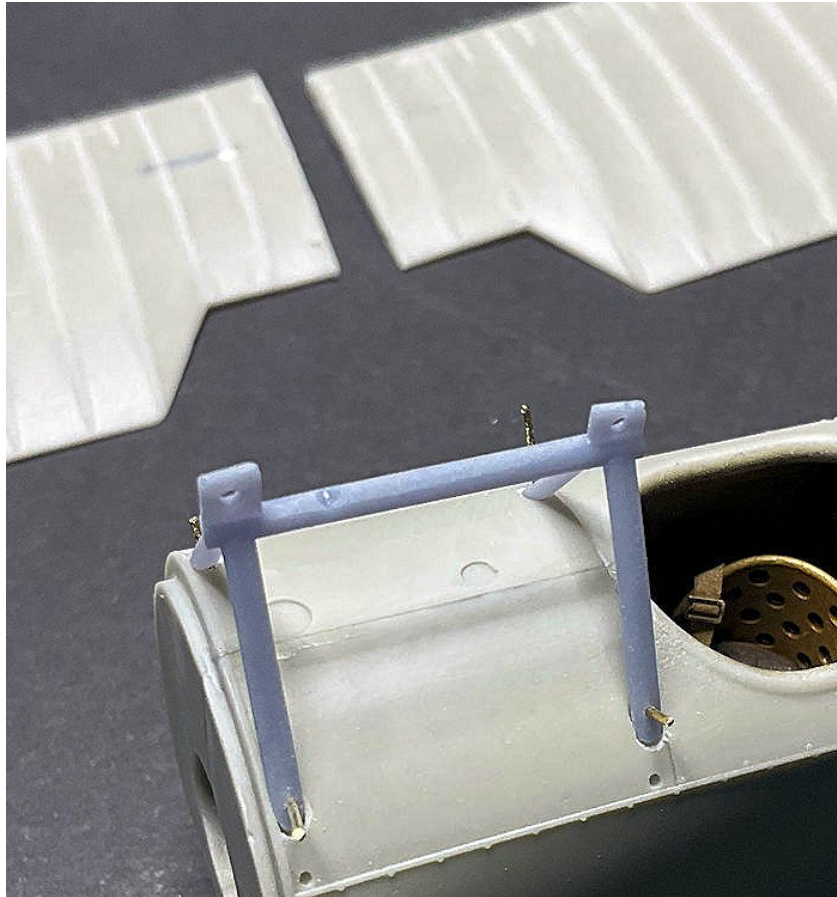

NOTE: *Smaller rear locating holes in the wing halves are necessary to prevent the drilled holes breaking through the wings.*

Using the pre-molded location recesses in the wing roots, drill a hole of 1.0 mm diameter into the front recess and 0.8 mm diameter into the rear recess of both wing halves. Make sure the holes are drilled horizontally when viewed from the front and 90 degrees to the fuselage when viewed from above.

Cut a length of 1.0 mm diameter Brass rod, such as that from 'Albion Alloy's' or similar.

Cut a length of 0.7 mm diameter Brass tube, such as 'Albion Alloy's' MBT07 or similar.

Using thin CA adhesive, secure the 1.0 mm diameter rod fully into the front hole of one wing and the 0.7 mm tube in the rear hole of the wing.

Test fit the rods through the holes at the top of the cabane struts then into the drilled holes in the opposite wing half.

Trim the length of the rods such that the both wing halves can be fully located into each other and the cabane strut tops.

Remove the wing halves and cabane struts for fitting later in the build.

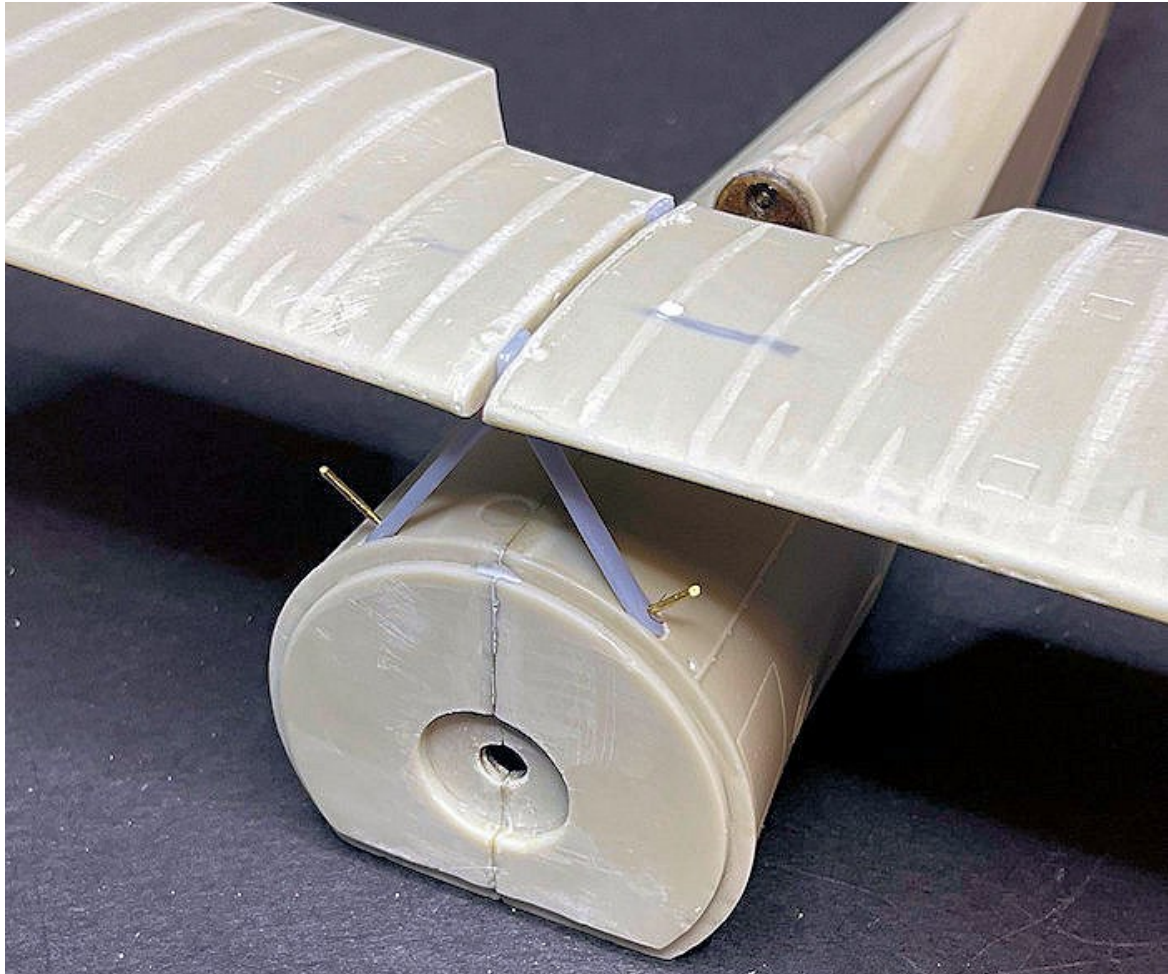

Inner wing support struts:

NOTE: Four 3D printed support struts are fitted between the bottom edge of the fuselage decking panel and the underside of the upper wing.

Cut eight lengths of 0.3 mm diameter Brass rod, such as that from 'Albion alloy's' or similar.

Drill holes of 0.3 mm diameter through the top mounting lugs of the four support struts, keeping the drill at 90 degrees to the flat side of the mounting lugs.

Drill holes of 0.3 mm diameter into the end of the four struts.

Using thin CA adhesive, secure the cut rods into the pre-drilled holes in the struts, keeping the rods in the mounting lugs flush with the outside of the lugs.

Using the pre-molded recesses in the bottom edges of the fuselage decking panel as guides, drill holes of 0.3 mm diameter through the fuselage.

NOTE: The strut locating holes in the underside of the upper wing will be drilled later in the build.



Tailplane support struts:

NOTE: Two 3D printed support struts are fitted between the bottom, rear edge of the fuselage and the underside of the tailplane. The correct struts are the shorter of the two pairs supplied in the kit.

Cut four lengths of 0.3 mm diameter Brass rod, such as that from 'Albion alloy's' or similar.

Drill holes of 0.3 mm diameter through top angled ends of the two support struts, keeping the drill at 90 degrees to the flat side.

Drill holes of 0.3 mm diameter into the end of the two struts.

Using thin CA adhesive, secure the cut rods into the pre-drilled holes in the struts, keeping the rods in the angled ends flush with the outside of the struts.

Using the pre-molded recesses (forward recesses) in the in the bottom, rear edge of the fuselage as guides, drill holes of 0.3 mm diameter through the fuselage.

NOTE: The strut locating holes in the underside of the tailplane will be drilled later in the build.



Landing gear struts:

NOTE: The struts on the 3D printed landing gear have recesses in the top of the struts and similar on the underside if the fuselage. These are intended to be drilled into to allow the fitting of locating rods.

Use, as guides, the recesses in the top of the landing gear struts and drill holes of 0.8 mm diameter centrally into the struts, making sure the drill is kept aligned to the strut (to avoid drill 'break through' the side of the strut).

NOTE: *During the following step, take care to avoid drilling through the fuselage and into the cockpit details.*

Use, as guides, the recesses in the forward, underside of the fuselage and drill holes of 0.8 mm diameter into the fuselage, making sure the drill is angled to the same as the landing gear struts (when fitted).

Cut four lengths of 0.8 mm diameter Brass rod, such as that from 'Albion Alloy's' or similar.

Using thin CA adhesive, secure the rods into the holes in the ends of the struts.

Test fit the landing gear into the holes drilled into the fuselage and if necessary, trim the length of the exposed rods to allow the struts to fully insert into the fuselage.

NOTE: *The kit supplied 3D printed wheels are intend to be butt joined onto the ends of the landing gear axle. However. This may be a weak joint, so reinforcing the joint with rods is advised.*

Centre point mark the ends of the landing gear axle and the locating recesses in the wheels.

Using the point marks as guides, drill holes of 1.0 mm diameter into the ends of the landing gear struts.

Using the point marks as guides, drill holes of 1.0 mm diameter through the wheels.

Cut two lengths of 1.0 mm diameter Brass rod, such as that from 'Albion Alloy's' or similar.

Using thin CA adhesive, secure the rods into the holes in the ends of the landing gear axle.

Test fit the wheels onto the axle rods and if necessary, trim the length of the exposed rods to allow the wheels to fully locate onto the axle and be flush with the outer centre hub.

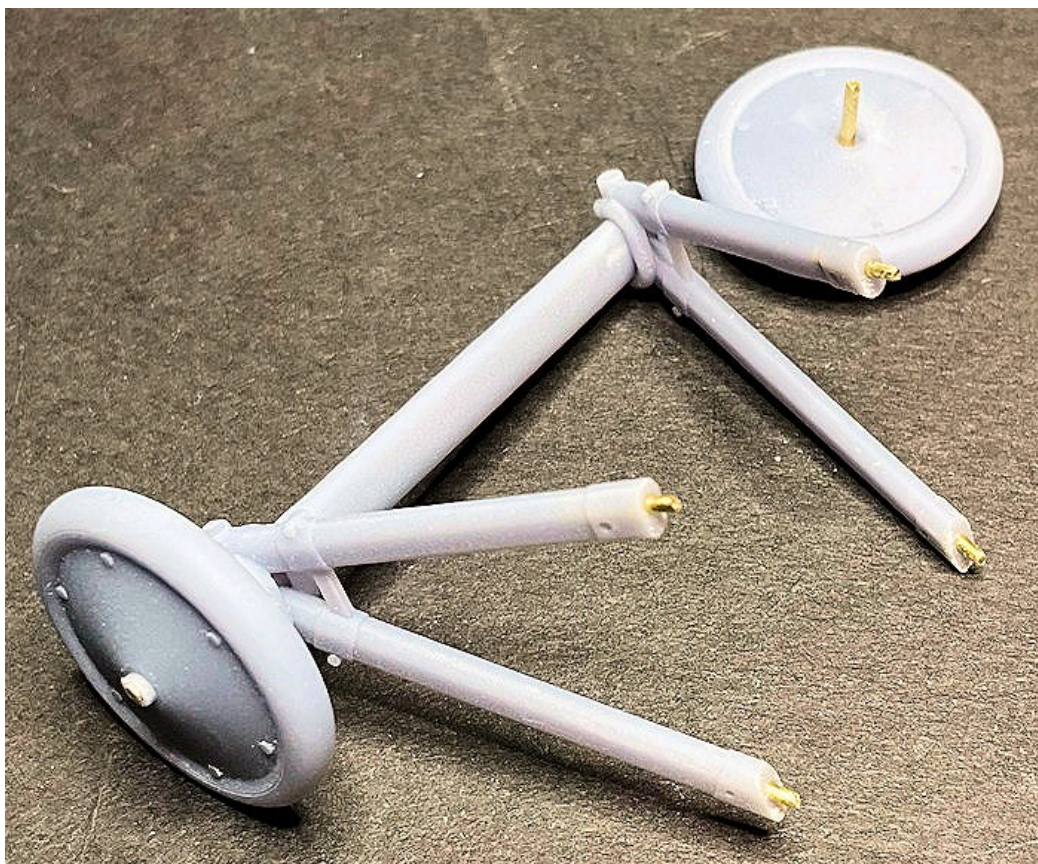

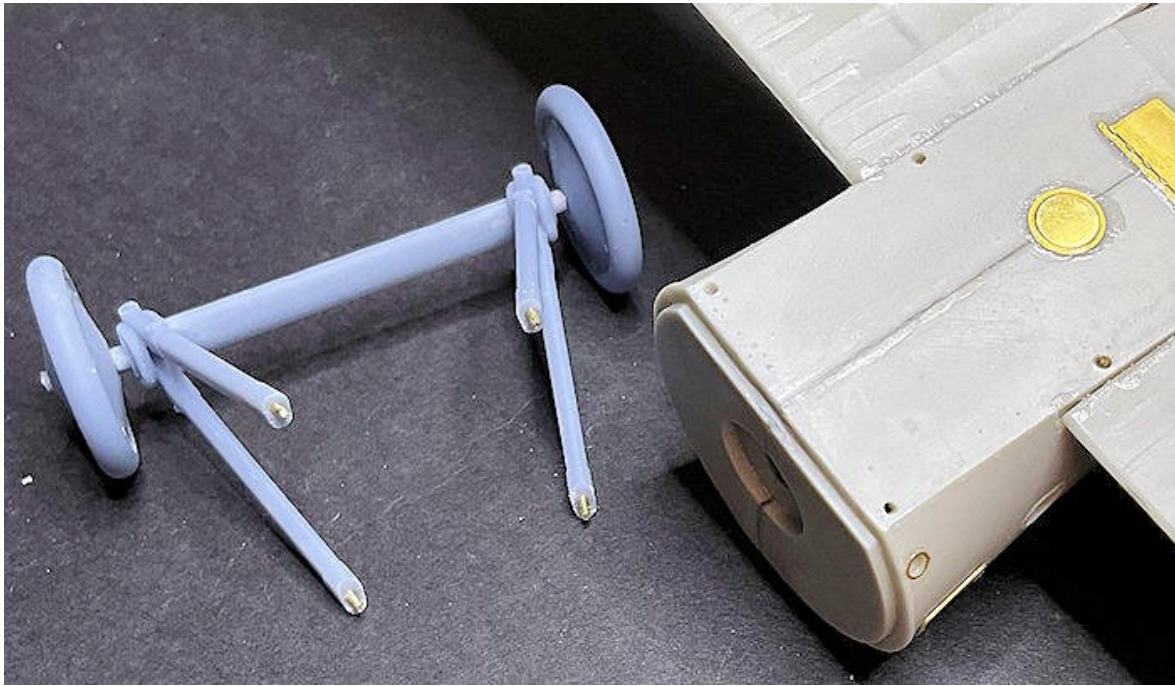

Tail skid:

Using thin CA adhesive, secure the 3D printed tail skid support to the rear of the fuselage.

NOTE: *The 3D printed tail skid is too thick and needs to be reduced.*

File or sand the sides of the 3D printed tail skid to reduce it to a more 'in-scale' thickness.

NOTE: *The 3D printed tail skid is intended to be 'butt' joined to the support frame. This will be a weak joint and needs to be reinforced.*

Drill a hole of 0.5 mm diameter centrally up into the bottom of the rudder post at the rear of the tail skid support.

Drill a hole of 0.5 mm diameter through the tail skid pivot block and at the angle that when fitted with a Brass rod, will allow the top of the tail skid to rest on the fuselage underside.

Cut a length of 0.5 mm diameter Brass rod, such as that from 'Albion Alloy's' or similar.

Secure the rod fully into the hole drilled in the tail skid.

Trim the length of the rod to allow the tail skid to be located into the hole drilled in the rudder post, making sure the top of the tail skid contacts the fuselage underside.

Remove the tail skid for fitting later in the build log.

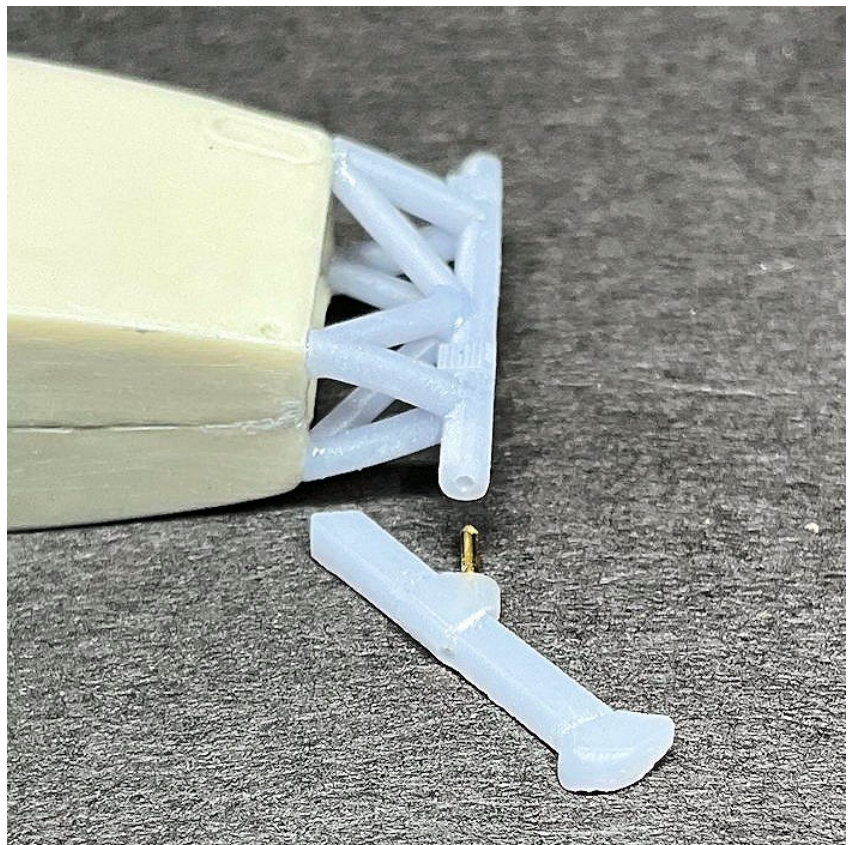

Photo-etch parts:

NOTE: *Not all of the kit supplied photo-etch parts are required for this model, as some are intended for other versions. Some parts in the kit instructions are too small and not really necessary, so were not used. Refer to pages 5, 6, 7 and 8 for placement of parts.*

Although the rigging tabs on the parts 25 and 26 would probably be strong enough for stretch line, such as 'EZ, it is not strong enough for tensioned mono-filament rigging. Therefore, I chose to cut away the rigging tabs before fitting the parts.

Using thin CA adhesive, secure the following photo-etch parts to the fuselage:

11 (x 2), 12 (x 2), 13, 14, 15, 16 (x 2) and 17 (x 4).

Using thin CA adhesive, secure the following photo-etch parts to the upper wing halves:

19 (x2), 21 (x 8), 25 (x 4), 26 (x 4) and 27 (x 2).

Using thin CA adhesive, secure the following photo-etch parts to the lower wing halves:

19 (x 2), 20, 21 (x 4), 22 (x 2) and 24 (x 4).

Using thin CA adhesive, secure part 33 to the trailing edge of the rudder. Secure one side then bend around the rudder to secure the opposite side.

Using thin CA adhesive, secure part 30 (x 2) to the ailerons. Secure one side then bend around the ailerons to secure the opposite side.

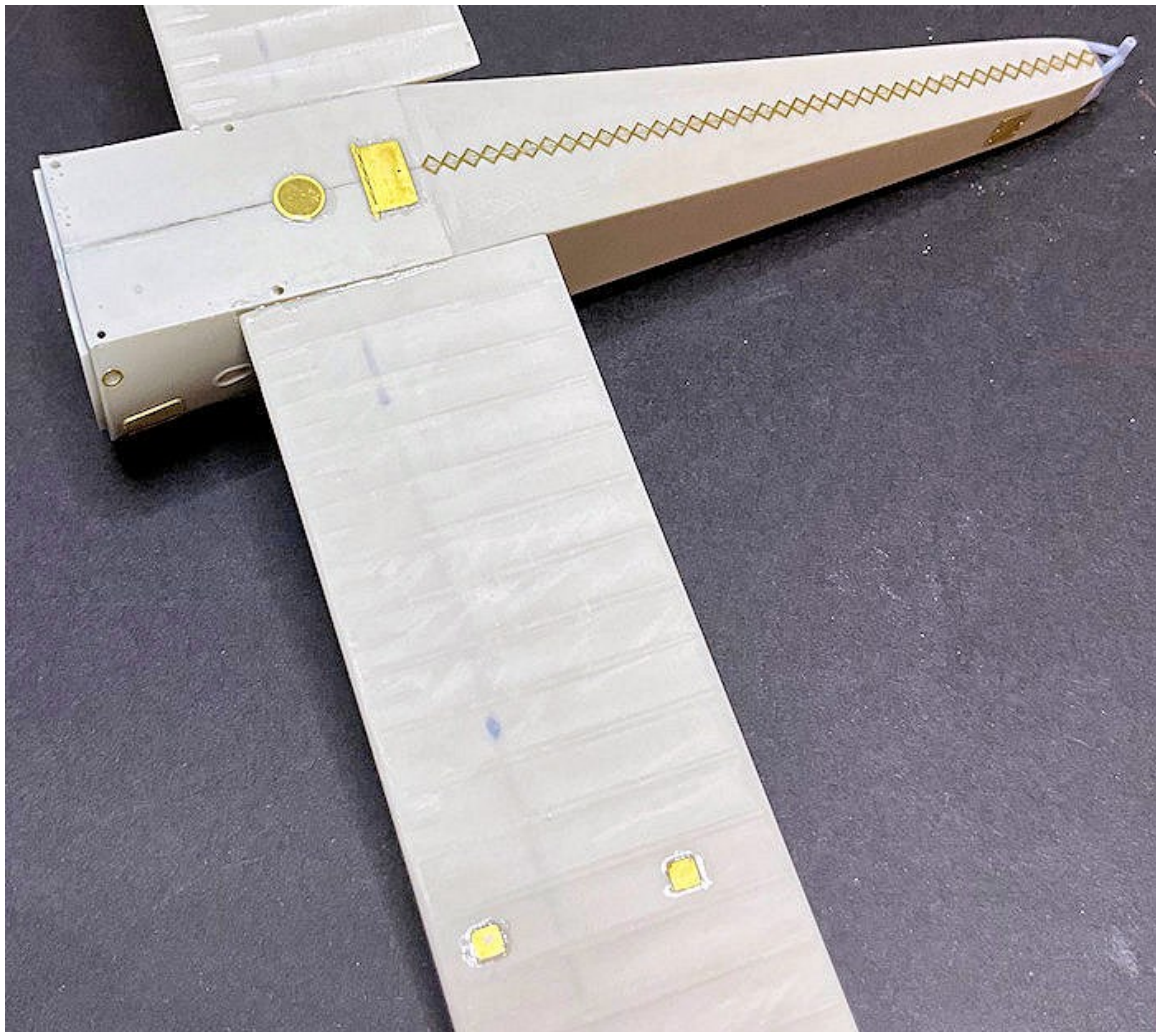

Upper wing half underside.



Upper wing top surface.

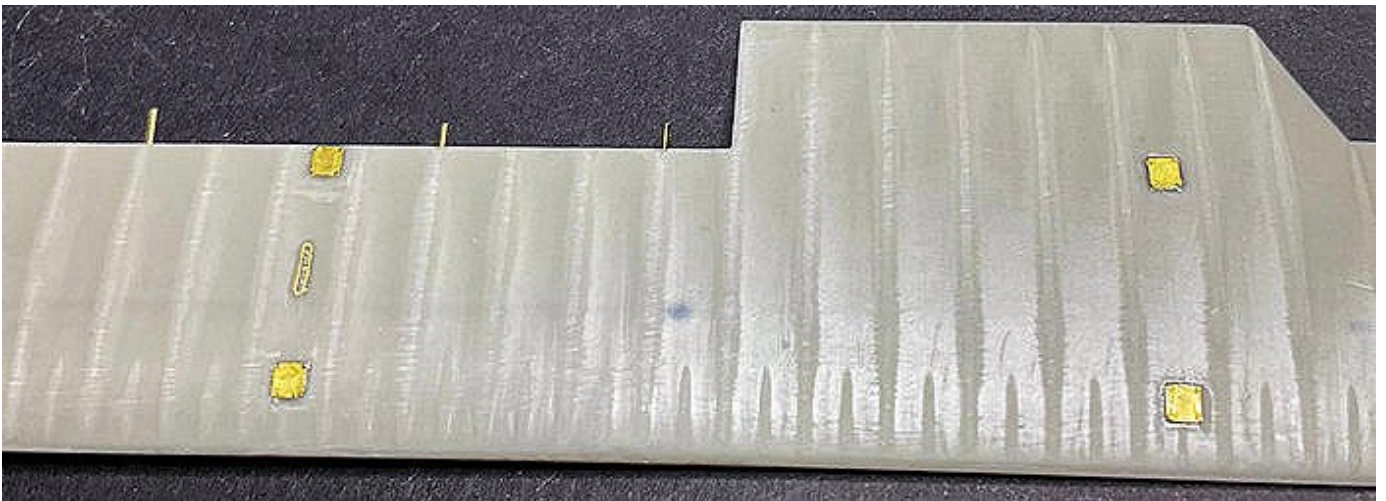

Lower wing top surface



Aileron and rudder.

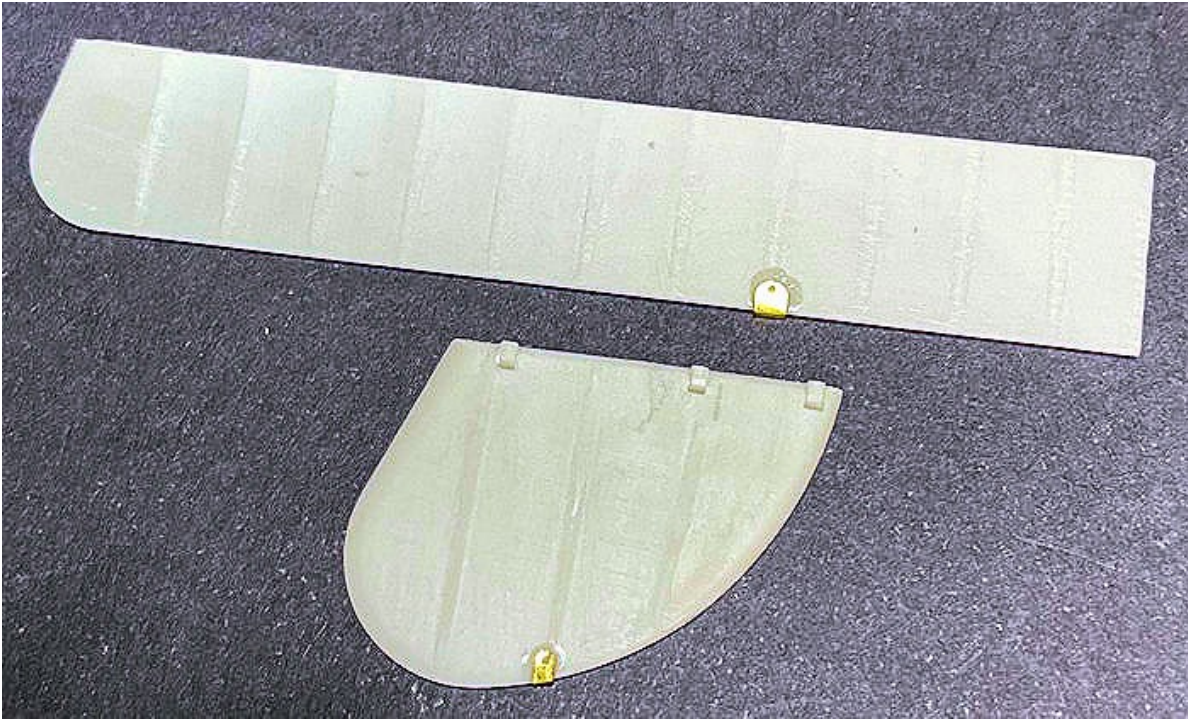

Strut locating holes:

Drill strut locating holes of 0.4 mm diameter for the side support and interplane struts into, **but not through**, the centre of the photo-etch parts 24, 25 and 26 on the underside of the upper wing and top surface of the lower wings. The holes should be drilled at the approximate angles of the struts, when fitted.

Drill strut locating holes of 0.4 mm diameter for the tailplane support struts into the lower, rear of the fuselage (pre-molded rear recesses) and into, **but not through**, the underside of the tailplane (forward pre-molded recesses). The holes should be drilled at the approximate angles of the struts, when fitted.

Test fit of upper wing:

NOTE: *The following procedure is necessary to check the fit of the upper wing halves with the interplane and cabane support struts. The model will be painted with a four colour camouflage pattern and the forward fuselage is not linen covered, so will not require linen effect decals applied. Therefore the lower wings can be fitted at this stage of the build. Also the addition of the photo-etch strut base may affect the fit if the struts.*

Using CA adhesive, secure the lower wings fully into their locating holes drilled into the fuselage. Make sure the two wings are at 90 degrees to the fuselage centre line when viewed from above and are horizontal to the fuselage when viewed from the front.

NOTE: *During the following steps, handle the fitting of the 3D printed struts with care, as being brittle, too much flexing may break the struts.*

Temporarily fit the cabane strut assembly side support struts and interplane struts into their pre-drilled locating holes in the fuselage and lower wings. If necessary, hold the struts in position using 'UHU' White Tak or similar.

Carefully join the two upper wing halves together through the holes in the top of the cabane strut assembly.

NOTE: *At this stage of the build I found that the cabane inner support struts were too short and did not reach the underside of the upper wing. Therefore I modified the model as follows:*

Remove the upper wing and side support and interplane struts.

Cut away the two holed wing rod supports on the top of the cabane strut assembly.

Drill a hole of 0.3 mm diameter into, **but not through**, the top bar of the cabane struts, above the join of the inverted support 'V' bars.

Cut two lengths of 0.3 mm diameter Brass rod, such as that from 'Albion alloy's' or similar.

Secure the rod into the pre-drilled holes in the cabane bar.

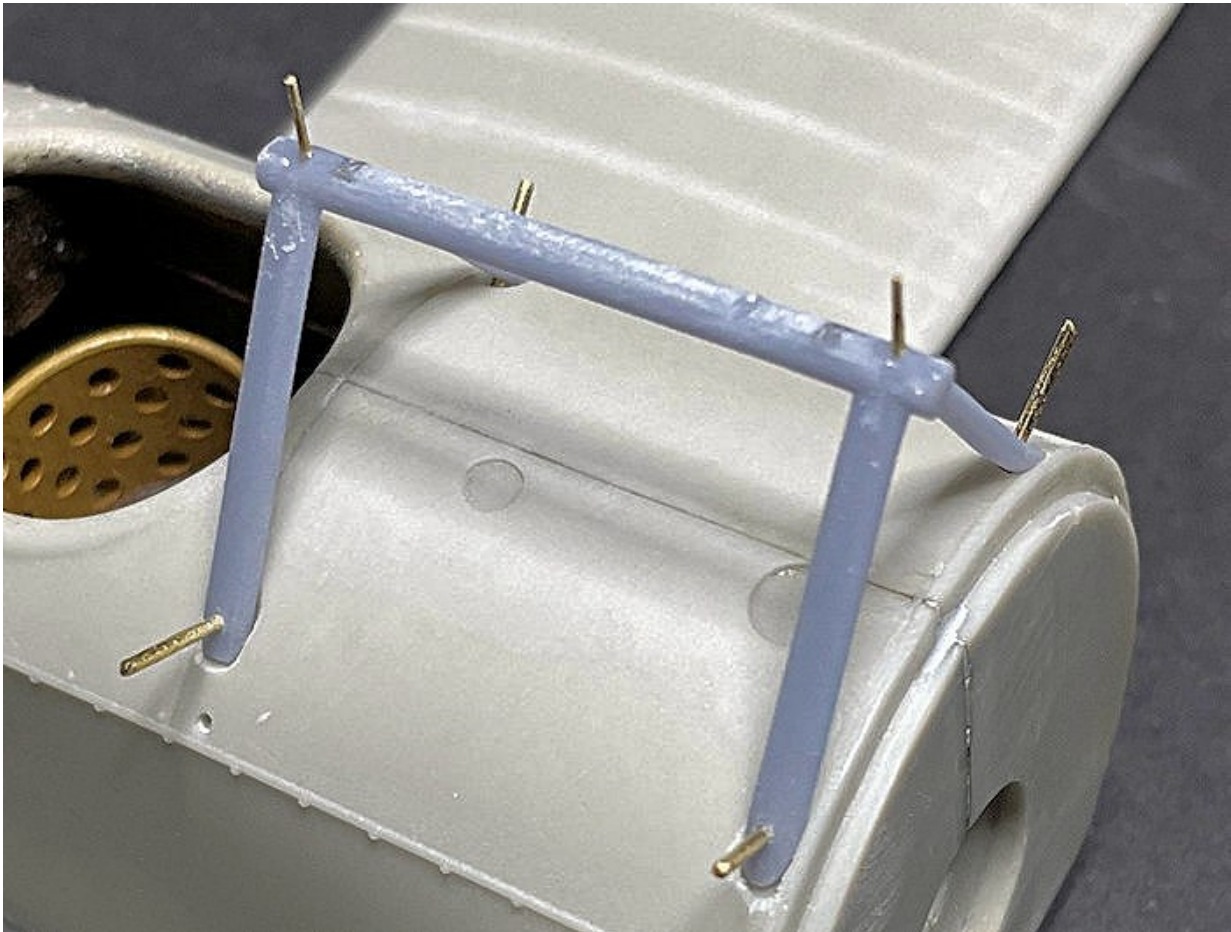

Join together the two upper wing halves together leaving a slight gap between the wing roots.

Locate the wing assembly over the protruding rods then gently push the wing halves together against the rods.

NOTE: *During the following step, make sure all of the struts fully locate into the upper wing with no gaps showing between the struts ends and wings and fuselage.*

Locate the top of the rods of the side struts and interplane struts into their pre-drilled locating holes in the underside of the upper wing. The lower wings should be horizontal and the upper wings should have a 3 degree dihedral angle (wing tips up).

Reduce the height of the rods such that they are flush with the top surfaces of the upper wing halves.

Remove the upper wing halves and all struts for fitting later in this build.

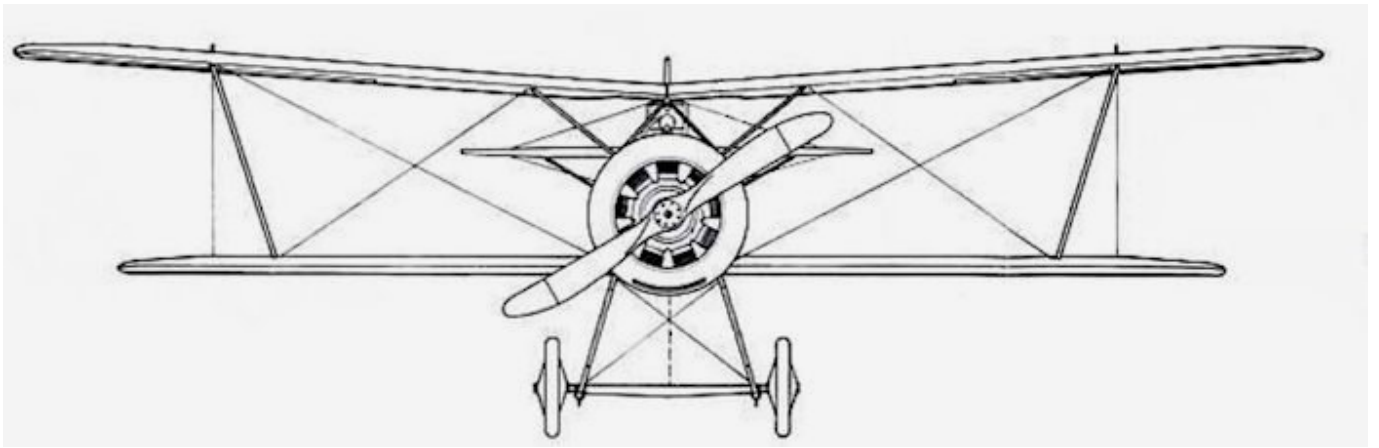

Tailplane support struts:

Temporarily fit the tailplane to its locating rods on the top, rear of the fuselage.

Test fit the two tailplane support struts into the pre-drilled hole at the lower, rear of the fuselage and the underside of the tailplane, making sure the struts fully locate.

Remove the struts and tailplane for fitting later in this build.

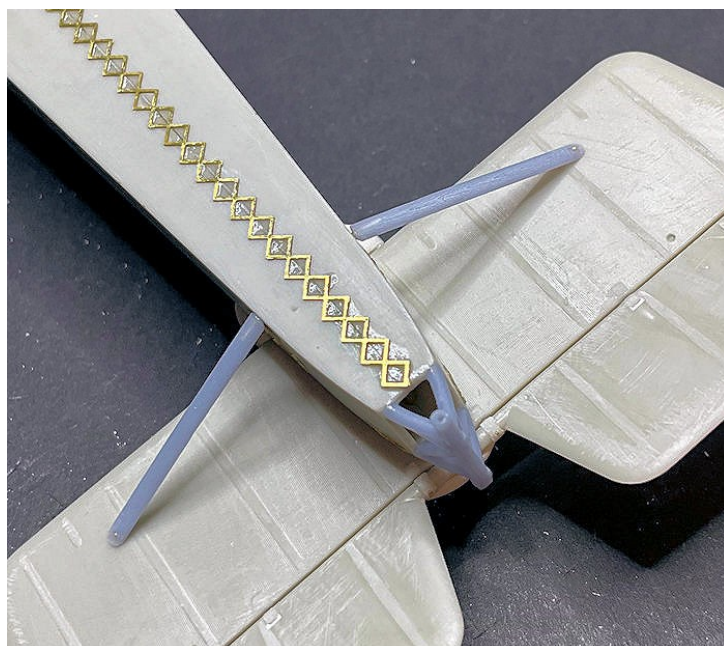

Pre-rigging:

NOTE: The following steps are to provide locating holes for the fitting of 'Gaspatch' metal turn-buckles, as the kit supplied photo-etch rigging points have been removed as being too weak for the mono-filament rigging line to be used. **Refer to Part 6 (Rigging - General)** for information of the aircraft external rigging.

All rigging holes should be drilled at the approximate angle to align with the opposite end of the lines when parts are fitted. For example, flying wire holes between the fuselage and underside of the upper wings when fitted onto the interplane struts.

Fuselage:

Twin flying wires:

Drill two holes of 0.3 mm diameter into both sides of the fuselage inside the two flying wire recesses.

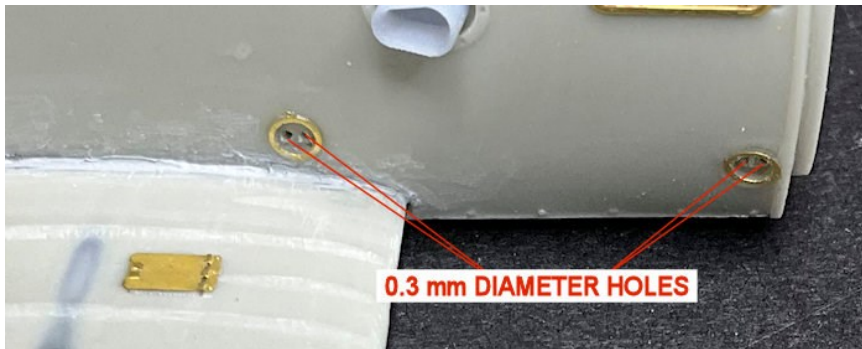

Underside of upper wings:

Twin flying wires:

Drill two holes of 0.3 mm diameter into, **but not through**, the underside of the upper wings, inboard from each of the outer photo-etch mounting plates for the interplane struts.

Single landing wires:

Drill a hole of 0.3 mm diameter into, **but not through**, the underside of the upper wings, outboard from each of the inner photo-etch mounting plates for the side support struts.

Crossed incidence wires:

Drill a hole of 0.3 mm diameter into, **but not through**, the underside of the upper wings, between each of the outer photo-etch mounting plates for the interplane struts.

Using thin CA adhesive, secure a 'Gaspatch' 1:48th scale Anchor Point into each of the drilled holes.

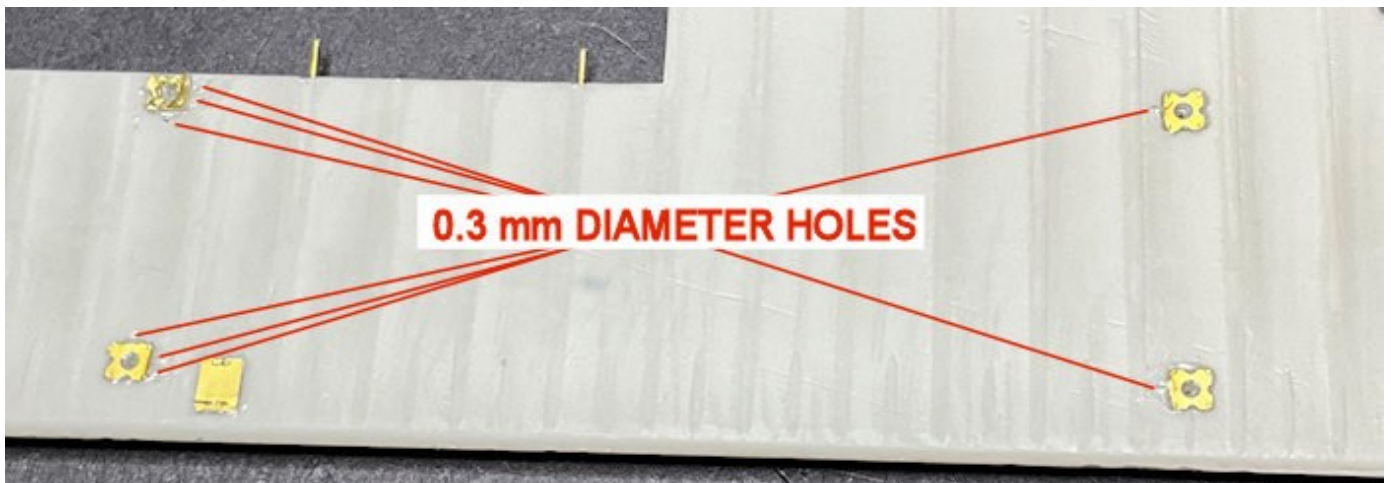

Top surface of lower wings:

Single landing wires:

Drill a hole of 0.3 mm diameter into, **but not through**, the top surface of the lower wings, inboard from each of the outer photo-etch mounting plates for the interplane struts.

Using thin CA adhesive, secure a 'Gaspatch' 1:48th scale Anchor Point into each of the drilled holes.

Crossed incidence wires:

Drill a hole of 0.3 mm diameter into, **but not through**, the top surface of the lower wings, between each of the four photo-etch mounting plates for the interplane struts.

Using thin CA adhesive, secure a 'Gaspatch' 1:48th scale Anchor Point into each of the drilled holes.

Aileron control cable:

Drill a hole of 0.3 mm diameter into, **but not through**, the top surface of the upper wings, in the added photo-etch aileron plate.

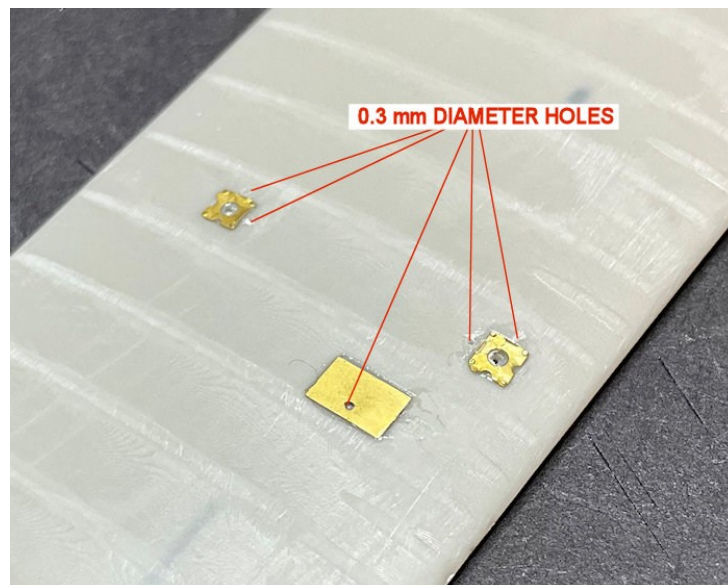

Top surfaces of upper wings:

Wing aileron control cable:

Drill a hole of 0.3 mm diameter into, **but not through**, the top surface of the upper wings, inside the added photo-etch surrounds.

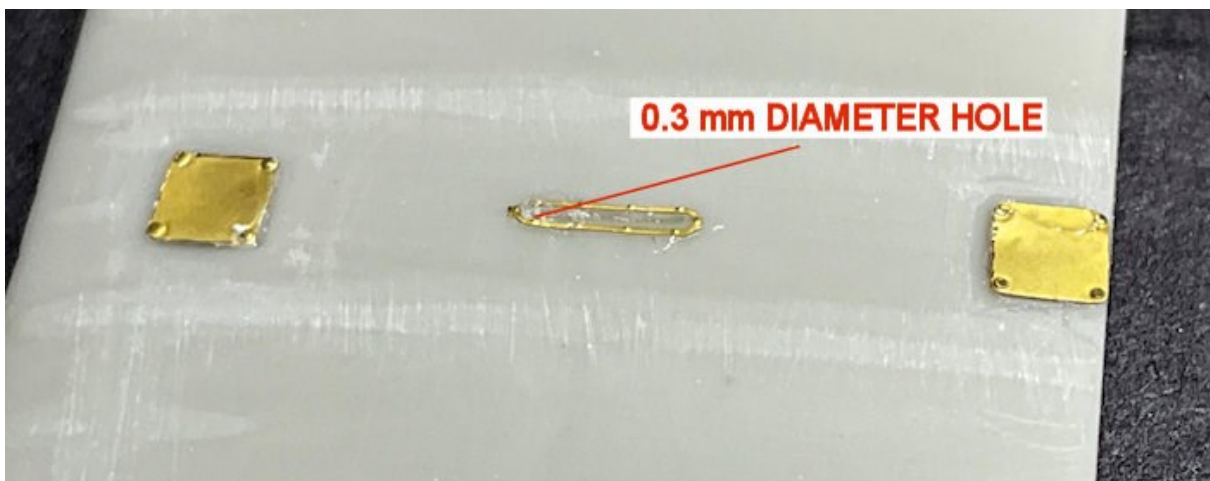

Ailerons:

Aileron control cables:

To represent the aileron control cable lever under the ailerons - Drill a hole of 0.3 mm diameter into, **but not through**, the underside of the ailerons, using as a guide the small pre-molded recess toward the leading edge of the ailerons (aligned to the added trailing edge photo-etch). Using thin CA adhesive, secure a 'Gaspatch' 1:48th scale Anchor Point into the drilled holes.

Drill a hole of 0.3 mm diameter through the added photo-etch on the trailing edge of the ailerons.

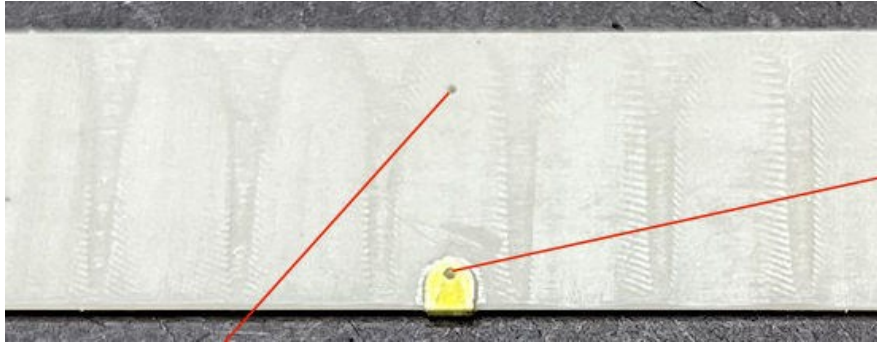

Rudder:

Rudder bracing wire:

Drill a hole of 0.3 mm diameter through the added photo-etch on the trailing edge of the rudder.

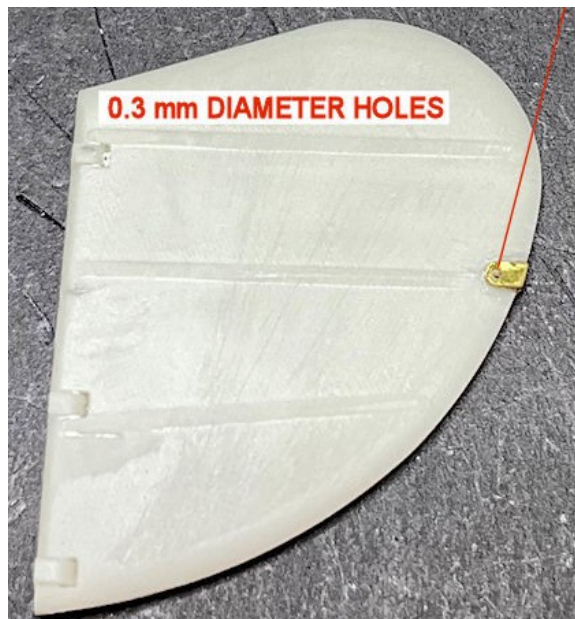

Rudder control cables:

Drill holes of 0.8 mm diameter along and inside the added photo-etch rudder cable ports on the rear of the fuselage.

Angle the drill to drill out the remaining residual resin to create the slots.

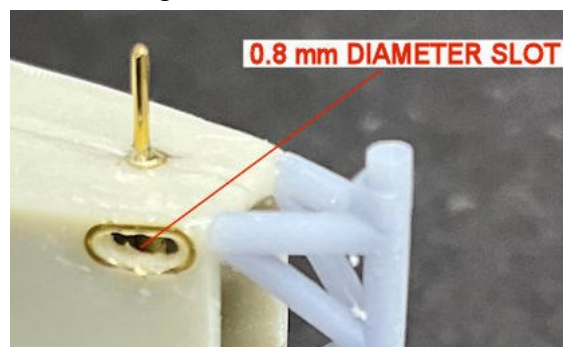

Elevator control cables:

The elevator control cables are attached to the elevator torsion bar within the rear of the fuselage. The ends of the cables are not really visible externally.

Tailplane and Fin bracing wires:

Drill a hole of 0.3 mm diameter through the trailing edge of the tailplane inboard from the outer hinges.

Drill a hole of 0.3 mm diameter through the trailing edge of the fin, just below the upper hinge.

NOTE: *During the following step, avoid the added internal Brass locating rod.*

Drill a hole of 0.3 mm diameter through the rudder post of the fitted 3D printed support assembly for the tail skid.

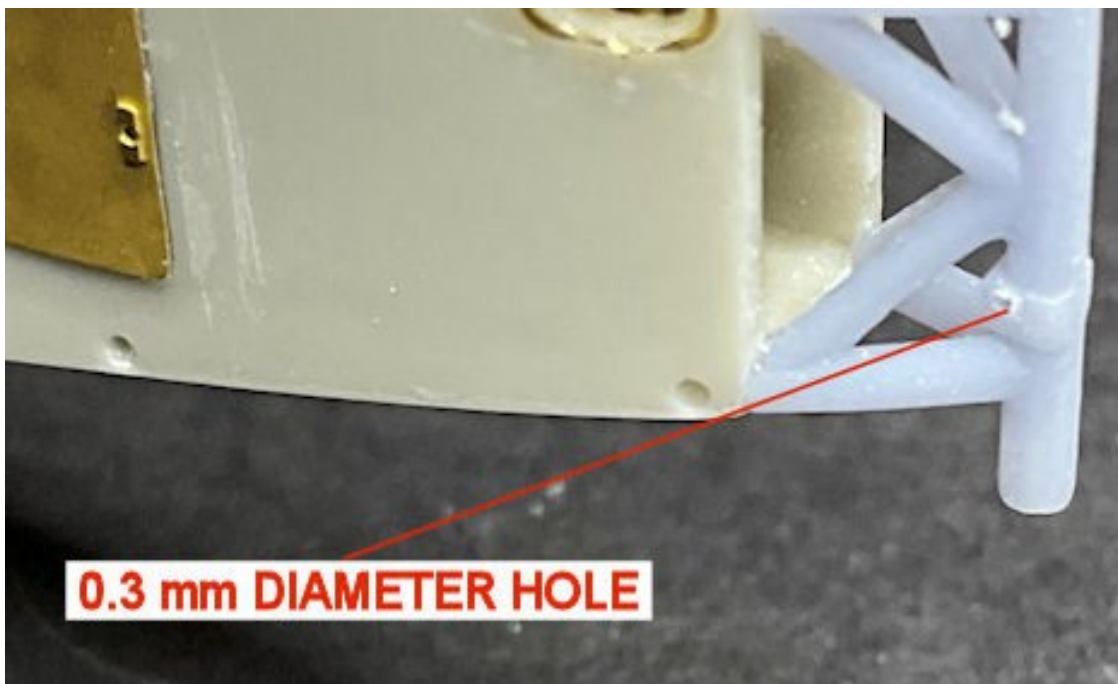
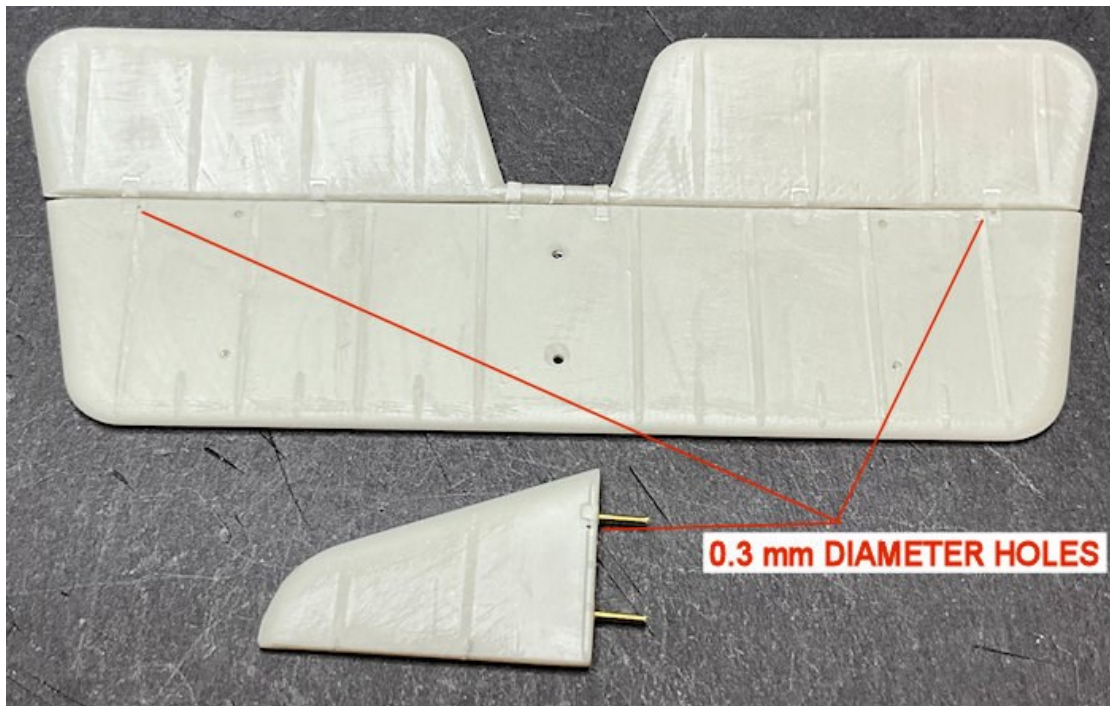

Landing gear:

Crossed landing gear bracing wires:

Drill a hole of 0.3 mm diameter through the lower, centre of both forward struts of the 3D printed landing gear assembly.

NOTE: *During the following step, avoid drilling into the added Brass locating rods.*

Drill a hole of 0.3 mm diameter through the top, rear of both rear struts of the 3D printed landing gear assembly.

Axle bracing wire:

Drill a hole of 0.3 mm diameter centrally into the leading edge of the axle fairing. The holes should be drilled approximately 1.0 mm inboard from the 'bungee' suspension cord.

Using thin CA adhesive, secure a 'Gaspach' 1:48th scale Anchor Point into each of the drilled holes.

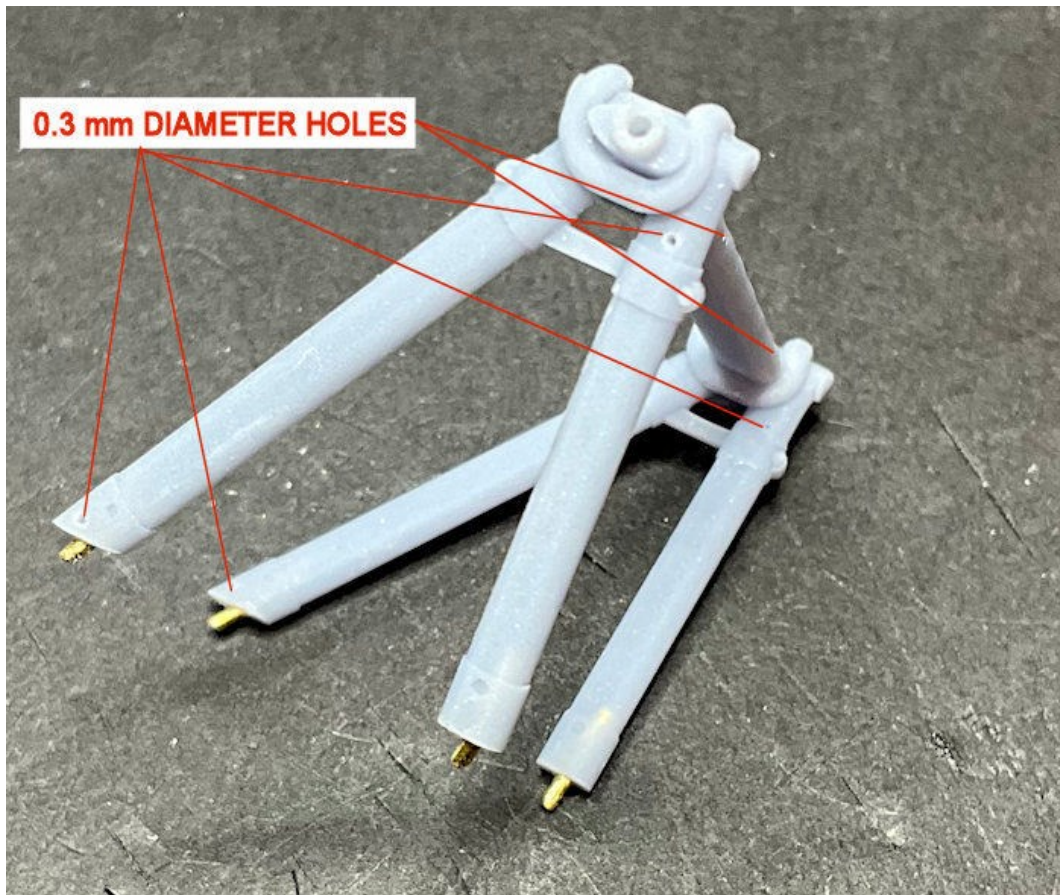

Filling joints and photo-etch edges:

NOTE: *Some of the photo-etch panels on the fuselage are smaller than the pre-molded panel surrounds which are visible once the photo-etch panels are secured in place.*

Brush 'Mr. Surfacer' 1000 around the edges of the fitted photo-etch panels to fill the pre-molded surrounds and if necessary, the lower wings to fuselage joints.

Once fully set, use a cotton bud or brush, dampened with 'Mr. Colour' levelling thinners to remove the excess surfaces to leave a filled and smooth surface.

Carefully sand down the added under fuselage photo-etch stitching to reduce it to a more in-scale thickness.

Painting:

NOTE: The following illustration shows the typical French camouflage scheme used on Belgian Harriot HD.1 aircraft. The undersides were most likely left in the manufacturers Aluminium dope colour. The upper surfaces of the tailplane and elevator of Willy Coppens aircraft were white and blue 'sunray' stripes.

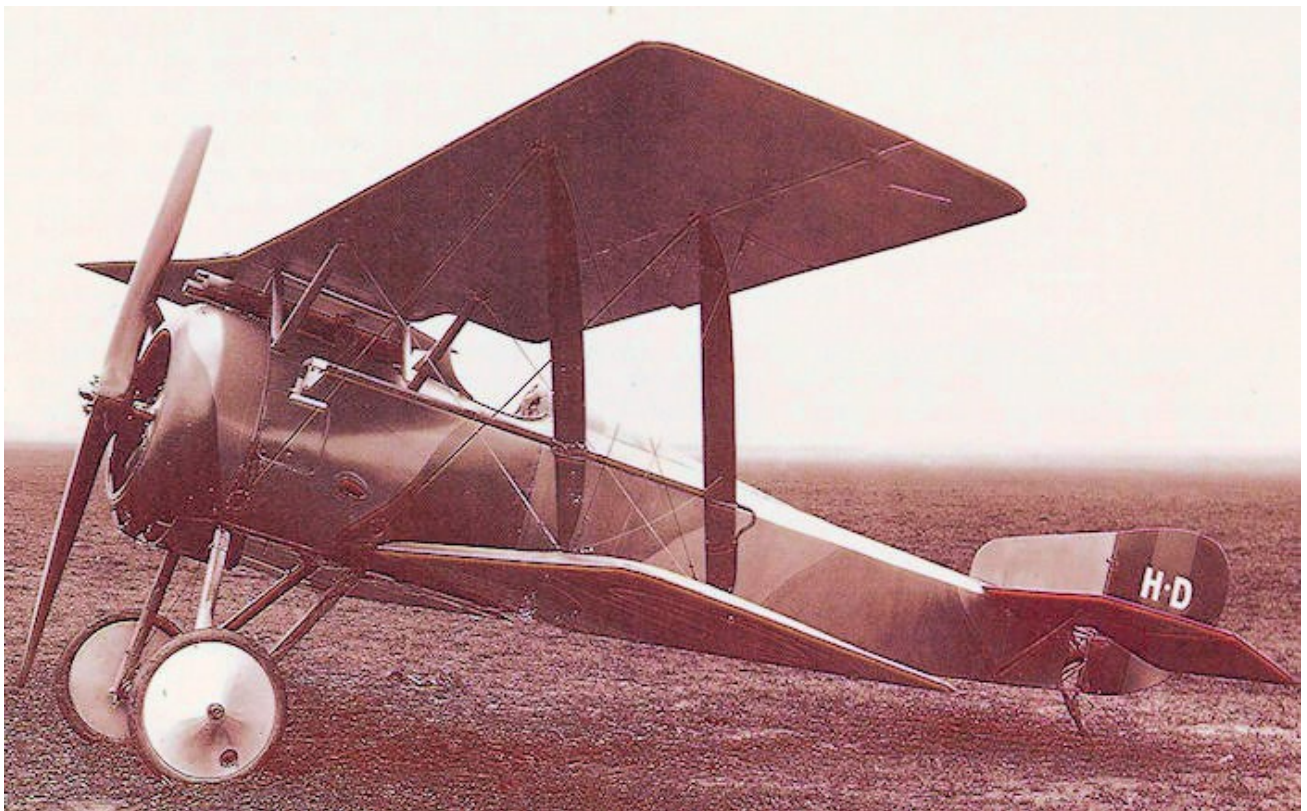
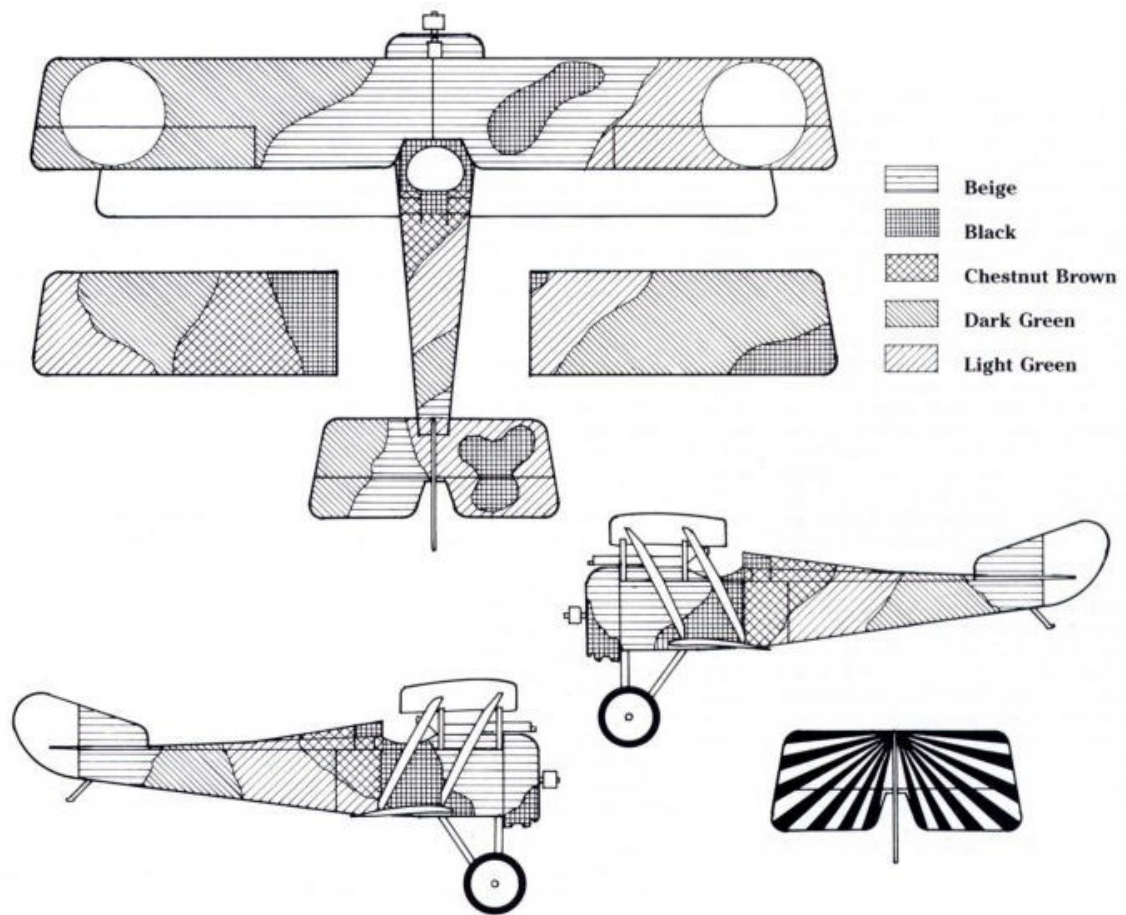

Airbrush a grey primer, such as 'AK Interactive' Grey (AK758) or similar over all of the prepared model parts.

NOTE: *Applying a black primer will provide a good reflective base coat for the final Aluminium top coat.*

Airbrush prime the **undersides** following parts with black, such as 'Tamiya' Gloss Black (X1) or similar:

- Fuselage
- Lower wings
- Upper wing halves
- Ailerons
- Tailplane
- Elevator.

To lessen the metallic finish, airbrush the same surfaces with a **light coat** of 'Tamiya' Light Blue (XF23) or similar.

Airbrush prime the following parts with black, such as 'Tamiya' Gloss Black (X1) or similar:

- Engine bulkhead (front of fuselage)
- Inside the 3D printed engine cowl.

Airbrush the same surfaces with 'Alclad' Duraluminium (ALC102) or similar.

NOTE: *Period photographs indicate that the five colour camouflage scheme was probably brush painted as the edges of the various colours were 'hard edged', not overlapping and blurred, as with airbrushing.*

The colours used are listed below and should be applied with the lightest colour first, in the following order:

- Beige - 'Hataka' C060 USMC Sand*
- Light Green - 'Hataka' C093 Green (FS34258)*
- Dark Green - 'Hataka' C301 Dark Olive Green (FS34096)*
- Chestnut Brown - 'Tamiya' Flat Brown (XF10)*
- Black - 'Tamiya' NATO Black (XF69).*
- Smoke - 'Tamiya' Smoke (X19).*

Temporarily fit the two ailerons onto the upper wing halves.

Mask off the upper surfaces of the wings/ailerons and the fuselage for the Beige areas.

Airbrush the exposed areas and the windscreen frame with the 'Hataka' USMC Sand.

Remove the masking.

Mask off the upper surfaces of the wings/ailerons and the fuselage for the Light Green areas.

Airbrush the exposed areas with the 'Hataka' Light Green.

Remove the masking.

Mask off the upper surfaces of the wings/ailerons and the fuselage for the Dark Green areas.

Airbrush the exposed areas with the 'Hataka' Dark Olive Green.

Remove the masking.

Mask off the upper surfaces of the wings/ailerons and the fuselage for the Chestnut Brown areas.

Airbrush the exposed areas with the 'Tamiya' Flat Brown.

Remove the masking.

Mask off the upper surfaces of the wings/ailerons and the fuselage for the Black areas.

Airbrush the exposed areas with the 'Tamiya' NATO Black.

NOTE: *The top surfaces of the tailplane and elevator were white 'sunray' stripes on a blue base colour.*

Airbrush the top surfaces of the tailplane and elevator with 'Tamiya' Medium Blue (XF18) similar.

Decals:

NOTE: *The kit supplied decals are all printed as part of the sheets carrier film. Therefore they are not separate decals, but need to be individually cut out and as close as possible to the edges of the decal, to avoid excess carrier film showing once the decal has been applied. Also the decals are slightly translucent, meaning once applied to the model, the underlying paints, especially at colour change, may show through the decal.*

Airbrush the following areas with a clear gloss coat, such as 'Alclad' Aqua Gloss 600 or 'Mig' A-Stand Aqua Gloss (A.Mig-2503):

- Outer undersides of the lower wings
- Outer top surface of the upper wings
- Middle of the fuselage sides
- Both sides of the rudder
- Top surface of the tailplane and elevator.

Cut out the following decals from the supplied sheet:

- Upper wing roundels (larger)
- Lower wing underside roundels
- Fuselage 'Thistle' emblem
- Rudder stripes
- Tailplane/elevator 'sunray' stripes.

Temporarily fit the ailerons to the upper wing halves.

Position the upper wing roundel and lightly mark the decal edges where the wing to aileron separation is located.

Carefully cut the decal across the marked edges to separate the decal into wing and aileron parts.

Temporarily fit the elevator to the tailplane.

Position the 'sunray' stripes on tailplane and elevator and lightly mark the decal edges where the tailplane to elevator separation is located.

Carefully cut the decal across the marked edges to separate the decal into tailplane and elevator parts.

NOTE: *If necessary, refer to Part 4 (Decals) of this build log and page 11 of the kit instructions for decal positioning.*

Apply the upper wing roundel decals to the top surfaces of the wing halves.

Apply the upper wing aileron decals to the top surfaces of the ailerons.

Apply the lower wing roundel decals to the underside of the lower wings.

Apply a rudder stripes decal to one side of the rudder and allow it to dry and set in position.

Apply the rudder stripes decal to the other side of the rudder, making sure the tops and bottoms of the stripes align.

Once the rudder decals have dried and set, apply the 'H.D 24' decals to both sides of the rudder.

Apply the 'sunray' stripes to the tailplane.

Apply the 'sunray' stripes to the elevator.

NOTE: The 'Thistle' decals and the small white 'lever ici' (lift here) decals will be applied later in this build, to avoid damaging them whilst holding the model by the fuselage.

If necessary, brush 'Microscale' MicroSol over and around the edges of decals to conform them to the model surfaces.

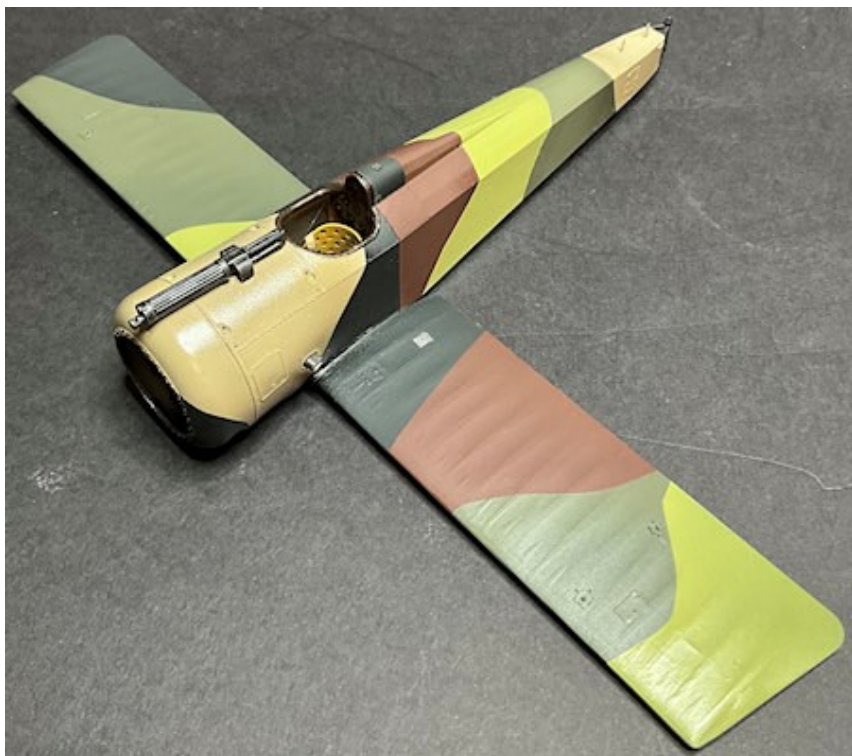

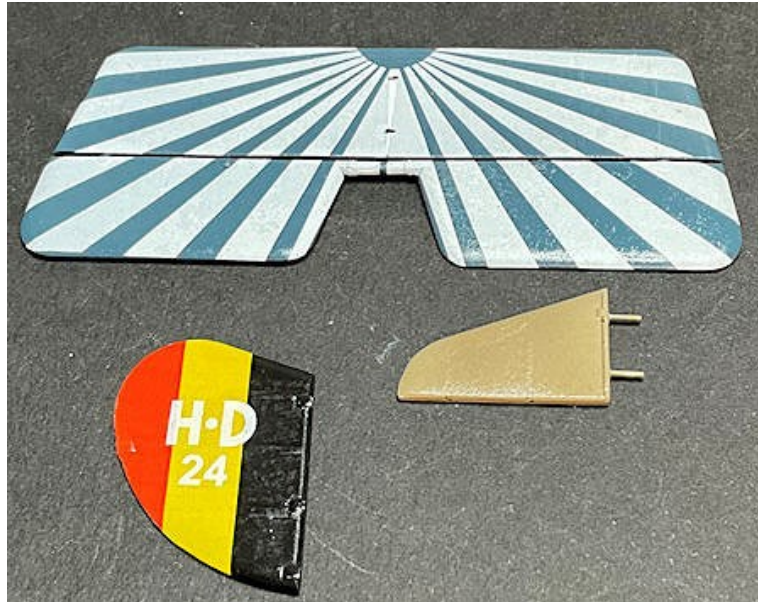

Assembly:

Make sure all primer and paint is removed from the engine rear locator and its locating hole in the front of the fuselage.

Make sure all primer and paint is removed from the mating faces at the forward fuselage and rear edge of the engine cowl.

Using CA adhesive, secure the engine into its locating hole and recess at the front of the fuselage.

NOTE: *During the next step, make sure the long cut-out in the engine cowl is positioned at the bottom and positioned centrally to the fuselage underside.*

Using thin CA adhesive, secure the engine cowl over the engine onto its locating shoulder around the front of the fuselage.

Remove the photo-etch windscreen surround from the kit supplied sheet and remove any residual tags from its edges.

Lay the windscreen surround onto the kit supplied acetate sheet.

Hold the surround on the sheet and carefully cut around the edges of the surround to create the acetate windscreen.

Hold the surround and acetate in tweezers, making sure both are aligned.

Apply a small amount of thin CA adhesive to secure the edges together, pinching the two together if necessary.

Clean away any primer or paint from the mating surfaces of the windscreen recess in the windscreen frame.

Apply a small amount of thin CA adhesive to secure the windscreen to its recess in the frame.

Brush paint the photo-etch windscreen surround with 'Hataka' C060 USMC Sand or similar.

Modifications:

Propeller shaft:

NOTE: *I found that once the engine and engine cowl was fitted, the engine propeller shaft was not long enough to clear the engine cowl to allow the propeller to be fitted.*

Cut away the engine propeller shaft.

Centre point the witness mark where the propeller shaft was located.

Using the point mark as a guide, drill into the engine from 0.5 mm diameter and gradually increase to 1.4 mm diameter.

Cut a length of 1.4 mm diameter Brass tube, such as 'Albion Alloy's' MBT14 or similar.

Secure the tube into the pre-molded hole in the rear of the propeller hub.

File or sand the end of the propeller tube so when inserted into the hole in the engine, the rear of the propeller is clear of the engine cowl.

NOTE: *The following step is required to increase the diameter of the modified propeller shaft to be more in-scale.*

Cut a short length of 2.0 mm diameter tube, such as 'Albion Alloy's' MBT20 or similar.

The length of the tube should be such that when slid onto the modified propeller shaft, it covers the shaft between the engine and rear of the propeller.

Secure the tube onto the propeller shaft using thin CA adhesive.

Brush paint the tube with 'Mr. Colour' Stainless Steel (213) or similar.



Windscreen:

NOTE: *The edges of the windscreen should be angled slightly, as shown in the following photograph.*

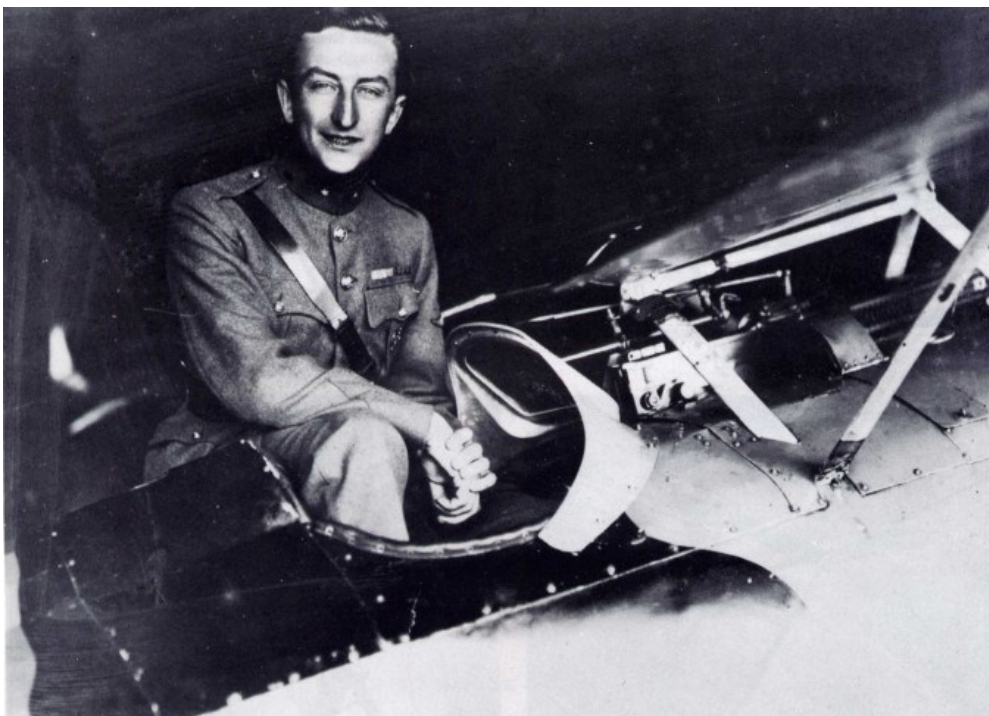

Test fit the windscreen assembly onto the fuselage decking panel just forward from the cockpit surround padding.

As necessary, carefully file or sand the trailing edges of the windscreen to the angle shown in the photograph.

Tail skid suspension:

NOTE: The tail skid had 'bungee' type cord fitted around the tail skid and its support frame.

Also, the rudder post on the kit supplied tail skid support structure is too long at the bottom.

The 3D printed tail skid **broke in half** when I was test fitting it, which was not surprising given how brittle the resin used is. Therefore I scratch built a replacement from 1.2 mm Brass tube with 0.5 mm diameter Brass rod, all soft soldered together and subsequently painted.



Carefully cut away the bottom of the rudder post to just below the attachment fitting.

Drill a hole centrally up into the cut rudder post, using a 0.5 mm diameter drill.

Test fit the added rod in the tail skid up into the rudder post with the top of the tail skid up between the bars of the support structure.

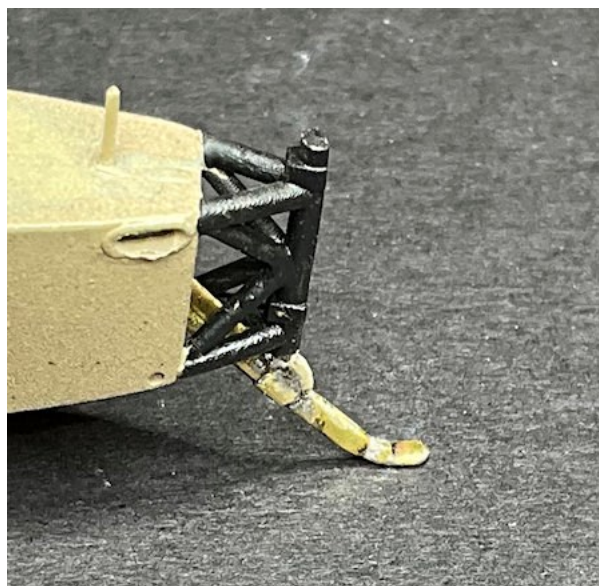

Using thin CA adhesive, secure the tail skid fully into its pre-drilled hole in the bottom of the rudder post, making sure the tail skid rest on the bottom edge of the fuselage.

Cut a long length of 'EZ' White stretch line (heavy).

Using thin CA adhesive, secure one end of the line to the tail skid inside the support structure. Route the line diagonally up and over the double support bars at the front edge of the rudder post.

Route the line diagonally down around the tail skid to the secured end of the line, Secure the line on the tail skid using thin CA adhesive.

Continue to wrap the line around the support bars and tail skid twice more, then secure the line at the underside of the tail skid using thin CA adhesive.

Carefully cut away the residual line.

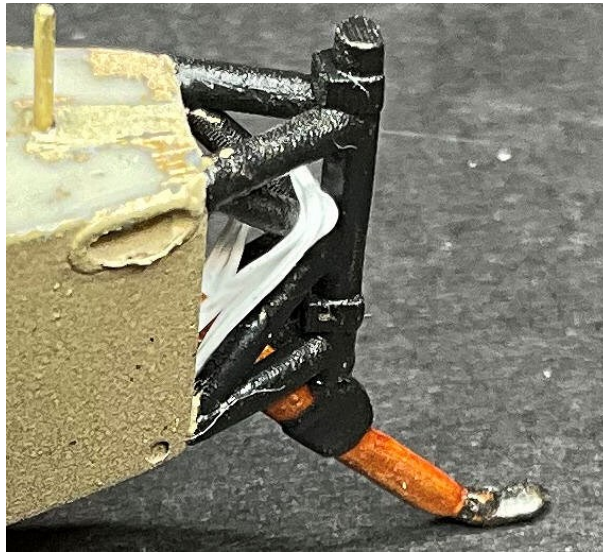

Painting (continued):

Airbrush the tyres of the wheels with a semi-black gloss, such as 'Tamiya' Semi-Gloss Black (X18) or similar.

NOTE: *To airbrush the wheel covers on both wheels, without over spraying the surrounding tyres, I use a circle drawing tool (Linex 1217 T).*

Select the best sized hole in the drawing tool that matches the covers (not including tyres) of the wheels. Position the wheel under the hole.

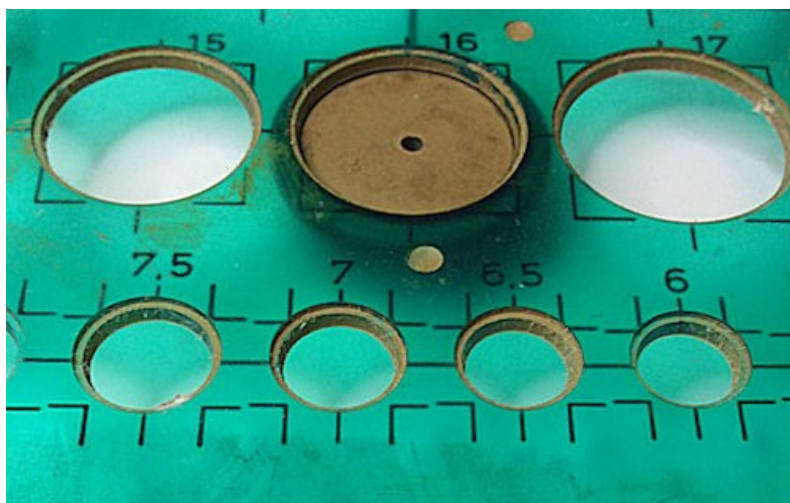

Airbrush the following parts with 'Alclad' Duraluminium (ALC102) or similar.

- Frone and rear wheel covers
- Landing gear assembly
- Cabane strut assembly
- Four cabane side struts
- Two support struts for tailplane.

To lessen the metallic finish, airbrush the same surfaces with a **light coat** of 'Tamiya' Light Blue (XF23) or similar.

Airbrush the following parts with 'Tamiya' Desert Yellow (XF59) or similar.

- Four interplane struts
- Tail skid
- Windscreen.

Brush paint the following with 'Tamiya' Rubber Black (XF85) or similar:

- Ends of axle on the landing gear assembly
- Ends of axle on outer wheel covers
- Tail skid support structure (rear of fuselage).

Brush paint the following with 'Tamiya' Metallic Grey (XF56) or similar:

- Fuselage filler caps (x 3)
- Carburettor air intakes (fuselage sides)
- Inflation valve inside outer wheel covers.

Brush paint the 'bungee' suspension cords around the axle of the landing gear assembly, with 'Tamiya' Buff (XF57) or similar.

Leather effect:

NOTE: *The following is required to blend the cockpit surround padding with the existing leather cockpit detail.*

Brush the cockpit surround padding with 'Abteilung 502' Smoke oil paint.

Brush the cockpit surround padding with 'Windsor & Newton' Griffin Alkyd Burnt Sienna oil paint.

Lightly dampen a brush with White Spirits.

Use the side of the brush to dab the Burnt Sienna oil paint to lift the paint and create a leather look, leaving the darker Smoke oil paint in the recesses.

Leave the oil paint to fully dry. It should be touch dry in an hour or so and fully dry within 12 hours.

Wood effects:

NOTE: *Refer to Part 2 (Wood Effects) of this build log for more information. The method I used is Method 2, using 'Windsor & Newton' Griffin (Alkyd) oil paint.*

Apply the desired wood effect to the following parts. I used 'Windsor & Newton' Griffin (Alkyd) Burnt Sienna oil paint:

- Four interplane struts
- Tail skid.

Airbrush the struts and tail skid with light and thinned coat of 'Tamiya' Clear Orange (X26).



Brush paint the pilots foot step plate (left lower wing) with 'Mr. Colour' Stainless Steel (213) or similar.

Brush paint the metal fittings on the tail skid and at the ends of the four interplane struts with 'Tamiya' Rubber Black (XF85) or similar.

Brush paint the metal 'shoe' on the tail skid with 'Mr. Colour' Stainless Steel (213) or similar.

Assembly (continued):

Apply CA adhesive onto the bottom of the breech block of the prepared 'Vickers' machine gun and mounting lugs.

Secure the machine gun onto the decking panel of the fuselage.



Weathering:

NOTE: *During the following step, apply thin coats only, as the surfaces have more weathering to be applied.*

To dirty the surfaces of the model, airbrush a light coat of thinned 'Tamiya' Smoke (X19) over the following model parts:

Fuselage and lower wings - Upper wing halves

Tailplane - Elevator

Ailerons

Fin

Rudder

Wheels

Landing gear assembly

Cabane side support struts

Cabane strut assembly.

NOTE: Refer to Part 2 (Weathering) of this build log.

Lightly airbrush a semi-matte clear coat, such as 'Alclad' Light Sheen (ALC-311) or similar, over the same model parts. This will provide a good base for applying weathering.

Apply weathering, as desired, to the same model parts. I used 'Flory Models' Dark Dirt fine clay wash.



Wash applied

Wash applied



Once the desired effect is achieved, lightly airbrush coat of a semi-matte clear coat, such as 'Alclad' Light Sheen (ALC-311) or similar, over the model parts. This will seal and also protect the applied weathering.

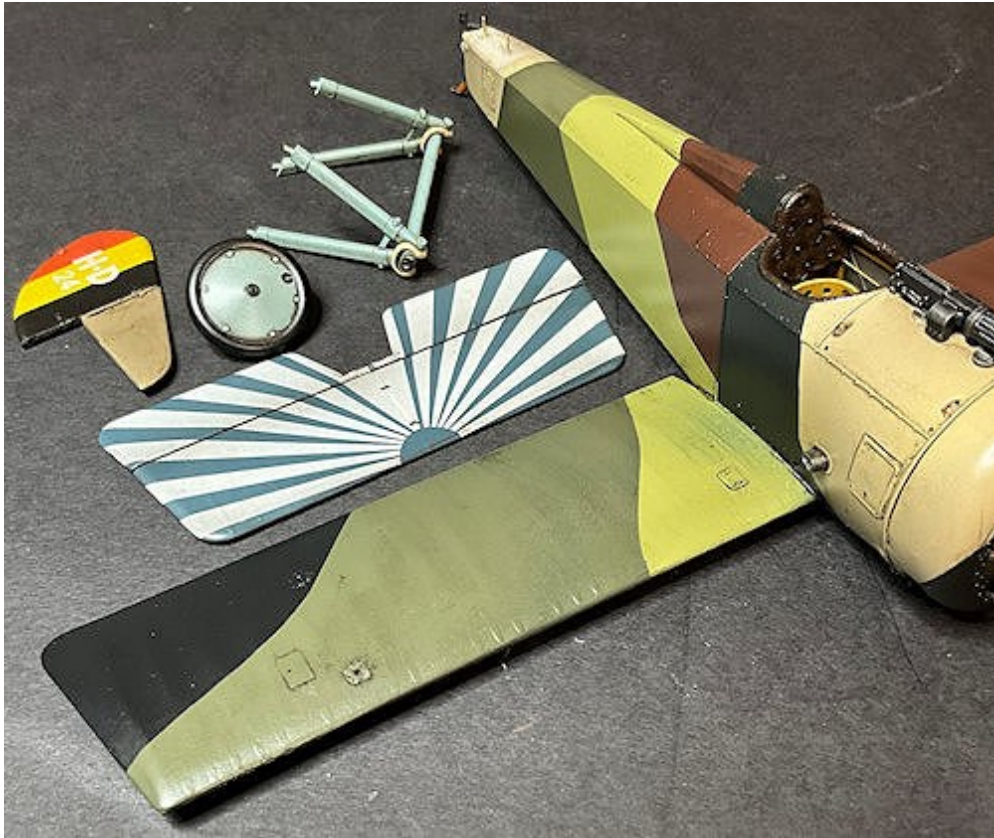

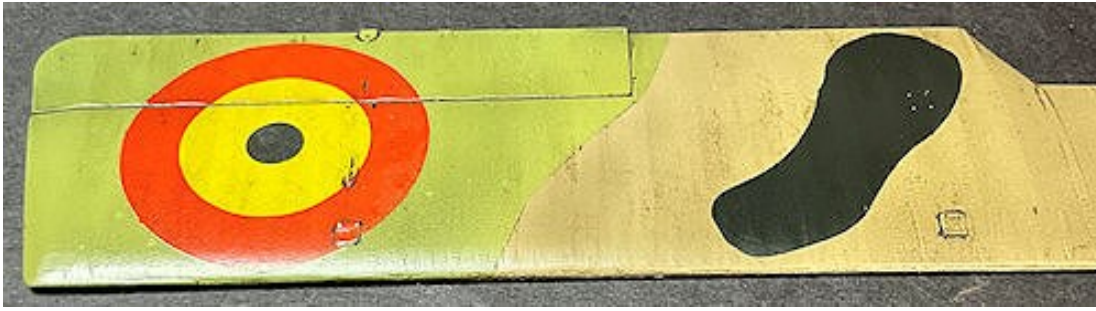

Dry brush the following with 'Mr. Colour' Super Iron 2 (SM203) or similar:

- The riveted ring on the front of the engine cowl
- Wing and fuselage metal panels
- The leading edges of the tail skid support frame.

Pre-rigging preparation:

Photo-etch parts:

NOTE: I chose to discard the kit supplied photo-etch aileron control horns 28b and 28c. These parts are very thin and are intended to be secured together and they don't really add any benefit to the rigging. The parts that were used needed to be modified as the rigging will be mono-filament.

Do not cut away the photo-etch tag on the bottom of parts 28a and 31, as these will be used to help secure the parts into their locations on the model parts.

Remove parts 28a (x 2), 32 (x 2) and 31 from the kit supplied photo-etch sheet.

Cut away any residual photo-etch tags from the edges of the parts.

Cut away the photo-etch rigging from aileron control horns 28a.

Drill holes of 0.3 mm diameter through the control horns. One hole should be drilled through the top of the control horns and a second hole drilled below and to the rear, angled edge.

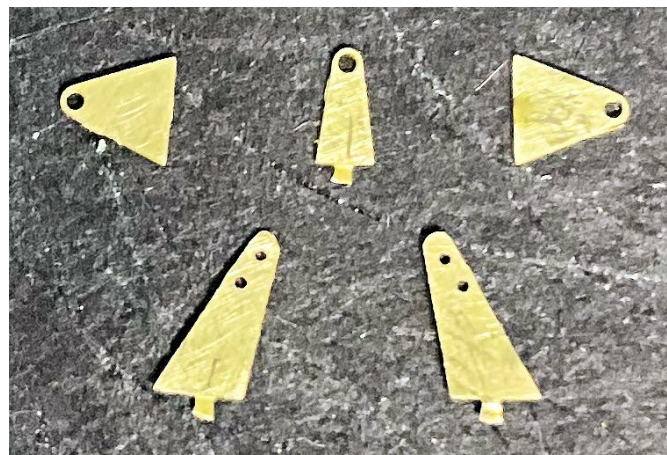

Rigging locating holes:

NOTE: Refer to the earlier pre-rigging of this Part of the build log for pre-drilled locating holes.

Make sure all primer, paint or decal is removed from all of the previously drilled rigging locating holes in the fuselage, landing gear, wings, ailerons, fin, tailplane and rudder. If necessary, carefully clear the holes using a 0.3 mm diameter drill.

Structural pre-rigging:

CAUTION: The following rigging techniques are not easy to carry out. If you are not sure you can do this, I suggest you use the easier method of using 'EZ' stretch line and secure each end of a rigging line into the pre-drilled holes, using the CA adhesive. Secure one end in place then cut the line such that with a little tension, the other end can be secured in position.

NOTE: The following procedures apply to all of the specified wires. The rigging materials used are:

- 'GasPatch' Elite Accessories 1:48th scale metal turnbuckles (**One Ended**)
- 'Steelon' or 'Stroft GTM' Mono-Filament 0.12 mm diameter mono-filament line
- 'MFH' 0.4 mm diameter clear tube (P-957).

Flying wires:

No pre-rigging of flying wires is required as these wires have no turnbuckles visible.

Landing wires (x 4):

Cut a long length of the line.

Cut a short length of the clear tube.

Pass the line through the clear tube then through an 'eye' end of a turnbuckle.

Loop the line back and through the clear tube.

NOTE: The following step is necessary to allow the line to be able to move in the turnbuckle 'eye' end.

Slide the clear tube up to, **but not touching**, the 'eye' end of the turnbuckle.

Secure the line in the clear tube using thin CA adhesive.

Cut away any residual tag end of line at the clear tube end.

Incidence wires (x 4):

Repeat the previous procedure to create four incidence wires for the interplane struts.

Landing gear bracing wires (x 2):

NOTE: In the following step, use 'GasPatch' Elite Accessories 1:48th scale metal turnbuckles (Type C).

Repeat the previous procedure to create two bracing wires for the landing gear.



NOTE: The following procedures apply to all of the specified wires. The rigging materials used are:

- 'GasPatch' Elite Accessories 1:48th scale metal turnbuckles (**Type C**)
- 'Steelon' or 'Stroft GTM' Mono-Filament 0.12 mm diameter mono-filament line
- 'MFH' 0.4 mm diameter Clear tube (P-957).

Axle bracing wire (x 1):

Repeat the previous procedure to create an axle bracing wire, attached to both ends of a turnbuckle.

Control cable pre-rigging:

NOTE: The following procedures apply to all of the specified control cables. The rigging materials used are:

- 'GasPatch' Elite Accessories 1:48th scale metal turnbuckles (**Type C**)
- 'Steelon' or 'Stroft GTM' Mono-Filament 0.08 mm and 0.12 mm diameter mono-filament line.
- 'MFH' 0.4 mm diameter clear tube (P-957)
- Blackened 0.4 mm diameter Brass tube, such as 'Albion Alloy's' MBT04) or similar.

Brass tube can be chemically blackened by immersion in solutions, such as 'Black-It' or similar.

The specific kit supplied photo-etch parts required for the rudder, aileron and elevator control cables are numbered in the following photograph.

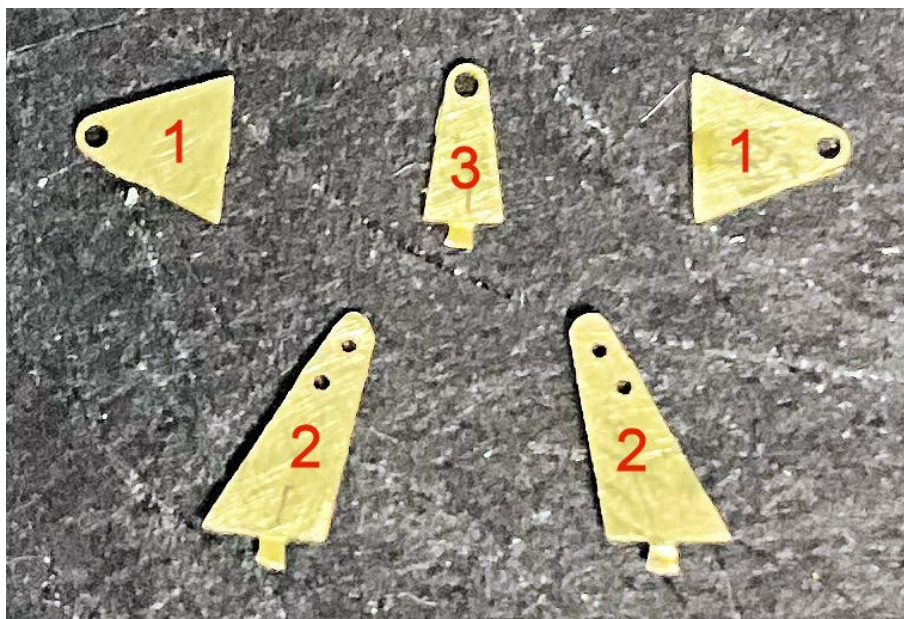

Rudder bracing wires (x 2)

Repeat the previous procedure to create a rudder bracing wire (0.12 mm diameter line), attached to one end of the turnbuckle.

Rudder control cables (x 2):

Cut a long length of 0.12 mm diameter line.

Pass the line through hole in photo-etch part 1.

Loop one end of the line over and back through the hole.

Position the photo-etch centrally on the line then pull the two lines to tighten the knot.

Hold the line taut and at 90 degrees to the photo-etch part then secure in position using thin CA adhesive.

Cut two short lengths of clear tube.

Pass the tubes onto the lines and position them close to the end of the photo-etch part 1.

Secure the tubes to the lines using thin CA adhesive.

Repeat to create the other rudder control horn.

Drill a hole of 0.3 mm diameter through the rear edge (opposite the added lines) of the photo-etch part and slightly lower. This will be used to attach the rudder bracing wires.



Aileron control cables (x 2):

Repeat the previous procedure to create an aileron control cable (0.12 mm diameter line), attached to one end of the turnbuckle.

Cut a long length of 0.12 mm diameter line.

Pass the line through the free 'eye' end of the turnbuckle.

Cut a short length of clear tube and slide it onto the line.

Loop the line back through the clear tube.

Slide the clear tube up to, **but not touching**, the 'eye' end of the turnbuckle.

Secure the lines in the clear tube using thin CA adhesive.

Pass the ends of the two lines, from each side, through the hole at the top of photo-etch part 2.

Tighten the lines to pull the clear tube up to, **but not** touching, the photo-etch part 2.

Secure the lines in the photo-etch part 2 using thin CA adhesive.

Cut away any residual tags of line.

Cut a long length of 0.08 mm diameter line.

Pass the line the through a blackened Brass tube.

Pass the line through the pre-drilled hole on the rear edge of photo-etch part 2.

Loop the line back through the blackened tube.

Slide the blackened tube up to, **but not touching**, the photo-etch part 2.

Secure the lines in the blackened tube using thin CA adhesive.

Cut away any residual tags of line at the tube end.



Elevator control cables:

Cut a long length of 0.08 mm diameter line.

Pass the line the through the hole in the top of photo-etch part 3.

Loop the line back and holding the photo-etch part 3, hold the two lines together and twist them together for 2 mm.

Secure the twists together using thin CA adhesive, then cut away the end tag on line.

However, as this lever and line will not really be visible, I chose not to use the lever and line on the model.



Painting (continued):

Brush paint the centre barrels of each of the pre-rigged turnbuckles with 'Tamiya' Bronze (X33) or similar.

Weathering (continued):

Brush paint a semi-matte clear coat, such as 'Tamiya' Semi-Gloss Clear or similar, mixed with 'Tamiya' Smoke (X19) over the windscreen, to 'dirty' the finish slightly.

NOTE: Refer to Part 2 (Weathering) of this build log. Avoid brushing on the acetate windscreen.

Apply weathering, as desired, to the outer and inner surfaces of the windscreen. I used 'Flory Models' Dark Dirt fine clay wash.

Assembly (continued):

Secure the landing gear into its locating holes on the underside of the fuselage, using CA adhesive. Make sure the locating rods in the struts fully locate into the fuselage holes with the top of the struts against the underside of the fuselage.

Secure the locating rods of the elevator into their pre-drilled holes in the trailing edge of the tailplane, using CA adhesive. Make sure the elevator is fully against the tailplane and angled down slightly (if desired) and is 90 degrees to the fuselage when viewed from above and horizontal when viewed from the front or rear.

NOTE: Test fit the two tailplane support struts before final fitting, as the struts are 'handed' and should only locate properly in their correct sides of the fuselage/tailplane.

Using CA adhesive, secure the locating rods of the two tailplane support struts into their pre-drilled holes in the lower, rear edges of the fuselage and in the forward, underside holes in the tailplane.

Using CA adhesive, secure the fin onto the protruding locating rods in the top, centre of the tailplane. Make sure the fin is fully against the tailplane and is vertical to the fuselage when viewed from the front or rear.

Using PVA adhesive, such as 'MicroScale' Micro Krystal Clear or similar, secure the windscreen assembly onto the fuselage, between the rear of the 'Vickers' machine gun and the cockpit surround padding. Make sure the bottom edges of the windscreen follows the contours of the fuselage.

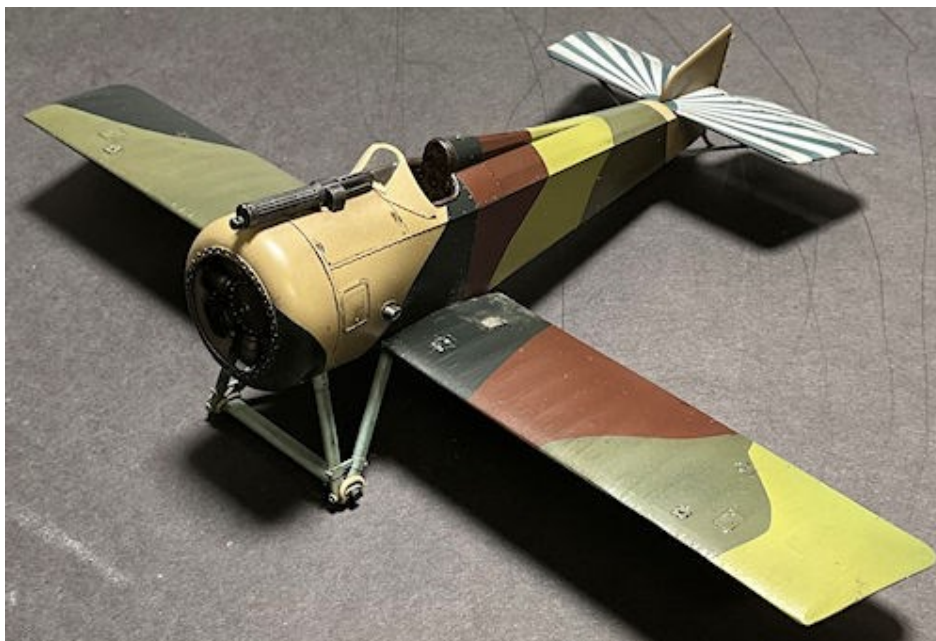

Insert the 0.5 mm diameter Brass locating rods into the pre-drilled holes at the fuselage end of the prepared 3D printed cabane strut assembly, leaving only approximately 1.5 mm of rod protruding from the inner edges.

Test fit the cabane struts assembly into its locating recesses in the top of the fuselage, inserting the locating rods into their pre-drilled holes. Make sure the four struts fully locate into their recesses.

Remove the cabane strut assembly, with changing the protruding rods.

Secure the locating rods into the struts using thin CA adhesive applied to the inner edges and protruding rods.

Snip away the excess rod protruding from the outer surfaces of the struts.

NOTE: *During the following step, limit removal of the protruding rods to prevent damaging the painted struts near the locating rods.*

Carefully file away the residual protruding rods from the outer surfaces of the struts to blend them to the surrounding surfaces.

Using thin CA adhesive, secure the cabane struts and their locating rods fully into their fuselage recesses.

Restore the worked areas of the struts by:

1. Brush painting with 'Tamiya' Light Blue (XF23) or similar to match the colour previously used.
2. Brush painting with a semi-matte clear coat, such as 'Tamiya' Semi-Gloss Clear (X35).
3. **NOTE:** *Refer to Part 2 (Weathering) of this build log.* Apply weathering to match the existing surfaces. I used 'Flory Models' Dark Dirt fine clay wash.

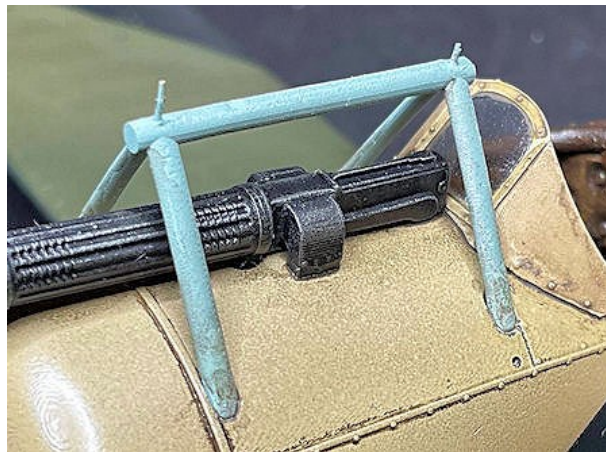

NOTE: *The pre-molded locating slots in the rudder and ailerons for the photo-etch control horns are too shallow to provide secure fitting.*

Using a sharp scraper, carefully scrape out the pre-molded slots in the rudder and ailerons to achieve a positive fit of their photo-etch control horns.

Using thin CA adhesive, secure the rudder control horns into their locating slots on both sides of the rudder. Make sure the pre-rigged lines are kept clear of the adhesive.

Using thin CA adhesive, secure the aileron control horns into their locating slots on the top, leading edge of the ailerons. Make sure the pre-rigged lines are kept clear of the adhesive.

Once the adhesive has fully set, brush paint the control horns with 'Tamiya' Rubber Black (XF85) or similar.

Pre-rigging (continued):

NOTE: Make sure that each prepared rigging line, when fitted, is more than long enough to reach its opposite end fixing point for when the upper wing is fitted.

Rudder:

NOTE: The rigging materials used are:

'Steelon' or 'Stroft GTM' Mono-Filament 0.08 mm diameter mono-filament line

'MFH' 0.4 mm diameter clear tube (P-957)

Blackened 0.4 mm diameter Brass tube, such as 'Albion Alloy's MBT04 or similar.

Cut a long length of the line

Cut two short lengths of the clear tube.

Cut two short lengths of the blackened Brass tube.

Slide a clear tube onto the line.

Pass the line through the pre-drilled hole in the rear edge of a rudder control horn.

Loop the line back and through the clear tube.

Slide the clear tube up to the control horn.

Secure the line in the clear tube using thin CA adhesive.

Cut away any residual tag of line at the end of the clear tube.

Slide a blackened Brass tube onto the line.

Pass the free end of the line through the hole in the photo-etch on the trailing edge of the rudder.

Slide a blackened Brass tube onto the line.

Slide a clear tube onto the line.

Pass the line through the pre-drilled hole in the rear edge of the remaining rudder control horn.

Loop the line back and through the clear tube.

Slide the clear tube up to the control horn.

Keeping the line taut, secure the line in the clear tube using thin CA adhesive.

Cut away any residual tag of line at the end of the clear tube.

Slide the two blackened Brass tubes to the trailing edge of the rudder.

Secure the blackened Brass tubes to the lines using thin CA adhesive.



at

Ailerons:

NOTE: *The following procedure applies to both ailerons. The rigging materials used are:*

'Steelon' or 'Stroft GTM' Mono-Filament 0.08 mm diameter mono-filament line

Blackened 0.4 mm diameter Brass tube, such as 'Albion Alloy's MBT04 or similar.

Cut a long length of the line

Cut two short lengths of the blackened Brass tube.

Slide a tube onto the line.

Pass the line through the pre-drilled hole in the rear edge of the aileron control horn.

Loop the line back and through the tube.

Slide the tube up to the control horn.

Secure the line in the tube using thin CA adhesive.

Cut away any residual tag of line at the end of the tube.

Pass the free end of the line rearwards and through the hole in the photo-etch on the trailing edge of the aileron.

Slide a tube onto the line.

Pass the line through the hole in the Anchor Point, previously fitted in the underside of the aileron.

Loop the line back and through the tube.

Slide the tube up to the Anchor Point.

Keeping the line taut, secure the line in the tube using thin CA adhesive.

Cut away any residual tag of line at the end of the tube.



Top surface of the lower wings:

NOTE: *The following procedure applies to both lower wings and uses the pre-rigged lines that were created earlier. Make sure that each prepared rigging line, when fitted, is more than long enough to reach its opposite end fixing point for when the upper wing is fitted.*

Using thin CA adhesive, secure the One Ended turnbuckles on the pre-rigged landing wires, into their pre-drilled locating holes in the top surface of the lower wings. The locating holes are inboard from the locating plates for the interplane struts. Make sure the lines and turnbuckles, when fitted, will be aligned and straight to the top of the fitted front and rear fuselage cabane struts.

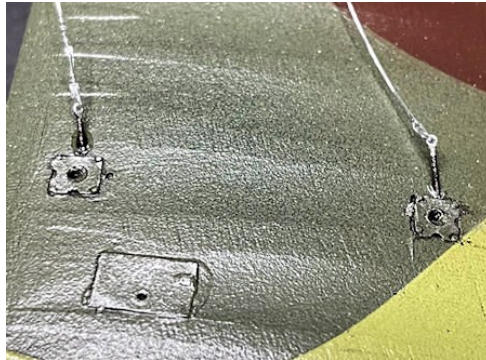

Using thin CA adhesive, secure the One Ended turnbuckles on the pre-rigged incidence wires, into their pre-drilled locating holes in the top surface of the lower wings. The locating holes are between the front and rear interplane struts. Make sure the lines and turnbuckles, when fitted, will be aligned and diagonally straight to the top of the opposite interplane strut.



NOTE: *The following procedure applies to both lower wings. The rigging material used is 'Steelon' or 'Stroft GTM' Mono-Filament 0.08 mm diameter mono-filament line.*

Cut a long length of the line.

Using thin CA adhesive, secure one end of the line into the pre-drilled locating hole in the photo-etch inspection plate, located outboard from the forward interplane strut.



Assembly (continued):

Rudder:

NOTE: *During the following steps, make sure the pre-rigged lines are kept clear of the adhesive.*

Using thin CA adhesive, secure the rudder into the pre-drilled holes in the rear edge of the fin.



Ailerons:

Using thin CA adhesive, secure the two ailerons into their pre-drilled holes in the rear edge of the upper wing halves. Remember to angle them slightly in opposition, if desired.

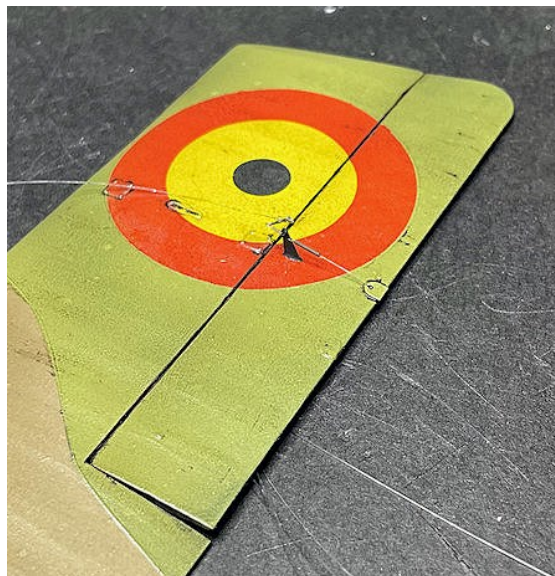

Upper wing:

NOTE: *When fitting the upper wing, take note of the positioning and angles of the interplane struts and the 3 degree dihedral angle of the upper wing. In order to have time to locate and align the upper wing onto the interplane and fuselage struts, I used a slow setting CA adhesive ('VMS*

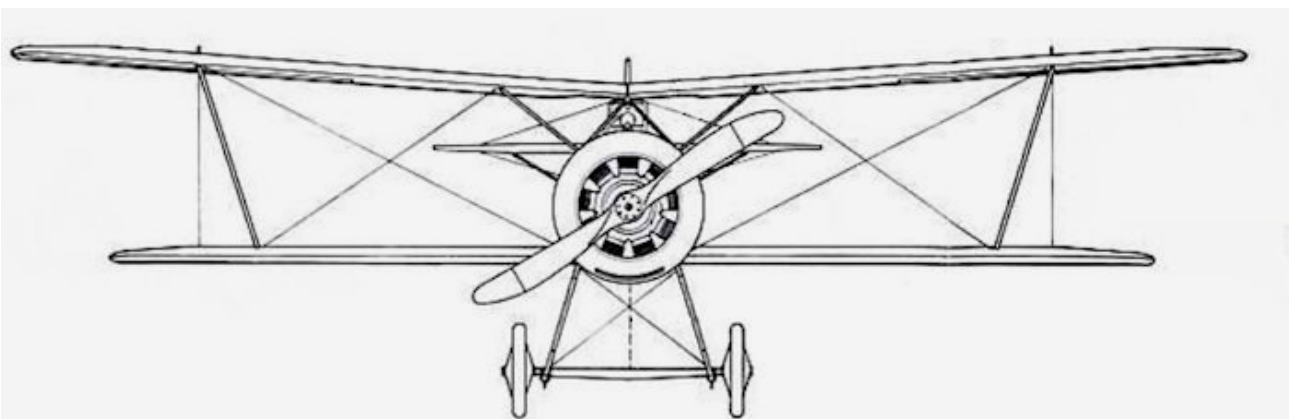

Use masking tape to hold the pre-rigged lines onto the upper wing and clear of the interplane strut locating holes.

Check the 3 degree dihedral angle of the upper wing and if necessary, slightly bend the joined wings upwards to achieve the dihedral angle.

Locate the two upper wing halves together leaving a slight gap at the centre join.

NOTE: Refer to the previous illustrations for strut positioning and angles.

Use the CA adhesive to fully locate the four interplane struts into their pre-drilled locating holes in the top surface of the lower wing. Angle the struts to approximate their final positions.

Apply CA adhesive along the top bar of the fuselage cabane strut assembly, as this will help securing the upper wing in position.

Position the upper wing onto the top of the cabane strut assembly and push the two halves of the wing together.

Locate the rods in the top of the four interplane struts fully into their locating holes in the underside of the upper wing.

If necessary hold the upper and lower wings together using elastic bands, which helps to keep the struts located.

Check the positioning and alignment of the upper and lower wings when viewed from above and from the sides.

Check that the four interplane struts are angled correctly and are aligned.

Apply 'thin' CA adhesive to secure the interplane struts into their locating holes in the underside of the upper wing.

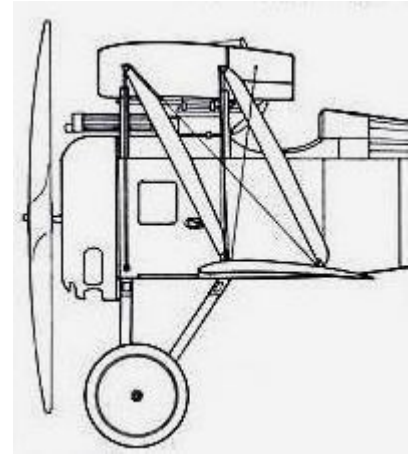

NOTE: I found it easier to fit the for cabane side support struts after the upper wing was fitted and stable. Do not apply too much pressure on these struts as being 3D printed and resin, they are brittle and can easily be broken.

Test fit the four side support struts into their pre-drilled locating holes in the fuselage and underside of the upper wing. Slight bending may be required to locate the end rods in the struts.

NOTE: Previously, when test fitting the upper wing, I found that the kit supplied 3D printed cabane side support struts were too short and when located, were approximately 1.0 mm clear of the fuselage. Therefore, I modified the fuselage cabane strut assembly to lower the upper wing slightly to allow the struts to locate fully. Now, with the upper wing fitted, I found that the struts were still too short. Therefore, I decide to discard the kit supplied struts and create replacement struts from 1.2 mm diameter Brass tube, formed into an airfoil profile and with internal 0.3 mm diameter Brass rod for locating the struts into their pre-drilled holes in the fuselage and upper wing.

The ends of the replacement cabane side support struts were filed until each located fully in their positions. The internal rods were then added and their protruding ends bent to fit the locating holes. The struts were secured in position using thin CA adhesive.

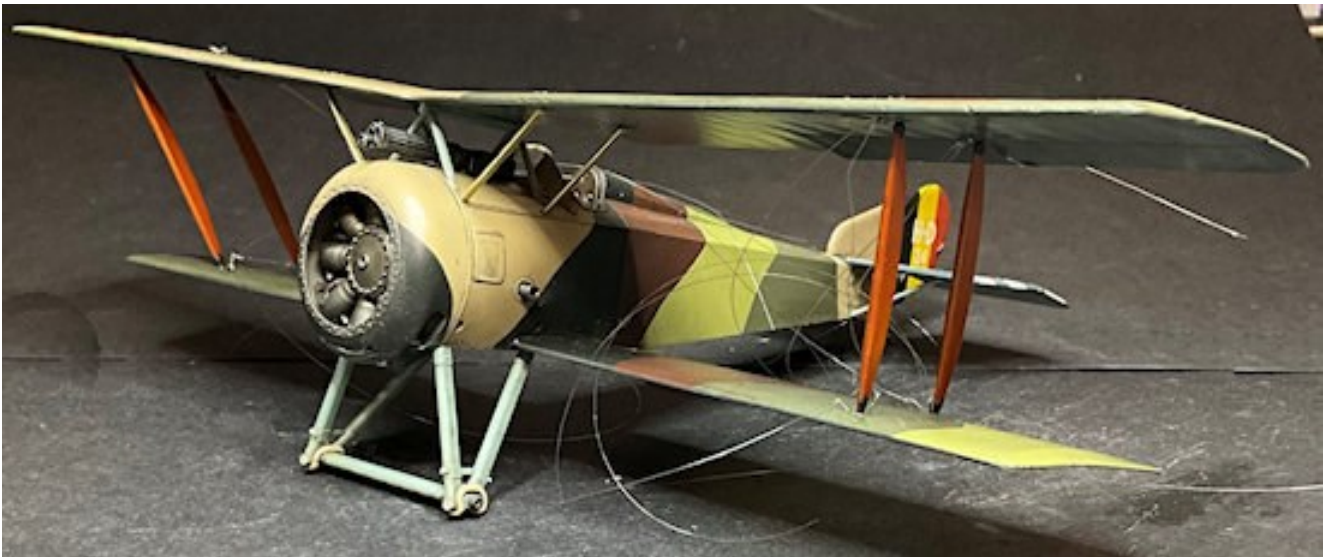

The struts were then brush primed with 'Tamiya' Grey (XF80) then painted with Light Blue (XF23). Finally a light coat of weathering ('Flory Models' Dark Dirt fine clay wash was applied.

Final rigging:

NOTE: The following procedure applies to both upper wing halves. Make sure that when a line is required to be cut, each line is more than long enough to reach its opposite end fixing point. The rigging materials used are:

'Steelon' or 'Stroft GTM' Mono-Filament 0.12 mm diameter mono-filament line.

Blackened 0.4 mm diameter Brass tube, such as 'Albion Alloy's' MBT04) or similar.

'MFH' 0.4 mm diameter clear tube (P-957).

Twin flying wires:

Cut a long length of the line.

Using thin CA adhesive, secure one end of the line into a flying wire pre-drilled hole in the bottom edge of the fuselage.

Repeat to attached a flying wire to the remaining seven flying wire pre-drilled holes.

Cut a short length of the clear tube.

Cut two short lengths of the blackened tube.

Slide the two blackened tubes onto the line.

Slide the clear tube onto the line.

Pass the free end of the line diagonally up and across to its previously fitted Anchor Point, inboard from the locating plate for the interplane strut, in the underside of that upper wing half.

Pass the line through the Anchor Point then loop the line back and through the clear tube.

Keeping the taut, slide the tube up to the Anchor Point.

Secure the line in the tube using thin CA adhesive.

Cut away any residual tag of line at the end of the tube.

Slide the each of the two blackened tubes to their end of the line and secure in position using thin CA adhesive.

Repeat the procedure to rig the remaining seven flying wires.

Landing wires:

Cut a short length of the clear tube.

Slide the clear tube onto a pre-rigged landing wire on a lower wing.

Pass the free end of the line diagonally up and across to its previously fitted Anchor Point, outboard from its cabane side support strut on the underside of that upper wing half.

Pass the line through the Anchor Point then loop the line back and through the clear tube.

Keeping the line taut, slide the tube up to the Anchor Point.

Secure the line in the tube using thin CA adhesive.

Cut away any residual tag of line at the end of the tube.

Repeat the procedure to rig the remaining three landing wires.

Incidence wires:

Cut a short length of the clear tube.

Slide the clear tube onto a pre-rigged incidence wire at the interplane struts on the lower wing.

Pass the free end of the line diagonally up and across to its previously fitted Anchor Point, at the opposite interplane strut, on the underside of that upper wing half.

Pass the line through the Anchor Point then loop the line back and through the clear tube.

Keeping the line taut, slide the tube up to the Anchor Point.

Secure the line in the tube using thin CA adhesive.

Cut away any residual tag of line at the end of the tube.

Repeat the procedure to rig the remaining seven incidence wires.

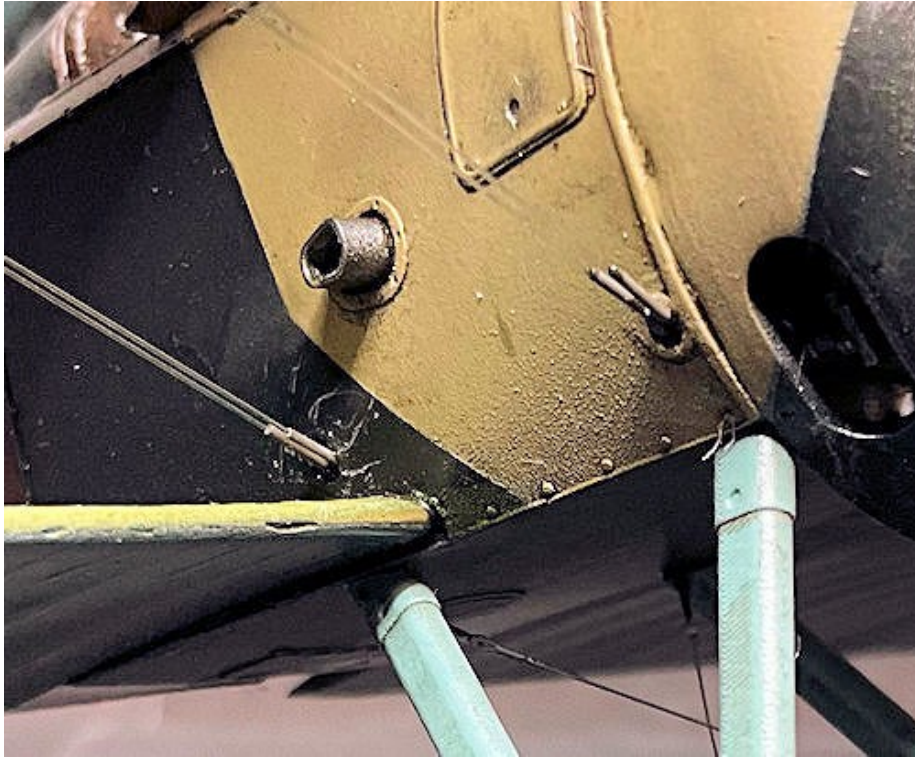

Aileron control cables:

NOTE: *The following procedure applies to both ailerons and the lower wings. The rigging materials used are:*

'Steelon' or 'Stroft GTM' Mono-Filament 0.08 mm diameter mono-filament line.

Blackened 0.4 mm diameter Brass tube, such as 'Albion Alloy's' MBT04) or similar.

'MFH' 0.4 mm diameter clear tube (P-957).

Cut a short length of the blackened tube.

Slide the blackened tube onto the line.

Slide the tube onto the aileron control line previously attached to the lower wing.

Pass the free end of the line up and rearwards to the previously fitted and already pre-rigged Anchor Point in the underside of the aileron.

Pass the line through the Anchor Point then loop the line back and through the tube.

Keeping the taut, slide the tube up to the Anchor Point.

Secure the line in the tube using thin CA adhesive.

Cut away any residual tag of line at the end of the tube.

Repeat the procedure to attach the control line to the opposite aileron.

Trim the length of the control line attached to the forward edge an aileron control horn on the top of an aileron. The length should be such that when held taut, the line can be fully inserted into the pre-drilled hole in the top surface of the upper wing (inside the added photo-etch slot surround).

Holding the line taut, secure the end of the line into the pre-drilled hole.

Repeat to attach the control line oat the opposite aileron.

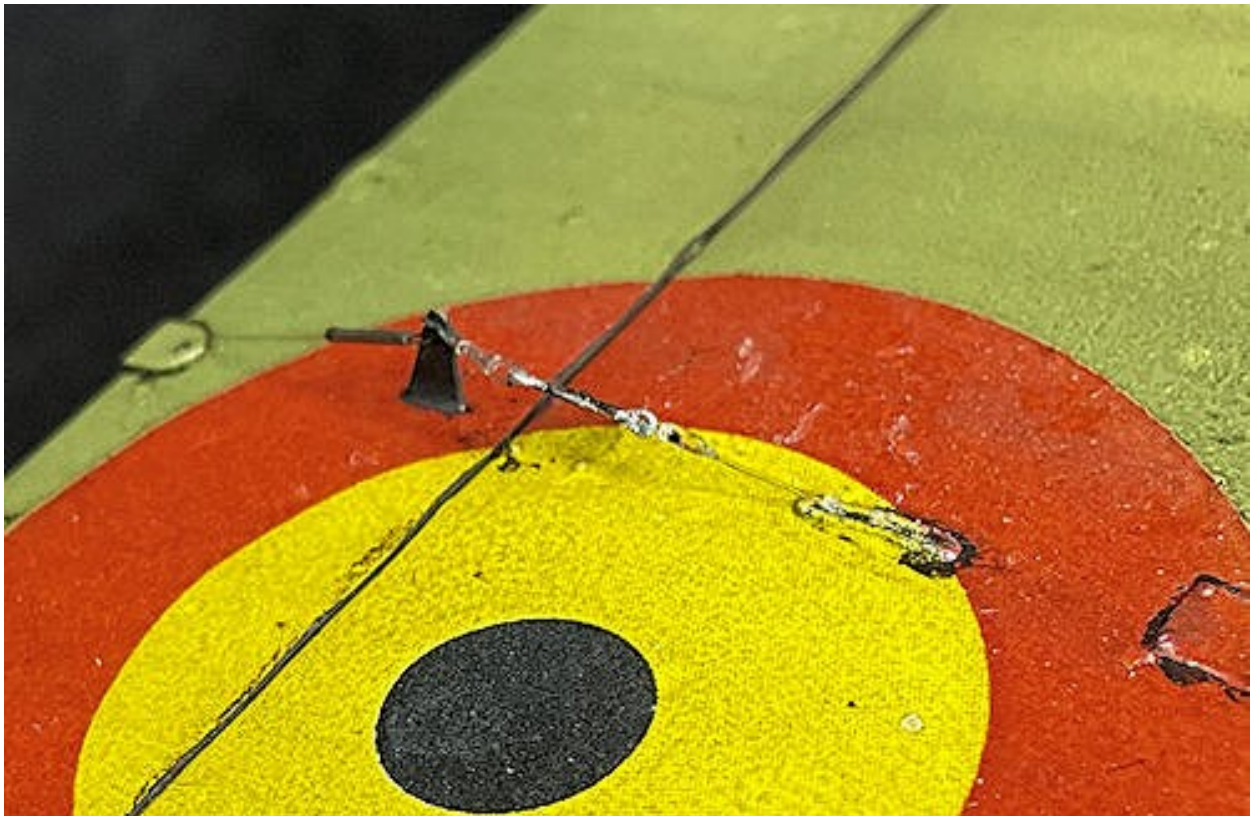

Landing gear bracing wires:

NOTE: *The rigging materials used are:*

'Steelon' or 'Stroft GTM' Mono-Filament 0.08 mm diameter mono-filament line.

'MFH' 0.4 mm diameter clear tube (P-957).

Cut a length of the line.

Cut a short length of the tube.

Pass the line through the free 'eye' end of the 'Gaspatch' Type C turnbuckle on the pre-rigged bracing wire.

Pass both ends of the line through the pre-drilled hole (from the inside) in the top of a landing gear rear strut.

Pass the free end of the bracing wire diagonally down and across to the pre-drilled hole at the bottom of the opposite struts, forward from the axle fairing.

Pass the line through the hole.

Hold the lines at both ends to keep the line taut and secure the lines into the struts using thin CA adhesive.

Cut away any residual tags of line from the outer edges of the struts.

Cut a short length of the tube.

Slide the tube onto the free end of a line pre-rigged on the axle bracing wire.

Pass the line through the 'eye' of one of the Anchor Points already fitted in the forward, ends of the axle fairing.

Loop the line back and through the tube.

Repeat to attach the other turnbuckle line to the opposite Anchor Point.

Keeping the taut, slide the tube up to the Anchor Point.

Position the Type C turnbuckle centrally at the front of the axle fairing.

Hold the lines at both ends to keep the lines taut and secure the lines into the tubes using thin CA adhesive.

Cut away any residual tags of line from the end of the tubes.

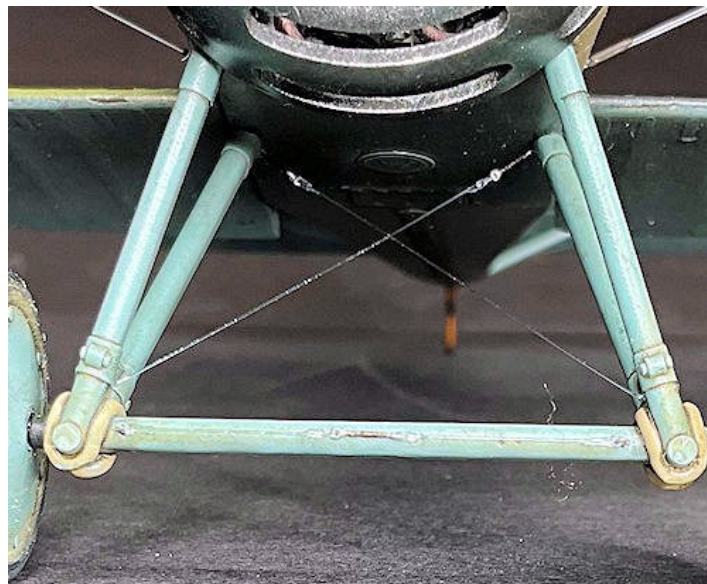

Rudder control cables:

Insert the two rudder control cables into their locating slots on both sides of the fuselage.

Keeping the lines taut and as far as possible vertically separated, secure them into their locating slot using thin CA adhesive.

Fin bracing wires:

NOTE: *The rigging materials used are:*

'Steelon' or 'Stroft GTM' Mono-Filament 0.12 mm diameter mono-filament line.

Blackened 0.4 mm diameter Brass tube, such as 'Albion Alloy's' MBT04) or similar.

Cut a very long length of line.

Cut four short lengths of tube.

Pass the line through the pre-drilled hole in the upper, trailing edge of the fin

Slide two tubes onto each side of the line.

Pass the ends of the line down and through the pre-drilled holes in the outer, trailing edge of the tailplane.

Slide two tubes onto each side of the line.

Pass the ends of the line through the pre-drilled hole in the towards the bottom of the rudder post.

Apply tension (using grip tweezers or similar) to both ends of the line to keep the line taut.

Using thin CA adhesive, secure the line into the holes in the fin, tailplane and rudder post.

Slide the tubes up to the surface of the tailplane and secure in place using thin CA adhesive.

Cut away any residual tend tags of line at the rudder post.



Assembly (continued):

Fuselage grab handles:

NOTE: *I chose to not use the kit supplied photo-etch grab handles for the bottom edge of the fuselage rear. Instead, I made replacements from rod.*

Using as guides the two pre-molded recesses in both sides of the bottom edge of the fuselage rear, drill holes of 0.3 mm diameter up and through the fuselage.

Using 0.3 mm diameter Brass rod, such as 'Albion Alloy's' or similar, cut and bend into shape two grab handles.

Insert the ends of the grab handles into the drilled holes then bend the handles down inline with the fuselage sides.

Brush paint the handles with 'Tamiya' NATO Black (XF69) or similar.



Upper wing 'funnel':

The kit supplies an air 'funnel', which is intended to represent the funnel used on aircraft fitted with the 'Badin' fuel system. However, it's not know what fuel system was fitted to the Hanriot HD.1 flown by Willy Coppens and photographs of his aircraft do not show this funnel as being fitted. **Therefore, I chose not to use this part.**

Propeller:

NOTE: *For this model I have the mechanic figure turning the propeller. Therefore, I positioned the propeller accordingly.*

Using CA adhesive, secure the propeller, in the desired position, into its locating hole in the engine.

Decals (continued):

Apply the 'Thistle' decals to the fuselage sides.

Apply the small white 'lever ici' (lift here) decals to the lower edge of the fuselage sides, above the added grab handles.

Weathering (continued):

NOTE: *If necessary, apply weathering over the applied fuselage decals to blend them with the existing surface finish of the fuselage. Refer to Part 2 (Weathering) of this build log.*

Lightly airbrush a semi-matte clear coat, such as 'Alclad' Light Sheen (ALC-311) or similar, over the applied decals. This will provide a good base for applying weathering.

Apply weathering over the applied fuselage decals to blend with the surrounding surfaces. I used 'Flory Models' Dark Dirt fine clay wash.

To seal and protect, lightly airbrush a semi-matte clear coat, such as 'Alclad' Light Sheen (ALC-311) or similar, over the applied decals.



PART 12

FIGURES

PART 12 - FIGURES

The figures I chose to use are the 'Copper State Models' French mechanic (F32-046) and the 'Kellerkind' U.S.A.A.S pilot (54-051).

NOTE: *The figures are made of resin (refer to Part 5 [Resin] of this build log).*

Pilot:

Preparation:

Remove the figure and combined arms from their moulding blocks.

File or sand away residual mounting block resin from the parts.

Check that there are no surface imperfections and if necessary, fill and/or sand to restore the surface finish.

Assembly:

Using CA adhesive, secure the two arms onto the figure.

Painting:

NOTE: *The figure was painted using 'AK Interactive' and 'Tamiya' acrylic paints. Thin the 'AK' paints with their acrylic thinners (AK712).*

Airbrush the figure parts with a grey primer, such as 'AK Interactive' Grey (AK-758) or similar.

Gaiters - 'Tamiya' Semi-Gloss (X18), 'AK Interactive' Brown Leather (AK3031). Lacing studs Buttons 'Mr. Colour' Stainless Steel (213).

Shoes - 'Tamiya Flat Brown (XF10).

Trousers/Jacket Collar - 'Tamiya' Olive Green (XF58) with J.A. Green (XF13) shadows.

Flying coat - 'AK Interactive' Brown Leather (AK3031), British Uniform (AK3081) shadows, British Uniform Light (AK3082) highlights. Buttons 'Mr. Colour' Stainless Steel (213). Belt buckle 'Mr' Colour' Brass (219).

Wool hat - 'Tamiya' Deck Tan (XF55).

Glove in pocket - 'Tamiya' Buff (XF57).

Goggles - 'Tamiya' Buff (XF57) with Flat Brown (XF10) highlights. Lenses 'Mr. Colour' Stainless Steel (213) and Tamiya' Semi Gloss Clear (X35). Strap 'Humbrol' Leather (62)

Flesh - 'Citadel Colour' Cadian Flesh Tone with Kislev Flesh highlights.

Weathering:

Weather the flying coat and gaiters by airbrushing 'Alclad' Light Sheen (ALC311 mixed with 30% 'Tamiya' Smoke (X19).

Lightly sponge 'Tamiya' Weathering Master Set A (Mud) over the shoes.

Lightly sponge 'Tamiya' Weathering Master Set D (Oil Stain) over the pockets and elbows of the flying coat and wool hat.

Brush 'AK Interactive' Kerosene wash (AK2039) down the laces of the gaiters.



Mechanic:

Modification:

NOTE: *The feet of the mechanic figure are angled as the intention is for the figure to be stood on the wheel of an aircraft working on the fuselage. However, I wanted the figure to be stood on the ground. Therefore, I needed to modify the figure accordingly.*

I cut both shoes away from the legs of the figure.

The tops cut faces on the legs and shoes were filed flat to allow both shoes to be attached to the legs and be correctly seated on the ground.

I drilled holes of 0.8mm diameter up through the shoes and into the legs of the figure.

Two lengths of 0.8 mm diameter Brass rod were cut from such as 'Albion Alloy's or similar.

The rods ere inserted through the holes in the shoes and up into the holes in the legs.

The shoes were then positioned and secured to the rods and the legs using thin CA adhesive.

The rod under one shoe was cut away leaving the other leg rod protruding. This rod will be used to hold the figure for painting and for mounting the figure to the display base.

Check that there are no surface imperfections and gaps. If necessary, fill and/or sand to restore the surface finish.

Assembly:

Using CA adhesive, secure the two arms onto the figure.

NOTE: *The supplied head for the figure was discarded and a suitable resin cast head from 'Hornet' was used instead.*

Secure the head onto the body of the figure using thin CA adhesive.

Modification (continued):

NOTE: *For this model I have the mechanic figure turning the propeller. Therefore, I modified the figure accordingly.*

Cut off the left hand at the coat sleeve.

Drill a hole of 0.3 mm diameter up into the sleeve of the left arm.

Drill a hole of 0.3 mm diameter into the wrist of the left hand.

Cut a length of 0.3 mm diameter Brass rod, such as that from 'Albion Alloy's' or similar.

Secure the rod into the hole in the left arm, using thin CA adhesive.

Locate the left hand onto the protruding rod and trim the length of the rod to enable the hand to contact the arm.

Carefully bend the rod with the hand located to achieve the desired position for the hand.

Secure the hand onto the rod using CA adhesive.

Before the adhesive sets, check for the correct positioning of the hand.

If necessary, fill the exposed rod with CA adhesive to reproduce the wrist.

Painting:

NOTE: *The figure was painted using 'AK Interactive' and 'Tamiya' acrylic paints. Thin the 'AK' paints with their acrylic thinners (AK712).*

Airbrush the figure parts with a grey primer, such as 'AK Interactive' Grey (AK-758) or similar.

Shoes - 'Tamiya Flat Brown (XF10).

Trousers - 'AK Interactive' German Uniform Base (AK3091) with British Uniform Shadow (AK3083) shadows.

Jacket - 'AK Interactive' British Uniform (AK3081), Brown Leather (AK3031) shadows, British Uniform Light (AK3082) highlights.

Buttons - 'Mr. Colour' Stainless Steel (213).

Flesh - 'Citadel Colour' Cadian Flesh Tone with Kislev Flesh highlights.

Hair - 'Tamiya' Royal Light Grey (XF80).

Weathering:

Weather the jacket by airbrushing 'Alclad' Light Sheen (ALC311 mixed with 30% 'Tamiya' Smoke (X19).

Lightly sponge 'Tamiya' Weathering Master Set A (Mud) over the shoes.

Lightly sponge 'Tamiya' Weathering Master Set D (Oil Stain) over the pockets and elbows of the jacket and trousers. Also lightly over the hair.

NOTE: *Refer to Part 2 (Weathering) of this build log.*

Apply weathering, as desired, as shadows on the trousers. I used 'Flory Models' Dark Dirt fine clay wash.



PART 13

DISPLAY BASE

PART 13 - DISPLAY BASE

The display case is made from piano black and clear acrylic sheet of 3mm thickness. The base shoulder, for locating the clear cover, is a second thickness on top of the base plate. This case was purpose built by Paul Moss, who has a retail outlet on Ebay - www.inperspective.com

The grass mat used was the 'Polak' Wild Meadow variant E (4705).

The information plaque was engraved by 'TLS Engraving Ltd'.

Grass mat:



The grass mat was cut to the desired shape. The clear plastic backing was removed from the grass mat, which was then positioned on the base. The mat was laid onto the display base and positioned to ensure the model would clear the display top when located. A soft pencil was used to lightly trace the outline of the mat on the display base. PVA adhesive was then applied to the backing (underside) of the mat, which was then laid back onto the base, aligned to the pencil outline and gently pushed down to make proper contact. The grass mat was covered with a sheet of kitchen 'Cling Film' and several heavy books were then stacked onto the cling film, to press the grass mat fully in contact with the display base. The books and cling film were removed after two hours, when the edges of the grass mat were checked for contact (apply PVA adhesive if not). The grass tufts were gently brushed to remove any flatness.

Aircraft model:

The aircraft was not fixed to the display base, but left as 'free standing'. Although this may not be as secure as fixing the model to the display base, it does mean the model will not be subjected to shock loading when being moved around, as it might be if fixed on the display

The figure:

The figures were positioned on the base in their final positions and the location of the pin in the legs of the figures were marked on the grass mat. Holes of 1.0 mm were drilled through the grass mat and into (not through) the base. PVA adhesive was then applied to the pins of the figures, which were then carefully seated into the drilled hole. Light pressure was applied to the figures to ensure they were fully located in the base.

PART 14
COMPLETED
MODEL
PHOTOGRAPHS



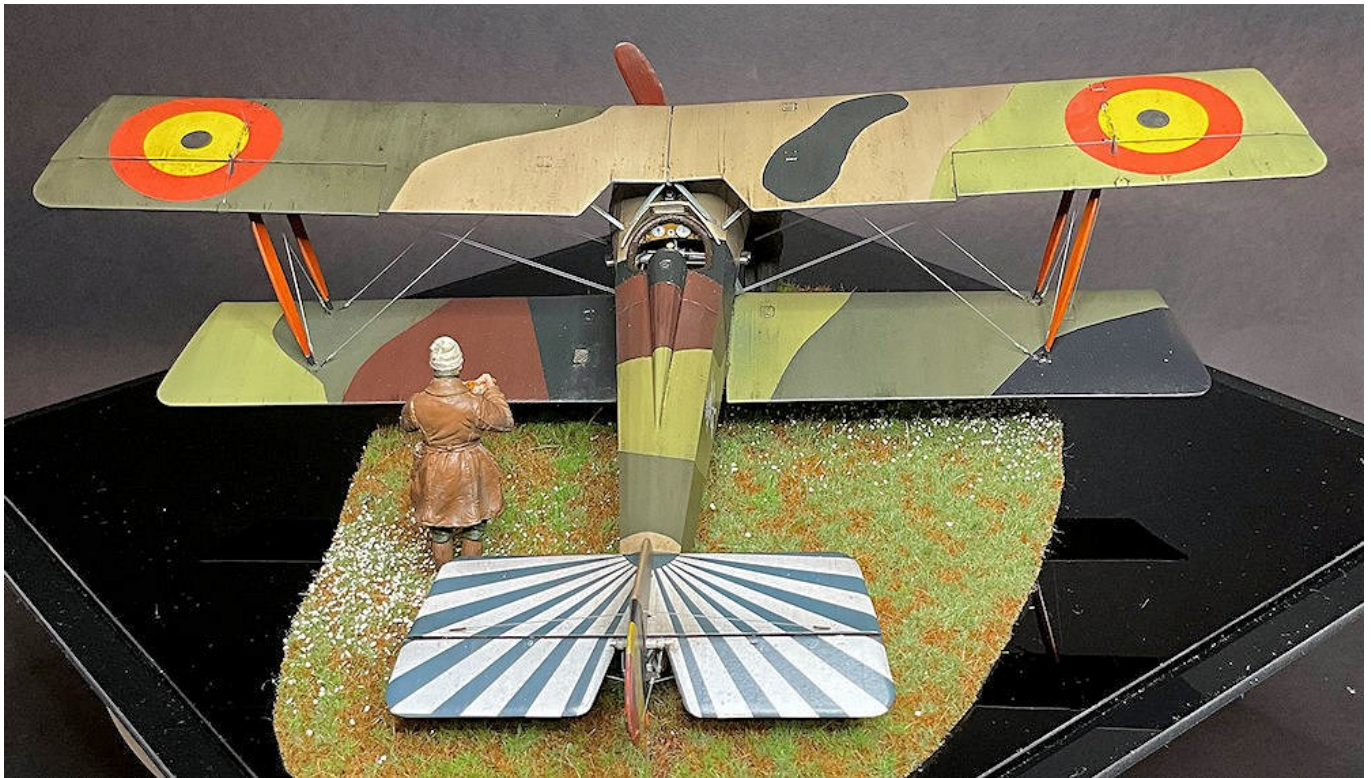
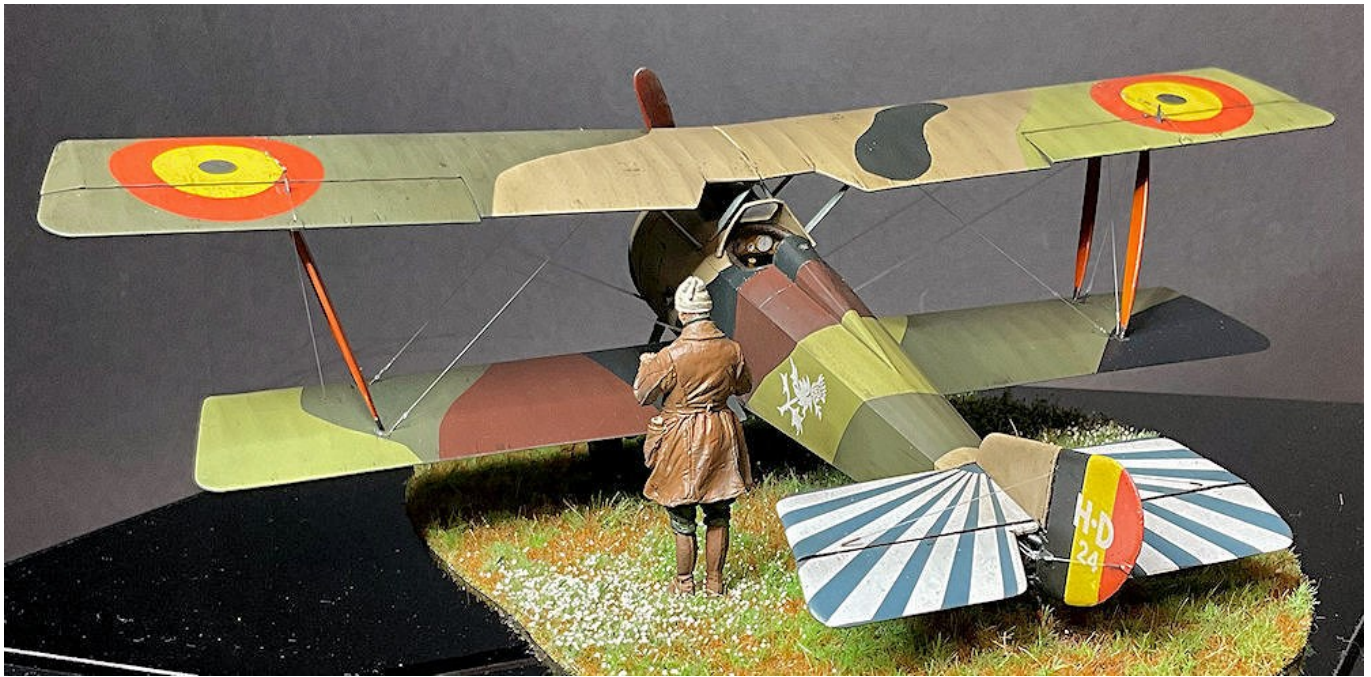





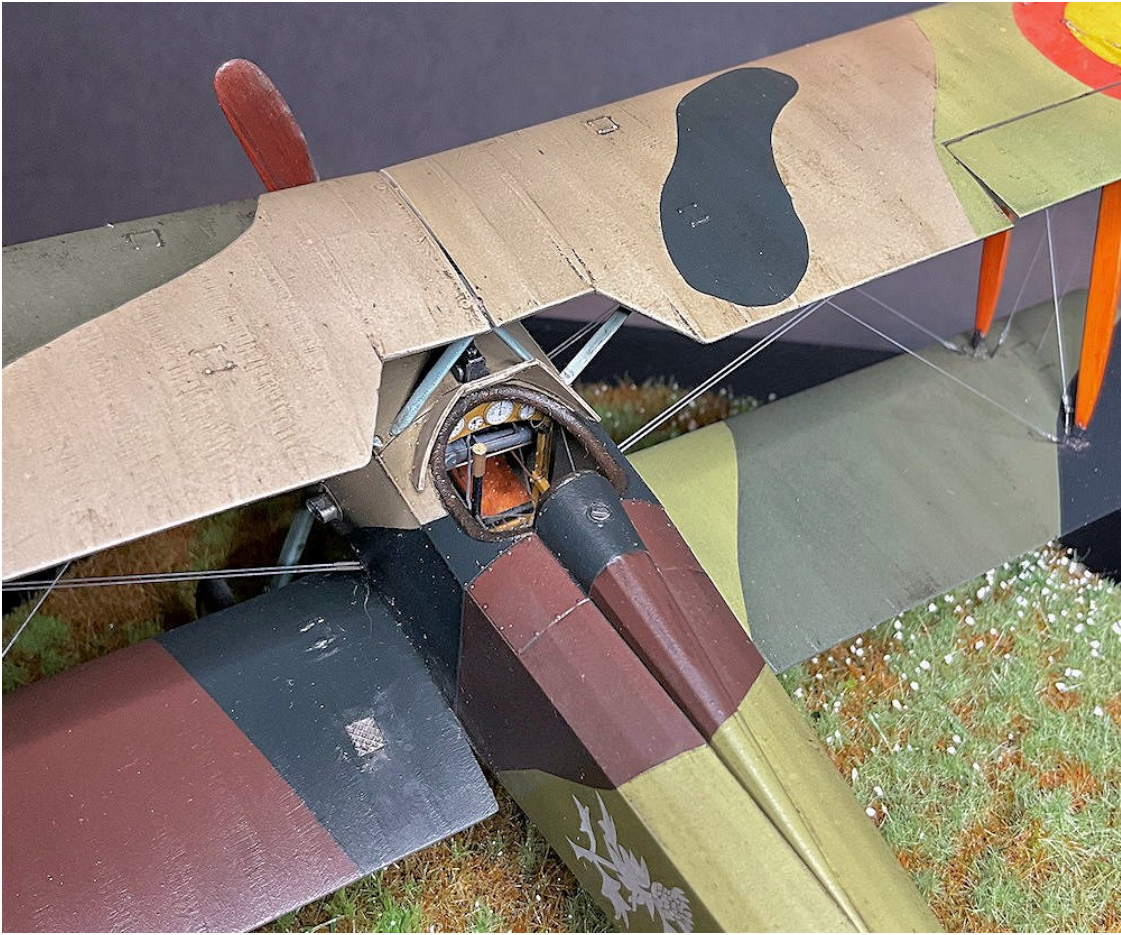

END