

Fokker E.V 'Razor Wing'

World War One Aircraft Models

I have always held a fascination with early military aircraft. After serving for 27 years in the Royal Air Force, I became a Military Aerospace Technical Author. Although, as most modelers, I got involved in the world of construction kits at an early age, I stopped for most of my service career and for some years afterwards.

I started modeling again a few years ago and now enjoy the challenge of building 1:32 scale models of aircraft from World War One. Since posting photographs of my completed models online, people have asked if I would create a 'build log' for future builds.

I don't consider myself a 'master' of this craft, but hope to be able to pass on what I have learned. As such, here is my build log, which is for the Fokker E .V 'Razor' aircraft, from MicroMir Models.

Mike 'Sandbagger' Norris

sandbaggeruk@sky.com

Completed: January 2018

CONTENTS

INTRODUCTION

AFTER MARKET

PREFACE

The pilot

The Aircraft

PART 1 - THE MODEL - Modifications or Corrections:

General surfaces

Rigging points

Engine

Engine cowl

Propeller

Stacking Pads

Gun blast plates

Carburettor air intakes

Aileron animation

Tailplane

Wing support struts

Undercarriage support struts

Pilot step and grab handles

Ammunition containers access panel

Cockpit detail:

Compass/Foot plates

Cockpit frames and gun support cross bar

Controls

Seat/seat frame/seat belts

Compass deviation chart

Back screen

Fuel/oil tank

Ammunition containers (tanks)

Gun support bar

PART 2 - THE COCKPIT

PART 3 - FUSELAGE INTERNALS

PART 4 - THE ENGINE

PART 5 - WHEELS

PART 6 - WEAPONS

PART 7 - PROPELLER

PART 8 - DECALS

PART 9 - RIGGING (General)

PART 10 - CONSTRUCTION

PART 11 - FIGURES

PART 12 - DISPLAY BASE

COMPLETED MODEL PHOTOGRAPHS

INTRODUCTION

Before I start with the build log, I'd like to show how I've set up my work area. I prefer to keep the work area as clear as I can (I've lost too many small items in the past). I think it's important to have the tools etc you need ready to hand and other, non-essential stuff tucked out of the way until needed. I'm lucky in that I have my 'man cave', which is sorted into a modelling area, airbrush spray booth in addition to my work station PC, games PC and games console.

Sorted



AFTER MARKET

Pilot Figure

Standing German Airman - Copper State Figure (F32-040)

Engine

Roden 1:32 scale Oberursel Ur.II rotary (ROD624).

Weapons

GasPatch 1:32 scale Spandau 08/15 machine guns (14-32061).

Seat

'Aviatic' Fokker Seat (ATTRES 022).

Decals

Aviatic (ATT32115) 1:32 scale Fokker D.V/D.VIII 4 colour lozenge decals.

Pheon Fokker E.V Volume 2 (32062),

Airscale Dial Decals (Generic World War 1) (AS32 WW1)

Photo-Etch (PE)

JadarHobby Shop - Part No.32028 Fokker DR.1 (1/32)

JadarHobby Shop - Part No.48087 (1/48),

Airscale Instrument Bezels (PE32 BEZ)

Rigging accessories

GasPatch Elite Accessories Turnbuckles 1/48 scale (12-48009)

Albion Alloy Micro-tube and Rod (Brass or Nickel Silver - various diameters),

'Steelon' Mono-Filament 0.12 mm diameter.

Sundries

Taurus Models - Fokker Cowl Nuts (D3224), Wingnuts (MC0025), Microscale's 'MicroSet/Sol',
Paints (Tamiya Acrylic, Humbrol Acrylic, Mr Metal, MRP Acrylic Lacquer, Alclad Lacquers,
Mr. Colour Levelling Thinners, PVA Adhesive, Cyanoacrylate (CA) glue (thin), BlueTack,
Vallejo Plastic Putty, sanding and polishing sticks from 'Flory Models'.

Weathering mediums

'Flory Models' clay washes and pigments, AK Interactive engine washes,
Tamiya Weathering Master sets.

Display Base

Model Scene Grass Mats, purpose built Acrylic base and cover, etched plaque (name plate).

PREFACE

The pilot:

References:

1. Osprey Aircraft of the Aces - Naval Aces of WW1 (Part 2) by Jon Guttman.
2. Windsock Data File 25 - Fokker D.VII by P. M. Grosz.
3. 'Pheon' Decals - 32062 Fokker E.V (Volume 2).
4. The 'Vintage Aviation' web site:
[http://thevintageaviator.co.nz/projects/aircraft/Fokker-dviii/detail/walk around](http://thevintageaviator.co.nz/projects/aircraft/Fokker-dviii/detail/walk%20around)
5. The 'Engels E6' web site:
http://www.collectors-edition.de/f-t-s_zeichnungen_FokkerDVIII_english.htm

This aircraft was piloted by Vizeflugmeister Hans Goerth of Marine Feld Jasta III (MJF III). He scored seven victories whilst flying with MJF III, none of which when flying this aircraft. Initially he flew with Kusta III before moving to MJF 1 on the 26th February 1918. On the 21st June 1918 he was transferred to MJF III, which was formed in that month. Here he remained until the end of the war and with 7 victories, was the leading ace of MJF III.

His victories were as follows:

1. Airco DH.4 (Ser No. A8013) on the 30 June 1918 (Albatross D.Va).
2. Airco DH.9 from No.206 Squadron on the 7 July 1918 (Albatross D.Va)
3. Airco DH.4 of No.202 Squadron on the 16 July 1918 (presumed Albatross D.Va).
4. Sopwith Camel of No.65 Squadron on the 30 August 1918 (Fokker D.VII).
5. Sopwith Camel of No.210 Squadron on the 16 September 1918 (presumed Fokker D.VII)
6. DH.9 of No.108 Squadron on the 1 October 1918 (Fokker D.VII)
7. Sopwith Camel of No.210 Squadron on the 1 October 1918 (Fokker D.VII).

After the war, in January 1919, Goerth joined the 'Kampfgeschwader Sachsenberg', a volunteer unit commanded by the ace Gotthard Sachsenberg. This unit was engaged in actions against the Russian Communists of the Red Army, operating in the Baltic States. The unit was withdraw from operations in December 1919. The date of Goerth's birth and death could not be found.



The aircraft:

References:

1. Osprey Aircraft of the Aces - Naval Aces of WW1 (Part 2) by Jon Guttman.
2. 'Pheon' Decals—32062 Fokker E.V Volume 2.

This model represents the Fokker E.V flown by Hans Goerth whilst serving with MJF III in 1918. Two Fokker E.V aircraft were delivered to MJF III on the 10 August 1918 and were serial numbers 144/18 and 155/18, either of which could have been flown by Goerth. It is generally accepted that this aircraft had the standard Fokker lozenge fabric covering the fuselage with the wing having a green/brown top surface and turquoise/blue underside. As is usual with WW1 black and white photos, it is conjecture as to the colours of the engine cowl, wheel covers and tailplane. 'Pheon' details the colours as yellow with black bars on the elevators (3 each side). The colour of the number 3 on the fuselage is thought to be either yellow or white. The fate of this particular aircraft is not known.

NOTE: If using the 'Pheon' aftermarket decals, this aircrafts marking are on the Fokker E.V (Volume 2 set), but it does not have either of the serial numbers required, as that information came after the decals were produced. However, serial number 155/18 can be created from those serial numbers on this sheet.

The aircraft specifications were:

Length 5.86 m (19ft 3in)

Wingspan 8.34 m (27ft 4in)

Height 2.6 m (8ft 6in)

Wing Area 10.7 m² (115 sq ft)

Empty Weight 405 kg (893 lbs)

Total Weight 605 Kg (1,334 lbs)

Maximum Speed 204k/h (127 mph)

Engine Oberursel Ur.II 9 cylinder rotary (82 kW (110 hp)).

Propeller manufactured by 'Axial'

Weapons - two fixed 7.92 LMG 08/15 Spandau synchronised machine gun.

The aircraft consisted of a single, fully cantilevered, 'parasol' wing of plywood covered construction and the fuselage was of metal tubular construction, as were the wing support struts and the undercarriage struts. The fuselage was covered in linen with plywood fairings on the forward fuselage sides (as on the Fokker DR.1 Triplane) and on the top of the fuselage, aft of the pilot. The initial production batches of this aircraft were designated as the Fokker E.V, but after structural problems and subsequent re-designs, the remaining production aircraft were designated as the Fokker D.VIII.

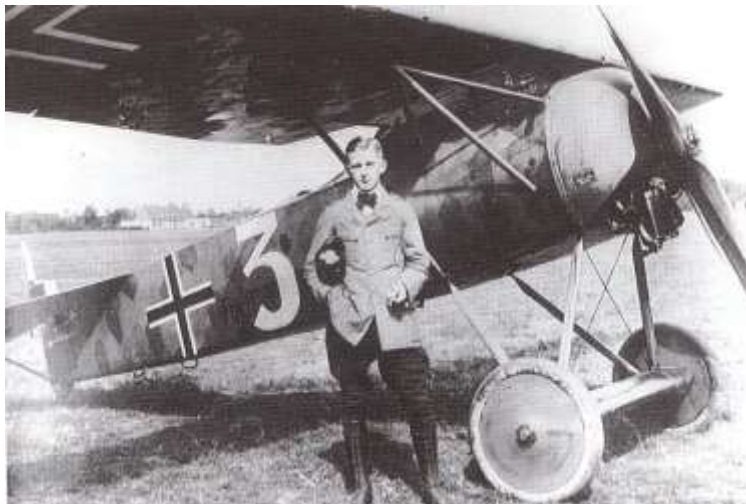

PART 1 - THE MODEL

(MicroMir Models No.32-001)

This model is manufactured by the Ukraine Company of 'MicroMir'. The model is essentially a re-tooled version of the former model by 'Avis'.

The kit is manufactured in styrene (plastic) and according to MicroMir, has been updated to include, amongst other thing, a more accurate wing.

The kit instructions are basic, but includes colour profiles for three different colour schemes. Also supplied are a decal sheet, photo-etch parts and a windscreen transparency.

As with most models, there is scope for modifications to enhance the model, such as:

Additional decals from 'Aviattic' (this build) and 'Pheon'.

Engine cowl and pilots seat from 'Aviattic'.

Engine from 'Roden'.

Replacement machine guns from 'Gaspach'.

Instruments from 'Airscale'.

Although this kit is from a re-tooled set of molds, the age of the molds is obvious and there are various issues with some of the parts (refer to Part 1 - Modifications or Corrections)

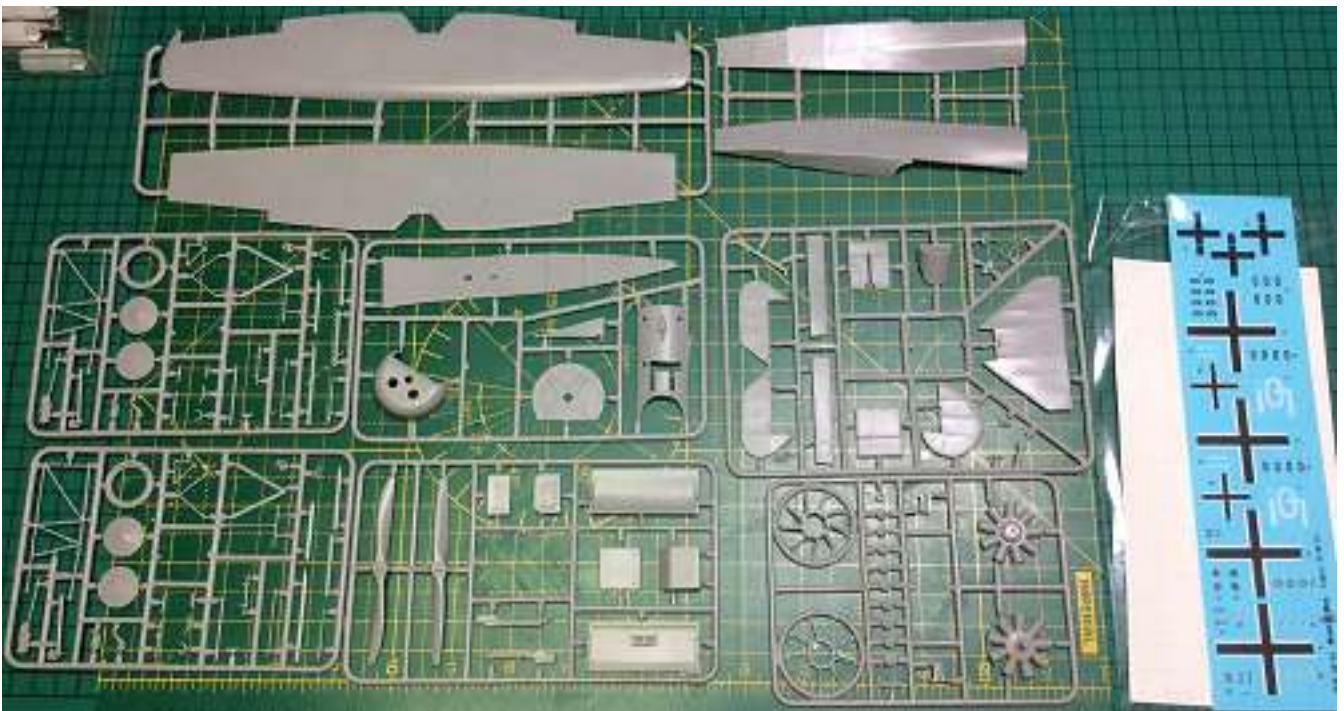



CAT.NO.32-001
SCALE 1:32

Германський винищувач

Fokker E.V/D.VIII

German monoplane fighter

Останній прийнятий на озброєння в роки Першої світової війни винищувач фірми "Фоккер" був спроектований по досить рідкісною аеродинамічною схемою моноплана-парасоля.

"Фоккер" E.V був серійним варіантом прототипу V.28, що об'єднав у своїй конструкції ряд рішень, що використовувалися на більш ранніх літаках. Силова установка (Оберурсале Ur.II), фюзеляж і горизонтальне оперення - зварні зі сталевих труб з полотняною обшивкою, аналогічні "Фоккер" D.VI, а вертикальне - таке ж, як у D.VII. Відмінною рисою "Фоккер" E.V було свobodнонесуще дерев'яне крило трапецієподібної форми досить товстого профілю з фанерною працюючою обшивкою, що було вельми не типово для тодішніх аеропланів. Крило кріпилося до фюзеляжу за допомогою стійок, зроблених із сталевих труб. У деяких екземплярів в обтічнику колісної осі були зроблені паливний і масляний баки. Озброєння - два синхронних LMG 08/15. Автор проекту - головний конструктор фірми Фоккер Флюгцойгверке ГмБХ, Рейнольд Платц.

Під час конкурсу винищувачів, що проводився німецькою Армією в травні і червні 1918 року, V.28 справив враження як на офіційних осіб, так і на пілотів своєю маневреністю, злітними характеристиками і скоропідйомністю. Перший досвід бойового застосування виявив проблеми зі змазкою двигуна і міцністю крила, що призвело до тимчасового припинення серійного випуску та експлуатації машини.

Серійний випуск доопрацьованої моделі літака було продовжено під новим позначенням D.VIII. Через капітуляцію Німеччини в війська надійшла порівняно невелика кількість D.VIII. Існували плани по розробці варіантів із більш потужними двигунами, але жоден з них не пішов у серію. Всього було випущено 139 E.V і 150 D.VIII, причому 53 з останніх були поставлені вже після капітуляції без двигунів.

The Fokker E.V was a German parasol-monoplane fighter aircraft designed by Reinhold Platz and built by Fokker-Flugzeugwerke. The E.V was the last Fokker design to become operational with the Luftstreitkräfte, entering service in the last months of World War I.

The Fokker D.VIII was a rare monoplane design of World War 1 and regarded as one of the best fighters of the German Empire in the conflict. It provided a stellar blend of survivability, firepower and adaptability within a sturdy rugged airframe. The type appeared in the final months of the war in 1918 (an armistice was signed in November of 1918) and was produced in approximately 295 examples by Fokker Flugzeug-Werke GmbH of Imperial Germany. The D.VIII was a further evolution of the Fokker E.V design which exhibited structurally-related wing issues due to poor construction methods. The E.V design was revised and became known under the designation of D.VIII.

The Fokker D.VIII garnered the nickname of "Flying Razor" by pilots of the Triple Entente. The D.VIII had the distinction of scoring the last aerial victory of the war.

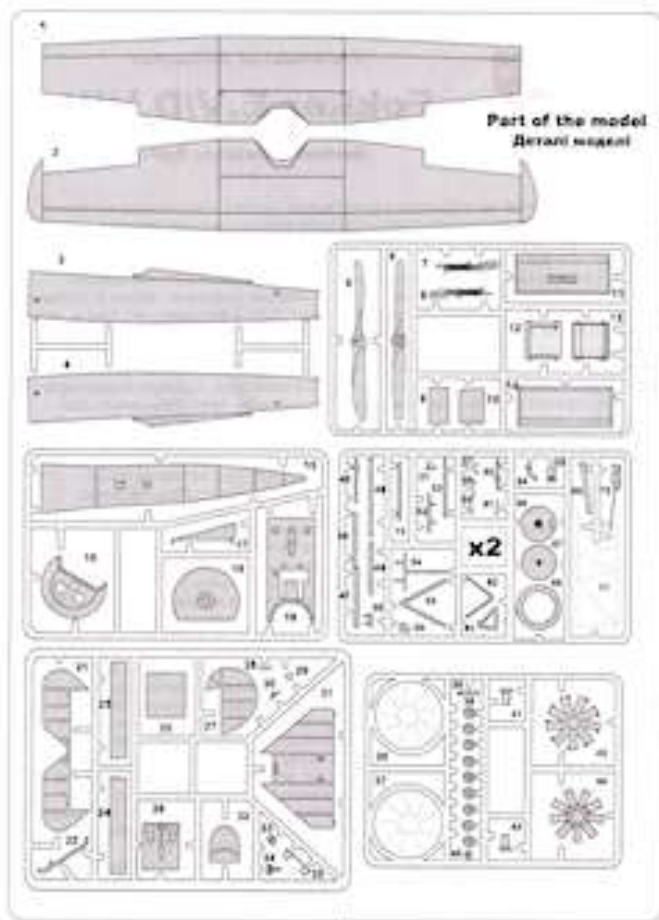

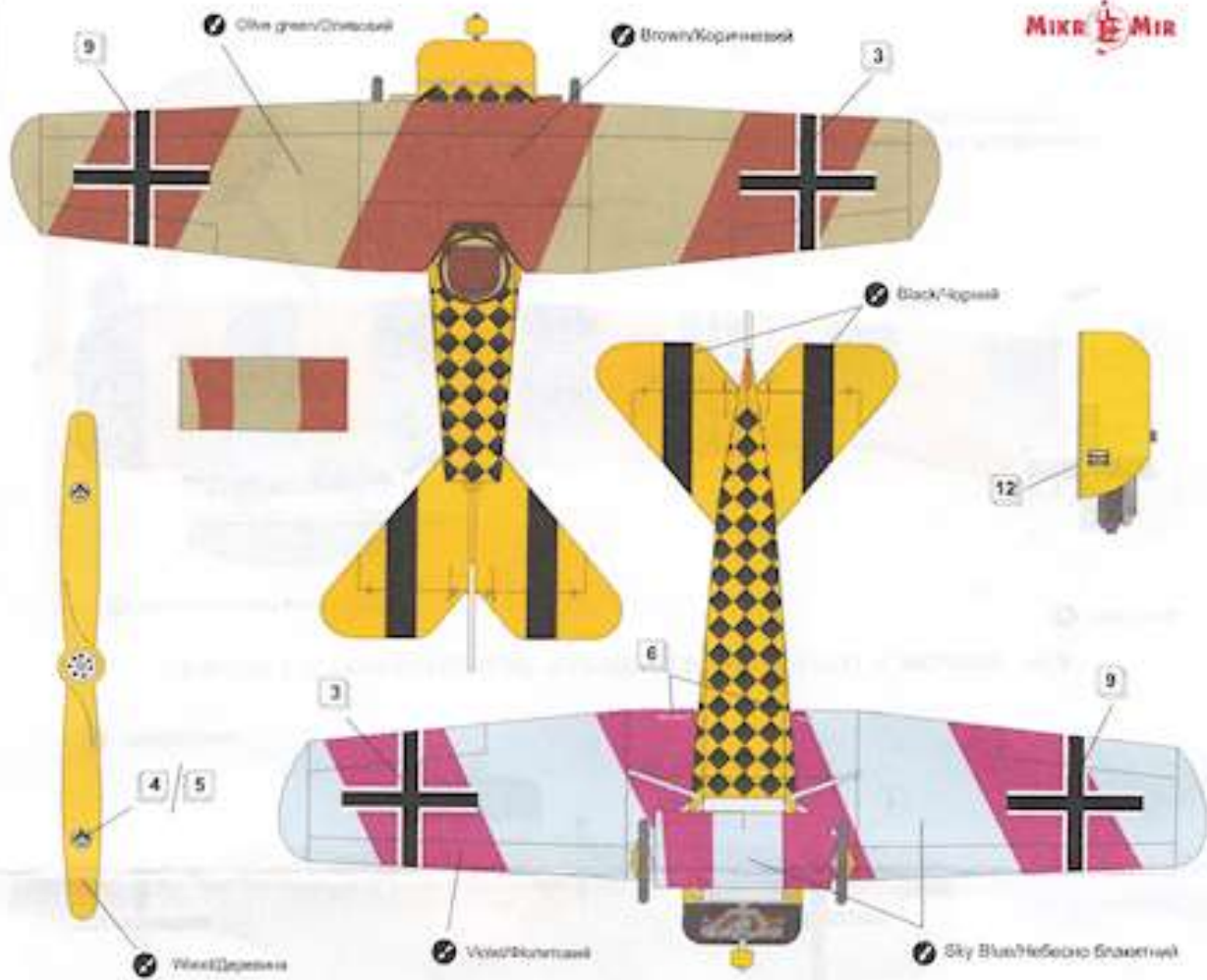

FOKKER E.V. 138/18 LT.N.Z.SEE GOTTHARD SACHSENBERG
MARINE FELD JAGDGRUPPE I, FLANDERN, COOLKERKE AIRFIELD, AUGUST 1918

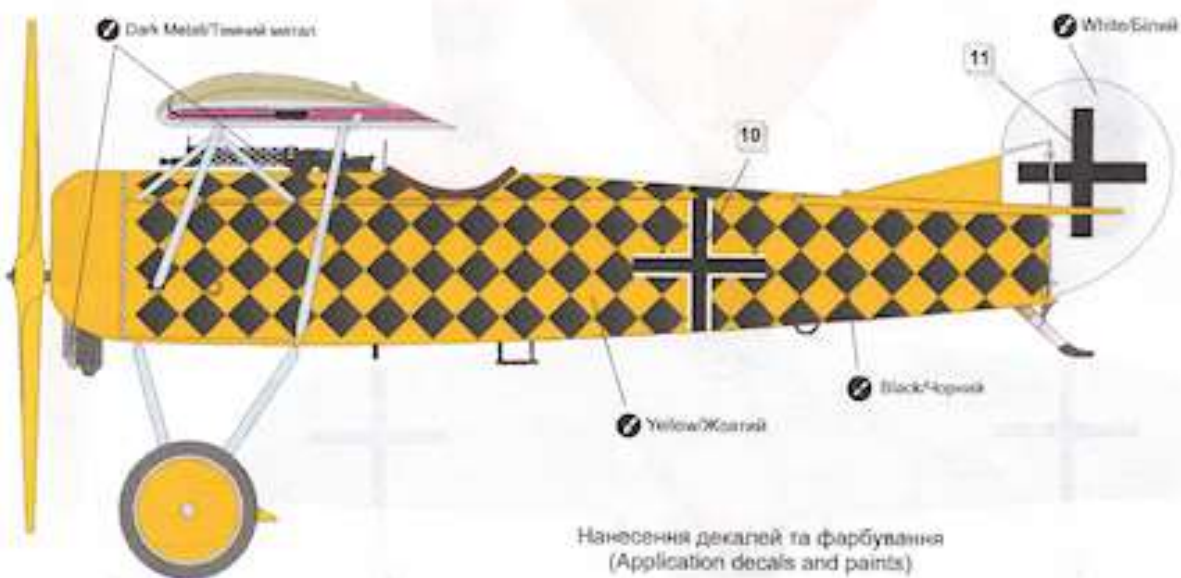

Нанесення декалей та фарбування
(Application decals and paints)

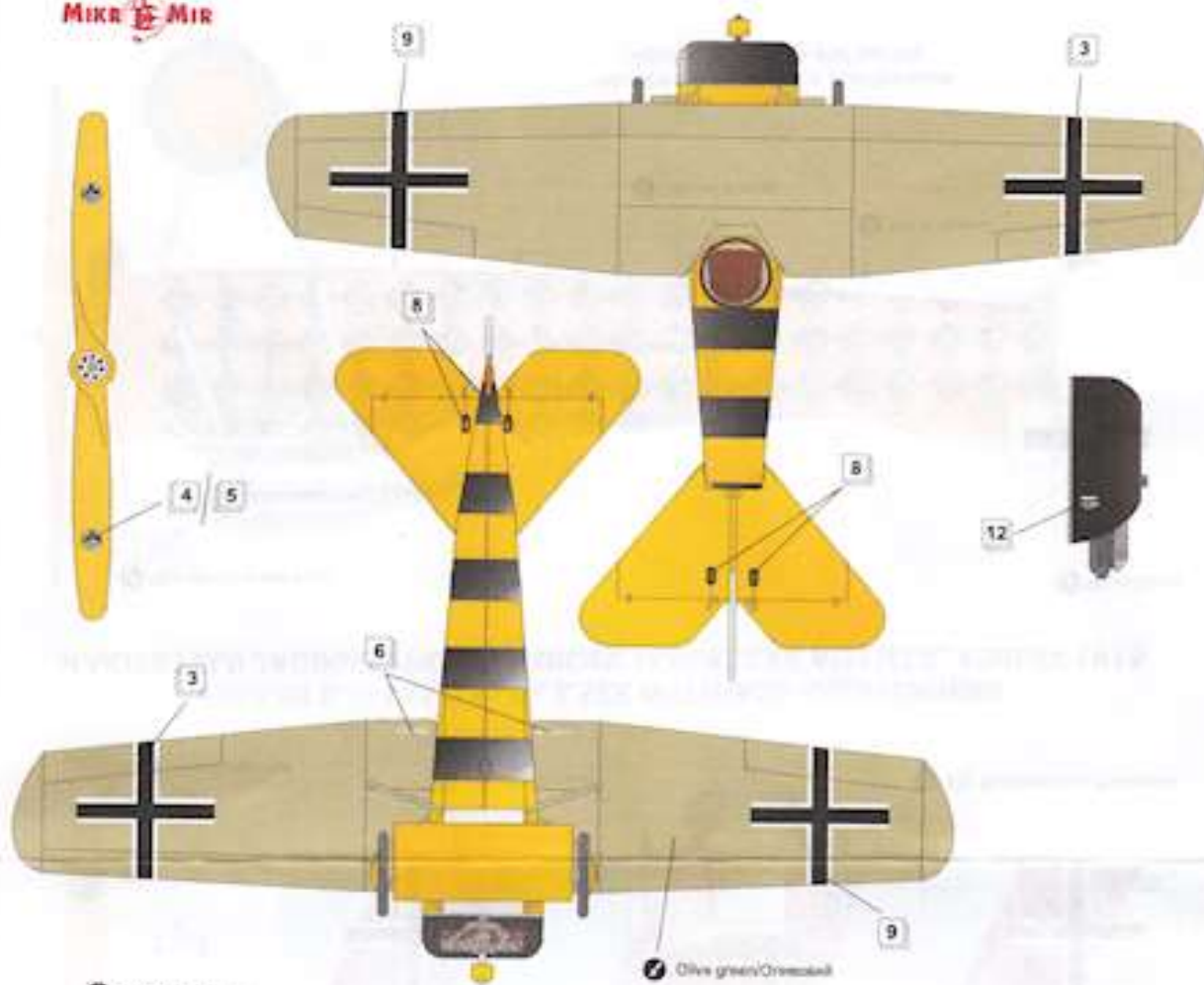

Wood/Дерево

Dark Metal/Темний метал

FOKKER E.V, THEO OSTERKAMP, MARINE FELD JAGDSTAFFEL II, BELGIUM, 1918

Dark Metal/Темний метал

White/Білий

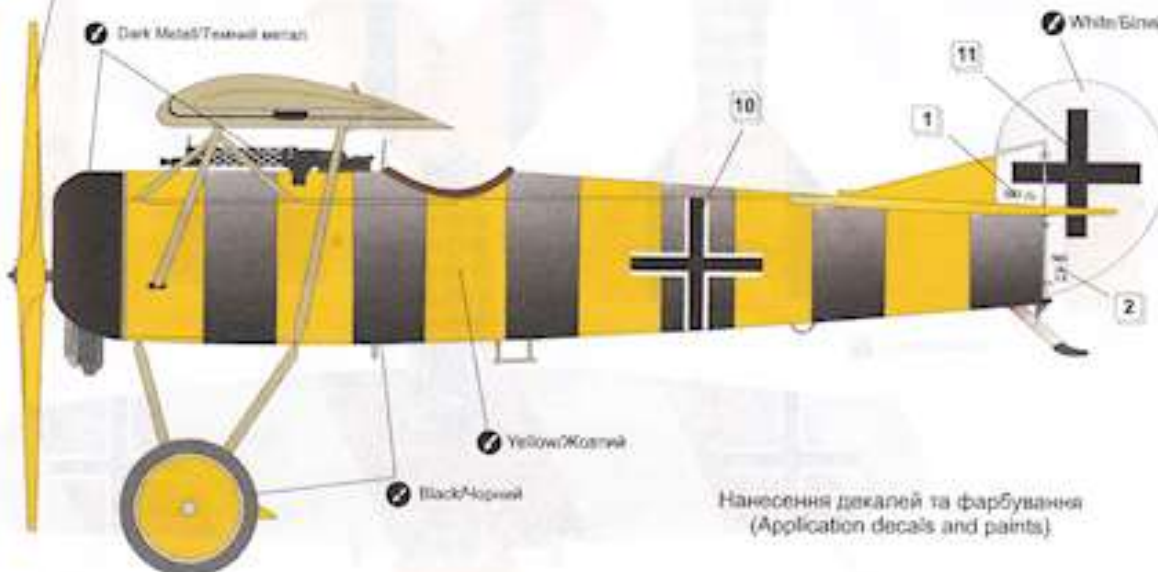

Yellow/Жовтий

Black/Чорний

Нанесення декалей та фарбування
(Application decals and paints)

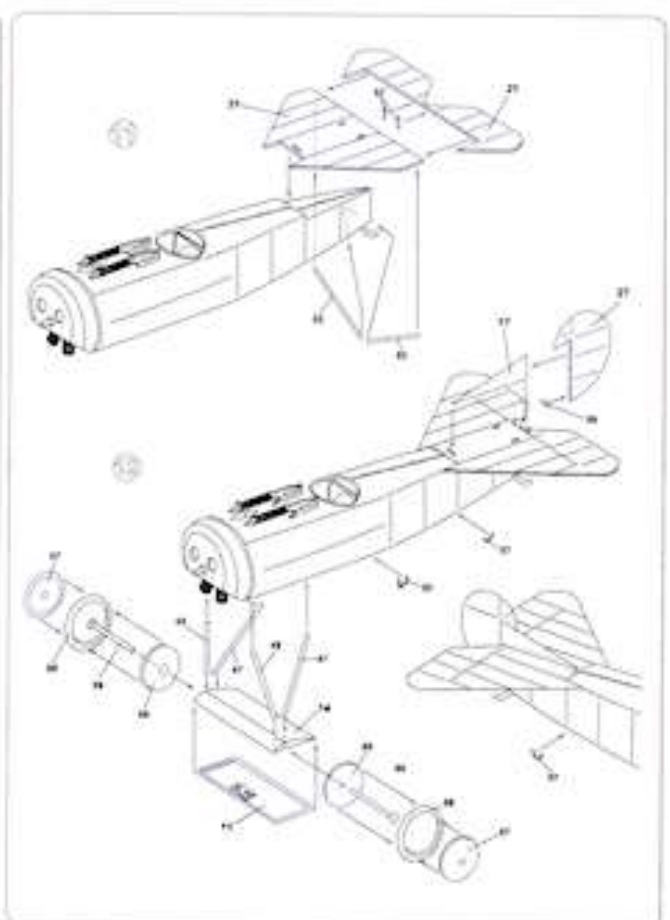
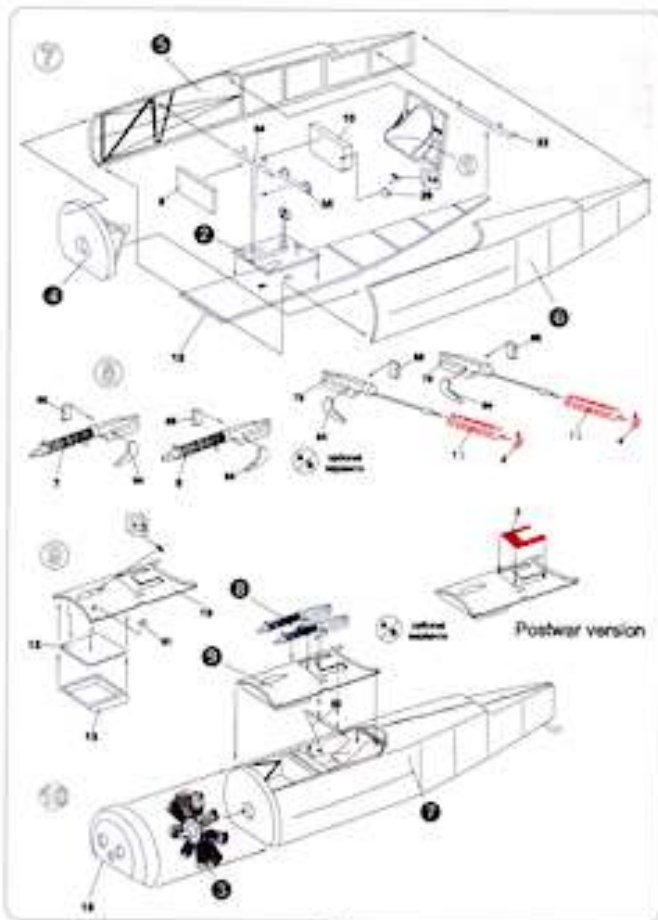
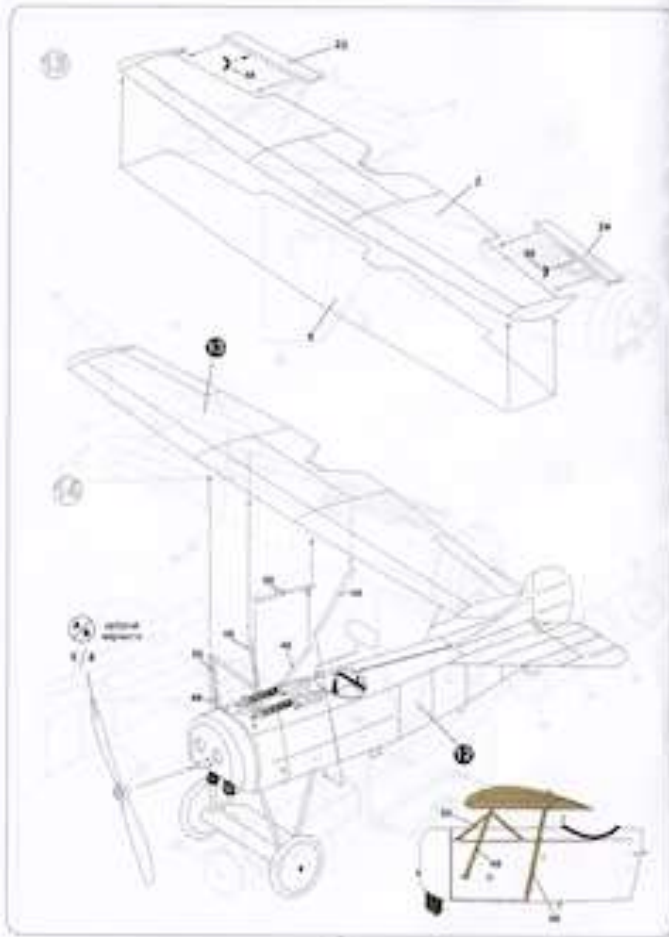

Modifications and corrections:

General surfaces:

The kit fuselage halves have, at the rear end, three pre-molded outlets for the rudder and elevator control lines, which need to be drilled out to accept the control cables later in the build. There are faint outlines of the original molded control outlets that are still showing and need to be sanded out. Also there are surface blemishes over the surfaces, caused from the finish in the tool molds and there are pre-molded carburettor intakes and aileron control cable outlets that need to be drilled out. Just forward from the tailplane, and on the wing tips are mold 'sink' marks, which need to be filled and sanded out. Finally the panel outlines need to be re-scribed.

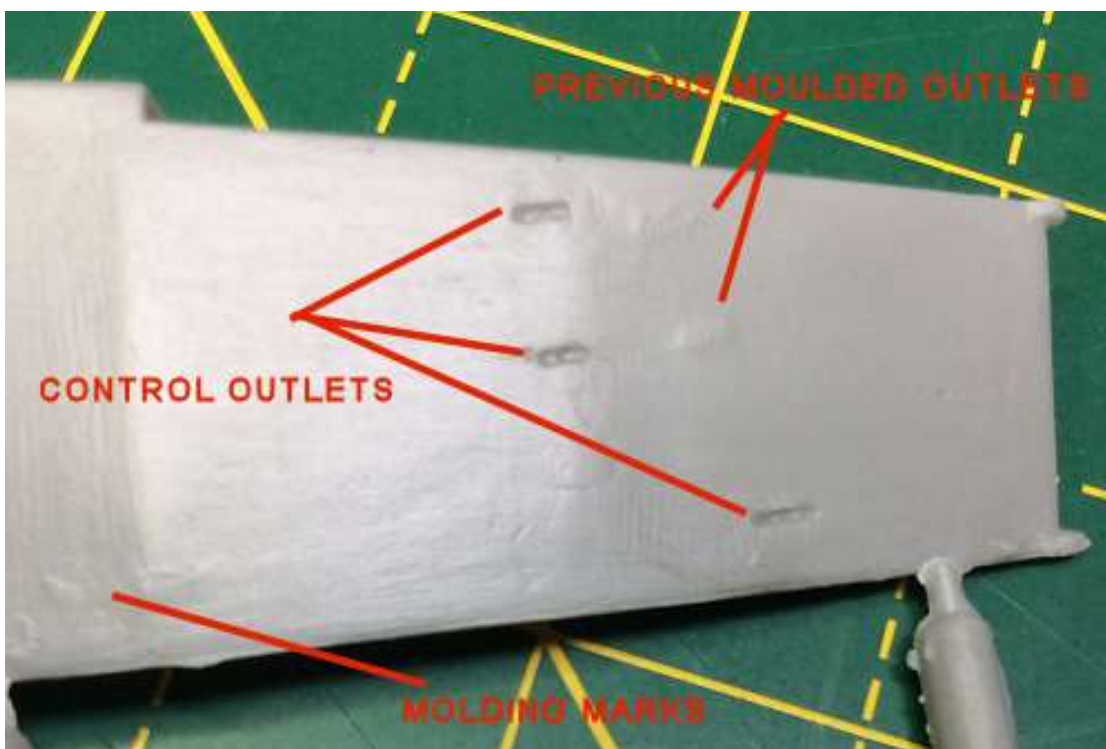
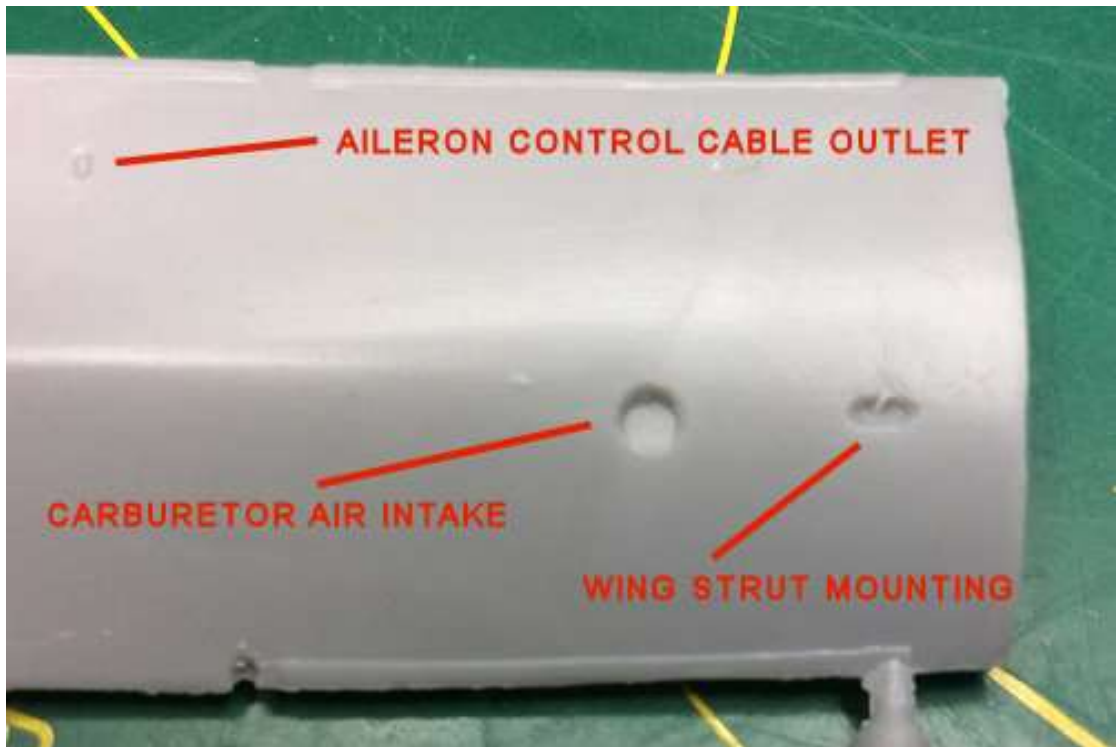



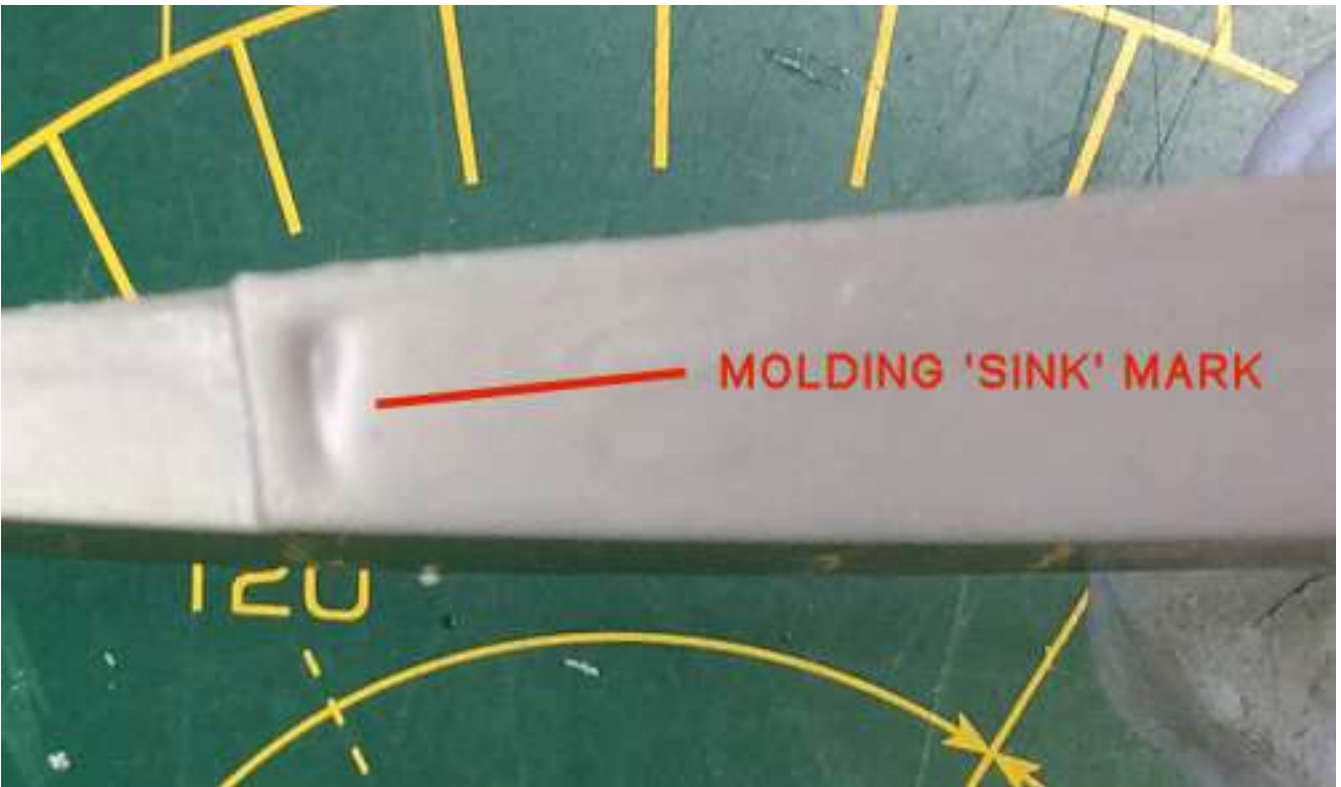
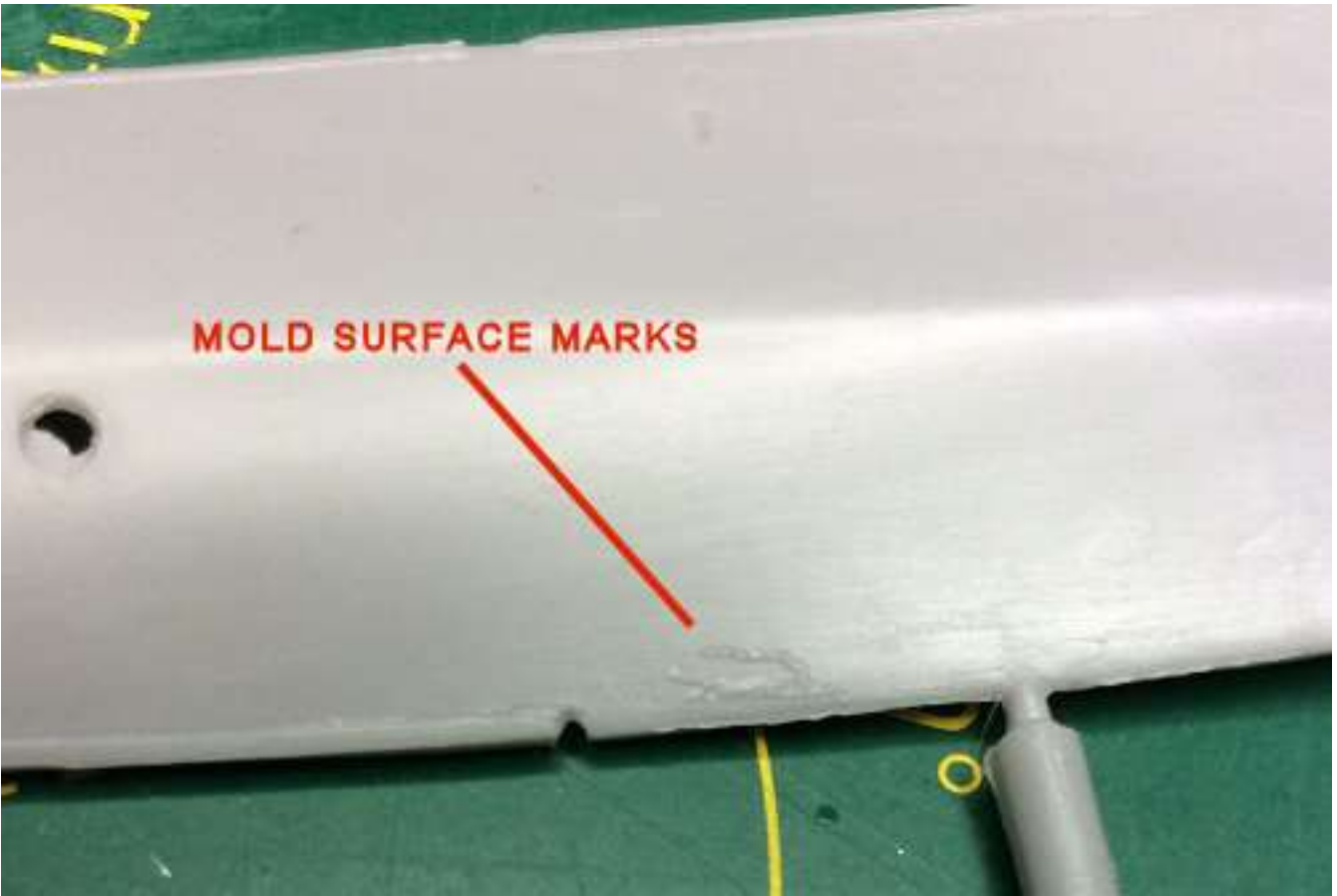

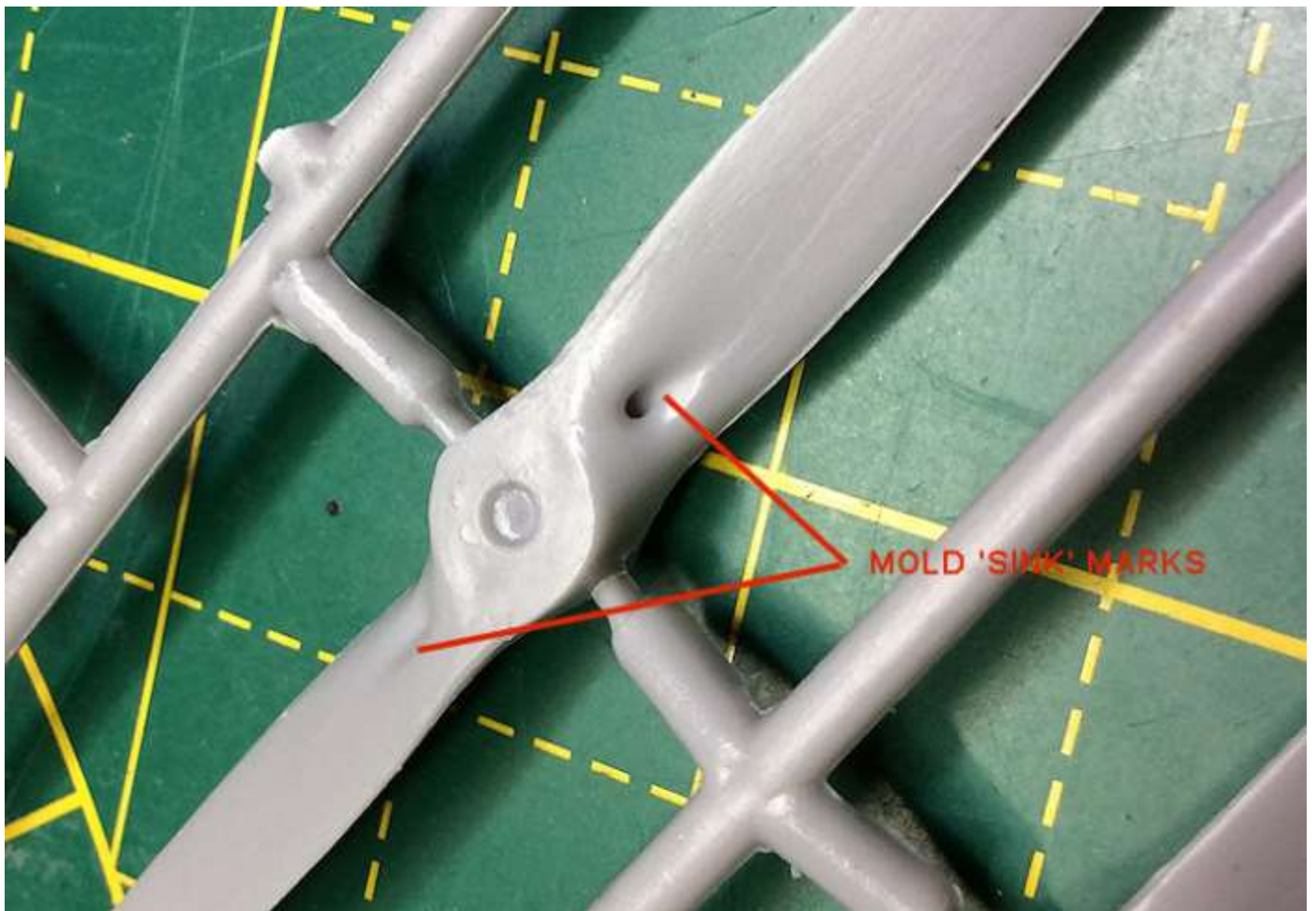
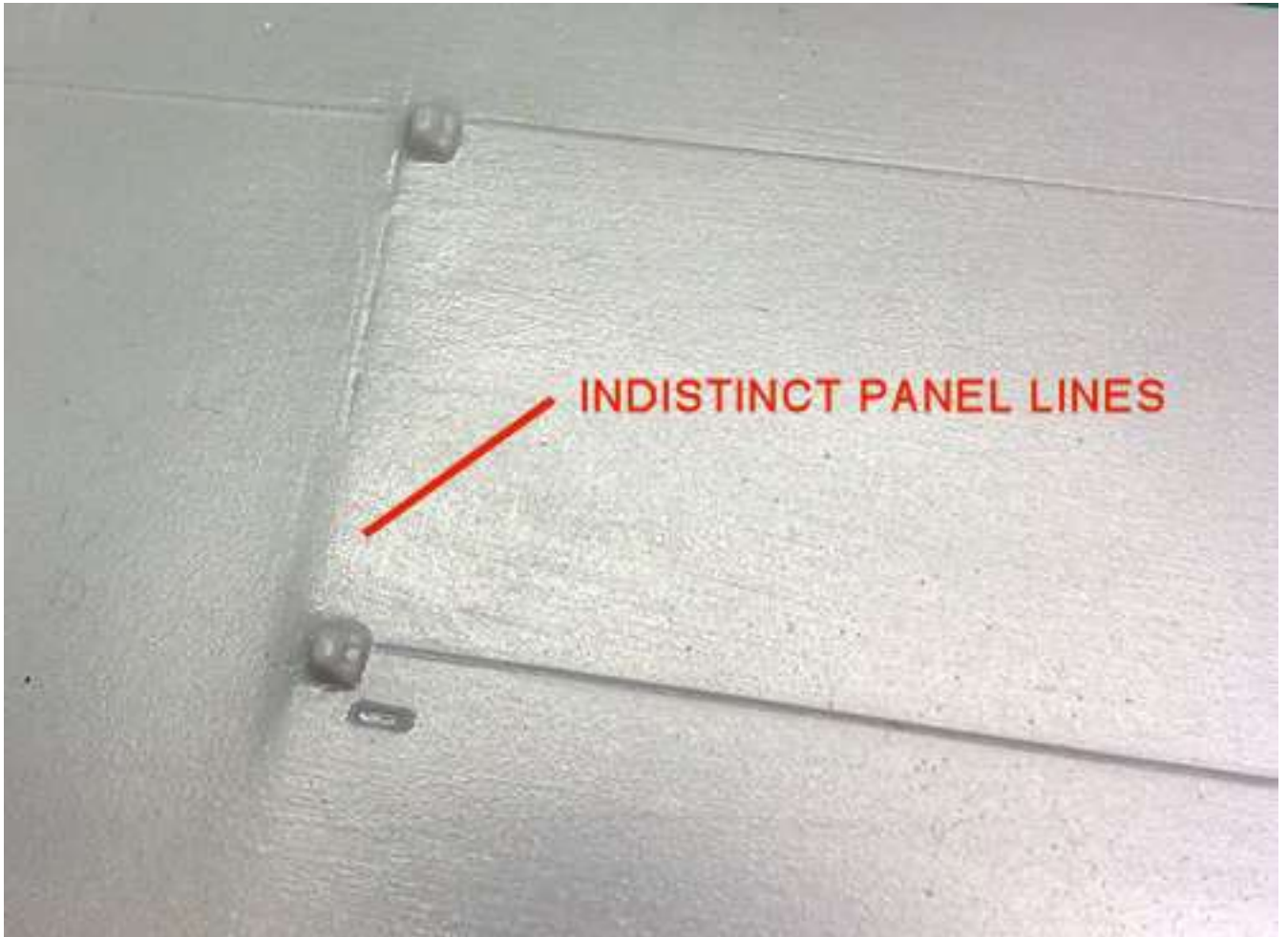



The mold 'sink' holes in the propeller and top rear of the fuselage halves were filled with 'Perfect Plastic Putty' and once set, were sanded smooth.



All of the control cable outlets in the wing, fuselage halves and tailplane were drilled out using a 0.6 mm diameter drill, including elongating them to form slots, rather than just a hole.



Any surface marks or blemishes were carefully scrapped away using a curved scalpel blade then sanded smooth.



The wing panel lines were re-scribed, the mold 'sink' marks filled and the aileron control cable outs drilled out.

Once this was all completed, the wing surfaces were sanded smooth.



Rigging points:

The only rigging points that required 'anchors' are those for the undercarriage cross-bracing. All other structural or control rigging does not require rigging anchors.

The anchors are from the 'Gaspach Elite Accessories' ('Anchors').

The turnbuckles are from 'Gaspach Elite Accessories' ('One End' turnbuckles).

I drilled a 0.4 mm diameter hole into the undercarriage fairing, close to and inboard of each of the undercarriage forward support strut locations. The holes were angled to approximately the angle of the bracing cables, when installed. The 'One End' turnbuckles were then secured in position using thin CA adhesive.

I then drilled a 0.4 mm diameter hole into the bottom of the fuselage, close to and inboard of each of the undercarriage forward support strut locations. The holes were angled to approximately the angle of the bracing cables, when installed. The anchors were then secured in position using thin CA adhesive.

The rigging required at the fuselage anchors and the undercarriage fairing turnbuckles is described in Part 9 ('cable tie-backs').



Engine.

The supplied engine lacks detail definition, so for this build I chose instead to use an aftermarket engine, the Oberusel Ur.II from 'Roden' (kit No. 624).

The assembled engine is a little too large in overall diameter to fit inside the engine cowl. In order to rectify this, the engine cowl inner surface was scrapped thinner and five of the engine cylinder heads (those not seen with the engine cowl fitted) had the valve operating gear reduced, which allowed the engine to fit inside the engine cowl, without any contact.

In addition, the engine propeller shaft does not fit the kit supplied propeller. To modify the engine, the propeller shaft was cut away so as to be just proud of the engine cowl surface, when fitted. A hole of 1.0 mm diameter was drilled into the centre of the propeller shaft, to accept the propeller shaft brass 'pin'.

Refer to the following page for the modifications to the engine cowl.



Engine cowl.

The kit supplied engine cowl lacks detail requires some work to make it more accurate and to create greater clearance inside to allow fitting of the replacement engine from Roden (Kit No.624). An easier option will be to fit an aftermarket cowl, such as that being prepared by 'Aviatic' and 'Pheon' and which is due to be released before the end of 2017.

The engine cowl has several areas that need to be addressed.

1. The thickness of the cowl, where visible, was reduced by scrapping and sanding
2. The inner surface of the cowl was also reduced to give clearance for the replacement Roden engine (refer to .
3. The front face of the cowl should have a circular rivet ring. This was corrected by fitting the photo-etch rivet ring from the photo-etch sheet (Jadar Hobby Shop - Part No.32028 Fokker DR.1 1/32).

Refer to the following page for the modifications to the propeller.



Propeller.

The kit supplied propeller required modifications in order for it to fit the replacement 'Roden' engine.

1. The holes around the front propeller boss were shallow drilled using 0.6 mm and 0.4 mm diameter drills. This gave the holes in the boss a more realistic 'depth' to the propeller.
2. A hole of 1.0 mm diameter was drilled through the centre of the propeller retaining nut on the front face of the propeller boss. This hole was drilled completely through the propeller.
3. A brass rod of 1.0 mm diameter was secured in the hole, using thin CA adhesive. A small amount of the rod was left protruding from the retaining nut.
4. The brass rod was filed flush to the surface of the retaining nut.



5. The photo-etch propeller boss plate, from the supplied 'Roden' engine kit photo-etch, was secured to the rear face of the propeller using thin Tamiya adhesive.
6. The brass rod was then shortened so that once installed into the hole in the engine propeller shaft, it could be correctly positioned against the engine cowl.it



To ensure everything would fit correctly, the engine was test fitted inside the engine cowl and the propeller fitted into the engine propeller shaft.



Stacking Pads:

The actual aircraft had 'stacking pads' fitted into the leading edge of the wing. These were used to protect the wing leading edge whilst the wing was being transported, with the wing vertical and resting on the leading edge pads. I have positioned these as shown in the photo below.

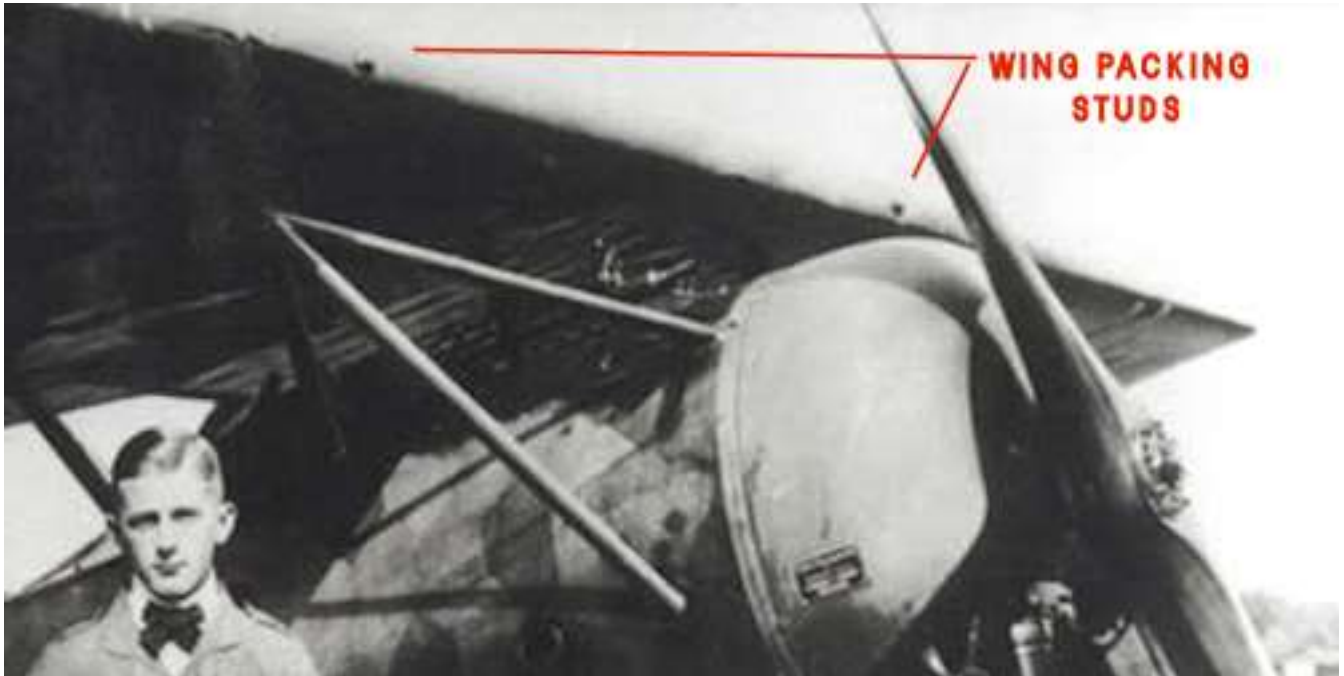

To do this I drilled holes of 1.0 mm diameter into the wing leading edge and inserted short lengths of 1.0 mm brass rod (Albion Alloys), which was secured using thin CA adhesive. The exposed ends of the rods were rounded slightly before being installed. The 'pads' were painted as a final step, once the wing was completed.



Blast plates.

The two blast plates for the gun muzzles were made from 0.2 mm thick plastic card and the corrugations pressed in with a paper embossing tool. They were then fixed to the cockpit top decking, below where the gun muzzles will be located.



Carburettor air intakes.

The kit has pre-molded holes where the carburettor air intakes should be (one on each side of the fuselage). In reality, these were not just holes, but had air intake tubes protruding, the ends of which were slightly angled 'into wind'.

To represent these intake tubes, after first drilling out the holes in the fuselage, I fitted short lengths of 2.0 mm diameter brass tube, drilled out to 1.5mm diameter and suitably chamfered at the outside ends at 45 degree angles. These were secured in positioned using thin CA adhesive.



Aileron animation:

To present the aircraft with flying controls in 'relaxed' positions, it was necessary to pin the ailerons in the desired positions.

To do this I drilled 0.6 mm diameter holes at three locations along the aileron leading edges. Brass tubes of 0.6 mm diameter were then secured into the holes, using thin CA adhesive. Each aileron was then laid in position against its wing aperture and the position of each pin lightly marked onto the wing surface. Using these marks as a guide, I drilled three holes along the centre line of the wing aperture. The aileron pins were located into the wing holes and the aileron eased into the aperture and against the wing trailing edge.

NOTE: Any slight misalignment of the aileron to the wing can be rectified by gently applying pressure to the aileron to bend the brass pins to alter the position of the aileron.

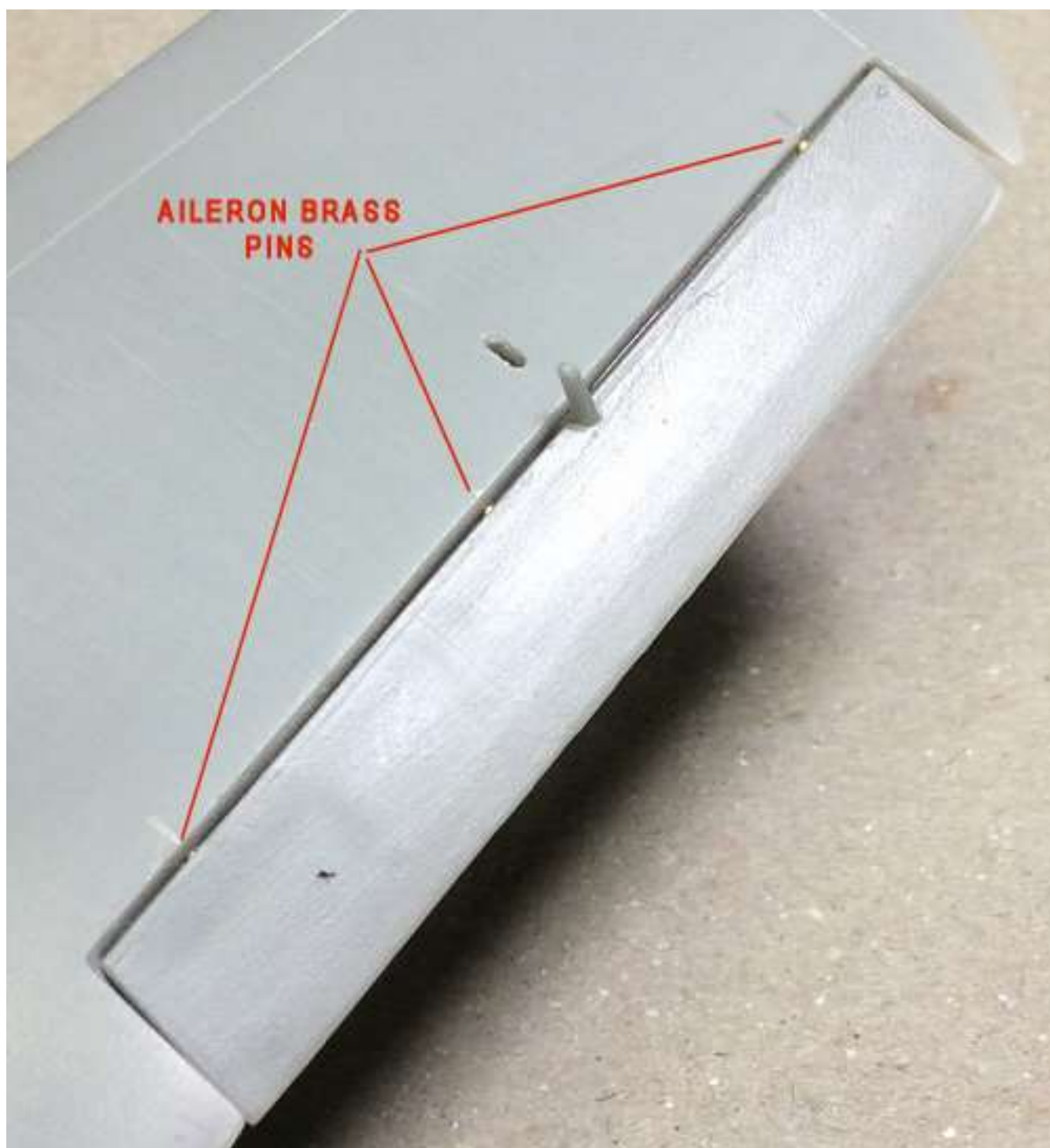

Tailplane:

Once the cockpit is completed and the two fuselage halves are closed up any seams and joins should be cleaned up and filled if required, then cleaned and finally checked.

It's at this point that the tailplane fit can be addressed. The kit supplied tailplane sits proud of the rear fuselage joint when positioned onto the fuselage recess.

NOTE: When working with the tailplane, always ensure it is facing the correct way as both sides look similar. The top surface will be the one with the two elevator control lines apertures furthest rearwards.

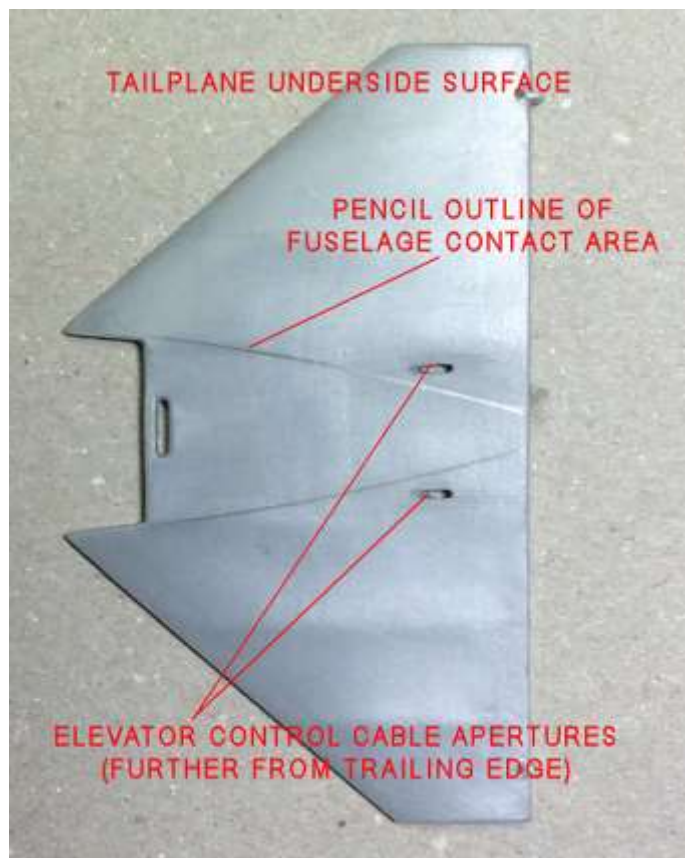
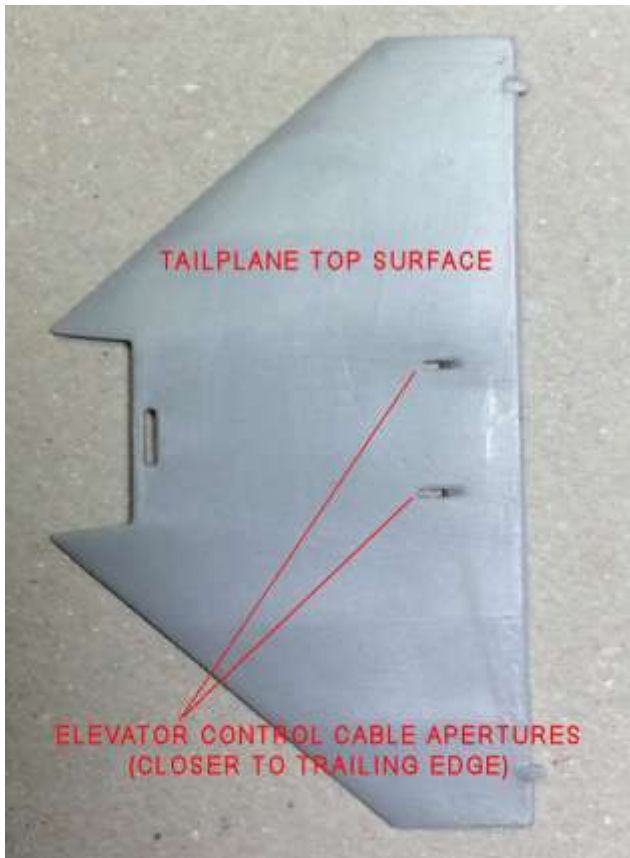

The easiest way to achieve a better fit of the tailplane is to either:

1. Scrape away the centre area only of the fuselage recess, until it is thin enough to be able to cut it out with a sharp scalpel blade.
2. Drill around the centre area only of the fuselage recess then cut it out and clean up the edges.

Once this done the edges of the recess can easily be scrapped or sanded down until the tailplane sits flush with the fuselage top.



To replicate the support for the forward fin attachment, I secured a short length of 1.0mm diameter brass rod to the underside on the tailplane aperture, using thin CA adhesive.



The shot below shows the tailplane immediately after fitting to the fuselage. Once the tailplane has been secured to the fuselage recess and when the adhesive is dry, the Join can be scrapped or sanded to blend the fuselage and tailplane, but remember to leave a slight join line, as on the actual aircraft.



The following shot shows the tailplane and fin fitted and primed with Tamiya Fine Grey primer.



Wing support struts:

The kit supplied wing support struts are rather weak and have no real positive location into the fuselage, which are just depressions. In addition, the single wing when assembled, is quite heavy. The 'Pheon' decals I chose come with a paper guide for constructing an assembly jig for the wing and undercarriage struts. However, this can be a time consuming task to cut and then assemble.

Therefore I decided to construct the wing support struts, using brass micro-tube and solid rod. The tube and rod used was Albion Alloy's 1.2 mm diameter tube (MBT12) and 0.5 mm rod (BW05). The struts are created using the 'Strutter' from Model Skills (Albion Alloy's). The 'Strutter' is a pair of hardened steel jaws, one of which has two steel pins, the other has location holes for the pins. These are used in a normal medium sized bench vice. A length of tube, with an appropriate solid rod inserted is positioned across the two pins of the 'Strutter' and the vice jaws are then tightened, which tips the 'Strutter' jaws to crush the brass tube around the inserted rod. Unless the tube is really crushed, the rod should be able to be removed. Once all struts have been created they can be soft soldered together, including inserted locating rods, which are used to attach the struts to the model. In this way the wing is supported by brass struts with solid rod attachments, which is more sturdy than the kits supplied plastic struts (kit parts 46, 48 and 55).



First I constructed the two 'tripod' strut wing support assemblies supplied in the kit (parts 46 and 55). These were offered up against the fuselage assembly, to ensure correct alignment with the kit locations. They were also compared to 3 view drawings and the jig drawings supplied with the 'Pheon' decals. Using the assembled kit struts as a guide, I cut the brass tube lengths and chattered the ends as required to align the struts correctly to the fuselage and wing. I then put a strip of masking tape along the edge of an old ceramic tile and then pencilled the outline of the assembled kit v-strut (kit part 55).

The two brass tubes for making the v-strut (kit part 55) were positioned on the outline and held with 'BlueTack'. The third brass tube, for the v-strut to fuselage (kit part 46) was held in position in the same manner. The three struts were then soft soldered, including 0.5mm brass locating rod into each tube end. The single wing support struts (kit parts 48) were constructed in the same manner. **NOTE:** Before soldering the joints, ensure the strut for kit part 46 is correctly aligned to the fuselage for the left and right assemblies, as the two sides differ.

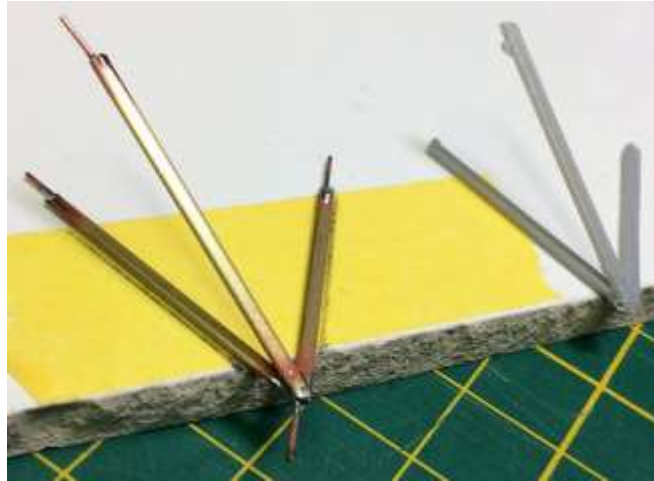

The kit locations needed to be drilled out to accept the new brass struts. Two holes of 0.6mm diameter holes were drilled through the existing location points on the top of the fuselage. The location holes forward of both of the carburettor intakes were drilled and were also opened up to accept the end of the long support strut. Both of the forward pre-molded 'lugs' on the underside of the wing were sanded off as they were no longer required and instead, holes of 0.6mm hole were drilled vertically into the wing to accept those strut locating pins. The location holes for the two single wing support struts were drilled at a shallow angle into the wing at the rear of the sanded off kit location 'lugs' and also horizontally into the bottom edge of the fuselage at the strut locations.

The strut assemblies were then cleaned and the 0.5mm locating rods bent to fit to the drilled location holes and the struts test fitted to mount the wing, with alignment adjustments carried out as required.

Below is a shot of the struts during test fitting. The struts will be primed prior to painting or the application of decals.

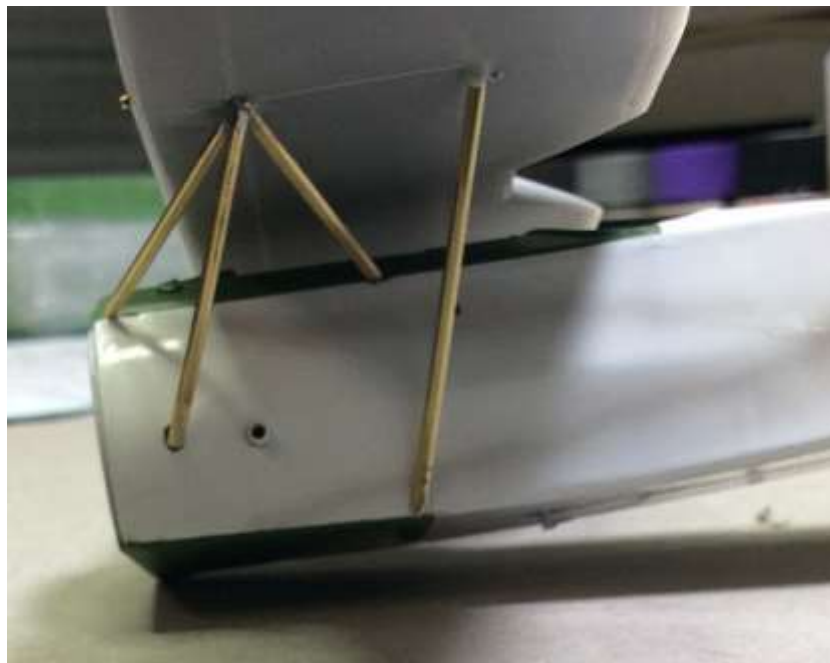

Undercarriage support struts:

The kit supplied undercarriage struts (parts 47 and 49), like those for supporting the wing, are rather weak and have no real positive location into the fuselage or undercarriage fairing, apart from some shallow depressions. Therefore, like the wing support struts, I decided to construct these from brass micro-tube and rod.

The tube and rod used was Albion Alloy's 1.6 mm diameter tube (MBT16) and 0.8 mm rod (BW08). The struts were created in the same manner as for the wing struts, using the 'Strutter' from Model Skills (Albion Alloy's).

The kit parts 47 and 49 were used as a guide for cutting the lengths of brass tube. These were offered up against the fuselage and undercarriage fairing, to ensure correct alignment with the kit locations. They were also compared to 3 view drawings and the jig drawings supplied with the 'Pheon' decals.

Then a length of 0.8mm diameter rod was passed through the tubes and the tubes were crushed in the 'Strutter'. The tubes were removed from the rod and the ends shaped as required to align with the undercarriage fairing and the fuselage. The rod was re-inserted and each end of the tubes were soft soldered. The rods were cut and the tube assemblies cleaned. Holes of 1.0mm diameter were then drilled into the undercarriage fairing and also the fuselage locations and the rod locating 'pins' bent to align the struts to their correct positions.

NOTE: Take care when drilling the two rear strut location holes. They are close to the already drilled wing rear strut location holes, as can be seen at the right side of the green access panel area in the shot below .

Below is a shot of the struts during test fitting and prior to priming and painting.



Pilot step and grab handles:

The kit supplied pilot step and the two ground crew grab handles are over size, so I decided to create replacements made from micro-tube.

Pilot step:

Using the kit item as a guide, I cut three lengths of 0.5mm diameter brass micro-tube, which has an internal diameter of 0.3mm. These were slid over a length of 0.3mm diameter micro-tube. The two sides of the step were then bent to a right angle and the joint secured using thin CA adhesive. The excess protruding nickel-silver tube was then cut away.

Ground crew grab handles:

Using the kit items as a guide, I gently heated a length of 0.4mm brass micro-tube, to anneal the tube and allow easier bending. Two lengths of the tube were then bent around a c2.3 drill bit, to produce the curved hoop shape of the grab handles. Excess tube was cut away from each end of the handles.

The pilot step and grab handles were then primed and when dry, painted with Tamiya NATO Black (XF69), ready for fitting later in the build.

The shot below shows the pilot step and grab handles after being primed, but not finish painted.



Ammunition containers access panel:

The actual aircraft had a rectangular access panel located outboard of the port (left hand) machine gun. I think this was to allow access to the ammunition containers for possibly loading or unloading ammunition rounds. This is not included in the kit. To replicate this panel I primed then painted a strip of Tamiya masking sheet to match the colour of the fuselage top decking. The hinge securing rivet line was imprinted using a 'Rosie the Riveter 0.65mm' and the hinge was cut from 0.2mm diameter nickel-silver micro-tube (Albion Alloys NSR02).

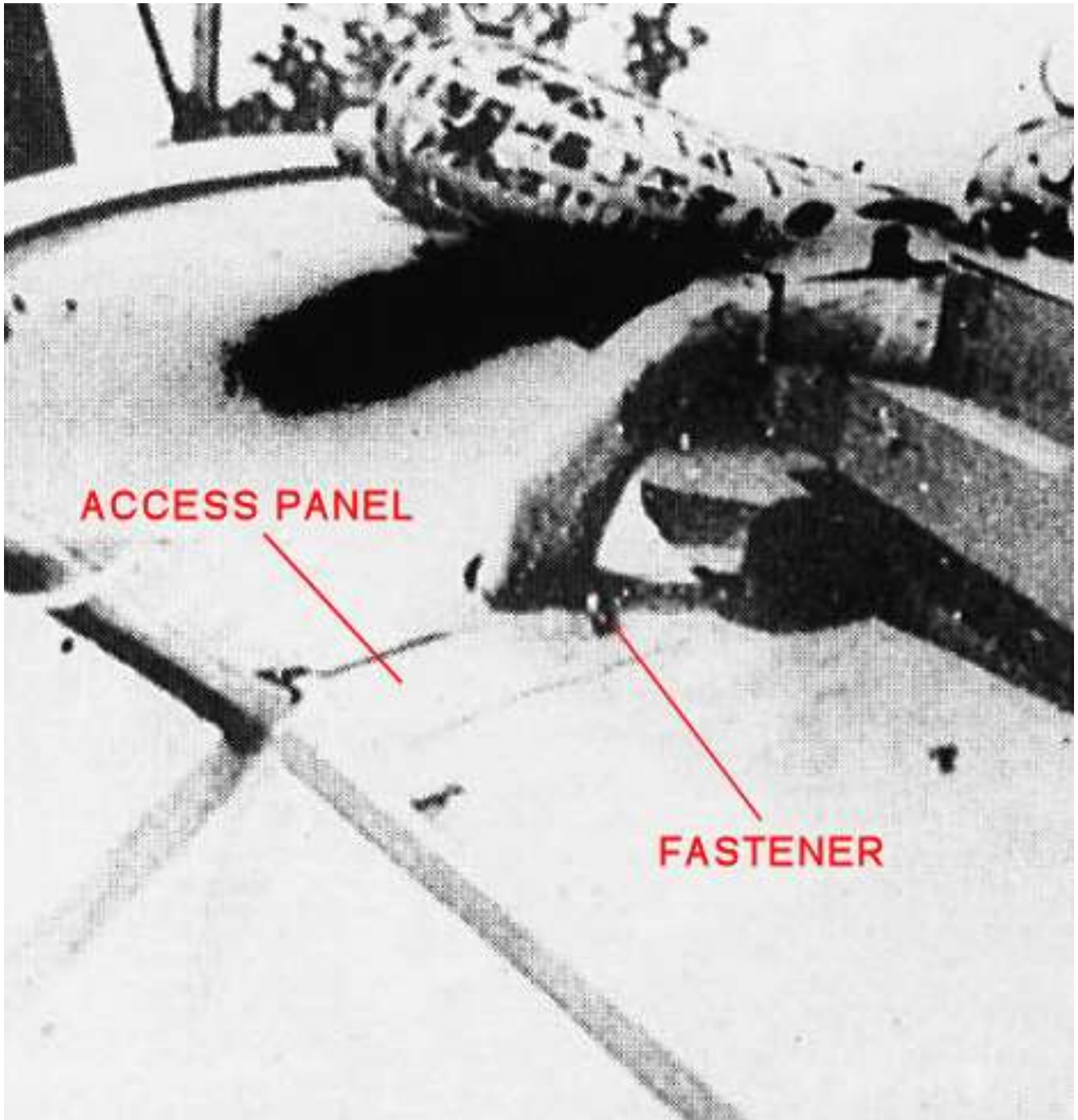

Cockpit detail:

References: Items 4 and 5 on page 1 of this build log.

There is not much in the way of authentic photos of the Fokker E.V cockpit, at least a complete cockpit. However the late 'Dan San Abbot', an acknowledged 'guru' on these matters, added the following to a thread posted on an aviation forum. He also states that this aircraft had no altimeter and was never produced with 5 colour lozenge coverings.

Left to right around to cockpit.

1. Midway down the diagonal strut just forward of the seat is the throttle and mixture controls handles fixed to a quadrant mounted to the strut.
 2. Mounted directly above on the upper longeron is a Bosch Magneto switch.
 3. Left machine gun and rear mount on the cross tube in front of the cockpit.
 4. Right machine gun and rear mount on the cross tube in front of the cockpit.
 5. The cross tube just forward has the front left and right machine gun mounts, and just below is the ammunition container for both machine guns in their left and right compartments.
 6. Immediately below the ammunition container is the tachometer mounted on a vertical tube in front of the ammunition container.
 7. Running down the front of the ammunition container, coming from the machine guns is the flexible drive housing that run under the ammunition container to the synchronizer assembly mounted on the back of the engine accessory case.
 8. Mounted on the right lower longeron with clips is a plywood panel about 150 mm wide and the upper end attached to diagonal side bracing with 2 clips for mounting the magnetic compass. The face of the compass is at the forward right corner of the pilot's seat.
 9. Immediately in front of the seat is the control stick.
 10. Mounted at the base of the vertical tube (where the Tachometer is mounted) is the rudder bar.
 11. The seat belt is attached to the lower quadrant at the lower longeron.
 12. The shoulder harness is mounted on the cross tube, behind the seat and between the Upper longerons.
-

When the Fokker E.V is compared to the Fokker Dr.1 triplane, the similarities in the forward fuselage section of these aircraft can't be ignored. In all probability, these areas of the Fokker DR.1 design were used as a basis for the design of the Fokker E.V.

Accepting this, along with Dan's information, I have constructed the cockpit of the E.V in a similar fashion to that of my model of the Fokker Dr.1, covered in a PDF download at this link:

<http://www.thatoneplease.co/logs.html>

The following pages detail the primary changes/modifications I have carried out for this model.

Compass and foot plates:

The kit instructions show the location of the compass as being on the port (left) side of the cockpit floor and forward of the pilots seat. However the compass should be located in a similar position, but on the right (starboard) side of the cockpit floor.

Generally the compass stand was given additional support by the fitting of 'stay', which was secured to the compass and the cockpit floor or side frame.

Before assembly I made the compass support from spare photo-etch, cut as a strip and then bent to fit to the cockpit floor and under the compass itself. This was secured in position using CA adhesive.

Mounted on the vertical bar and above the rudder bar is the Tachometer.

The pilots foot plates were scrapped off and replaced with the photo-etch plates from the Part No.32028 Fokker DR.1 (1/32) set.

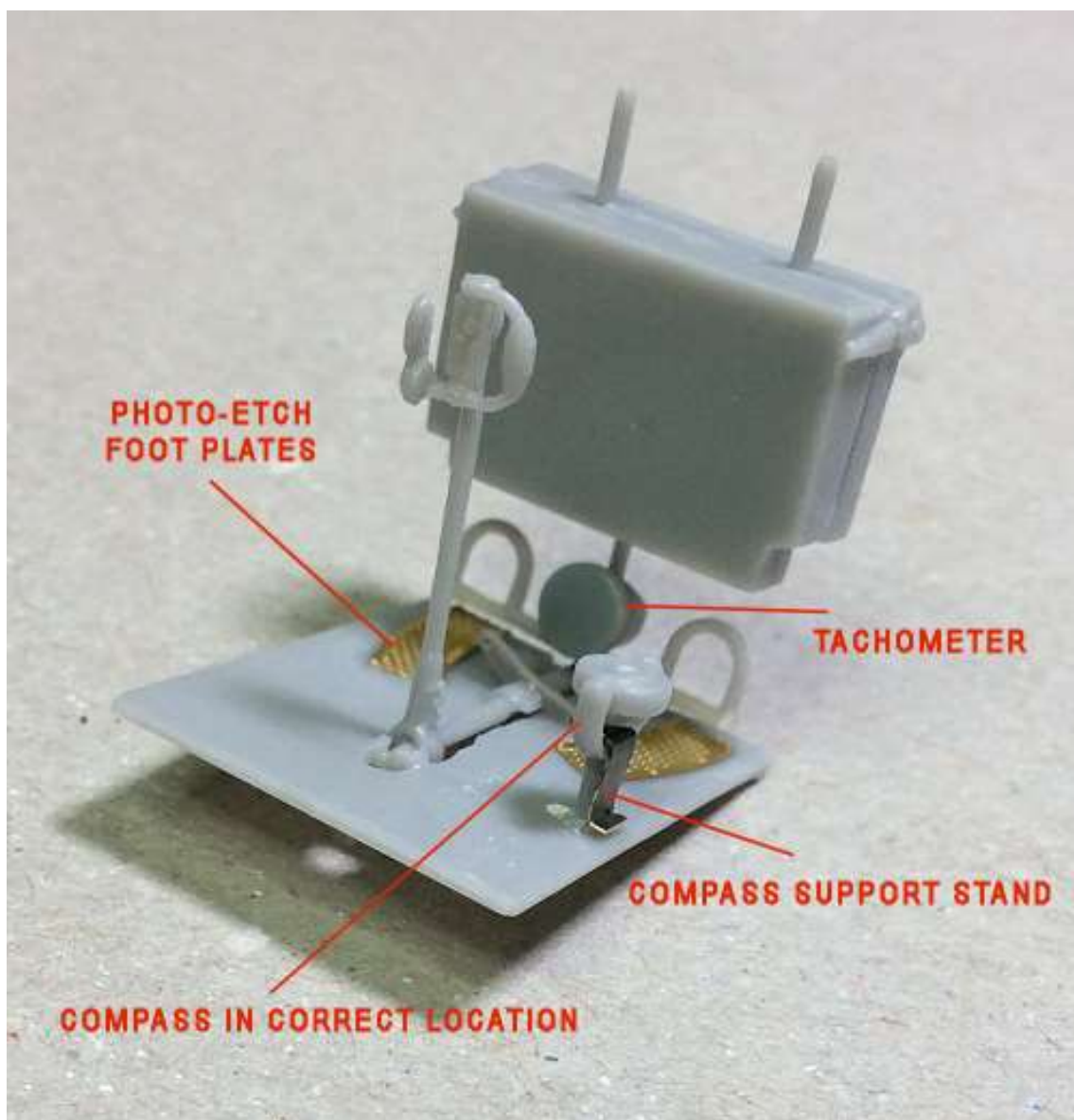

Cockpit frames and gun support cross bar:

Cockpit Frames

The kit parts carry a lot of 'flash' from the molding process and all of this flash needs to be removed before assembly. In particular is the flash on the cockpit frame work, which is excessive and care needs to be exercised when removing the flash or breakages or distortion will occur to the frames.

I chose to replace the two cockpit frames with ones made from 0.8 mm diameter brass tube (Albion Alloys).

Using the kit frame as a guide I cut the required lengths of brass tube and holding in position with Tamiya masking tape, soft soldered the joints. CA adhesive could be used instead of soldering, but the joints may not be as strong. Once completed I cleaned up the solder from each joint using needle files, scalpel blades and fine grit sanders.

NOTE: On the photo below, the area marked in red was cut away to allow for the frame to be fitted past the fuel/oil tank, which is installed under the fuselage top forward decking.

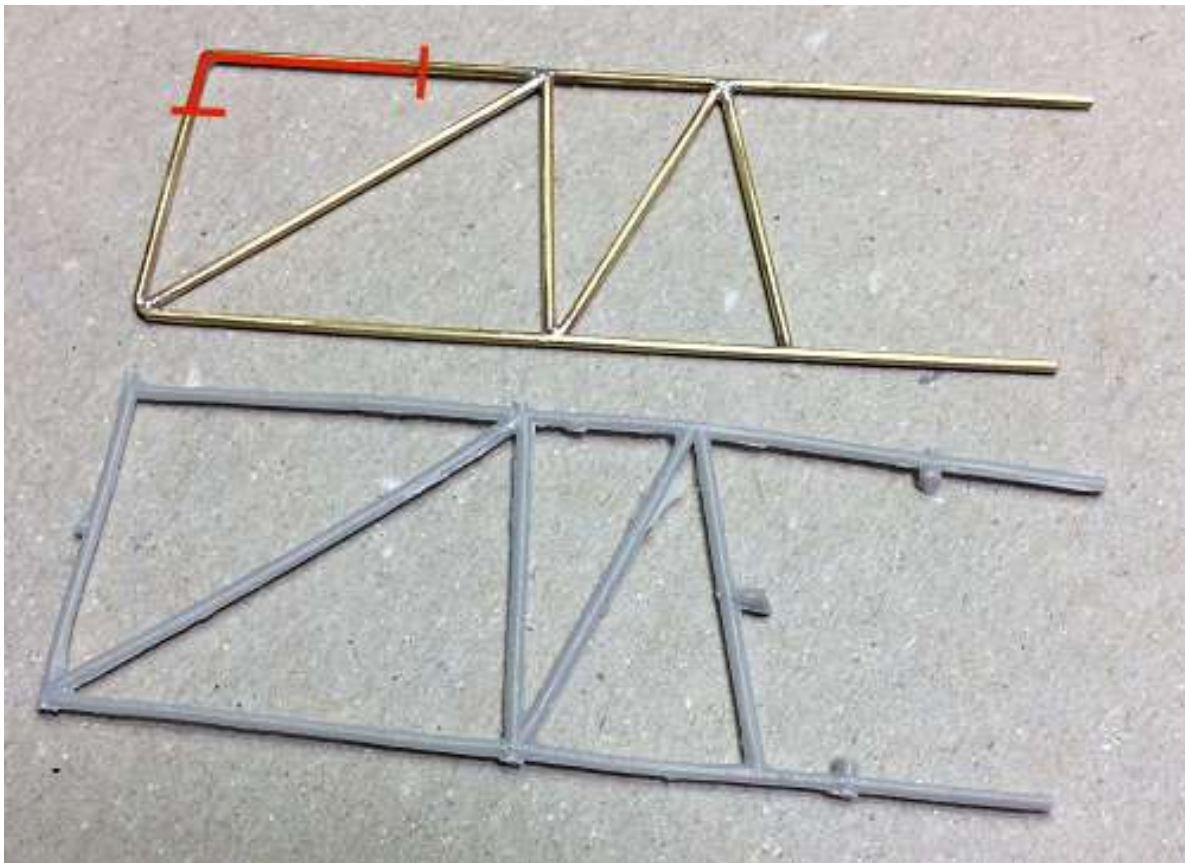

Gun support cross bar

The gun support cross bar in the kit is weak so I discarded it and instead added a length of 1.0mm diameter brass micro-tube to span between the cockpit side frames (once the fuselage halves were closed up) and at the correct position to align with the vertical support bars that were added to the breech of each machine gun (refer to Part 6 of this build log).

Controls:

The right side cockpit frame requires a magneto starter and a fuel pump, neither of which are supplied in the kit.

I fitted a magneto starter from my 'spares box, although one can be assembled from the photo-etch Part No.32028 Fokker DR.1 (1/32), if you have it.

The fuel pump was constructed from brass micro-tube (Albion Alloys):

I cut x3 short lengths of 1.0 mm diameter tube for the fuel pump frame fittings.

I cut 1 slightly longer lengths of 1.0 mm diameter tube for the end fitting (at handle).

I cut a single length of 0.8 mm diameter tube for the fuel pump body.

I cut a short length of 0.4 mm diameter tube for the pump handle stem.

I cut a very short length of 0.3 mm diameter tube for the handle.

NOTE: Thin CA adhesive was used to secure all items.

The 3 frame fitting tubes (1.0 mm) were positioned onto the tube (0.8 mm) for the fuel pump body and to align with the cockpit frame cross pieces. They were then secured to the cockpit frame. The longer end fitting tube (1.0 mm) was secured to the handle end of the fuel pump body (ensure the adhesive is only applied to the tube at the end opposite to the handle). The tube for the pump handle stem (0.4 mm) was then secured into the fuel pump body. Finally the tube for the handle (0.3 mm) was secured across the pump handle stem.

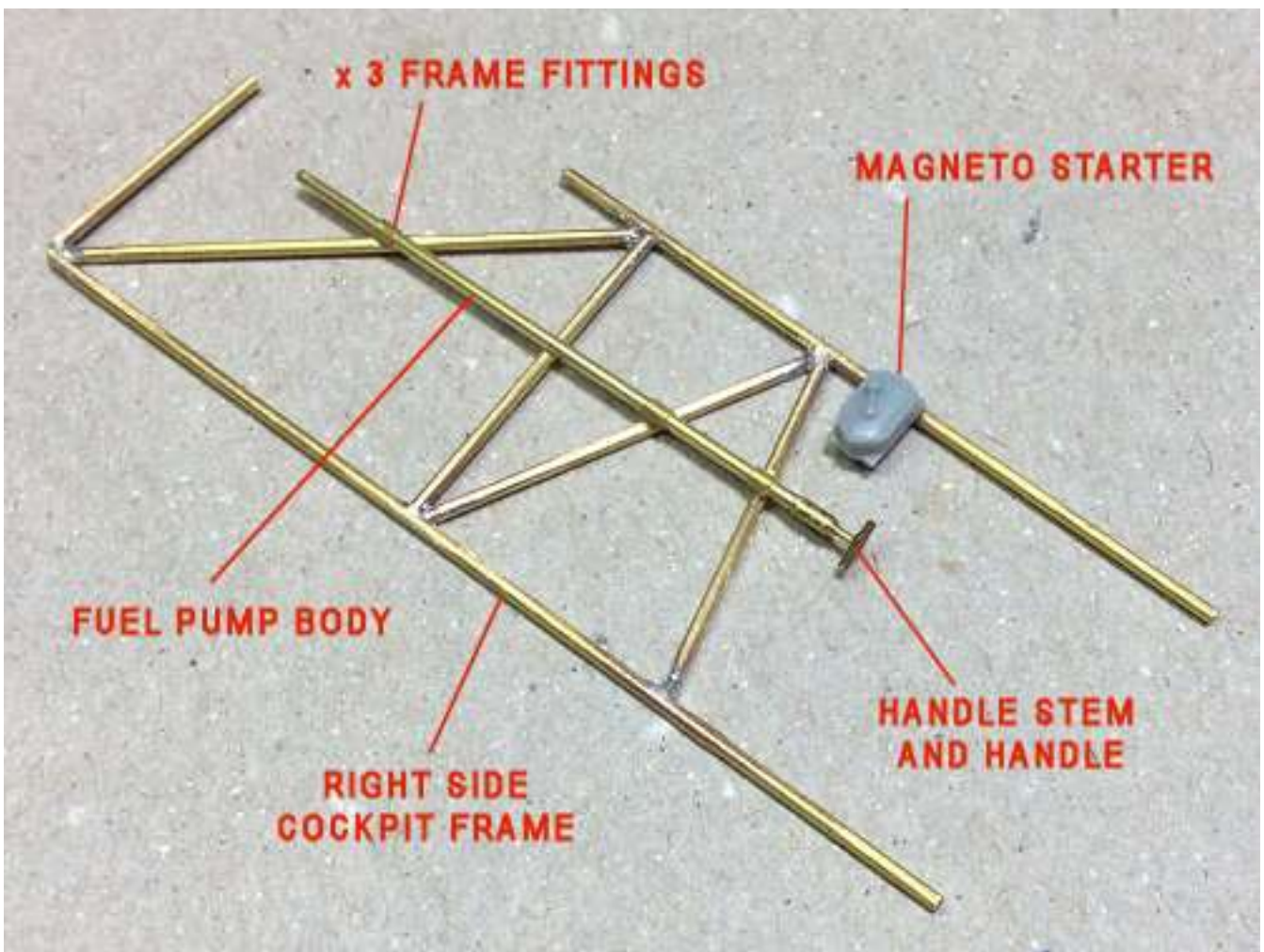

The left cockpit frame requires a better throttle quadrant than that supplied in the kit, as well as a switch, fuel and throttle control runs, which are not supplied in the kit.

Below is a Fokker typical control layout, even though that illustrated is for the Fokker DR.1 tri-plane.

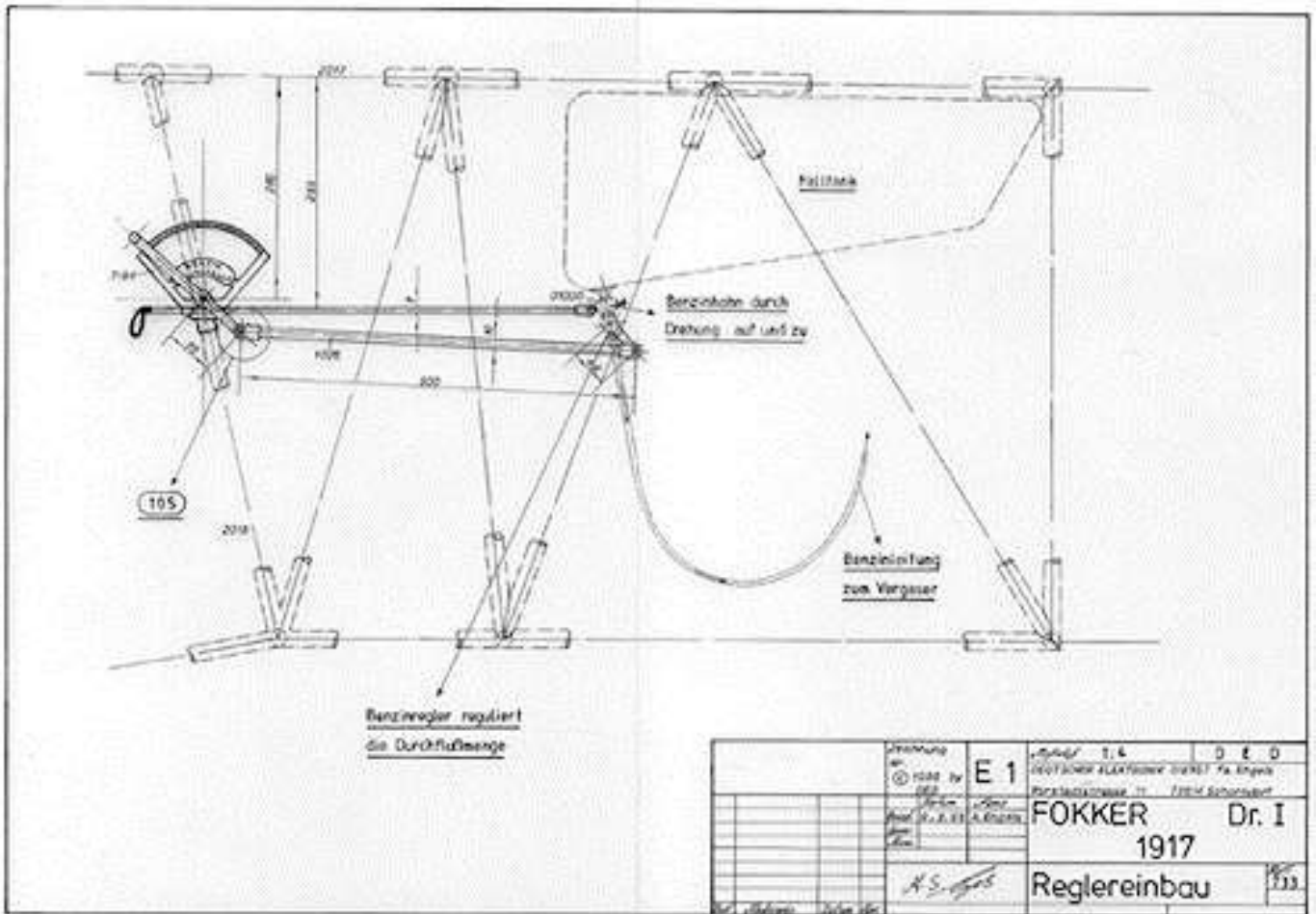

The cockpit magneto switch (Bosch) and throttle quadrant were constructed from the photo-etch items on the Part No.32028 Fokker DR.1 (1/32), if you have it.

The fuel control run was made, in a similar fashion, to that for the fuel pump detailed for previously for the left cockpit frame, except the tubes used were 0.7 mm diameter for the frame fixing and control end piece. The operating 'loop' was made by looping 0.125 copper wire around a 0.5 mm diameter tube or drill and twisting to form a tail, which was then secured into the open end of the end piece.

The throttle control run was made from 1.0 mm diameter brass tube for the three frame fittings and 0.8 mm diameter tube for the control run.

After the two control runs were secured in position, the photo-etch throttle quadrant was secured in position over both.

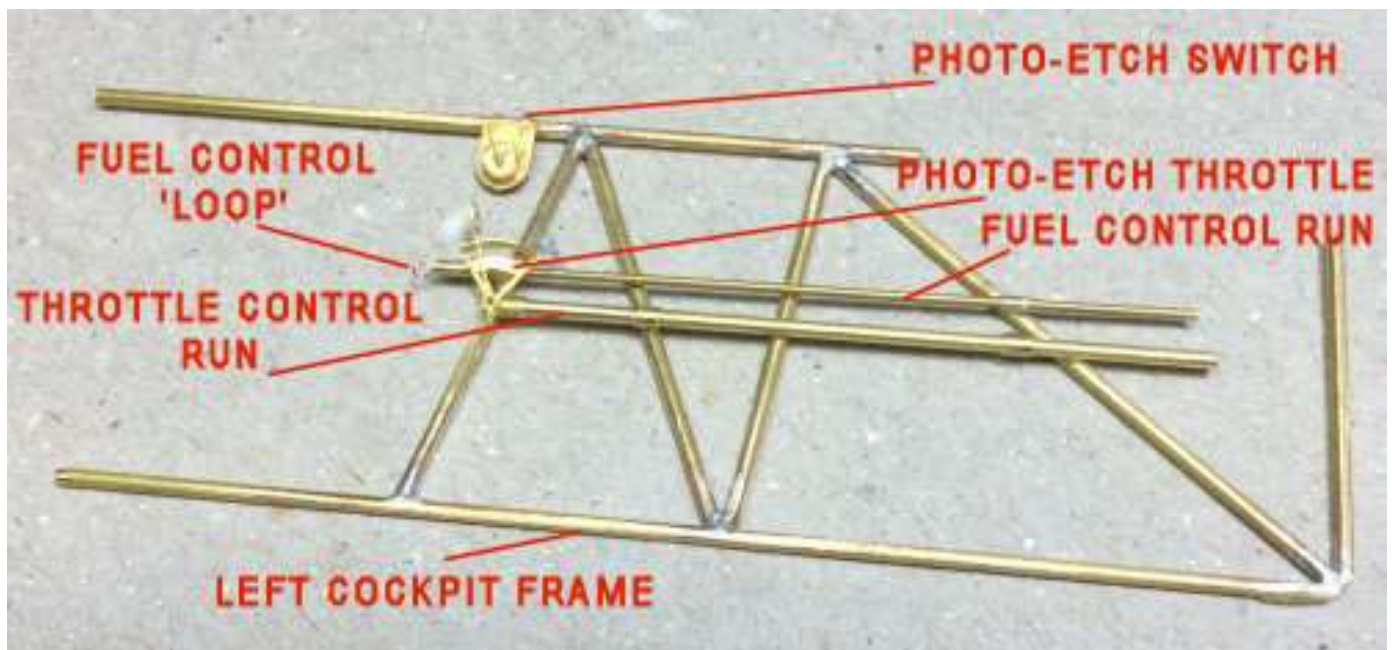

The following photograph shows a typical Fokker cockpit. Note the two cables for the gun synchronisation cables running from the guns, to the control column and then onto the rear of the engine. These were replicated using lead wire.

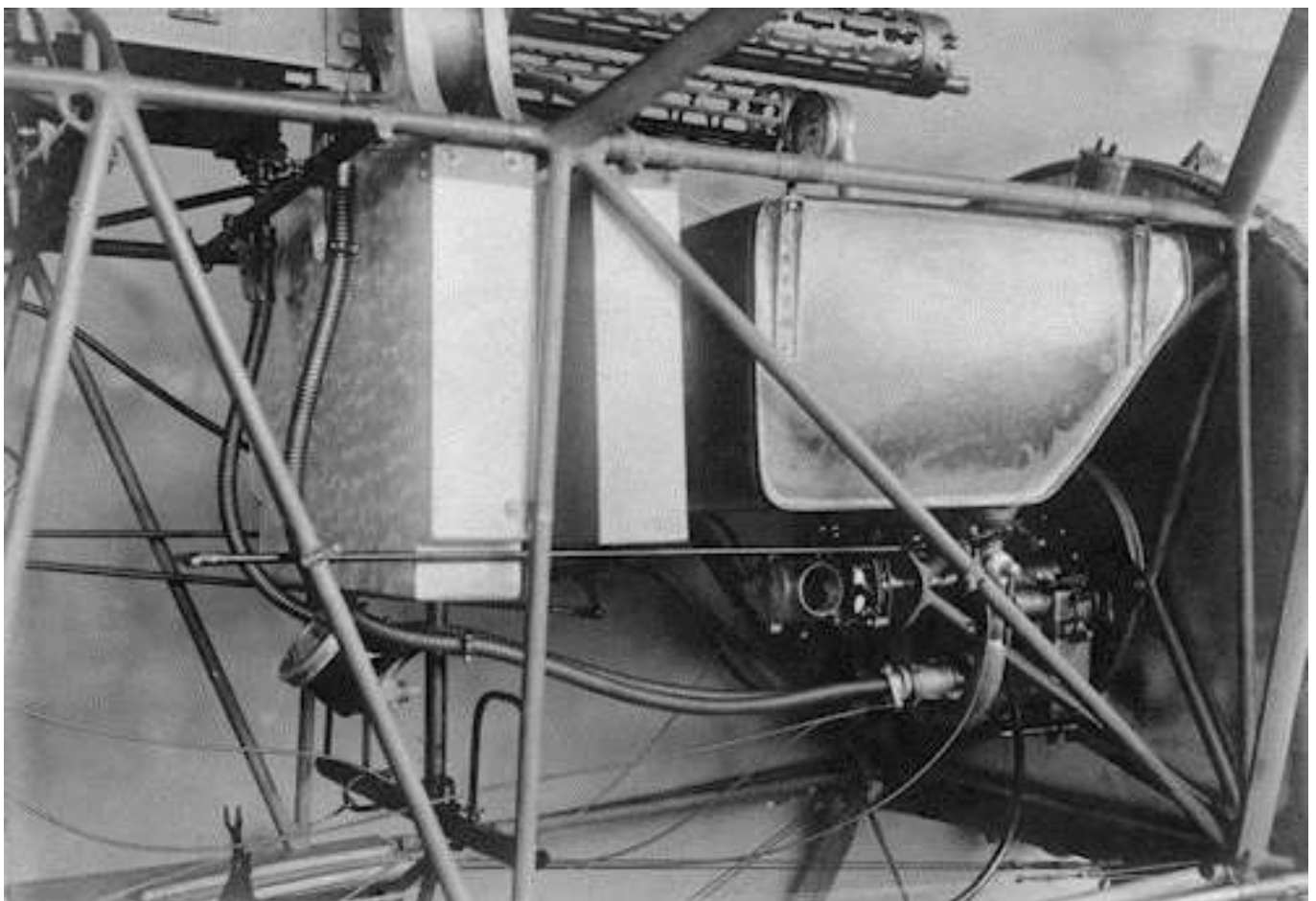

If you intend to show the finished aircraft model with ailerons and/or elevator in anything but the neutral position, the controls will need to be positioned correctly, as shown in this typical Fokker cockpit diagram.

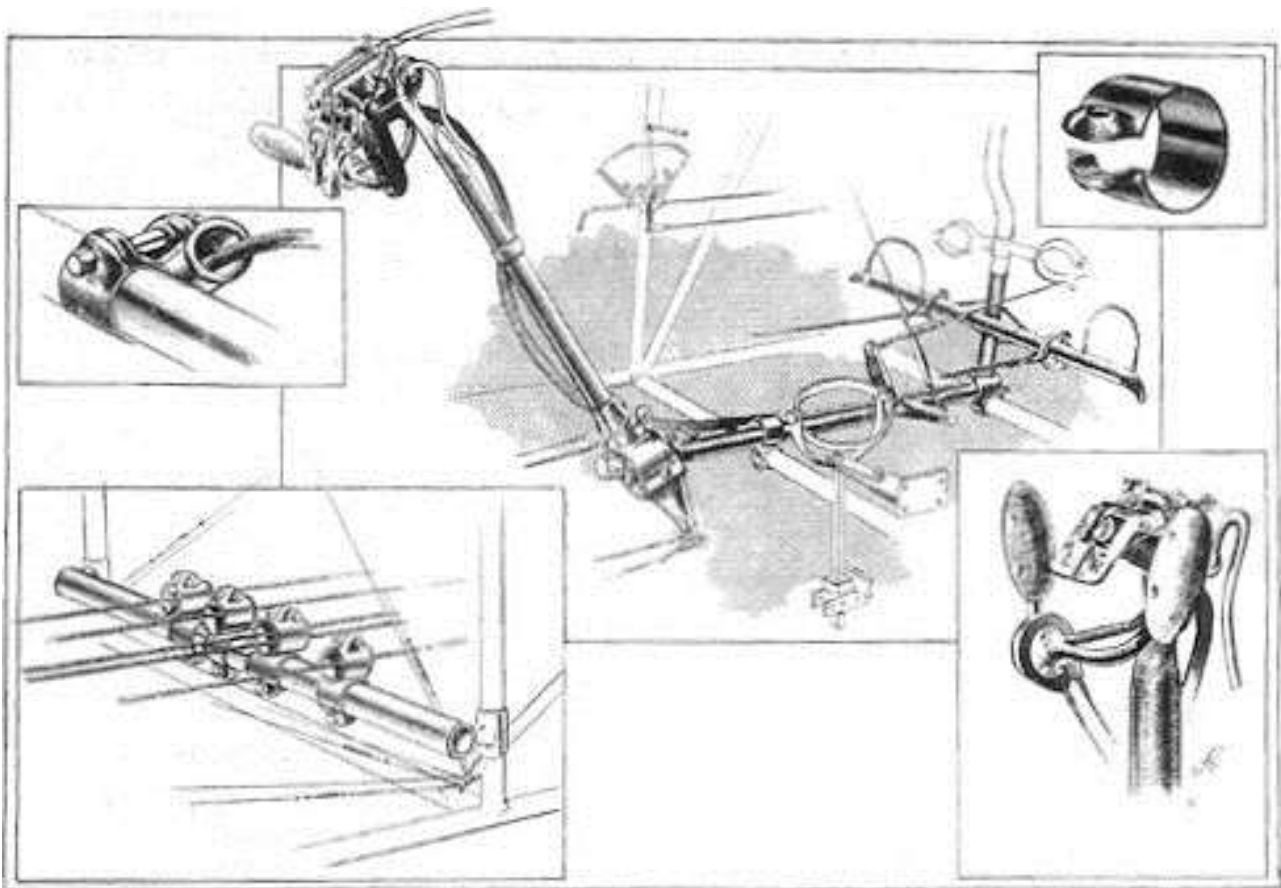

Seat/seat frame/seat belts:

Seat/Seat frame:

The kit supplied cockpit seat is not really to true scale and not the correct shape for later Fokker aircraft, in which the seats were more flared at the waist. To rectify this I used the resin Fokker seat from 'Aviatic' (ATTRES 022), which also has a resin seat cushion.

The kit supplied seat frame was again not really the correct scale so instead, I made the frame using 'Albion Alloy' brass micro-tube MBT08 (0.8 mm diameter with 0.6 mm internal bore) and MBT06 (0.6 mm diameter) for the frame joints (*refer to the drawing on the following page*).

First the seat back frame was drilled, using a 0.7mm diameter drill, in each of the four corners where the seat frame would be located (*refer to drawing above*).

Then a length of MBT08 tube was cut to the width of the front of the seat (see above drawing) and secured in position using thin CA adhesive, to represent the seat support bar.

The seat was then temporarily held in position on the seat back frame with 'UHU White Tack'.

The MBT08 tubing was cut to the appropriate lengths and for the side frames. Then the MBT06 tube was cut into short lengths and secured into the ends of the MBT08 tube using thin CA adhesive. The MBT06 'joints' were then bent to shape and align the two v-shaped side frames to the seat and the seat back frame. Then the MBT06 tube ends of the two frames were located into the pre-drilled holes in the seat back frame and the side frames aligned to the seat. The four MBT06 ends were then secured using thin CA adhesive.

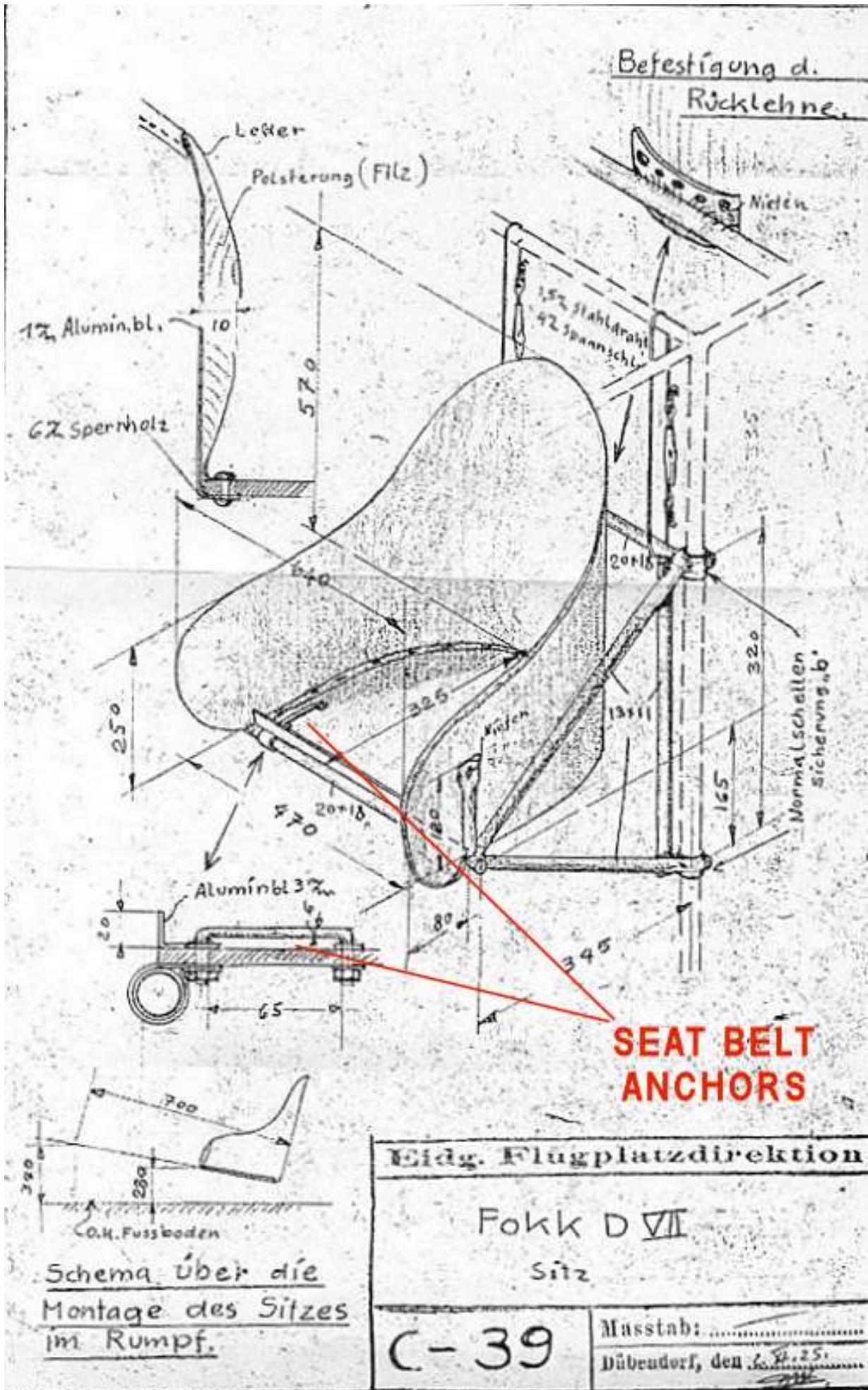

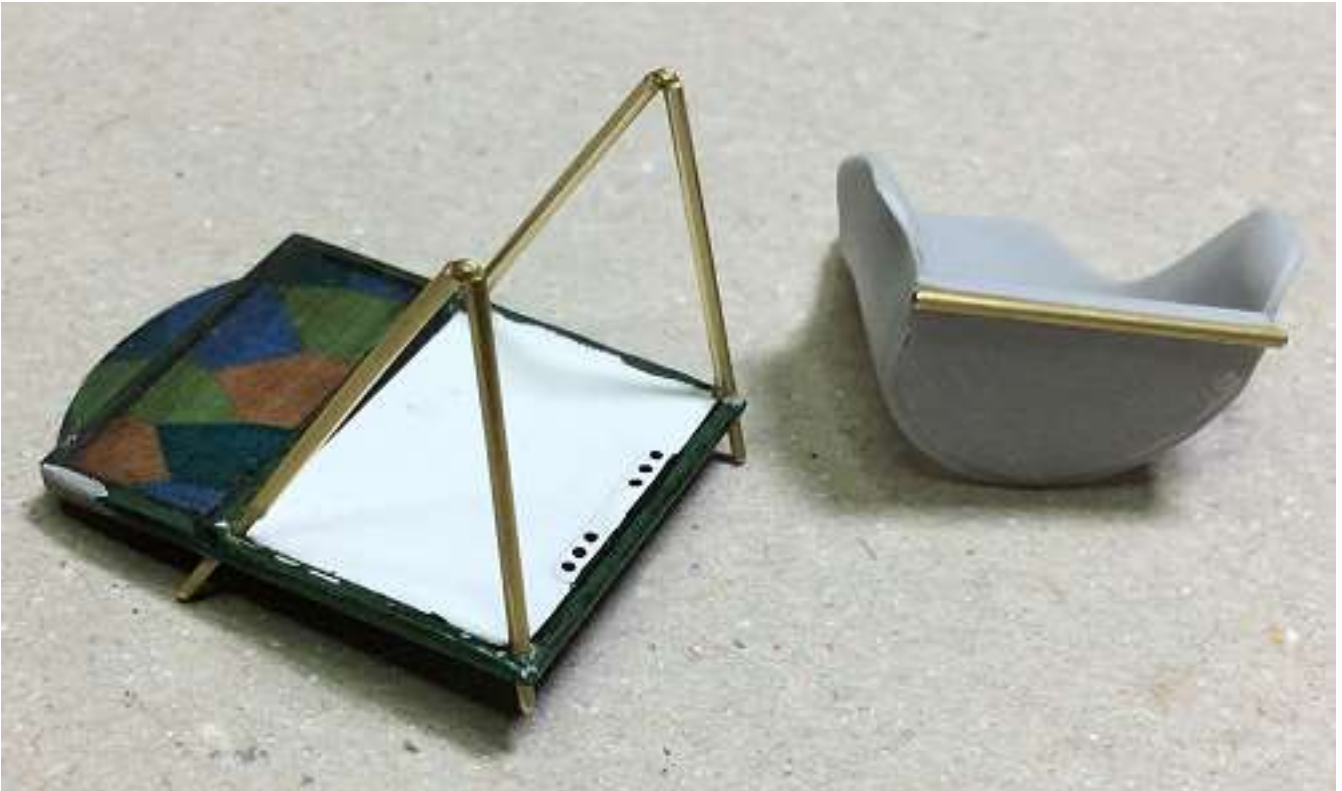

The protruding lengths of MBT06 at the rear of the seat back frame were cut, then sanded flush. Two lengths of MBT08 were cut for the vertical supports and secured in position using thin CA adhesive (ensure a small gap remains behind to allow applying the lozenge decal). Two small lengths of MBT08 were cut and flattened at one end with flat nosed pliers. The opposite ends were sanded at an angle. These were secured onto the sides of the seat to represent the forward seat fittings. Two very short length of MBT08 were cut and attached to the outsides of the seat frames, at the forward 'V'. The represent the protruding ends of the seat support bar. Once set, the seat can be removed from the frame.



Remember to drill through the 6 control cables holes at the base of the seat frame.

The end result gives a fair representation of the later designed seat support frame for Fokker aircraft.

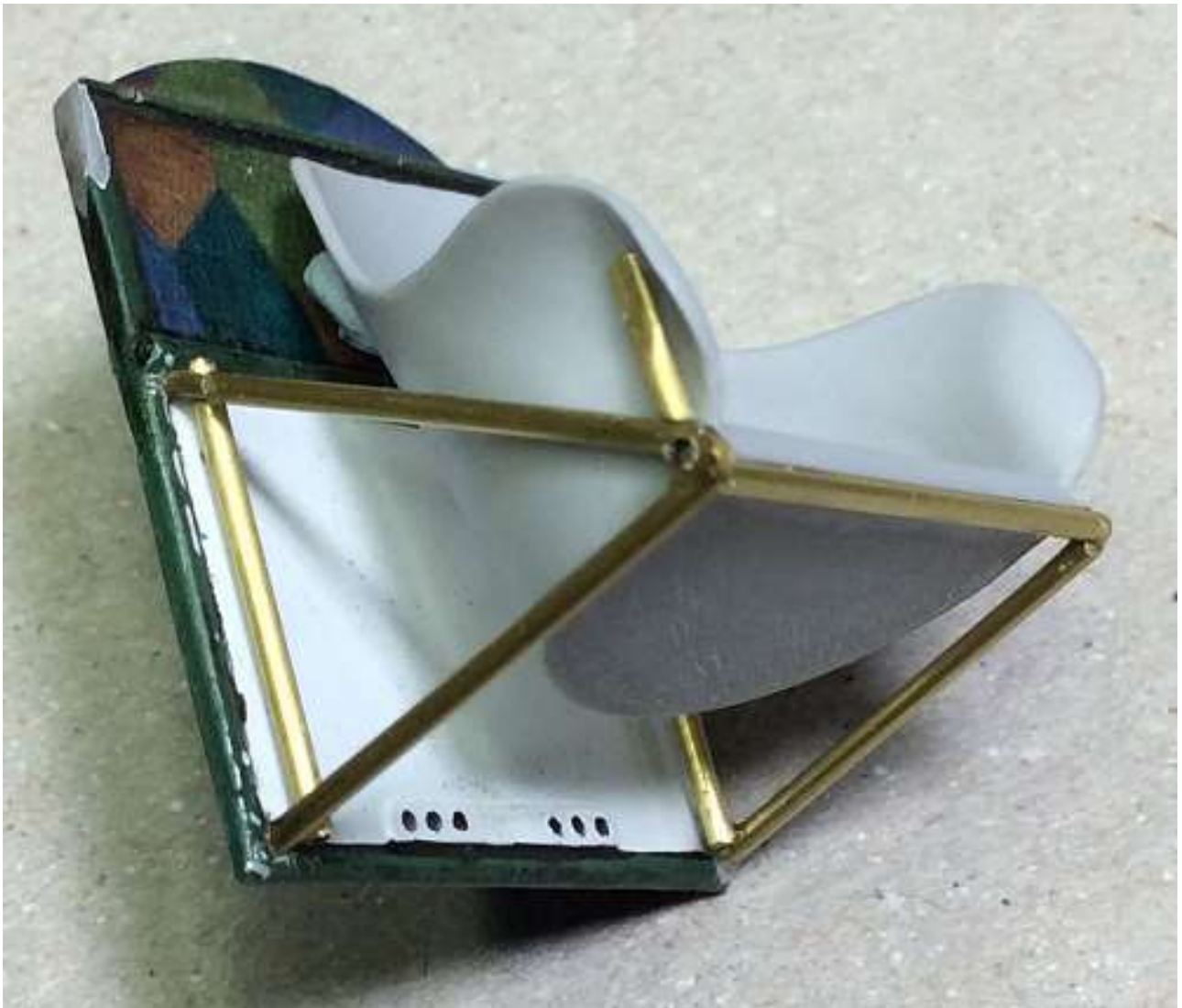

Seat Belts:

The kit supplied brass photo-etch belts were used, suitably softened over a flame and cleaned before painting.

Shoulder belts:

Fokker shoulder belts were wrapped around the upper, rear cockpit fuselage cross tube frame member and returned over the pilot's shoulders to attach to the two seat belts, interlocked and secured using the a locking pin.

Lap belts:

The two most common methods of attaching lap belts were:

1. The lap belts are anchored to each inside of the seat and seat frame with pass-through bolts.
2. The lap belt is attached to the top of the wooden base of the seat, using two brackets, which were attached with bolts and nuts. These brackets anchor the two seatbelts and are covered by the seat pad (*refer to previous seat drawing*).

LAP STRAPS (MODERN REPLICA)



ORIGINAL SEAT STRAPS



Compass deviation chart:

I printed a compass deviation chart and secured it in position, on the lower left of the front ammunition box (closest to the pilot), by locating it on freshly airbrush Alclad Light Sheen (ALC-311) lacquer.



Back screen:

The actual aircraft had a linen 'screen' at the top of the seat frame, through which the two shoulder seat belts were fitted. I used a circular cutter to make a disc of the correct size then cut off the portion required. Slots were cut for the shoulder seat straps, over which I added the 'Aviatic' lozenge decal, matching that on the seat frame linen.

The photo below shows a typical back screen, as used on a Fokker DR.1 Triplane.

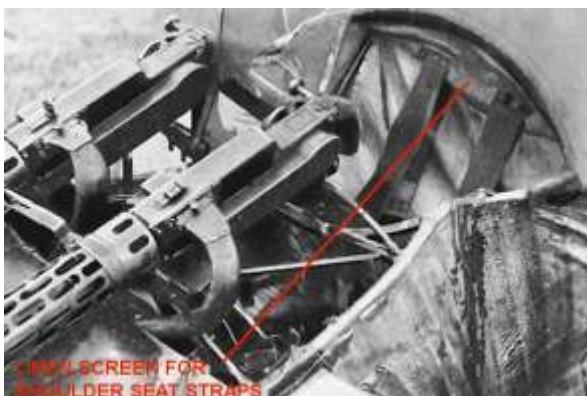

Fuel/Oil tank:

The aircraft fuel tank, as supplied in the kit, has the fuel filler on the forward, left side of the tank. However, there should be an oil filler on the right side.

I drilled a hole through the forward fuselage upper decking for this filler and used the extra item on the duplicate parts sprue in the kit.

NOTE: The actual fuel/oil tank was not fitted to the model as it could not be seen and was causing fit issues between the joined fuselage halves and top decking.



The photo below shows a typical Fokker style fuel/oil tank for the period.



Ammunition containers (tanks):

The kit supplied ammunition containers did not fit between the hand made cockpit sides frames. This required the sides of the containers to be reduced until they were able to fit between the frames. As such the containers were free to move forwards and backwards on the single and weal support bar. To hold the containers in the correct position and to prevent the support bar breaking, a length of 0.8 mm diameter brass rod was fitted at the side frames to span across the forward cockpit and secured in position using thin CA adhesive. Then the containers were the clamped to the brass rod and secured with PVA adhesive (white glue) until fully dry. The rod was then primed and painted to match the cockpit framing colour.

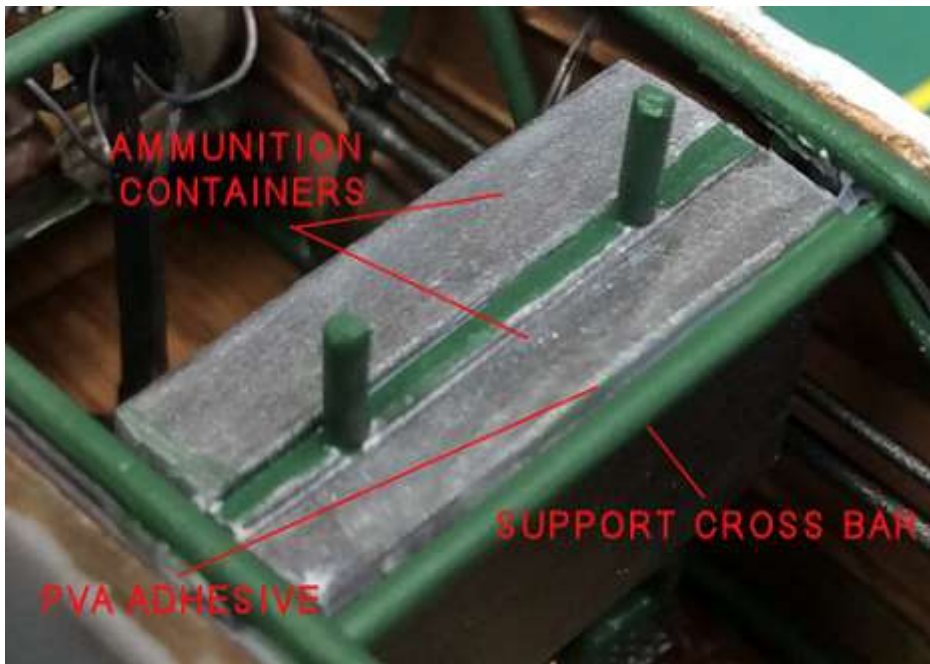

Gun support bar:

I replaced the kit supplied gun support bar with one made from 0.8mm brass micro-tube. A length was cut to fit between the fuselage side frames and positioned such that it was below the cockpit decking apertures, where the two machine gun breeches will be located. The tube was secured in position using thin CA adhesive was then primed and painted to match the cockpit framing colour.

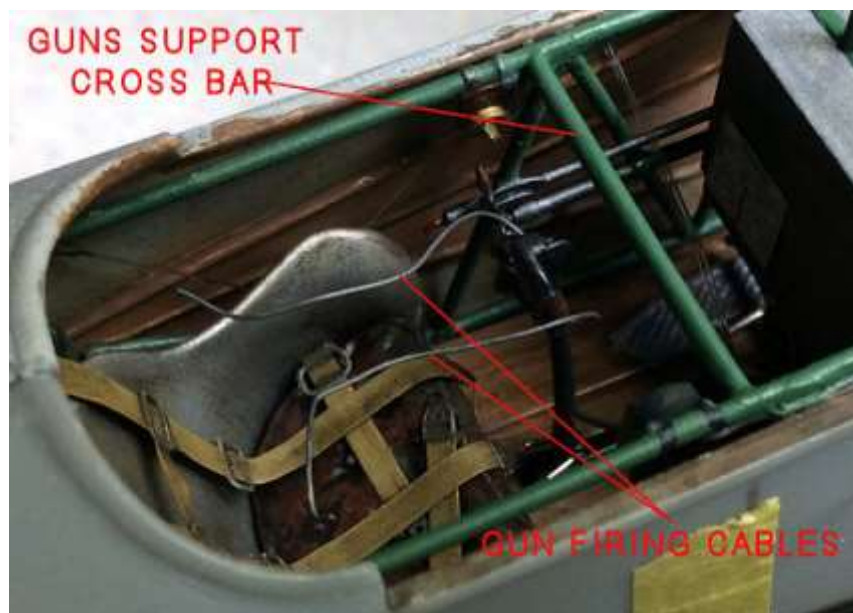

PART 2 - THE COCKPIT

Some modellers work the various pieces whilst they are still attached to the main sprue, but I prefer to remove the pieces first so that I can clean them up more easily. However pieces, such as cockpit framework are delicate and can easily be damaged when being removed. If you cut them off with snips, scissors or a blade etc, they can either break or get stressed at the cut point, which causes 'white' stress and/or deforming. I prefer to cut them away using a fine modeller saw, which I find has a more gentle cutting action.

I use a straight edged scalpel blade to gently scrape off the mould lines. Some of the model items, particularly in the cockpit, are very small and can easily 'fly off' when being handled, so take care. Remember to drill any holes needed for rigging or control lines (study the kit rigging by reference to the kit diagram or other data).

The items, before being removed from the sprue and prepared, should be gently washed in warm, soapy water, to remove any mould release agent remaining on the items. I use an old toothbrush to do this. Once dry they can be primed ready for painting. Primer can be applied by brush, airbrush or from aerosol cans. Although not the cheapest method to prime items, I prefer to use Tamiya's fine surface primer aerosol (light grey). It has good coverage as the base primer for acrylic painting. Take care when spraying the primer as applying too much will result in 'pooling' or 'runs', which would then need to be removed once the primer has dried. Make sure you spray in a well ventilated area or, if you have one, use an extractor booth.

To hold items for priming I use self locking tweezers or carefully insert a toothpick into the item. To hold small items I use a small piece of sticky putty, such as 'Blu Tack', on the end of a tooth pick. Once applied the primer dries quickly, one of the main advantages of using acrylic paints. rather than enamels etc.

Wood Effect:

NOTE: Tamiya Acrylic paints used, unless stated otherwise

The only major item of this model that requires a wood finish is the cockpit floor. The only other wood items inside the cockpit are the plywood side fairings and these will be covered using the decals in the 'Aviatic' decal set (Aviatic (ATT32115) 1:32 scale Fokker D.V/D.VIII 4 colour lozenge decals). Once the primer is dry, you can start applying the wood effect to the cockpit floor.

To start, apply a suitable base colour. For most painting I use an airbrush and only resort to brush painting when dealing with small items. For this build I used Tamiya Buff (XF67), suitable thinned with Thinners (X20A). Allow this base coat to fully dry (if you can't smell the paint, then it's dry).

For the next step I use DecoArt Crafters Acrylic (water based), Burnt Umber, which is similar to Acrylic oil paint, but instead of being oil based, is instead water based. This paint is not as thick as oil based paint and is more creamy, so can be brushed and controlled more easily. Also, as it is water based, it's easy to clean your brushes, and if really necessary, can be thinned slightly with water. Also it dries as quickly as normal Acrylic paint, instead of taking days, which is a disadvantage of using true Oil Paints.

Place a small amount of the oil paint onto a non-absorbent surface and using a suitable oil paint brush (I use a slightly curved brush), wipe a small amount of the paint onto the brush. Apply the paint to the applicable item, using light strokes and in the required direction (e.g. along a wing strut, not across the strut). Only apply a light coat as a second coat, if required, can be applied once the first coat has dried (I applied a second light coat for these items).

I apply the paint along the item and if you apply too much paint, just brush it off before it dries. Don't try to thin any applied paint with water as although it will lift the paint, it will build it up into clumps. Clean the brush in water.

Once the oil paint layers have dried, the final top coats can be applied to give the final effect of varnished wood. In this case the Alclad Light Sheen (ALC-311).

The Alclad dries fast and provides a good sealing layer over the painted surfaces. When using Alclad sealing coats, the golden rule is to allow the various painted surfaces to dry fully before applying Alclad lacquers. The first coat dries may dry to a more matte finish, which I assume is due to being sprayed onto the Oil paint, rather than onto straight Acrylic paint. Once this coat has dried, I airbrushed a second coat which will give the desired semi-gloss 'varnished' finish I was after.

Once the last layer of airbrushed Alclad Light Sheen has dried, you can start to paint the smaller items in the cockpit. These items are brush painted using Tamiya acrylics and Mr. Metal paint. White Spirit is needed to clean brushes used with Mr. Metal paint, as Tamiya's X-20A doesn't touch it. This leads me to believe Mr. Metal paint is enamel based, rather than acrylic.

For small items I brush Mr. Metal paint, rather than airbrush. It can be airbrushed for larger areas, but care is needed to thin the paint correctly, otherwise I've found it can clog the airbrush. Once you have brush painted an item and once it has fully dried, the painted surface can be 'burnished' by gently rubbing the surface with a cotton bud, piece of cloth or even your finger. Doing this merges the pigments of the paint to create a realistic metallic sheen.

To paint the various cockpit items:

Cockpit side and seat frames, Rudder bar, Ammunition tank support - mix of Tamiya Dark Green (XF70) and Cockpit Green (XF71).

Control tubes, Foot plates, Fuel/Oil tank and Ammunition tanks - Mr. Metal Stainless Steel (213).

Cockpit floors - Tamiya Buff (XF67) and DecoArt Crafters Acrylic Oil Burt Umber.

Control column, Compass, Tachometer, Magneto starter - Tamiya NATO Black (XF69)

Starter switch - Mr. Metal Brass (219).

Fuel mixture control handle - Tamiya Red (X7).

Fuel pump and control column handles - Tamiya Hull Red (XF9).

Seat cushion - Tamiya Hull Red (XF9), highlighted by NATO Brown (XF68) with Flory Dark Dirt clay wash.

Seat - Alclad Aluminium (ALC 101) and Flory Dark Dirt clay wash.

Seat straps - Tamiya Dark Yellow (XF60 with Flory Dark Dirt clay wash).

Once dry, all of the cockpit pieces were given a airbrushed sealing coat of either Alclad Light Sheen (ALC-311) or Matte (ALC-214).

Use the normal method of applying the decals to the instruments. When a decal is in position press out any surplus water, using tissue paper or a cotton bud. Once this is done, brush a small amount of MicroSet over the decal surfaces, as this will soften the decals and cause them to 'weld' to the painted surface. Don't be alarmed if the decals wrinkle at first, as this is the MicroSet taking effect and the wrinkles will disappear once dry. Once dry I trimmed the edges before adding photo-etch instrument bezels from Airscale Instrument Bezels (PE32 BEZ).

The cables for the starter switch, magneto starter, instrument, control column and gun firing were made from thin lead wire.

Internal frame rigging and flight control cables were made from 'Steelton' Mono-Filament 0.12 mm diameter, Albion Alloy 0.4 mm Nickel Silver micro-tube and 'Gaspach' Type C (1/48 scale) turnbuckles.

The gun firing and control column cables will be added once the cockpit floor is secured onto the fuselage floor on the left fuselage side assembly. These cables will be created using thin lead wire.

The control cables for the rudder bar and the elevator (at the base of the control column inside of the cockpit) have been secured in position through the base of the seat mounting frame. The elevator cables at the bottom of the control column are outside the fuselage, so will be secured in position later in the build. The twin ailerons cables are secured to the operating bell crank, but will be passed through the fuselage outlets and attached to the underside of the wing later in the build.

The **rudder bar cables** were created by twisting 0.125 mm copper wire around the rudder bar. A 0.4 mm diameter nickel-silver tube was cut and located over the twisted 'tag' of the copper wire. A length of 0.12 mm diameter 'Steelton' mono-filament (fishing line) was inserted into the other end of the tube. Thin CA adhesive was used to secure the assembled parts.

The **twin aileron cables** were created by passing a length of 'Steelton' Mono-Filament 0.12 mm diameter through the pre-drilled holes at each end of the aileron operating bell crank. A short length of 0.5 mm diameter brass tube was then slid onto one line and the other end of the line passed back through the tube. The tube was then slid down to the bell crank and secured using thin CA adhesive, leaving two cable line at each end of the bell crank.

NOTE: The twin cables cross over at the bell crank (e.g. left side to right fuselage outlet).

Twin elevator cables were fitted at the base of the control column (inside the cockpit) and also at the very bottom of the control column, outside the fuselage.

The cables were created by passing a length of 'Steelon' Mono-Filament 0.12 mm diameter through the pre-drilled holes at the two locations on the control column. A short length of 0.4 mm diameter Nickel-Silver tube was then slid onto each line. At each of the two locations the two lines were pulled tight (rearwards) before the tubes were secured using thin CA adhesive, leaving two cable line at each end of the bell crank. This will ensure the line and four tubes are orientated rearwards to the elevator.

Below is a shot of the cockpit floor assembly with the control cables added - the cable end fitting tubes will be painted before the fuselage is closed up.

NOTE: The Compass deviation chart, Tachometer and Compass decals and photo-etch brass instrument surrounds have been applied.

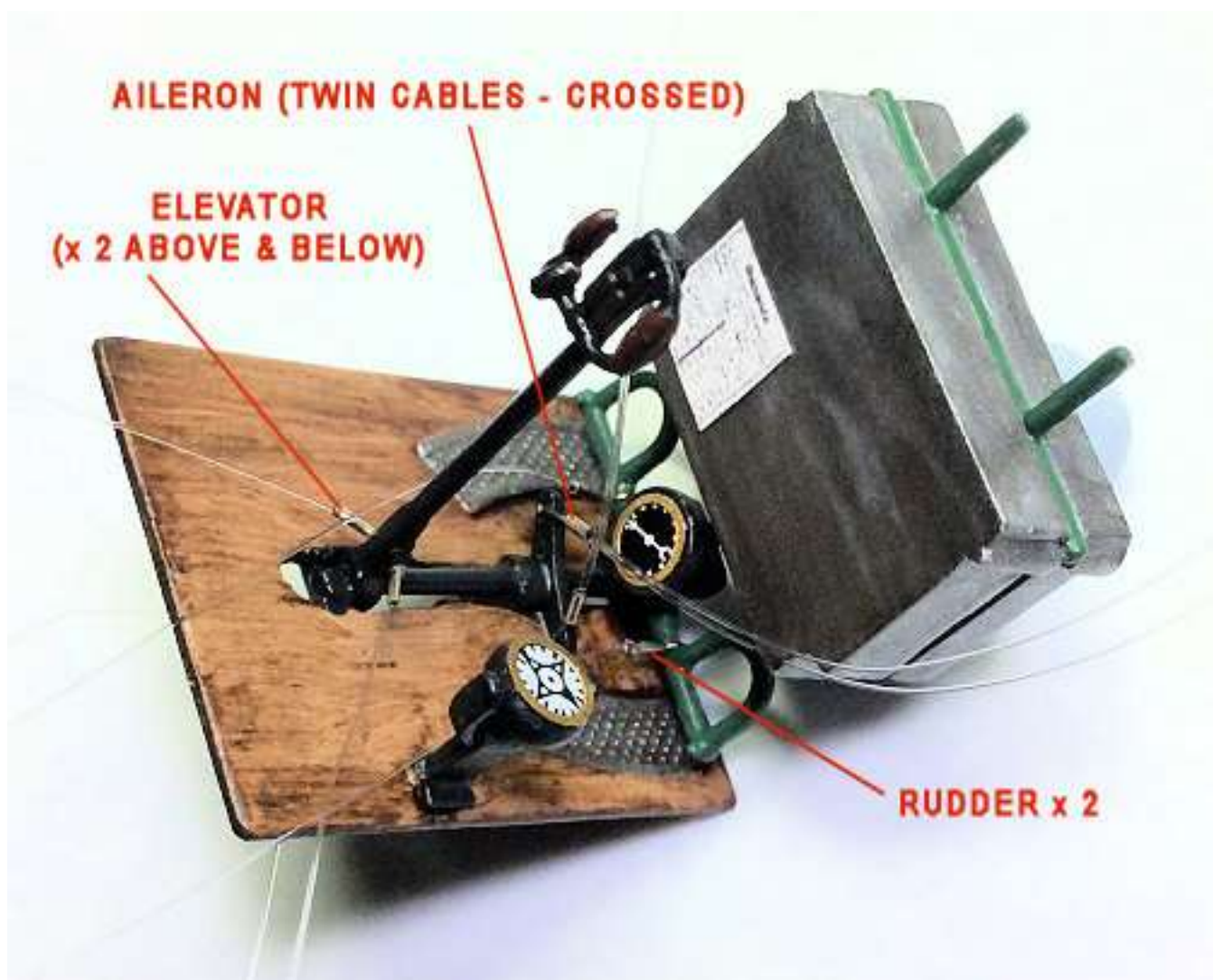

Below are shots of the cockpit side frames. The crossed bracing rigging was made from Steelon mono-filament, Gaspatch 1:48th scale turnbuckles and Albion Alloy 0.4mm diameter Nickel-Silver tube. Instrument cables were made using thin lead wire. The frames were a solder constructed from 0.8mm diameter brass tubing from Albion Alloys.



Below is a shot of the complete seat assembly.



WARNING:

When the cockpit is completed and the fuselage halves are closed up, the lower end of the control column passes through the underneath of the fuselage. This part of the control column has the lower external elevator control cables attached as it is extremely easy to damage this when handling the model whilst continuing with the build.

I temporarily protected this using two pieces each side of the control and held in position with masking tape.



The following shots are of the fuselage halves, immediately after being closed up. The cockpit is not yet complete as gun synchronisation cables, fitted to the breech of each machine gun, will be fitted with the guns later in the build.

Rear of cockpit: - In the following shot are:

1. Just visible the fabric 'back screen' above the top horizontal seat support frame.
2. The cockpit side frames made from brass micro-tube.
3. Some of the bracing rigging on the cockpit side frames.
4. Replacement Fokker type resin seat from 'Aviatic'.
5. The thin lead wires representing the gun firing cables (to be final fitted after guns fit).
6. The cables running down the control column.
7. Gun support cross bar.
8. Ammunition containers cross bar.
9. Photo-etch seat shoulder harness and lap straps.



Port (left) side of cockpit: - In the following shot are:

1. The cockpit side frames made from brass micro-tube.
2. Some of the bracing rigging on the cockpit side frames.
3. Replacement Fokker type resin seat from 'Aviatic'.
4. The thin lead wires representing the gun firing cables (to be final fitted after guns fit).
5. Gun support cross bar.
6. Photo-etch seat shoulder harness and lap straps.
7. Switch and throttle and fuel cock controls.

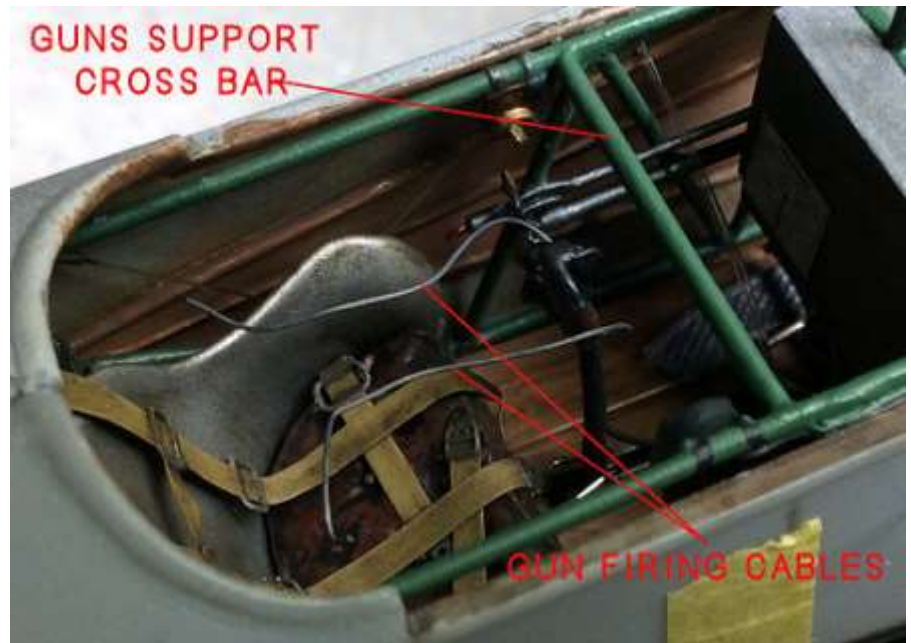

Starboard (right) side of cockpit: - In the following shot are:

1. The cockpit side frames made from brass micro-tube.
2. Some of the bracing rigging on the cockpit side frames.
3. Replacement Fokker type resin seat from 'Aviatic'.
4. The thin lead wires representing the gun firing cables (to be final fitted after guns fit).
5. Gun support cross bar.
6. Photo-etch seat shoulder harness and lap straps.
7. Photo-etch foot plates.
8. Magneto starter and fuel pressure pump controls.



Forward of cockpit: - In the following shot are:

1. The cockpit side frames made from brass micro-tube.
2. Twin aileron control cables.
3. Rudder control cables.
4. Elevator control cables (internal).
5. Replacement Fokker type resin seat from 'Aviatic'.
6. The thin lead wires representing the gun firing cables (to be final fitted after guns fit).
7. Gun support cross bar.
8. Ammunition containers cross bar.
9. Photo-etch seat shoulder harness and lap straps.
10. Photo-etch foot plates.
11. Printed compass deviation chart.
12. Photo-etch surround on compass.
13. Tachometer (just visible at the rudder bar).

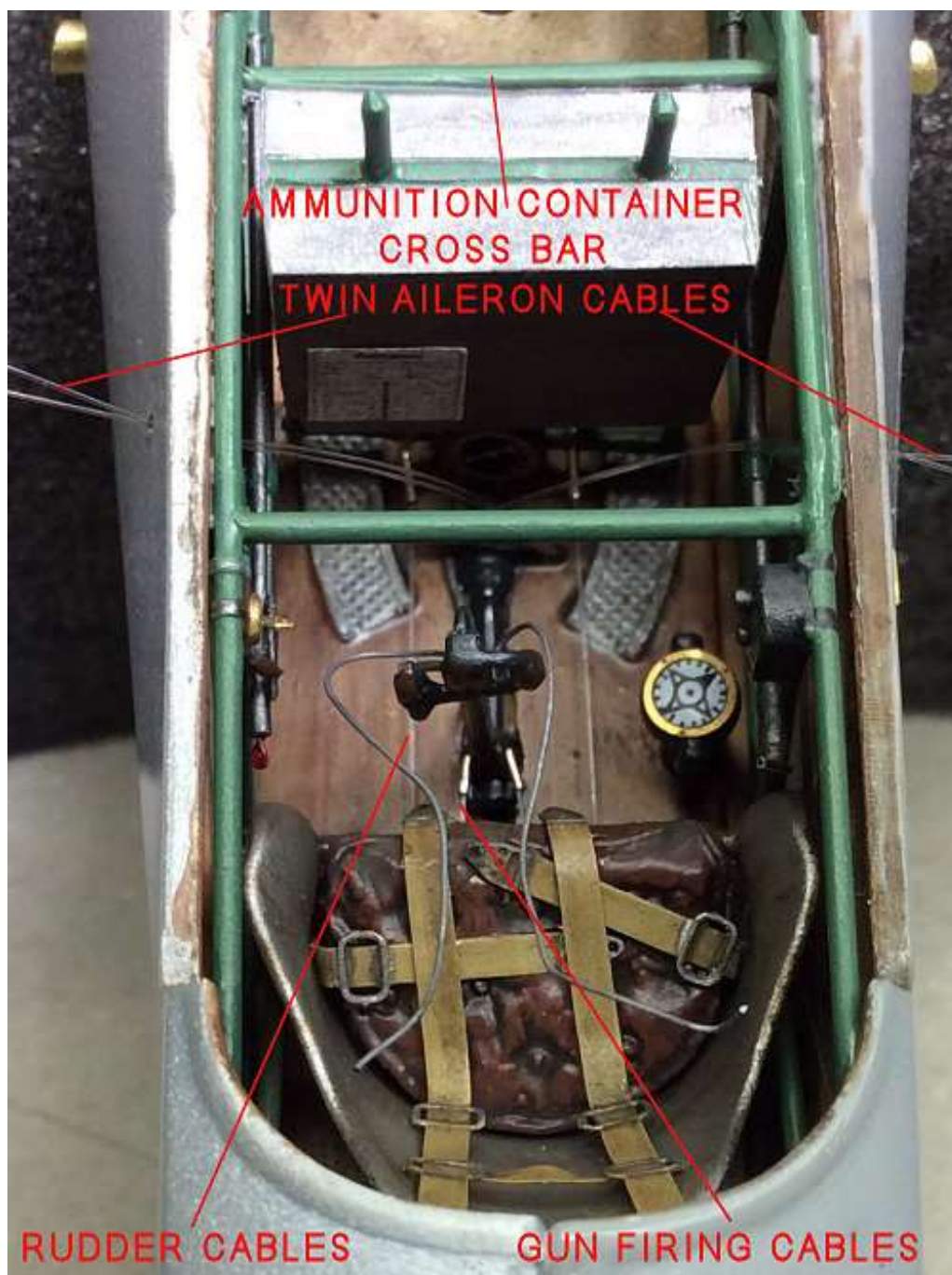

PART 3 - THE FUSELAGE INTERNALS

As with most colouring for World War One aircraft, it's debatable as to the exact colours and tints. New aircraft colours would differ from those that have 'seen service' and age and the ambient conditions would have altered these colours. In addition, the chemical mixture of the various dopes changed throughout the war, due to short supplies of some of the ingredients and the particular aircraft manufacturers take on a particular colour specification. Most colour photographs are of museum aircraft and modern replicas, which may or may not be accurate depictions of the actual colour at the time. The best we as modellers can achieve is what we, as individuals, consider is 'accurate'.

After being primed, I airbrushed Tamiya White (XF2) inside the fuselage. This was to create a white base for the application of the 'Aviatic' wood and lozenge decals. At this stage pre-shading can be applied over panel lines etc, but for this build I decided to 'post-shade' instead. To ensure a smooth finish I over sprayed with Alclad Gloss Lacquer (ALC-310). The plywood side panels and internal lozenge decals were then applied and left overnight to fully dry.



The internal panel wood edges were hand painted with Tamiya NATO Brown (XF68) and the inside face of the engine bulkhead Stainless Steel (Mr. Metal 212) Anything under these decals will show through and given that the paint base coat needs to be of a light colour it means that detail, such as the cockpit framework, will need to be carefully painted, either before or after application of the decals.

Weathering:

Flory Model clay washes come in various shades and consist of a very fine clay pigment. They are brushed over the surface to be weathered and dry in around 30 minutes. When dry, use either a piece of good, absorbent kitchen roll or a brush used for oil paint (as the bristles are harder than normal painting brushes) to remove as much of the clay wash as you need to achieve the desired effect. The damp re-activates the clay wash and allows it to be removed or worked as required.

To apply the clay wash is just a matter of brushing all over the surface to be weathered. It doesn't matter really how much is applied as it can be left on for any period, as it is easily removed without any effect on the surface underneath. The wash I used was a mix of Flory Clay Wash 'Light' and 'Dark Dirt'.

Whatever you use to remove the clay wash, make sure it is only very slightly damp. I dab the brush or absorbent paper onto my tongue, but even then I dab it onto a dry piece of the paper. That's how 'damp' it needs to be. Any wetter and you'll find that you are removing too much of the clay wash. If that happens you would have to re-apply the wash and start again. That said, if you not happy with the final effect, you can easily remove the clay wash by brushing with a wet brush or even airbrush water over the surface. Then you can dry the surface and re-apply the clay wash and try again until you are satisfied. The technique is to brush over the surface to re-activate the clay wash and at the same time, to smear it over areas that had no clay wash. It'll dry more or less straight away.

Then I'll very lightly brush and/or use a piece of damp absorbent paper to remove as much as I want until I get the desired effect. If I remove too much I just reapply clay wash to that area and repeat the removal procedure.

Once finished, just run the brush under a tap to rinse out any residual clay pigments.

If you've not used Flory Clay Washes before, the best thing to do is to experiment first on a test piece. You'll soon get the hang of it.

Along the lower longeron of each side, I dusted Dark Earth pigment, to replicate the oil Staining suffered from the rotary engine.

Once completed, the fuselage halves were given an airbrushed sealing coat of Alclad Light Sheen lacquer (ALC-311).

PART 4 - THE ENGINE

The supplied engine fret is fairly basic and in particular, the engine cylinders are poorly molded and lack definition of the cooling fins.

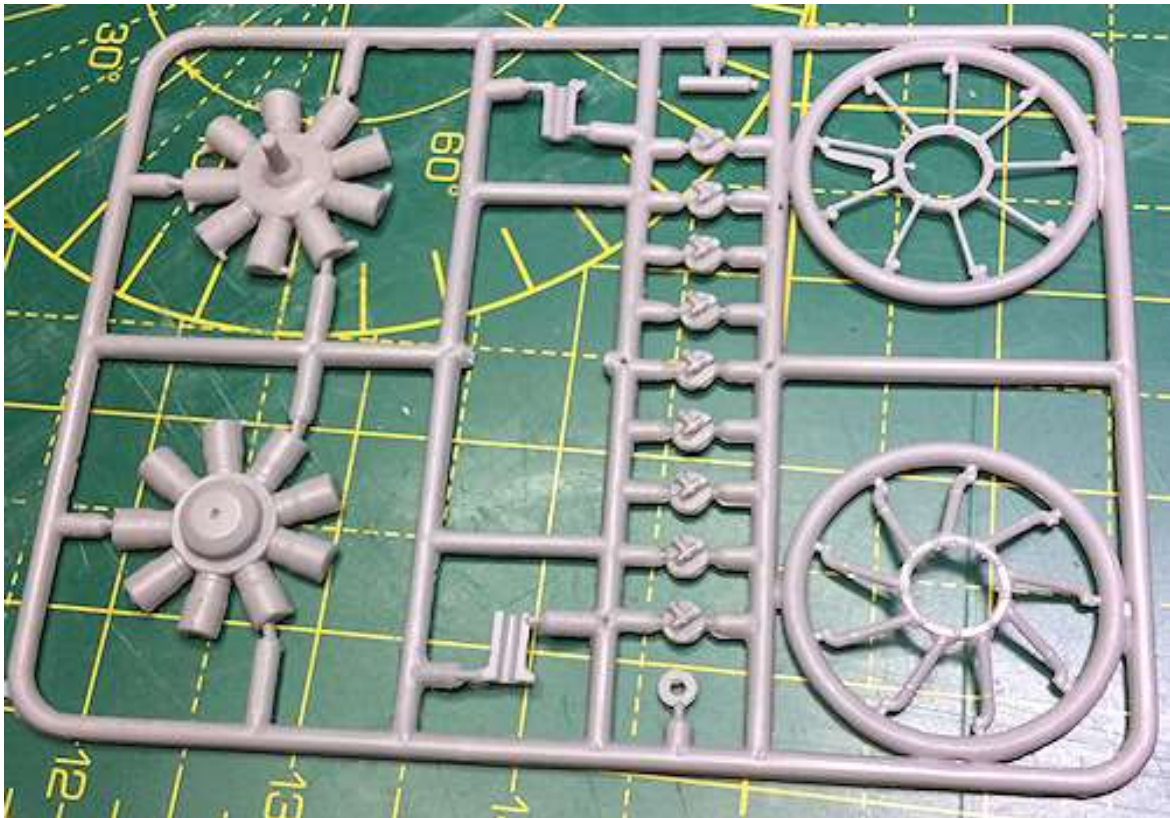

For this build I chose instead to use an aftermarket engine, the Oberusel Ur.II from 'Roden' (kit No. 624), less the supplied guns, propeller and engine stand (now in my spares box).

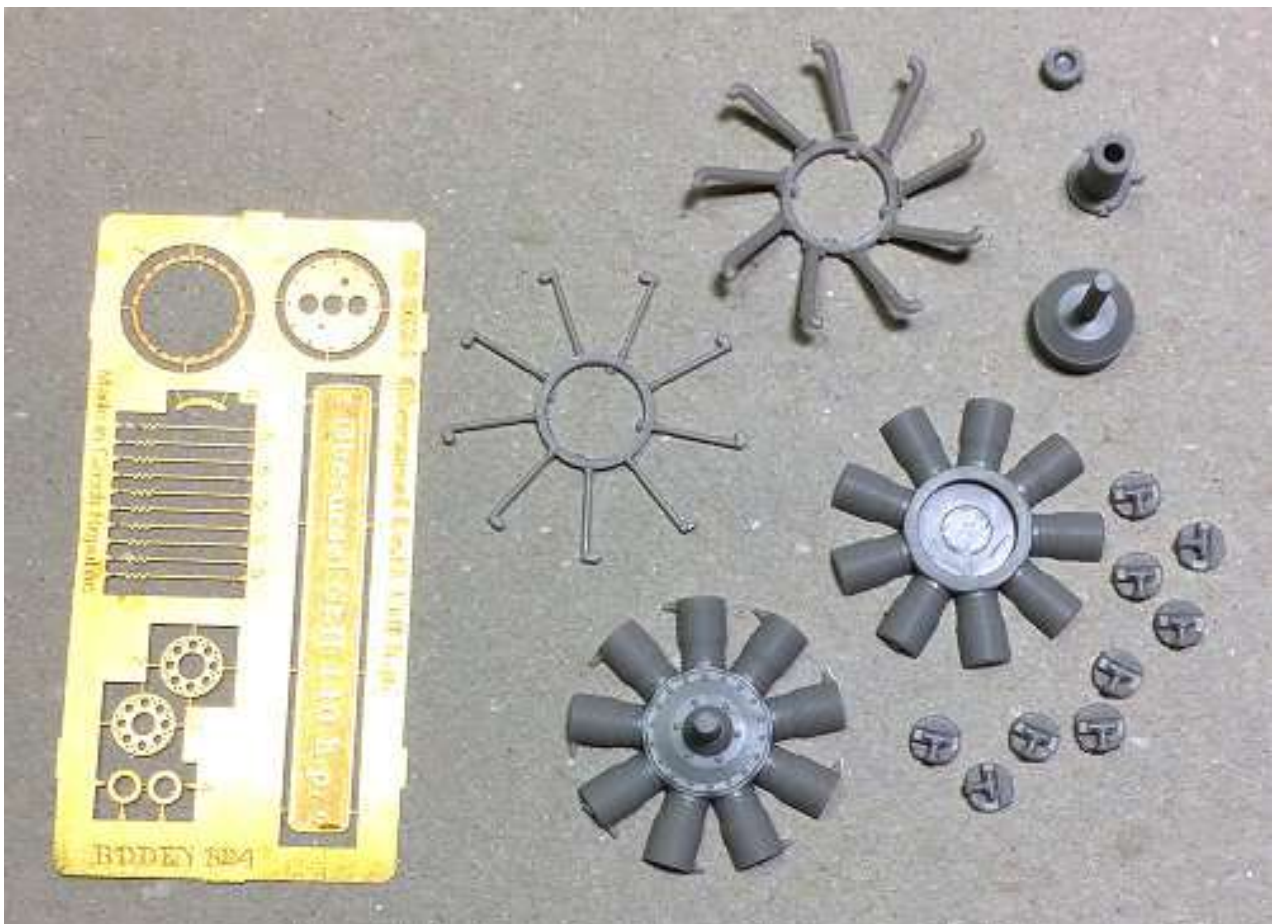

The assembly of the basic engine was carried out following the kit instructions, although the propeller shaft and some cylinder heads were modified (refer to Part 1 - Engine).

1. The engine parts, including photo-etch items, were first primed with Alclad Grey Primer and Micro-filler (ALC-302).
2. The engine assembly was airbrushed with Alclad Gunmetal (ALC-120).
3. The inlet manifold was airbrushed with Alclad Exhaust Manifold (ALC-123).
4. The pushrod ring and rods were airbrushed with Alclad Aluminium (ALC-101).

The engine was then airbrushed with a very light coat of Alclad Aluminium (ALC-101), including the engine crank case. The spark plugs with Tamiya Dark Yellow (XF60). On the inlet manifold and cylinder heads, I applied Tamiya Weathering Set D (Burnt Blue), using a sponge and short, stiff brush, to give a heated effect. The whole engine was then given a wash of AK Interactive 'Leaks and Stains'. The front crank case was then sponged with silver from the Tamiya weathering set C.

The next task is to add the ignition wires from the rear of the engine to each spark plug. To add the ignition leads I cut 9 lengths of 0.125 mm copper wire. Firstly I drilled 0.3 mm holes in the engine rear casing. Each wire was then located in a hole and secured with CA adhesive. The other ends were then pulled around a spark plug and secured using thin CA glue. The excess was cut away using a shielded razor blade. As usual, once the engine is fixed to the forward fuselage bulkhead and the engine cowl is installed, very little of these ignition wires will be seen.

Once completed, the whole engine assembly was sealed by airbrushing a fine coat of Alclad Light Sheen lacquer (ALC-311).



PART 5 - WHEELS

The assembly of the two wheels is straight forward. The outside wheel covers are fitted into the wheel (tyre) recess and secured with Tamiya thin adhesive. The same applies for the inner wheel cover. Aircraft of the period often had patches sewn into the outer wheel covers, to allow access to the inside of the wheel. However on the Fokker E.V, these patches were sewn on the inner wheel covers and as such, are pre-molded on the kit parts.

The outer face of each wheel was primed with Tamiya Fine Grey aerosol primer and the inner faces with Fine White aerosol primer, to act as a base coat for the application of the 'Aviatic' lozenge decals. The outer faces were then airbrushed with a mix of Tamiya Flat Yellow (XF3) 60%, Dark Yellow (XF60) 30% and Flat White (XF2) 10%. The 'Aviatic' lozenge decals are applied to the wheel inner faces later in the build. The tyres were hand painted using Tamiya Royal Light Grey (XF80). Finally I will apply Flory Grime clay wash and when dry, lightly wipe it off to get the desired weathered look and then seal the wheels with airbrushed Alclad Light Sheen (ALC-311).



To airbrush the faces of the wheels without over spraying the painted surrounding tyres, I use a circle drawing tool (Linex 1217 T). I selected the correct size of hole for the wheel only and positioned the wheel face under the hole, temporarily holding it in position using masking tape. Then I airbrushed the required colour through the hole onto the wheel face. This leaves the tyre colour intact. Below is an example of using the Linex 1217 T to airbrush the wheel colour, whilst avoiding overspray onto the painted tyres.

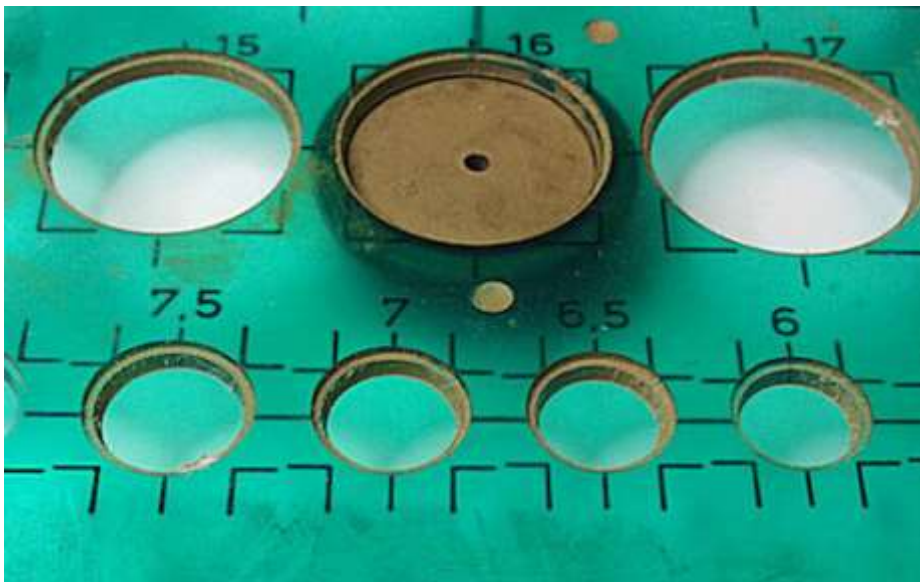

PART 6 - WEAPONS

This aircraft was fitted with two synchronized Spandau LMG 08/15 machine guns, which were belt fed from an ammunition box, located below the guns and in front of the pilot (the box forward of this one was used to store cartridges from the fired rounds).

The guns supplied with the kit are solid and do not represent the open structure of the guns cooling jacket and barrel. They also do not have the ammunition (rounds) counters, that were fitted to the rear of each breech on the guns.

Therefore I decided to replace them with the 'Gaspach' version (14-36021). These have finely cast detail, but need to be handled carefully as it is resin and therefore easy to break off the barrel or smaller parts.



The 'Gaspach' guns were assembled in accordance with the kit instructions, but only the gun barrels needed to be inserted into and through the cooling jackets. The padded head protectors at the rear of each gun breech do not need to be fitted, as the guns breeches did not enter the cockpit area on this aircraft. Instead scratch built rounds counters will be fitted on the rear of each gun breech.

To represent the gun synchronisation cable from each machine gun to the engine, I drilled a 0.7 mm hole in the underside of the gun breech block. A length of 0.5mm diameter lead wire was inserted into the hole and fixed in position with thin CA adhesive.

A 0.8mm diameter hole was also drilled into the bottom of each gun breech and a short length of 0.8mm diameter micro-tube was secured into the holes using thin CA adhesive. These represent the breech supports, which locate onto the cockpit cross bar.

The two rounds counters were created by cutting thin slices from an appropriate diameter piece of spare plastic sprue and attached to the gun breeches using thin CA adhesive. The kit supplied ammunition feed and ejection chutes were used, but did need to be sanded and shaped to fit the Gaspach guns.

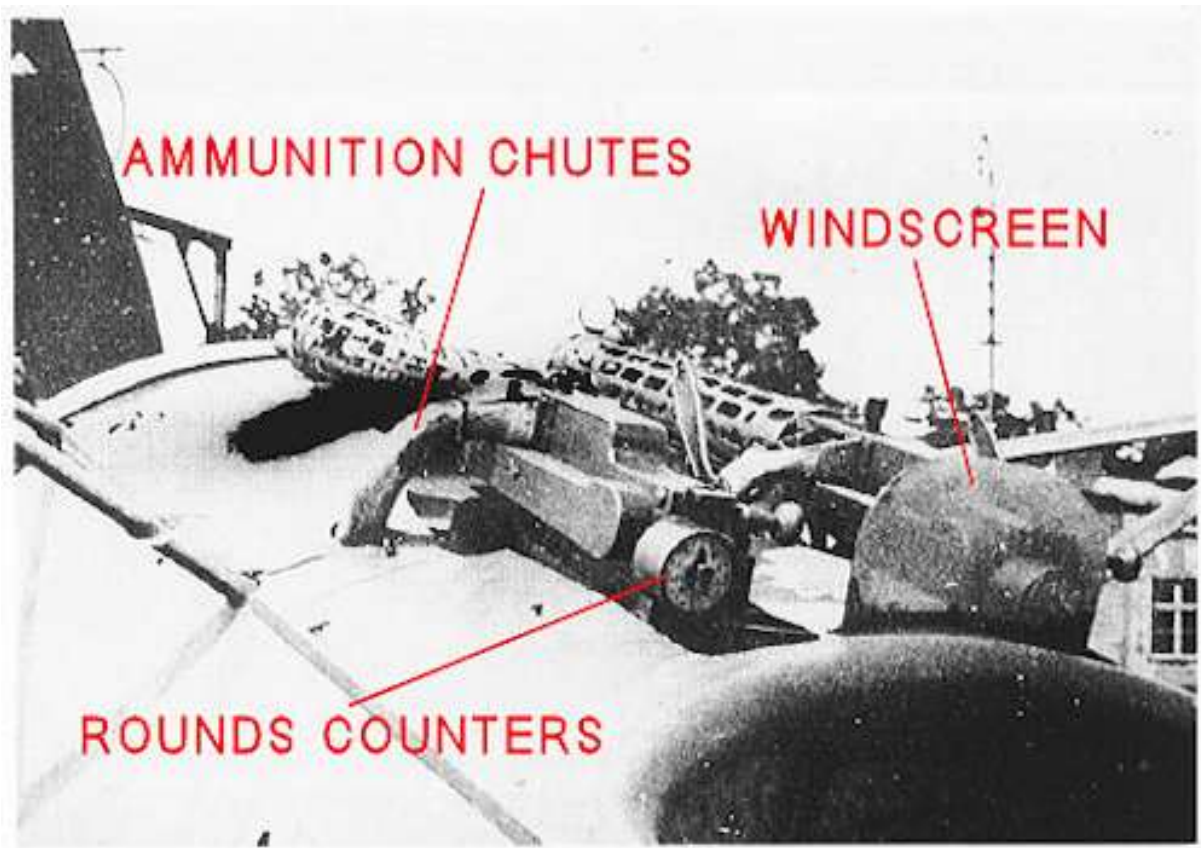

NOTE: Before continuing, the two guns should be test fitted to the cockpit decking, ensuring they both fit and align correctly and that the breech support bars, gun synchronisation cables and rounds counters on the gun breeches align and do not obstruct the fit. The ammunition feed and ejection chutes should be dry located to ensure they also align correctly.

Once happy with the fit, the rounds counters and ammunition feed and ejection chutes were fixed in position on the guns using thin CA adhesive. **NOTE:** The left gun ejection chute is not attached to the left machine gun, as it will not locate into the decking hole if attached to the gun. It must be located and secured to the gun after the gun is finally fitted.

Painting:

Each weapon was then given a coat of Tamiya Fine grey aerosol primer and when dry, airbrushed with Alclad Gun Metal lacquer (ALC-120). Once dry I dry brushed Mr. Metal Stainless Steel (213). I finally burnished the guns with the Gun Metal colour from the Tamiya Weathering Master (Set C).

The gun synchronisation cables were painted black, the free end of the wire being bent under the ammunition tank to face the engine, once the guns are finally fitted.

The two rear breech supports were paint with the same colour mix used for the cockpit side frames etc - a mix of Tamiya Dark Green (XF70) and Cockpit Green (XF71).

The rounds counters and chutes were primed then painted with Mr. Metal Colour Stainless Steel (MC213). The ammunition feed belts were painted with Tamiya Dark Yellow (XF60) and the ammunition rounds with a mix of Mr. Metal Colour Brass (MC219) and Copper (MC215).

The decals applied to each of the ammunition rounds counters on the machine guns were from the Airscale Instrument Dial Decals - Generic WW1 (AS32 WW1).

The following shots shows the two machine guns after being finally fitted to the fuselage top decking, which is yet to be weathered.



PART 7 - PROPELLER

References:

1. www.woodenpropeller.com
2. Windsock Data File 25 - Fokker D.VII by P. M. Grosz.

The actual aircraft was fitted with a two blade propeller, manufactured by 'Axial'. The kit supplied propeller can either hand or airbrushed, to achieve the desired laminated wood look for a propeller. To achieve this look effectively can be difficult and a bad propeller can ruin the look of an otherwise good model.

Some WW1 propellers have very obvious laminations of different colour and varnished woods, but many had woods and varnishes that make it very difficult to distinguish the separate laminations. This is the case for many Axial manufactured propellers, which can be seen from the photograph of an actual Axial propeller (as was fitted to a Fokker D.VII). Additionally it seems Axial propellers did not always carry the manufacturers logo, a fact stated on the 'wooden propeller' web site. Backing this up is the fact that of all the photographs shown in Windsock Data File 25 - Fokker D.VII by P. M. Grosz, only one shown logo's on an Axial propeller. Therefore I chose not to apply the decals.



The previously prepared propeller was primed using Tamiya Fine Grey (aerosol) primer and once dry, was given an airbrushed base coat of Tamiya NATO Brown (XF68). Once this coat was fully dry, a 'sponged' coat of Burnt Sienna from the 'Decoart Crafters Acrylic (water based oil paint) range was applied along each propeller blade. While still wet, a dry piece of sponge was gently dragged along the propeller blades, to slightly separate the oil paint and to show through the base colour. This creates the faint impression of similarly coloured wood laminations. Once the oil paint was dry, an airbrushed sealing coat of Tamiya Semi Gloss Clear (X35) 65%, which was mixed with Clear Orange (X26) 15% and thinned with Tamiya thinners (X20A) 20%. This sealing coat gives a varnish tint to the propeller blades. Finally the 'Mud' colour from the Tamiya Weathering Master (Set A) was applied for weathering and the propeller bosses were brush painted with Mr. Metal Colour Stainless Steel (213) and once dry, buffed with a cotton bud.



PART 8 - DECALS

The decals supplied in this kit are not applicable to the colour scheme I have planned for this build. Consequently I have chosen to use the Aviaticc (ATT32115) 1:32 scale Fokker D.V/D.VIII 4 colour lozenge decals and the Pheon Fokker E.V Volume 2 (32062) for the markings.

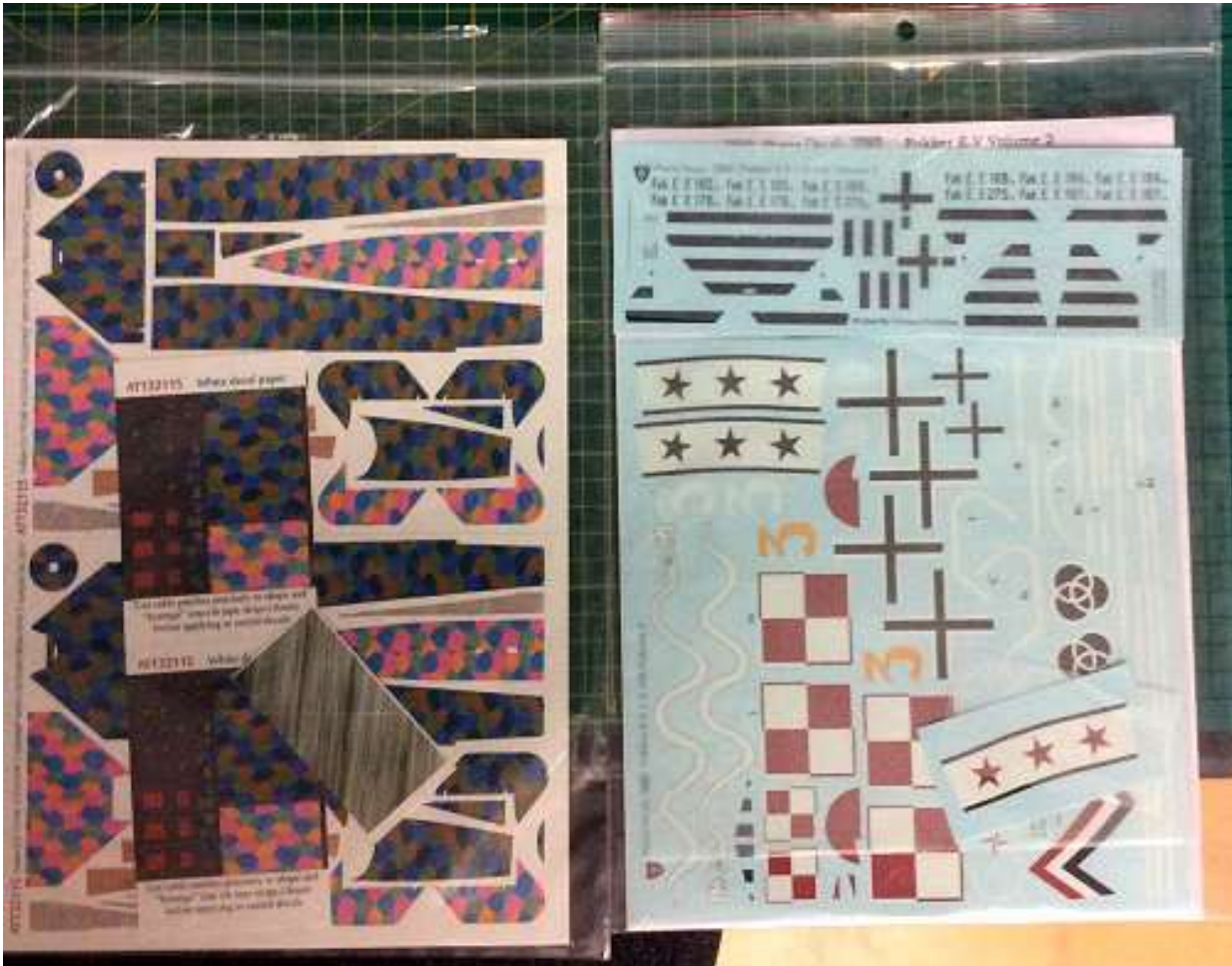

Aviaticc decals:

The 'Aviaticc' decals are different in both production techniques and application to those of the more traditional decal manufacturers.

Traditional decals are normally created using processes such as silk screen printing and are pre-shaped for the particular model markings. When placed in warm water they will detach from the backing sheet and can then be slid onto the model surface, correctly positioned then wiped with a semi-dry brush or cotton bud etc, to expel any water from under the decal. Once fully dry, decal softeners, such as MicroSol or MicroSet can be applied, if necessary, to 'weld' the decal to the model surface. Finally a sealing coat of acrylic or lacquer gloss, semi-matt or flat is applied over the decal, to seal and protect the seal and protect the decal.

However, 'Aviaticc' decals are laser printed onto a very fine carrier film and although this film is thin, the decals are remarkably resilient and somewhat 'stretchy' when being applied. This allows them to be more easily moved and positioned before being finally applied. Also with most other decals, I've used softeners to help the decals conform to surface irregularities and contours, which is something I've found is not really required for 'Aviaticc' decals, due to the nature of the carrier film. In addition, the decals need to be cut out from the sheet, so care is required to cut the decals accurately to avoid leaving gaps, especially at the edges, where the white base colour will show. That said, minor gaps may be able to be covered with weathering. For more information, refer to the instruction sheet supplied with the decals.

'Aviatic' decals are laser printed onto either 'clear' or 'white' backing, the 'clear' being dependent on the base coat you apply and the finished effect you desire. The decals are supplied with very clear instructions on their application, including when to add pre-shading to the base coat, where desired, before you apply the decals.

For this model I chose to use the 'clear' decals, in order to show the linen effect more clearly.

Firstly, and after laying down a base coat of Tamiya white (XF2), the external and internal surfaces to have decals applied was airbrushed with Alclad Clear Coat Gloss (ALC-310) lacquer, to form a gloss surface to reduce the likelihood of 'silvering' under the applied decals. This is caused by air being trapped in the rough surface of the paint, which after the decal is applied and dries, causes the 'silvering'. The decals were then applied following the supplied 'Aviatic' instruction sheet.

As an alternative, to aid in decal adhesion, you can use very diluted PVA adhesive in the decal water and on the surface of the model. Another method is to apply 'Future' to the model surface. Always ensure all solutions under the decals are removed using tissue, cotton buds etc.

Once these decals have been applied and sealed with (I use Alclad Clear Coat Gloss (ALC-310) lacquer), any other decal markings, such as the 'Pheon' external markings for this model, can be applied and sealed in the normal fashion.

Weathering:

Weathering was achieved by using Flory Clay washes and AK Interactive washes.

Flory Model clay washes come in various shades and consist of a very fine clay pigment. They are brushed over the surface to be weathered and dry in around 30 minutes. When dry, use either a piece of good, absorbent kitchen roll or a brush used for oil paint (as the bristles are harder than normal painting brushes) to remove as much of the clay wash as you need to achieve the desired effect. The damp re-activates the clay wash and allows it to be removed or worked as required.

To apply the clay wash is just a matter of brushing all over the surface to be weathered. It doesn't matter really how much is applied and it can be left on for any period, as it is easily removed without any effect on the surface underneath. The wash I used was a mix of Flory Clay Wash 'Grime' and 'Dark Dirt'.

Whatever you use to remove the clay wash, make sure it is only very slightly damp. I dab the brush or absorbent paper onto my tongue, but even then I dab it onto a dry piece of the paper. That's how 'damp' it needs to be. Any wetter and you'll find that you are removing too much of the clay wash. If that happens you would have to re-apply the wash and start again.

That said, if you not happy with the final effect, you can easily remove the clay wash by brushing with a wet brush or even airbrush water over the surface. Then you can dry the surface and re-apply the clay wash and try again until you are satisfied.

The technique is to brush over the surface to re-activate the clay wash and at the same time, to smear it over areas that had no clay wash. It'll dry more or less straight away.

Then I'll very lightly brush and/or use a piece of damp absorbent paper to remove as much as I want until I get the desired effect. If I remove too much I just reapply clay wash to that area and repeat the removal procedure.

Once finished, just run the brush under a tap to rinse out any residual clay pigments.

If you've not used Flory Clay Washes before, the best thing to do is to experiment first on a test piece. You'll soon get the hang of it.

PART 9 - RIGGING (General)

The kit instructions do not have a rigging illustration. This aircraft had, by design, very little external rigging or control lines, when compared to its contemporaries. Externally the only visible rigging was:

1. Control cables - Fuselage to elevator control horns (upper and lower).
2. Control cables - Fuselage to rudder control horns (both sides).
3. Control cables - Twin cables from the aileron bell-crank in the cockpit and through fuselage sides to wing.
4. Control cables - Wing to aileron control horns (top and underside of wing).
5. Control cables - Twin cables from control column base (under fuselage) and rearwards back into fuselage.
6. Bracing wires - Cross-bracing wires from forward lower fuselage to undercarriage axle fairing.

For this model, the internal rigging consists of the cross-bracing wires between the cockpit side frames, where visible and the flying controls for the rudder, ailerons and elevator.

The only 'exposed cable turnbuckles' were fitted close to the rudder and elevator control horns and for the undercarriage cross-bracing. The external control cables which had no visible turnbuckles (cable tie-backs only) were the twin aileron control cables, where they ran from the fuselage sides and up into the wing underside and from the control horns to the wing. Also the twin elevator control cables under the fuselage.

Before being fitted, the control horns for the rudder and elevator were drilled through at each end with a 0.3mm drill, inline with the fuselage, to accept the 'One End' turnbuckles from 'Gaspatch Models'. Also the aileron control horns were drilled, but across the ends, to be able to accept the control cables when fitted. Also, holes of 0.4mm diameter were drilled into the undercarriage fairing and bottom of the fuselage, to accept the undercarriage cross-bracing 'anchors' (GasPatch Elite Accessories).

Some modellers use micro drills manufactured for drilling printed circuit boards etc and these drill bits sometimes have identifying coloured collars fitted to the drill shanks. I have found that these drills are very sharp and instead of easing their way into the plastic of the model, they tend to bite in and effectively 'cork screw' their way in, which can cause jamming and lots of broken drills. This is not only expensive but can leave broken drill bits in the model, which are virtually impossible to extract. Take great care if using these types of drill, rather than standard High Speed Steel (HSS) drill bits, which are cheaper, but have less 'bite' when in use. Some modellers drill through the wings etc of the model and rig the model by pulling through the rigging line/thread, gluing in position and then rubbing down the exposed rigging 'tag' and re-painting that area. I prefer to drill only part way into the plastic and attach the applicable rigging fixture or line with thin CA adhesive.

For structural strength I used 'Steelon' mono-filament (fishing line) of 0.12 mm diameter. This is effectively transparent but does give a look of steel, without the need of painting or colouring with a gel pen. Typically for many German aircraft of the period, the Fokker E.V had only cables for the aerodynamic rigging and the controls.

Cable tie-backs:

To represent the tie-backs of the cables, I used 0.4 mm Nickel silver tube (Albion Alloys). This was cut to appropriate lengths by rolling a sharp scalpel blade across the tube whilst applying only light pressure. This will easily cut the tube without leaving burrs or blocking the cut end of the tube, which would stop the rigging from passing through. A length of line was passed through a tube,

Turnbuckles:

Where rigging then needs to be attached to turnbuckles, the free line from the control horn was passed through a tube, then through the hole in the end of the turnbuckle and back through the tube. The line was tightened to move the tube close to the turnbuckle, then secured using thin CA adhesive (where the free end exits the tube). The free end of the line (that not required) was cut away using a shielded razor blade. The turnbuckles used were the Type C turnbuckles from 'Gaspach Elite Accessories'

Rigging anchors:

The procedures for creating structural rigging, such as that required for the undercarriage cross-bracing cables, is the same as that described for cable tie-backs and for turnbuckles. The end result would be anchor and tie-back - turnbuckle with tie-back - other end of turnbuckle with tie-back - other end anchor with tie-back.

NOTE: When assembling this type of rigging, you need to end up with the rigging line at both 'anchor' ends tightened and secured, but with both turnbuckle connections loose. Both turnbuckle ends can now be gently pulled through the turnbuckle and associated tube to tighten the line and with the turnbuckle in the correct position along the rigging. These connections can then be secured using thin CA adhesive.

Once completed, any 'slack' in rigging can be rectified by using a small, heated soldering iron or similar. By moving the heat source close to and along the length of the line, the heat will cause the line to tighten. Obviously, care needs to be exercised as getting too close or touching the line or model surface will result in melt marks on the model or melted and separated rigging line!!

The 'anchors' and turnbuckles were 'toned down' by applying a light coat of AK Interactive wash (Leaks and Stains), then dry brushed with Mr. Metal Colour Stainless Steel (213). The rigging was sealed with a light airbrushing of Alclad Light Sheen (ALC-311) lacquer, which also gives a shine to the mono-filament and gives it a look of steel.

As you work your way through the rigging it is always good to check the rigging attachment points for any damaged paint. This can be rectified before continuing with the rigging, just in case access will be limited once all of the rigging is completed.

PART 10 - CONSTRUCTION

The basic sequence of construction is as follows, which does not follow the kit instructions

PART 1 - THE MODEL (GENERAL) -Modifications or Corrections:

PART 2 - THE COCKPIT

PART 3 - FUSELAGE INTERNALS

PART 4 - ENGINE

PART 5 - WHEELS

PART 6 - WEAPONS

PART 7 - PROPELLER

PART 10 - CONSTRUCTION (with PART 8 DECALS & PART 9 RIGGING)

PART 11 - FIGURES

PART 12 - DISPLAY BASE

CONSTRUCTION

1. **Do PART 1 first**, so that you can carry out any required modifications or corrections you want to incorporate into the model (**NOTE** - The modification to the fit of the tailplane can't be carried out until the fuselage is closed up).
2. Do Part 2 and 3, in preparation to closing up the fuselage.
3. Do Parts 4 through 7 in preparation for later in the build.
4. Fit the port (left) fuselage side to the fuselage floor and engine bulkhead. The three parts should align themselves correctly.
5. Fit the left cockpit frame to the fuselage internal surface.
6. Fit the seat assembly and the cockpit assembly. Ensure the control column passes through the forward aperture in the fuselage floor so that the bottom elevator control cables are outside. You can use Blue-Tack to temporarily hold the seat assembly in position whilst aligning the parts correctly.
7. Carefully pass the rudder and elevator control cables through the holes in the bottom of the seat frame. The two external elevator control cables pass up through the rear most aperture in the fuselage floor. The twin aileron cables (the right side cables) will pass through the pre-drilled aperture in the left fuselage side. Secure the rudder and elevator cables to the floor of the fuselage, behind the seat assembly, using thin CA adhesive.

8. Add the support bar for the ammunition containers then fix the containers to the bar using either thin CA adhesive or PVA adhesive (white wood glue) (see Part 1 - Modifications or corrections - Cockpit detail - ammunition containers [tanks]).
9. Add the machine gun support cross bar using either thin CA adhesive or PVA adhesive (white wood glue) (see Part 1 - Modifications or corrections - Cockpit detail - Gun support bar).
10. Attach two lengths of thin lead wire to the control column for the gun firing control cables. Secure using thin CA adhesive.
11. *Carefully coil the two twin aileron control cables under the ammunition containers into the forward fuselage area. Also carefully bend the two lead wires so that will not interfere with attaching the starboard (right) fuselage side.*
12. Align the starboard fuselage side to the port fuselage/floor/engine bulkhead assembly and once happy with the fit and alignment, secure in position.
NOTE: Now is the time to protect the exposed elevator controls at the bottom of the control column (see PART 1 - page 50 - WARNING).
13. Fit the cockpit forward, top decking, ensuring it aligns correctly with the fuselage sides and the engine bulkhead and that it does not foul on the cockpit frames or the added cross bars.
14. Add the tailplane, fin and elevator to the rear of the fuselage (see Part 1 - Modifications or corrections - Tailplane).
15. At this stage you should check for any gaps or imperfections and rectify using adhesive, fillers etc. It's a good idea to mask off all openings and apply primer to the model, as when dry, this will show up anything that requires attention.
16. Once you're happy to continue, mask off all openings and apply primers to the model. It should be noted that the chosen 'Aviatic' lozenge decals require a white base, but those areas that will be painted will require a grey base. To this end I used Tamiya Fine White and Fine Grey aerosol primers as follows:

White primer :

Rudder, undercarriage fairing, inboard face of wheels and fuselage assembly.

Grey primer:

Cockpit forward decking, fin, tailplane, elevator, fuselage bottom engine access panel area, engine cowl, tailplane support struts and outboard faces of wheels.

17. Once the primer base colour are fully dry, I airbrushed the cockpit forward decking and bottom engine access panel areas with a mix of approximately 35% Tamiya Dark Green (XF70), 50% Cockpit Green (XF71) and 15% Yellow Green (XF4).
18. The 'Pheon' supplied decals for this particular colour scheme have two colours for the fuselage marking No.3, white or a 'yellow'. I chose the optional white coloured number '3' marking for this model, as the 'yellow' version colour is also applied to the engine cowl, all of the supporting struts, tailplane, elevator, most of the fin and the wheel outer faces. To mix the paint to exactly match the 'Pheon' 'yellow' No.3 is very difficult. Instead for the 'yellow' colour, I mixed Tamiya Flat Yellow (XF3) 60%, Dark Yellow (XF60) 30% and Flat White (XF2) 10%, which was airbrushed onto the required surfaces.
19. When the paints have dried fully, it should look as shown in the following shot.

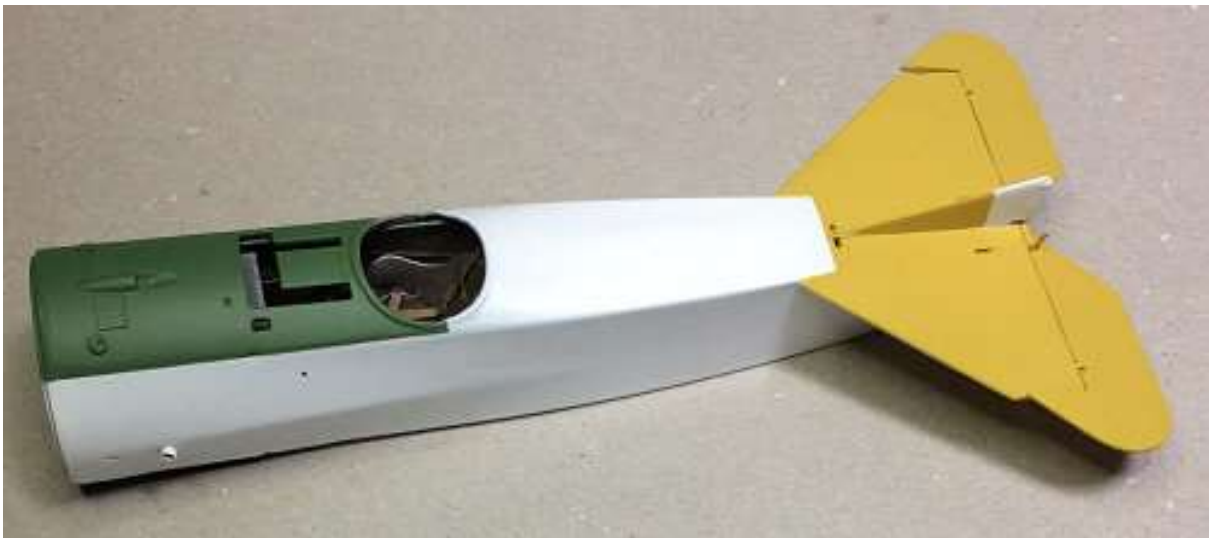

20. In preparation for applying the 'Aviatic' lozenge decals and to give a slight pre-shading to the fuselage tubular framework structure and the undercarriage fairing, I airbrushed thinned Tamiya Smoke (X19) and when dry, airbrushed a sealing coat of Alclad Gloss (ALC-310). This was also airbrushed over the rudder, elevator and the inboard wheel surfaces in preparation for applying decals to those areas.

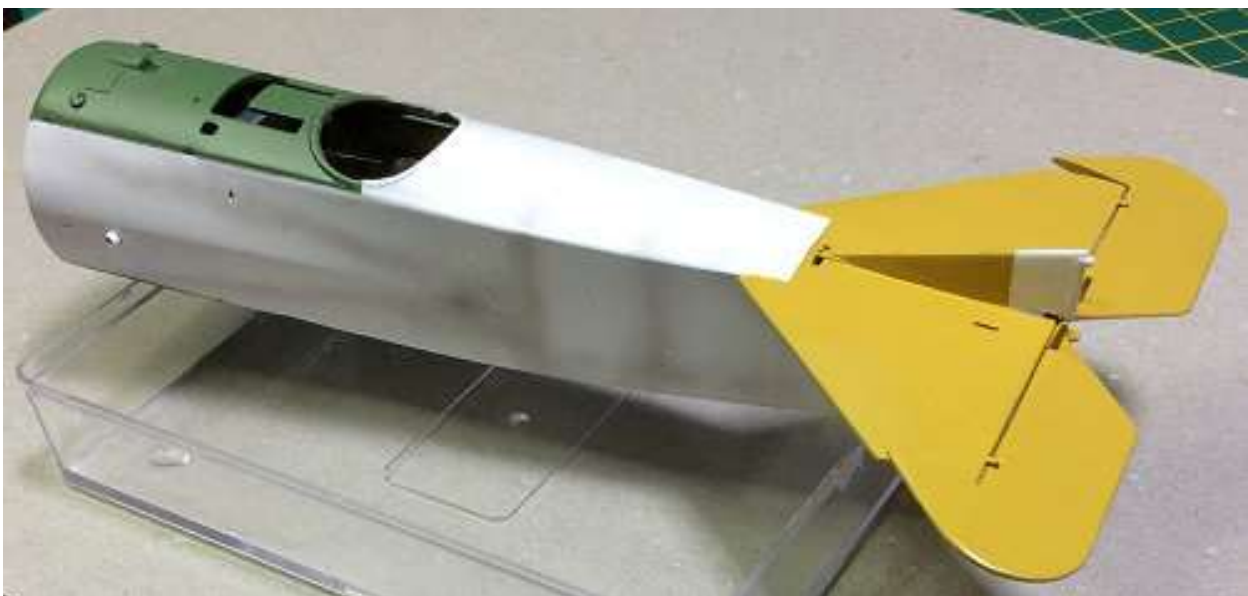

21. The next step was to temporarily fit the wing strut assemblies (created in Part 1 of this build log) and single struts between the wing and fuselage, to ensure the wing and struts are correctly positioned and aligned to the fuselage.

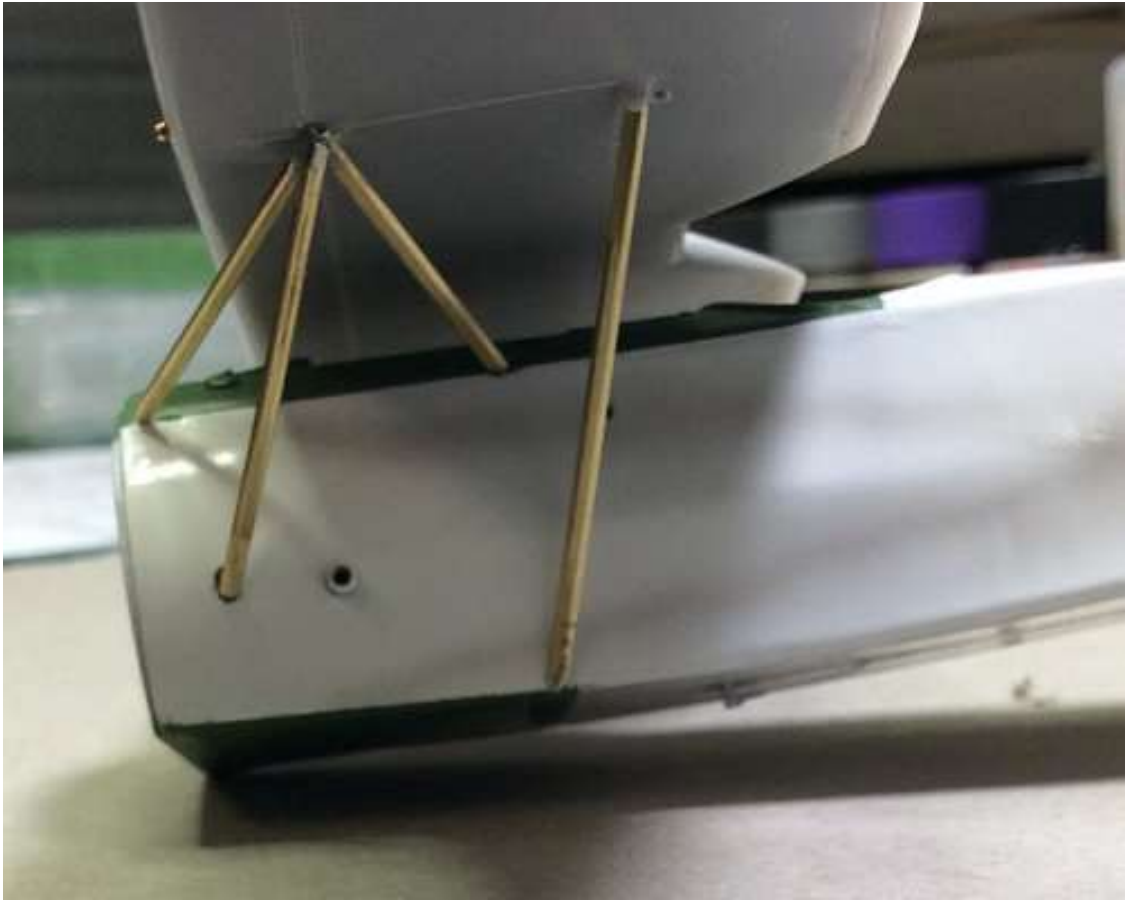

22. The next step was to temporarily fit the created undercarriage struts, to ensure that the undercarriage was correctly aligned to the fuselage.



23 The next stage is application of the 'Aviattic' lozenge decals to the fuselage, inboard faces of the wheels and the undercarriage fairing.

NOTE: These 'Aviattic' decals sheets do not have lozenge decals for the top and under side of the undercarriage fairing. However there are two similar sheets of decals supplied, so if required, the fairing can be covered with lozenge decals by cutting a suitably sized 'spare' decal.

1. This set of 'Aviattic' decals are laser printed onto a carrier film which is transparent and applied over a gloss white base in order to show the linen effect of the decals when applied.

2. The carrier film of the decals is surprisingly strong and flexible, which enables them to be repositioned easily during application.

3. Unlike traditional decals, these will need to be accurately cut out before being applied. This may seem a daunting task, but these decals can easily be cut out using a sharp scalpel blade.

4. Although in the decal instruction sheet it states the decals should be soaked in warm water for around 45 seconds, I have found no more than 30 seconds was better, so as not to chance dissolving the carrier adhesive.

5. The model surface should be gloss white and even airbrushed with clear gloss acrylic or lacquer sealer (if you feel its required), before you apply the decals.

6. The surfaces should also be free from dust etc and wetted with warm water.

7. The decals can then be applied and the water under and on the decals rolled off with dry soft brush or cotton buds.

8. Although not really a requirement, I applied Micro-Sol over the decals to ensure they conformed to the surfaces. These decals, unlike most of the more traditional decals, do not 'wrinkle' during drying of the Micro-Sol.

9. If the decals need to be placed over a protrusion, they can be cut or even drilled on the sheet before being wetted for application.

10. Once applied they should be left to fully dry, preferably overnight.

11. Where other decals are to be applied onto the 'Aviattic' decals, these areas of the 'Aviattic' decals should be airbrushed with clear gloss acrylic or a lacquer sealer, which should be allowed to fully dry before applying other decals onto them.

12. When all of the decals have been applied and are fully dry, all the decals should be finally air brushed with clear gloss acrylic or lacquer sealer, such as Alclad Gloss (ALC310) lacquer, in order to seal the decals and also in preparation for applying more decals on top or any other surface finishes you may want, such as weathering.

The shots on the following page show the 'Aviattic' lozenge decals immediately after they were applied and Micro-Sol applied. Any exposed white base colour will be painted over, such as that area around the cockpit, which is the cockpit padding and the apertures in the fuselage underside, which are for the exposed elevator flying controls. Although in the following shots the applied pre-shading is not that evident beneath the lozenge decals, it can be seen in 'real life'. Also further surface effects, such as weathering and staining are yet to be applied.



24. Having applied and sealed the 'Aviatic' decals, the next step is to apply the individual 'Pheon' decals. These are applied in the normal way onto the 'Aviatic' decals and treated with Micro-Sol. When the decals were fully set they were finally air brushed with Alclad Light Sheen (ALC-311) lacquer, in order to seal the decals and in preparation for any other surface finishes you may want to apply, such as weathering. **NOTE:** In the shots that follow, the engine cowl and rudder have been dry fitted only.

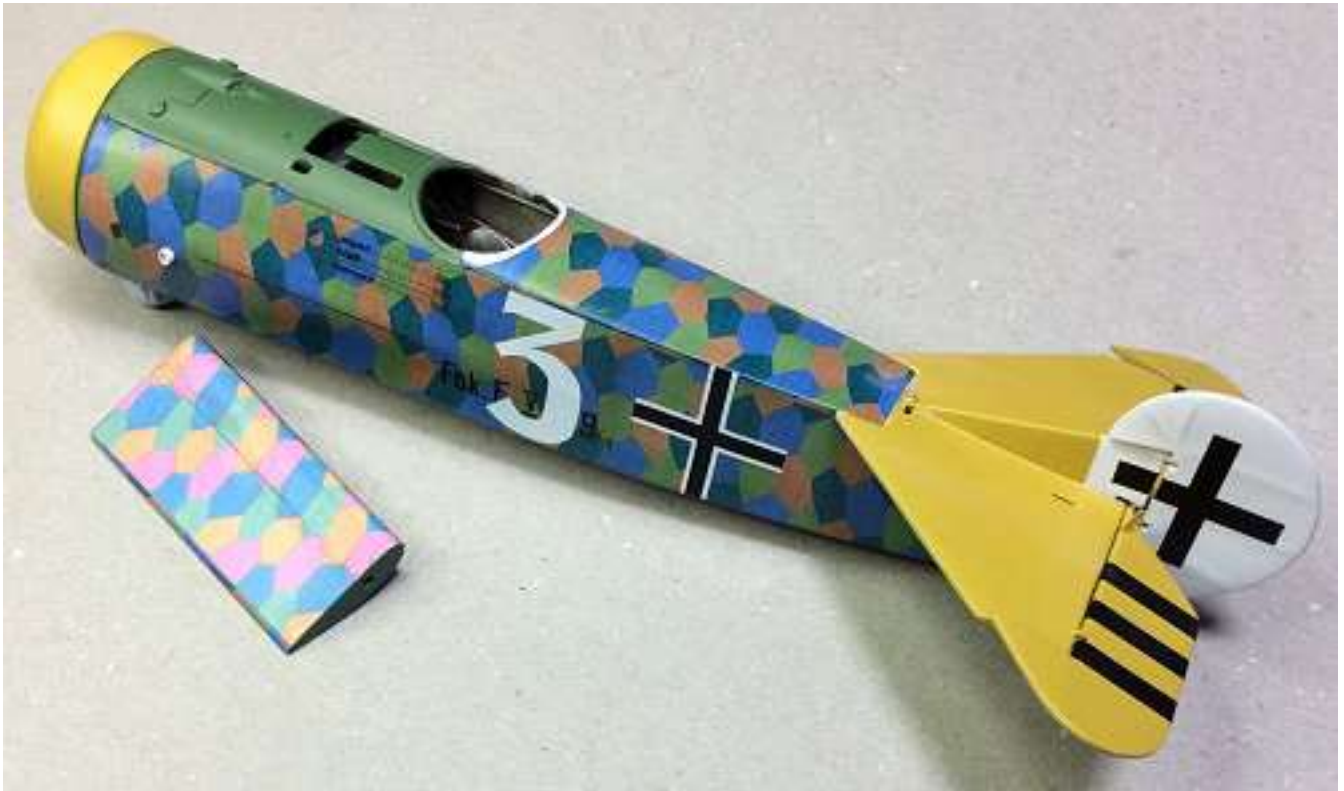

25. At this stage the two assembled and painted machine guns (Refer to Part 6 Weapons) need to be fitted on the cockpit forward decking. Take care handling the guns as they are made of resin, which is very brittle and can be snapped easily, especially small items, such as the cross-hair gun sights. Before fitting the two guns, carefully move towards the pilot seat the two thin lead wires representing the two gun firing cables located on the control column.
26. Carefully pull back into the cockpit the twin aileron control cables previously 'stowed' in the forward fuselage area.. Using thin tweezers, pass the twin cables through the holes previously drilled through the fuselage sides. Remember, the twin cables cross inside the cockpit (each pair cross over to the opposite fuselage side).
27. **NOTE:** In this step, do not fit the ammunition ejector chute for the left machine gun until after that gun has been secured in position, when you can then locate and fix the chute in its decking hole. Locate and align each machine gun into the cockpit forward decking. Ensure the lead wire, representing the synchronisation cables, are positioned between the aileron cables and the ammunition container (to avoid fouling the aileron cables). Once you have the guns positioned, secure them using either CA adhesive or PVA glue.
28. Working through the cockpit opening, position the two lead wires representing the gun synchronisation cables, down and under the ammunition containers. Use PVA adhesive or CA adhesive to secure them in position.
29. Carefully move the two thin lead wires, representing the control column gun firing cables, forward and up to the breech of each machine gun. Use PVA adhesive or CA adhesive to secure them in position.
30. If necessary, any distortion or bends in the lead wires can be 'teased' out using a tooth pick or similar.
31. Paint the two fuel/oil caps in the forward cockpit decking with Mr. Metal Colour Brass (MC219).
32. Paint the cockpit surround padding with Humbrol Acrylic Leather (62) highlighted with Tamiya Flat Brown (XF10).



33. The next step is to fit the assembled and painted engine (Refer to 4 - The Engine) into the engine bulkhead.
34. Next the engine cowl was fitted over the engine and onto the front of the fuselage.



35. The tailplane support struts and tail skid were then fitted. As the location 'dimples' for these support struts on the model are not very deep, I secured them in position using PVA adhesive (white glue), which gives the joints a degree of flexibility to prevent the struts from detaching, when the model is handled. I used the same for the tail skid.



36. At this stage it's best to run a 0.3mm diameter drill through the previously drilled holes in the flight control cable control horns on the elevator, rudder and the two rigging line anchors for the undercarriage cross bracing, previously installed in the underside of the forward fuselage. This is easier to do now, before other parts are added to the model and also ensures the rigging lines will easily pass through them later in the build.
37. Also carefully open up any previously drilled holes in the fuselage now covered by the decals or paint. These would be control line apertures and the locations for attaching the wing and undercarriage struts.
38. Next to fit are the pilot step and the two ground crew grab handles. **NOTE:** The pilot step is located on the port (left) side only. The two grab handles are located each side at the rear of the fuselage. Two holes of 0.6mm diameter and two pairs of holes of 0.5mm diameter were drilled into the fuselage for locating the pilot step and the two grab handles, which should be angled slightly outwards and be secured into position using thin CA adhesive. The following shots shows the locations for these items on the fuselage.

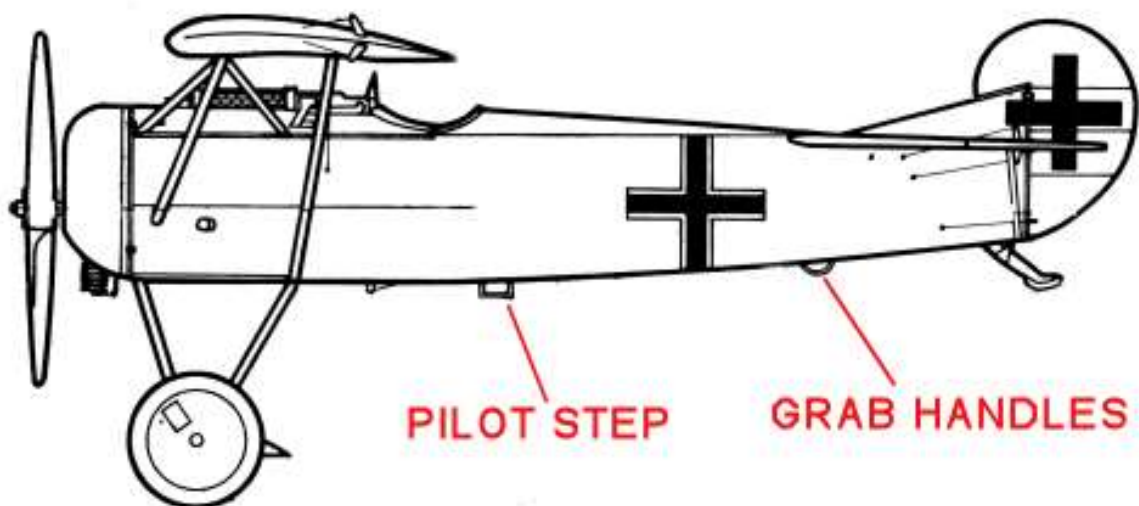

39. The actual aircraft had a rectangular access panel located outboard of the port (left hand) machine gun. Attach the previously made access panel (refer to page 35) to the fuselage decking then the attach the micro-tube 'hinge', using thin CA adhesive. The fastener for the panel is from the 'Taurus Models' resin set of wingnuts (M0025) and was also attached using thin CA adhesive.



40. The engine cowl on the actual aircraft was held in place on the forward fuselage by a cable, secured at each end at the outer edges of the engine bulkhead. This cable is not represented in the kit. To represent the cable and attachments, I secured a short length of 0.5mm diameter micro-tube at the bottom of the engine cowl to fuselage joint, using thin CA adhesive. Once cured, I threaded a length of 0.3mm diameter tinned copper wire through one of the tubes and pressed the wire around the engine cowl to pre-form the shape. The wire was then secured into the tube using thin CA adhesive. The opposite end of the wire was then threaded through the other tube, pulled to tighten around the engine cowl, and secured with thin CA adhesive. Protruding excess wire was then trimmed off.



41. Now is the best time to apply weathering to the fuselage, rudder, wheels and also the undercarriage fairing, as this will be easier to achieve at this stage, before the wing, struts and rigging are installed. The weathering is mainly applied using the 'Flory' fine clay wash Dark Dirt (for the method refer to page 59). The shot below shows the wash as applied to the fuselage.



42. Once fully dry, the wash was removed, as required, using a very slightly 'damp' brush and absorbent kitchen roll. The whole fuselage was sealed by an airbrushed coat of Alclad Light Sheen (ALC311), in preparation for more weathering mediums. **NOTE:** Make sure the exposed aileron control lines are protected from the sealing coat by a covering of 'de-tacked' masking tape or similar.
43. The lower edges of the fuselage were given a dirt 'dust' look by the application of the Tamiya Weathering Master set, namely Mud from Set A and Rust from Set B.





44. Engine leaks and stains were made using AK Interactive's aircraft engine oil (AK2019) and leaks kerosene and stains (AK2039). **NOTE:** The undercarriage fairing top surface on the aircraft was usually heavily contaminated with engine oil, which was common with rotary engines.



45. The next stage is to add the wingnut and Fokker type fasteners to the cockpit forward decking and under fuselage, forward access panels. These are from 'Taurus Models' - the sets of the Fokker Cowl Nuts (D3224) and Wingnuts (MC0025). The following shots shows typical fasteners fitted to actual aircraft and to the replica aircraft that was built by 'The Vintage Aviator Ltd'.

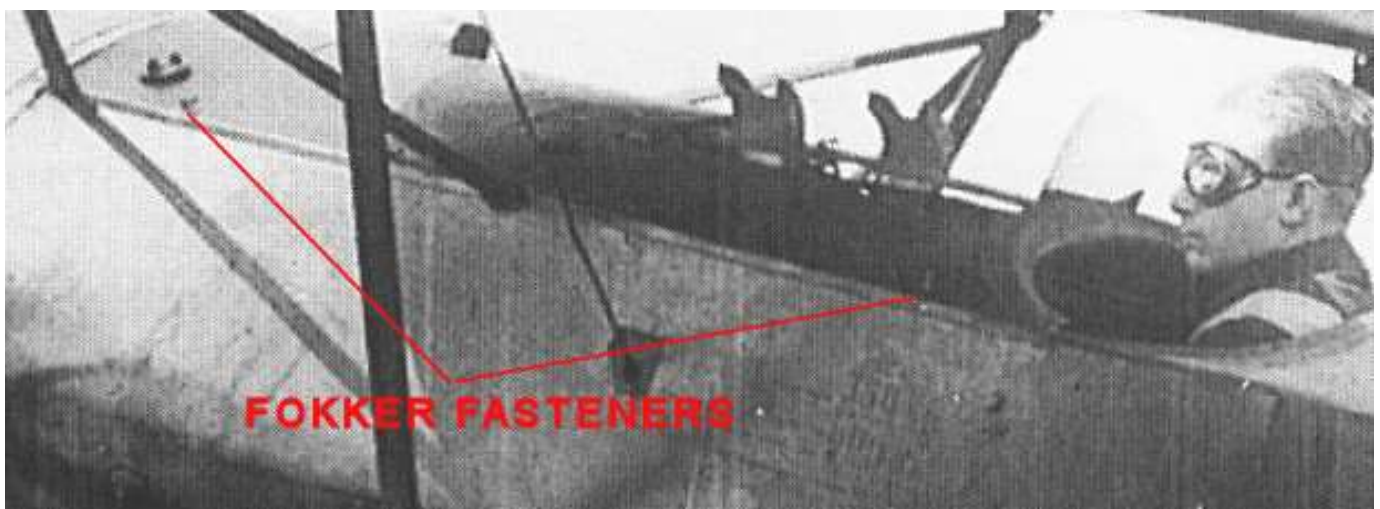
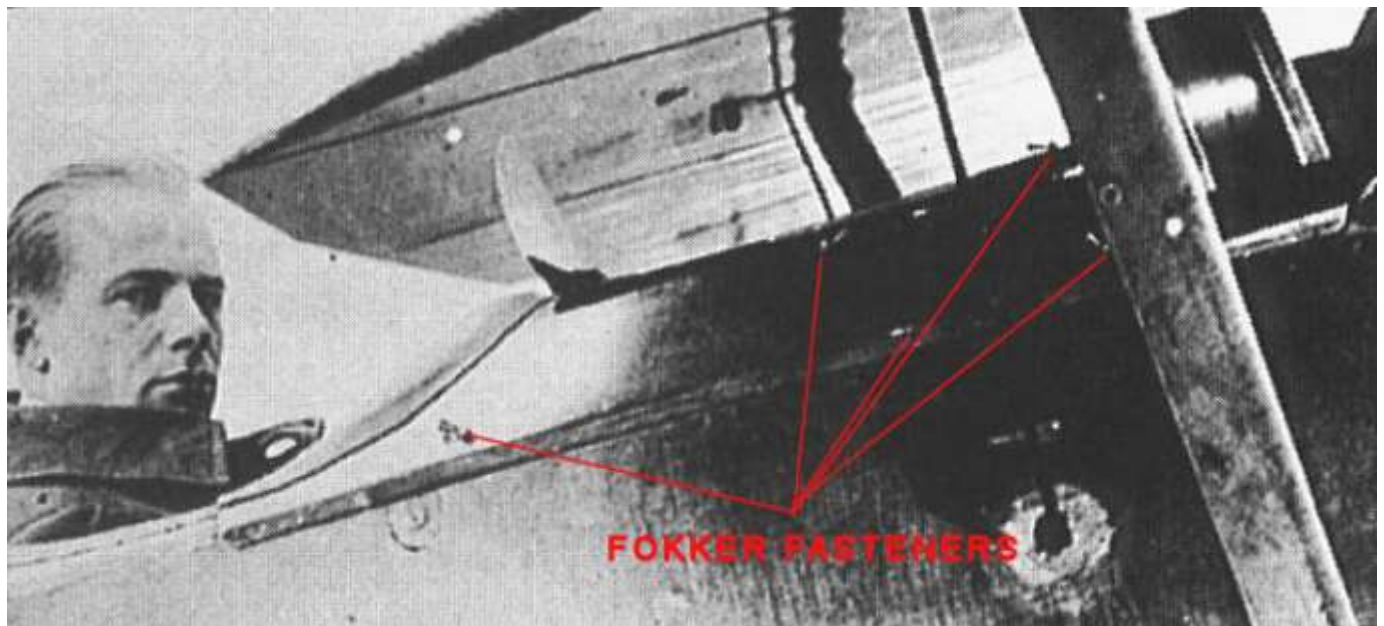

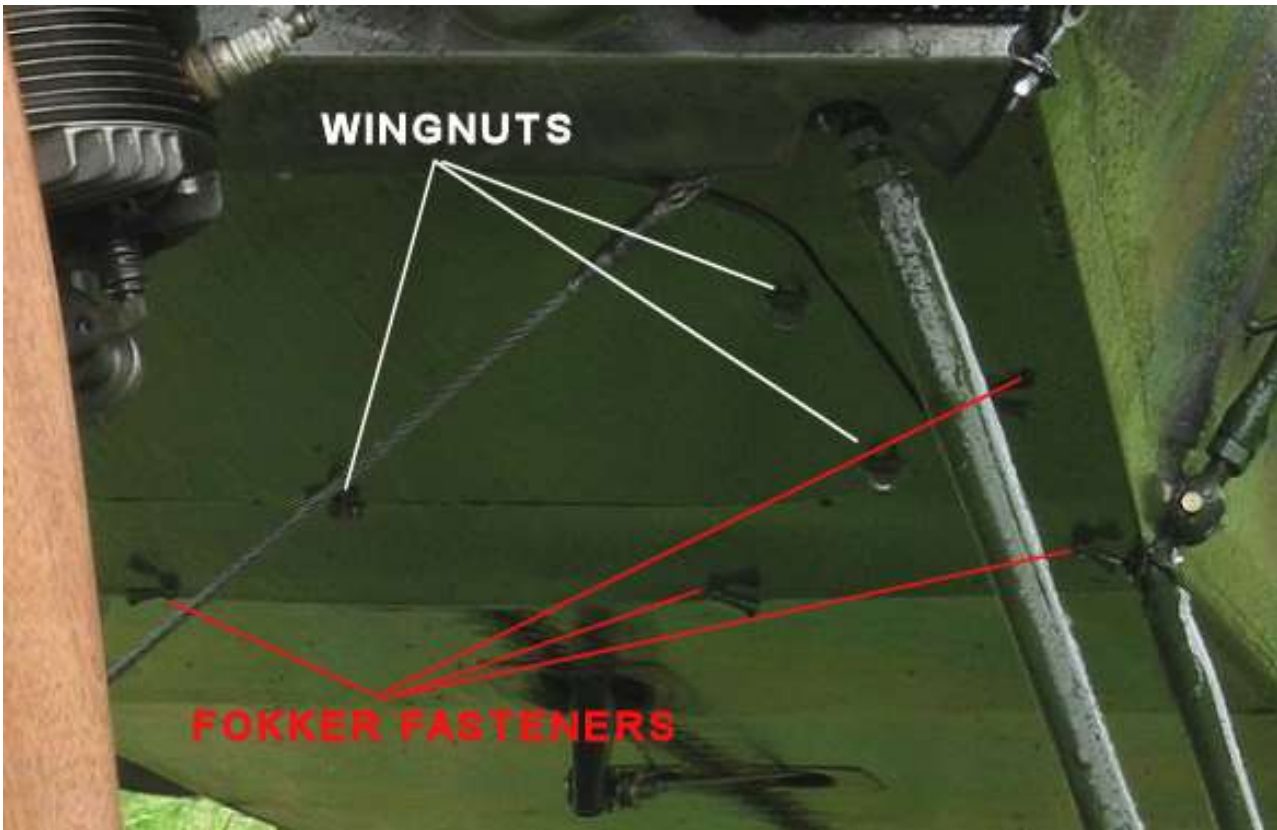
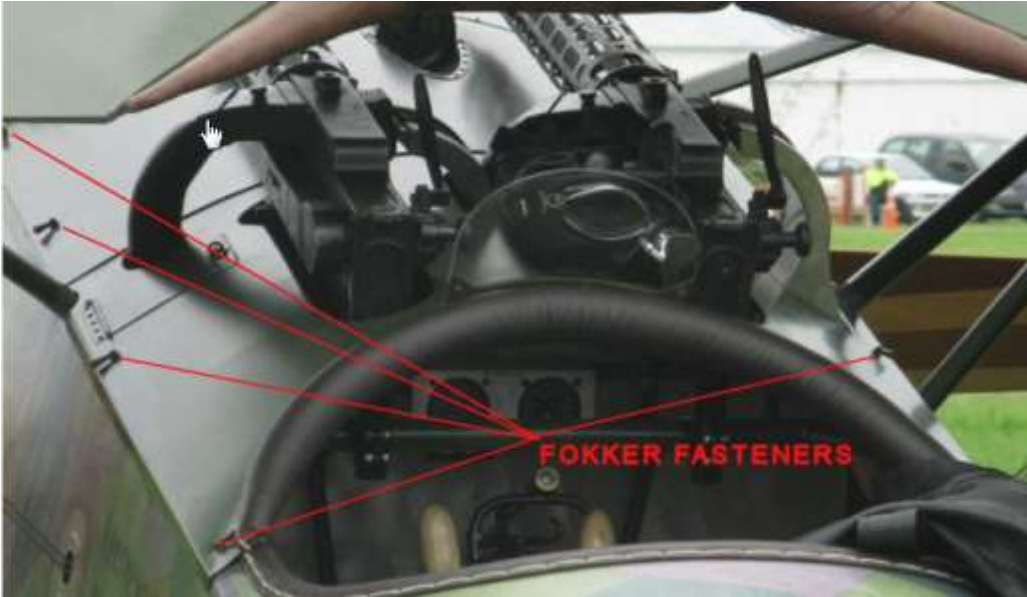
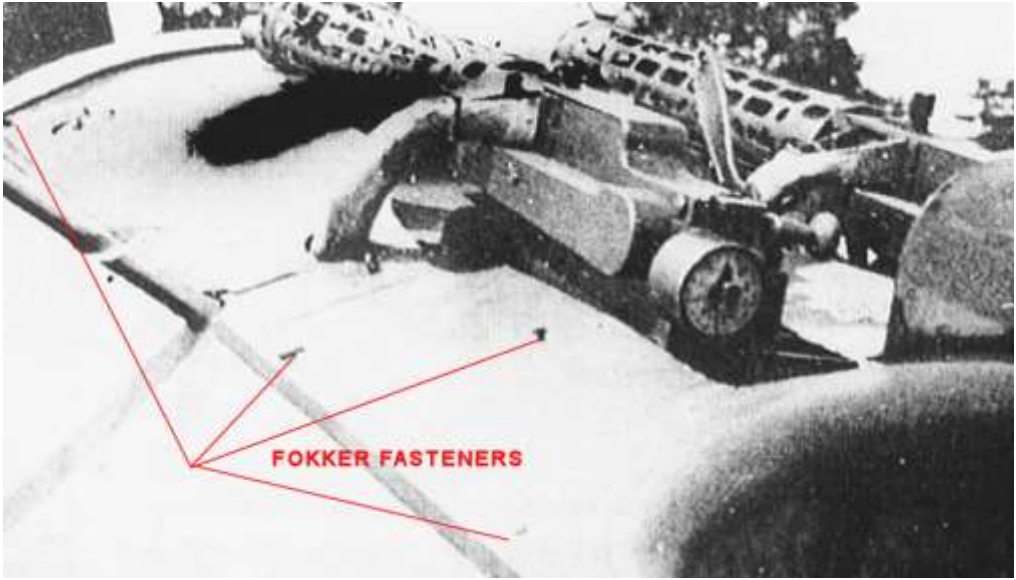

The Taurus Fokker Fastener set requires the locking head to be attached to the separate stem, which itself is to be inserted into a pre-drilled 0.5 mm diameter hole. I personally found to do this was extremely difficult, due to the extremely small size of the items and the frailty of the resin. Instead I drilled 0.7mm diameter holes at each Fokker fastener location, into which I inserted short lengths of Albion Alloy 0.7mm diameter brass tube (MBY07). These are to represent the flat washer base of the Fokker fastener. I added trailing stains behind each using the soot colour from the Tamiya Weathering Master Set B.



I then attached the fastener locking heads, which were painted with Mr Metal Colour Stainless Steel (MC213), lightly buffed, with thin CA adhesive.

Finally I attached the wingnut fasteners, which were painted with Mr Metal Colour Stainless Steel (MC213), lightly buffed, to the under fuselage access panel using thin CA adhesive.



46. Finally the pilot's windscreen needed to be fitted. The kit supplied item is a pre-outlined windscreen on thin transparent sheet, which I found not only tricky to cut out, but doubted it would adhere to the model. In addition the windscreen appears to be too large, based on photos of the aircraft, showing the windscreen installed between the breeches of the two machine guns. Therefore I used a spare windscreen from another model. This item has at the bottom a locating tab, so I drilled a row of three 0.7mm diameter holes into the pre-molded front decking mounting strip. I then 'angle' drilled the holes to form a slot and into this slot I secured the windscreen using PVA adhesive (white glue).

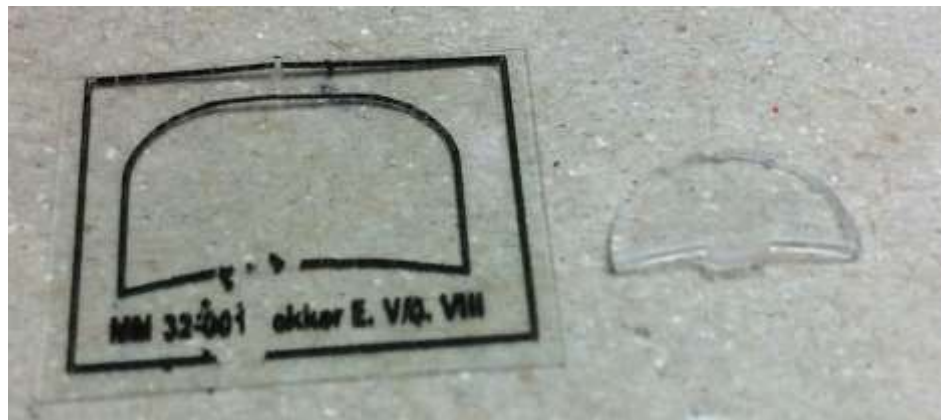

47. General information for rigging in contained in Part 10 of the build log. The next task is to pre-rig the rudder flying control cables and the undercarriage cross bracing on the bottom of the fuselage. It is easier to do before both of the rudder and the undercarriage are to be finally fitted. Also at this stage, the four elevator control cables are pre-rigged onto the four control elevator control horns.

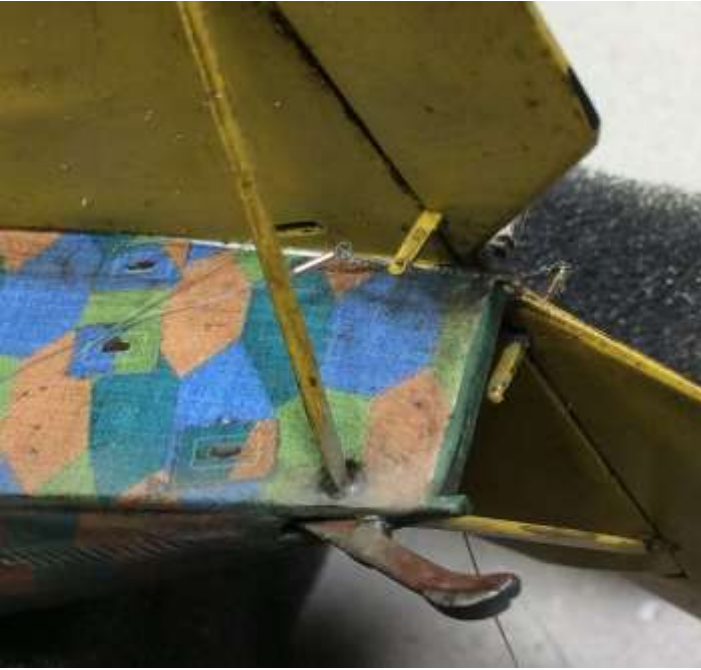

48. Once pre-rigged, the rudder was attached to the fin. Then the ends of each of the control cables for the rudder and elevator were inserted in the relevant fuselage apertures and fixed in position using thin CA adhesive. Each turnbuckle assembly was then given a light coat of AK Interactive Leaks Kerosene and Stains (AK2039), to tone them down.



49. The already made brass undercarriage support struts were located into the pre-drilled holes in the undercarriage fairing and secured in position using thin CA adhesive. The struts were then located into the four pre-drilled location holes in the forward underside and secured in position using thin CA adhesive. A short length of 0.5mm diameter brass micro-tube was threaded onto the cables, which were then passed through the pre-fixed turnbuckles and back through the tubes and tightened and secured with thin CA adhesive. Each turnbuckle assembly was then given a light coat of AK Interactive Leaks Kerosene and Stains (AK2039), to tone them down. Finally the four support struts were given a wash of 'Flory' Dark Dirt clay wash and after cleaning off as required, were given a sealing coat of Alclad Light Sheen (ALC311) lacquer.

In the shot on the following page the cross bracing wires for the undercarriage can be seen, in addition to the engine 'oil staining' that was previously applied to the top surface of the undercarriage fairing.

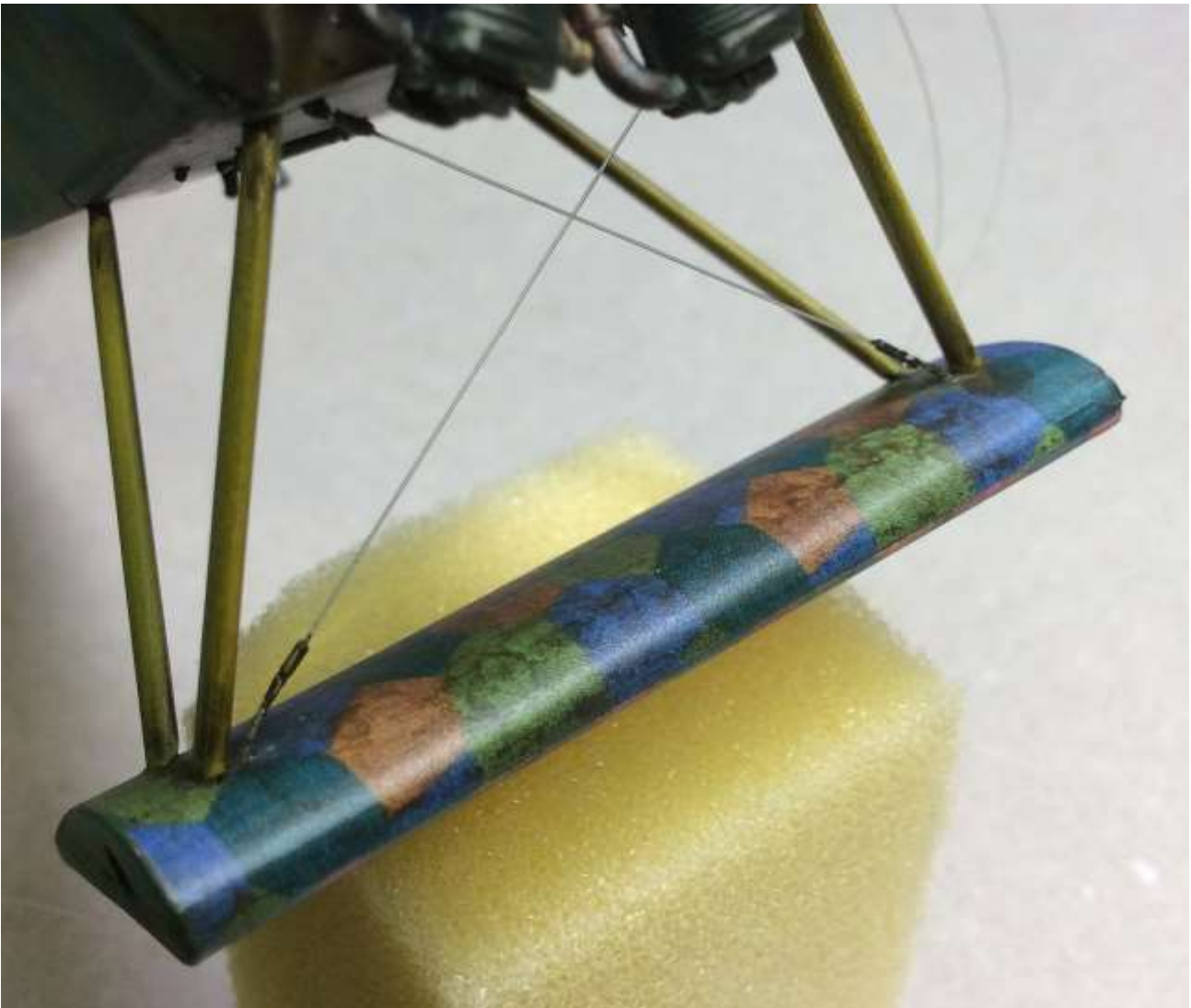

50. With the fuselage completed, apart from adding the wheels, it's now time to work on the wing. The prepared wing was first primed with Tamiya Fine Grey aerosol primer. There is much debate as to the colour schemes used for the wing of this aircraft, so I have chosen to go with the scheme that is shown on the illustrations supplied with the 'Pheon' decal set - Fokker E.V Volume 2 (32062). NOTE: The wing was covered in plywood, not linen.

Top of wing



Underside of wing

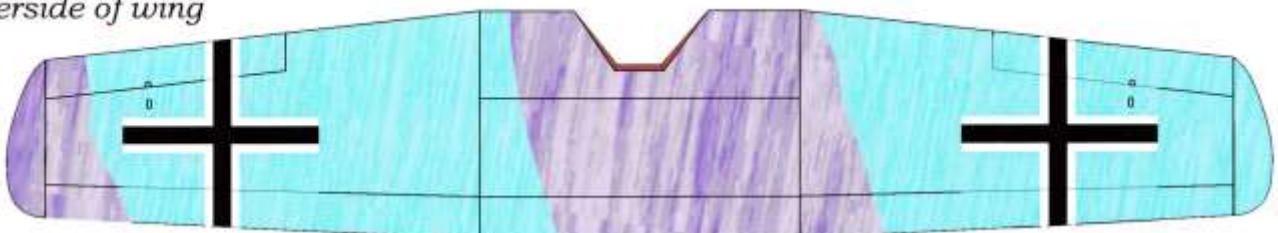

The first step after priming is to airbrush the lighter colour on the lower wing surface. Once dry, the darker colours on the wing upper surface can be airbrushed. In this way the darker colours will cover the lighter colours. Water based acrylic oil paints will be used to create the faint surface streaking, as if the paint top coats were applied by brush. As can be seen from the previous shot, the upper wing surface colours were painted at an angle across the surface. The upper wing surface was painted in green and brown angled areas. The lower surface was painted in a mirrored pattern of light violet and blue areas. Both of the upper and lower wing surfaces exhibited 'streaking' of the base coat colour through the top coat colours. This streaking was not uniform, being slightly lighter in some areas and darker in others.

Painting the underside surface:

Using the 'Pheon' illustration as a guide, I cut the colour scheme pattern edges from a Tamiya masking sheet. The whole lower wing surface was then airbrushed with a thinned mix of Tamiya Flat Blue (XF8) 25%, Flat White (XF2) 65% and Light Blue (XF23)10%. Once dry the surface was sealed with Alclad Light Sheen (ALC-311). Then the pre-cut masking was then positioned on the surface as shown on the 'Pheon' illustration and the violet colour airbrushed with a thinned mix of Tamiya Purple (X16) 10% and White (X2) 90% and when dry, the surface was sealed with Alclad Light Sheen (ALC-311). Although the applied colours are not an exact match to those shown on the 'Pheon' illustration, they still need to have the oil paint streaking, 'tone down' sealing coat and weathering applied.



Painting the upper surface:

The same process was used to apply the upper wing colours. Before painting, apply masking along the wing upper leading edge, to separate the upper and lower colour schemes. First the wing upper surface green colour was airbrushed with a thinned mix of Tamiya Dark Green (XF70) 35%, Cockpit Green (XF71) 10% and White (X2) 55%, then when dry, sealed with Alclad Light Sheen (ALC-311) lacquer. When masking the green to apply the brown colour, make sure the masking aligns with the violet colour applied to the wing lower surface. The brown colour was airbrushed with a thinned mix of Tamiya NATO Brown (XF68) 70%, Hull Red (XF9) 15% and White (X2) 15% and again, when dry, was sealed.



Streaking effect:

The actual aircraft wing was painted by hand and this gave the painted surfaces a faint streaked effect. To replicate this I used water based acrylic oil paints from the 'Decoart Crafters Acrylic' paint range. To apply streaking to the brown colour I used Burnt Umber and for the other colours, Light Antique White.

To apply the oil paint I used a 'serrated' oil brush (tooth edge), a plastic lid containing dampened kitchen tissue and a dish of water.



Underside wing streaking:

I placed a few drops of the Light Antique White onto the dampened tissue. This stops the paint from drying too quickly. Referring to the 'Pheon' illustration and working at a slight angle and in sections across the wing surfaces, I applied light strokes of the oil paint across the wing surface, whilst regularly cleaning the brush in the dish of water then dabbing it onto dry tissue paper. The brush was then used to brush and 'thin out' the applied oil paint, until the desired effect was obtained. Once dry I did the same but using the Dark Turquoise oil paint, to blend with the previous oil paint. Ensure you regularly wash the brush, to prevent a build up of oil paint and to avoid transferring it back onto the model surface. However, applying this water based oil paint over the previous sealed surfaces means it can be easily removed with a damp brush or similar, if you are not happy with the effect. Once satisfied with the effect applied and when the oil paint was fully dry (which does not take long), I sealed the surface with airbrushed Alclad Light Sheen (ALC-311). This seals the oil paint and allows final weathering to be applied.

If you are not sure about this process then practice first on a test piece.

The following shot shows the applied oil paint, which has yet to be sealed and final weathered.



Upper wing streaking:

Using the same process, I placed a few drops of the Light Antique White onto the dampened tissue and applied the oil paint to the blue and violet colours. I did the same on the brown colour, but used the Burnt Umber oil paint instead, mixed with a small amount of Humbrol 'Smoke' weathering powder (96309). The 'cut out' area in front of the pilot on the wing trailing edge was brush painted with a mix of Tamiya Flat Brown (XF10) and Humbrol Leather (62). Again, once the paints had fully dried, I sealed the surfaces with airbrushed Alclad Light Sheen (ALC-311) lacquer, to seal the paints for final weathering.



Decals:

The decals required on the wing consist of the four 'Balkenkreuz' insignia on the wing upper and lower surfaces, plus the two 'Anstellwinkle' (work angle) legend decals located on the trailing edge of the wing lower surface, adjacent to 'cut-out'. Before applying the decals, a sealing coat of Alclad Gloss (ALC-310) was airbrushed over the wing where the decals were to be located. Then after applying the decals and after they were fully dry, they were airbrushed with a final sealing coat of Alclad Semi-Matte (ALC-311) lacquer.



51. Rigging the wing ailerons:

The two wing ailerons have control cables that run from apertures in the wing onto each end of the control horns. Normally for this type of rigging I would use 0.12mm diameter mono-filament (fishing line), but given the frailty of the kits control horns, they would not be able to take any stress loading. Therefore in this instance I used micro-tube instead. I cut 4 lengths of Albion Alloys 0.2mm diameter Nickel-Silver tube (NSR02) and 4 short lengths of their 0.4mm brass tube (MBT04). A brass tube was secured to the end of each Nickel-Silver tube, then each Nickel-Silver tube was located into it's wing aperture. The brass tube at the other ends were rested against the control horns and secured in position using thin CA adhesive. To 'tone down' the tubes, I applied AK Interactive Leak Kerosene and Stains (AK2039) over the 'cables'.



Final weathering effects:

The weathering applied consisted of 'Flory' Dark Dirt clay wash and Tamiya Weathering Master effects. First the Flory wash was applied just along the wing panel lines and over the decals when dry, removed as required to highlight the panels. How to apply the 'Flory' wash is described in this build log at Part 9 - Decals. Once the desired effect was achieved and the clay wash was fully dry, I sealed the surface with airbrushed 'MRP' Semi-Matte (MRP-126) lacquer with a few drops of 'MRP' Black Night Camouflage (MRP-255) paint, to 'knock back' the brightness of the colours and also to add slight 'dirt streaking' to behind the aileron control horns/wing support strut attachment locations. Finally I sponged on the 'Rust' colour from the Tamiya Weather Master (Set B) along the wing leading edge.



52. Attaching the wing to the fuselage:

Now the wing needs to be attached to the fuselage using the brass struts created earlier in this build. Provided the struts were test fitted with any adjustments required, the wing will fit on the various strut location pins. The first step is to fit the '3' strut assemblies into the fuselage location holes using thin CA adhesive. The model was then laid upside (on the wing upper surface) on a piece of sponge, placed under the centre section only to protect both of the aileron controls. Then the two longer side struts were then inserted and again secured in position with thin CA adhesive. Once set, the struts were given a wash of 'Flory' Dark Dirt clay wash, which when dry was removed as required.



53. Attaching the aileron control cables to the wing:

Now that the wing is fitted, the aileron control cables can be attached into the apertures in the wing underside. The model was laid upside (on the wing upper surface) on a piece of sponge, placed under the centre section only (to protect both of the aileron controls). Also a piece of sponge was laid under the unprotected rudder. The twin cables exit the single holes in the fuselage and are therefore close together. However, where the cables enter the wing aperture, they need to be separated. To achieve this separation, I cut the aileron cable lines so that under tension, the ends still entered the wing apertures. These were then secured into the apertures, at each side to maintain a gap, using thin CA adhesive. Any slackness in the secured cables can be tightened out by carefully applying heat close and along the lines. Doing this causes the mono-filament to shrink. The applied heat can be derived from a small soldering iron or similar, but take extreme caution, as getting too close to the line or model parts will melt the line model part.

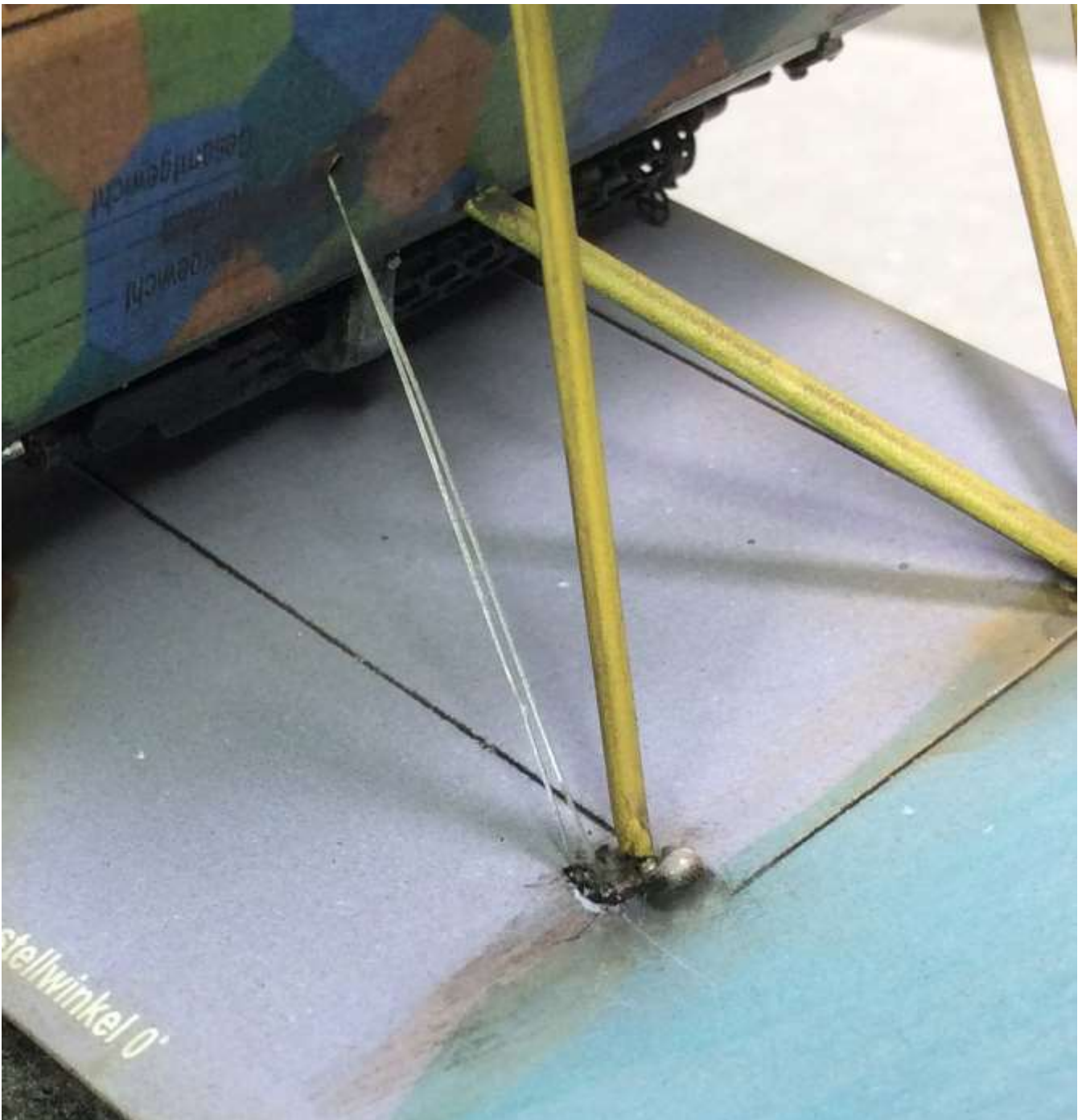

54. Attaching the wheels:

The wheels are attached to the half axles, which slide into the undercarriage fairing. I drilled a single 0.8mm diameter into the centre of each tyre on the wheels, making sure the drill was also aligned to the centre hub of the wheel. Into these holes I secured a straight length of 0.8mm diameter paper clip, using thin CA adhesive. These pins will hold the model firmly to it's display base.



55. The final step is to fit the previously completed propeller to the engine, by inserting the pin in the rear face of the propeller boss, into the hole drilled into the engine propeller shaft. The propeller was secured in position using thin CA adhesive.



The aircraft model is now complete.

PART 11 - FIGURES

References:

German Air Forces 1914-18 - Elite, Osprey Publishing by Ian and Graham Sumner

The figure I chose to use is the 'Standing German Airman - Copper States Models (F32-040). Although manufactured in 8 resin parts, the fit of the two sides of the pilots jacket left gaps, which needed to be filled with 'Vallejo Plastic Putty', then sanded.

NOTE: When brush painting with Tamiya acrylic paints, I always add a small amount of their X20A thinners or Mr. Colour Levelling Thinners, which keeps the paint 'more' fluid. Doing this allows the paint to be more easily applied by brush, especially when blending different paint colours.

Once the figure was assembled (using thin CA adhesive), the figure was given a primer coat of Alclad Grey Primer and Micro-Filler (ALC-302). The figure was then hand painted using Tamiya acrylic paints mixed with a few drops of Mr. Colour Levelling Thinners:

1. Shoes - NATO black (XF69)
2. Leather over-boots - NATO Black (XF69)
3. Uniform jacket - RLM grey (XF22) with NATO Black (XF69)
4. Trousers - Light Grey (XF66) mixed with RLM grey (XF22)
5. Hat - NATO Black (XF69), RLM Grey (XF22), Red (X7), Flat Blue (XF8), White (X2)
6. Flight jacket - NATO Black (XF69)
7. Flesh - Model Colour Skin Tone (70.815), Beige Red (70.804), Burnt Red (70.814)
8. Hair - NATO black (XF69)
9. Buttons/Buckles - Mr. Metal Colour Stainless Steel (213)
10. Pilots map case - Red Brown (XF64) with Humbrol Leather (62)

NOTE: Highlighting was carried out by either lightening or darkening the colours used (*e.g. adding small amounts of Light Grey (XF66) to the colour used for painting the flight jacket*).

The various shadows and highlights were blended into the base colours while these were still wet, which allows you to blend the paint, rather than ending up with stark contrasts.

A coat of Alclad Light Sheen (ALC-311) lacquer was airbrushed over the flight jacket, leather over boots, pilot's map case and the peak of the hat. This was done to give these areas a light sheen, consistent with leather. The face and hand were with airbrushed with Alclad Flat (ALC-314) lacquer.

The shoes were weathered using the 'Mud' colour from the Tamiya Weathering Master (Set A).

The photographs on the following page show the completed figure.



PART 12 - DISPLAY BASE

The display case is made from 6mm thick Piano Black Acrylic sheet and the transparent top is fabricated from 3mm thick Clear Acrylic sheet. This was made for me by an on-line manufacturer. The name plaque was also made by an on-line retailer and was attached to its mount.

The model and pilot figure were positioned on the base in their final positions and the pin locations were marked on the base. Three 1.0 mm holes were drilled into the base to correspond to the paper clip pins in the two wheels and the one in the leg of the pilot figure. Three lengths of paper clip were cut and temporarily located into the three holes.

The grass mat was cut to shape from a sheet of 'Model Scene Grass Mats'. The cut mat was then positioned on the base and with the three pins protruding through the mat. The outline of the grass mat was then lightly scored into the base surface. The grass mat was then removed and the black base was scuffed inside the mat outline with a medium grade glass paper in order to give a key for adhesive. The back of the grass mat was then lightly sprayed with water.

NOTE: If too much water is sprayed onto the grass mat and/or too much adhesive is applied to the base, the result will be that adhesive will show through the grass mat and possibly still be visible once the adhesive has fully dried.

A coat of PVA adhesive (wood glue) was applied the base over the scuffed area and slightly outside the outline of the grass mat (for applying a sand border) The grass mat was then laid onto the PVA adhesive and positioned correctly, again with the temporary pins protruding through. Light pressure was applied to ensure the mat was in contact with the adhesive. While the PVA adhesive was still wet, dry sharp sand was sprinkled around the edges of the grass mat and lightly pressed into the PVA adhesive. Once the PVA adhesive was dry, the excess sharp sand was 'knocked' off the base. Don't brush off the excess sharp sand or you may scratch the exposed base surface, which is acrylic sheet and easily marked.

Kitchen 'Cling-Film' was positioned around the grass mat (slightly away to leave the applied sharp sand exposed) and held in position with thin modelling masking tape, following the outline shape of the grass mat (maintain the curved edges of the outline by avoiding straight or sharp edges of the tape). This sand border was then airbrushed with Tamiya Flat Brown (XF10) and once dry was lightly dry-brushed by hand with Tamiya Dark Yellow (XF60) to add colour variation. This border effect can also be achieved by hand brushing, in which case the Cling Film and masking tape would probably not be needed.

To add variation to the grass mat, small clumps of 'Mini-Nature' two colour grass tufts (737-22S) can be secured in place with PVA adhesive. Although slightly two tone in colour, these grass tufts can be lightly dry-brushed with Tamiya Dark Yellow (XF60) to enhance the effect of dry grass.

The three temporary paper clip pins were then removed and the three holes 'cleared out' with a 1.0 mm drill to ensure the model pins would fully seat into the holes. CA thin adhesive was then applied to the two wheel pins and the model was carefully seated into the two previously drilled holes. Light pressure was applied to the wheels and rear fuselage to ensure the model 'sat' naturally on the grass mat. The same was applied for any figures. Any light weight accessories were secured in position using PVA adhesive only.

EXAMPLE OF DISPLAY BASE



COMPLETED MODEL PHOTOGRAPHS





















END