

Mikes WW1 Aircraft Models

I have always held a fascination with early military aircraft. After serving for 27 years in the Royal Air Force, I became a Military Aerospace Technical Author. Although, as most modelers, I got involved in the world of construction kits at an early age, I stopped for most of my service career and for some years afterwards.

I started modeling again a few years ago and now enjoy the challenge of building aircraft of World War One. Since posting photographs of my completed models online, several people have asked if I would create a 'build log' for future builds. I don't consider myself a 'master' of this craft, but hope to be able to pass on what I have learned. As such, this is my build log, which covers my build of the 'Aviatic' 1:32 'skeletal' scale model of a Fokker D.VII, including donor parts from the 'Wingnut Wings' Fokker D.VII (OAW built) kit.

Mike 'Sandbagger' Norris

Email: sandbaggeruk@sky.com

Web Site: <http://igavh2.xara.hosting>

Completed: June 2019

CONTENTS

INTRODUCTION
AFTER MARKET
THE MODEL (General)
THE AIRCRAFT
PART 1 - PARTS PREPARATION
PART 2 - WOOD EFFECTS (General)
PART 3 - WEATHERING (General)
PART 4 - DECALS (General)
PART 5 - RIGGING (Description)
PART 6 - ENGINE
PART 7 - PROPELLER
PART 8 - FUSELAGE (with engine, cockpit, weapons)
PART 9 - LOWER WING
PART 10 - UNDERCARRIAGE ASSEMBLY
PART 11 - UPPER WING
PART 12 - FINAL ASSEMBLY
PART 13 - FIGURES AND ACCESSORIES
PART 14 - DISPLAY
COMPLETED MODEL PHOTOGRAPHS

INTRODUCTION

Before I start with the build log, I'd like to show how I've set up my work area. I prefer to keep the work area as clear as I can (I've lost too many small items in the past). I think it's important to have the tools etc you need ready to hand and other, non-essential stuff tucked out of the way until needed. I'm lucky in that I have my 'man cave', which is sorted into a modelling area, airbrush spray booth in addition to my work station PC, games PC and games console.



AFTER MARKET

General

'Aviatic' 1:32 Fokker seat and cushion (ATTRES 022),
'Gaspatch' Spandau 08/15 extended loading handle (18-32128),
'HGW Models' Fokker D.VII double sided seat belts (132302),
'HGW Models' Sopwith Triplane detail set (132099) (two sets required),
'RB Productions' Fokker D.VII radiators (RB-P32031),
'Proper Plane' Heine 1:32 scale wood propeller with REXx exhaust,
'Steve Robson' hand made spoked wheels.

Engine

'Taurus Models' engine intake manifold lock rings (3211),
'Taurus Models' engine fuel priming cups (3219),
'Taurus Models' engine complete timing gear - conical valve springs (3209),
'Eduard' Swordfish hinge and panel set (32204),
'RB Productions' British wire terminals (RB-P32013).

Engine parts - 3D printed

'Flugzeugwerke' (Bob Monroe) (printed by 'Shapeways')
Mercedes D.III Oil Pump,
Mercedes D.IIIa Cylinders (hollow),
Mercedes D.IIIa Crankcase and engine block,
German Aircraft Magnetos,
Mercedes Cylinder clamps,
Gun synchro mechanism.

Aircraft structural parts - 3D printed

'Aviatic' (Richard Andrews) Fokker D.VII structure (3D printed by 'Shapeways').

Rigging accessories

'GasPatch' Elite Accessories 1:48th turnbuckles (Type C and Type 'one end'),
'Albion Alloy' micro-tube 0.4 mm (NST04) and 0.5 mm (MBT05),
'Steelon' mono-filament (0.12 mm diameter),
'Stroft' mono-filament (0.08 mm diameter),
'Infini Model' Medium 1:32 Aero Black Rigging (0.135 mm),
'Model Factory Hits (MFH)' Black Colour Tube (0.4 mm P-961).

Sundries

'Tamiya' acrylic, 'Humbrol' acrylic, 'Mr Metal Colour' enamels,
'AK Interactive' primer and micro-filler (Grey AK-758),
'AK Interactive' acrylic paints, 'Mr. Colour' levelling thinners,
PVA Adhesive, Cyanoacrylate (CA) glue (thin), 'Araldite' two part epoxy adhesive,
'Fleky 5' CA adhesive, 'Deluxe Materials' perfect plastic putty,
'Flory Models' sanding and polishing sticks, 'PlusModel' lead wires,
'Blacken-It', 'T-Force' XPS 0.148 mm line, 'Milliput' two part putty,
2 mm clear plastic tubing (1 mm internal bore), 'Bare-Metal' matte Aluminium foil.

Display Base

Online vendor built Acrylic base/cover and etched plaque (information plates),
'Coastal Kits' Abandoned Airfield mat (1:32 scale), 'Polak' Wild Meadow grass mat (4706).

THE MODEL (General)

(Donor kit - Wingnut Wings Kit No.32030)

This particular model kit is of Fokker D.VII (OAW built), which is a 'skeletal' version showing the internal structure of the aircraft, including details of the engine, controls, rigging and cross bracing. The structural components are 3D printed by 'Shapeways', based on designs by 'Aviatic'. The engine also has 3D printed parts by 'Shapeways', designed by 'Flugzeugwerke'. The remaining components are from the 'Wingnut Wings' Fokker D.VII kit (Kit No: 32030), although any of the 'Wingnut Wings' kits of the Fokker D.VII can be used as donors.

Donor kit:

As expected, any model from WingNut Wings (WNW) is at the top of quality and accuracy. The parts are manufactured from traditional styrene (plastic), not resin. Some of the kits sprues are common to all of the different kit versions of this aircraft and many of the parts are not required for this model. The primary donor parts required from the kit are those of the cockpit, wing struts, tail plane support struts, tail skid, some engine components and radiator.

The instruction manual is in the well known format that WNW produce and has clear and concise instructions, including coloured illustrations and photos for reference. Also the manual contains reference information and photographs about the aircraft.

After market:

The 3D printed components from 'Shapeways' are created a fine acrylic material, which gives good detail with no mold seams and 'flash'. The material used is a matte translucent plastic. Although 3D printing has come a long way, the surface of these still have visible layers, but which should be covered once primed and painted. It is recommended on the 'Shapeways' web site that these parts are carefully washed before being used.

The after market components for this model are from various companies:

- Aircraft structure - 'Aviatic' (3D printed by 'Shapeways').
- Engine components - 'Flugzeugwerke' (3D printed by Shapeways').
- Engine components - 'Taurus Models'.
- Pilot seat and cushion - 'Aviatic'.
- Seat harness - 'HGW Models'.
- Machine guns - 'Gaspatch'.
- Radiator photo-etch - 'RB Productions'.
- Wheels - 'Steve Robson' (hand crafted).
- Turnbuckles (rigging) - 'GasPatch' Elite Accessories.
- Rigging - 'Albion Alloy' micro-tube, 'Steelon' and 'Stroft' mono-filament.
- 'Heine' laminated propeller - 'Proper Plane' (hand crafted).

Scratch built:

Some parts for this model will need to be scratch built, such as the undercarriage axle and fairing assembly.

Detailed information for the build, including after market parts and scratch building is covered in the subsequent Parts of this build log (refer to the contents page).

Aftermarket

The following photograph shows the 'Aviatic' 3D printed structural components from 'Shapeways'. These comprise the fuselage (from cockpit rearwards), upper wing (3 parts), lower wing (2 parts), fin, tail plane, tail skid, rudder, elevator and ailerons. The only structural assembly not produced is that of the undercarriage axle/fairing assembly, which if desired will need to be scratch built.

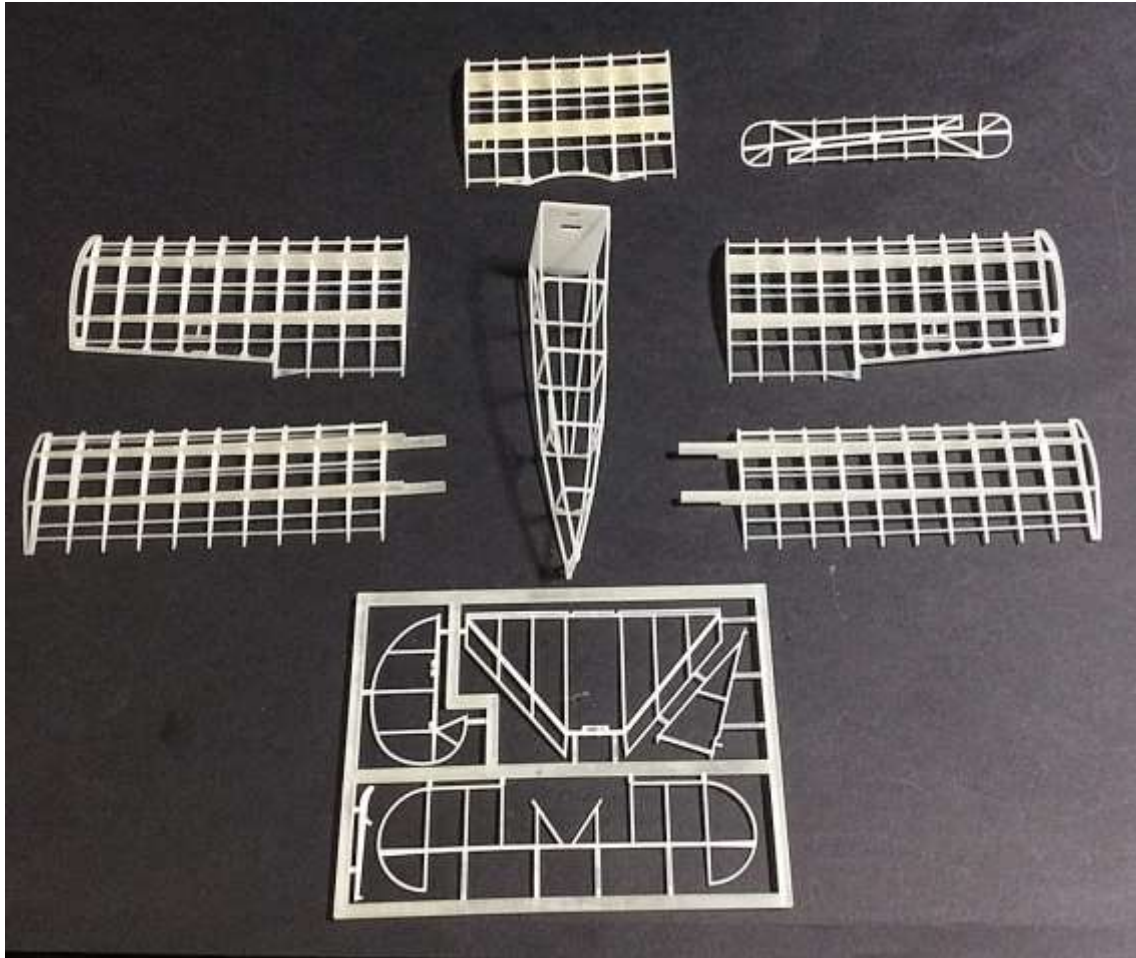

The following CAD photographs show the various 'Flugzeugwerke' 3D printed components printed by 'Shapeways' for the Daimler-Mercedes 180hp D.IIIa engine used for this model.

Engine block

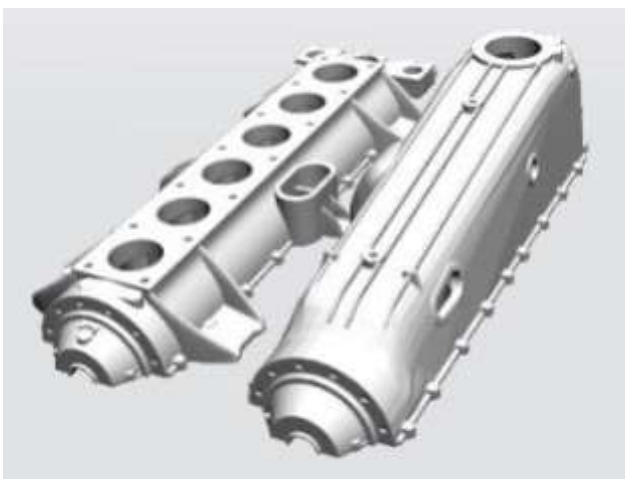

Cylinder base - clamps

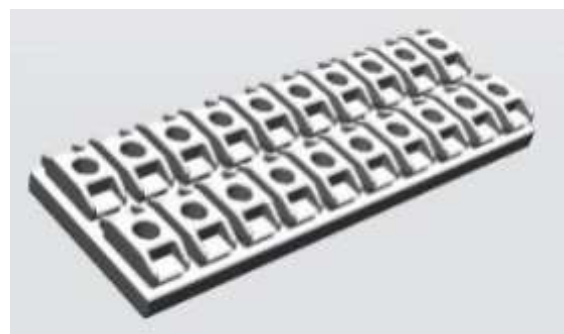

Piston cylinders

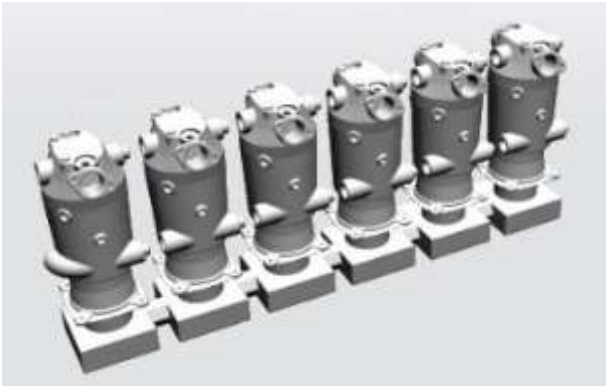

Oil pump

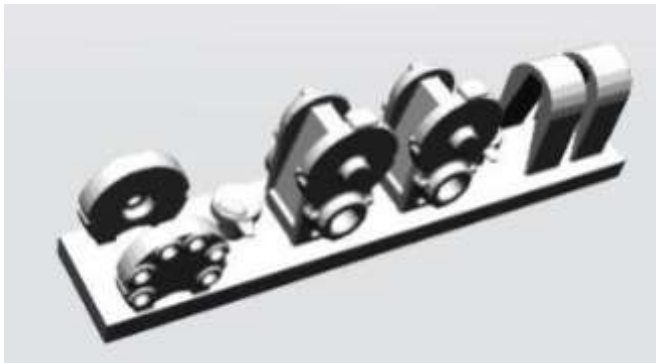

Twin Magnetos

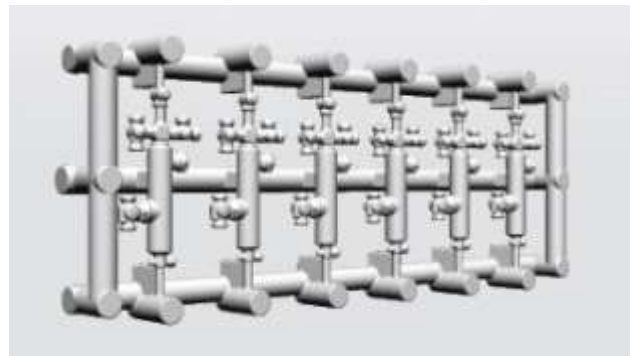

Fuel control valves



Gun synchro mechanism

The following photographs show the pilots seat and engine fuel primers from 'Aviatic'.



The following photographs show the basic propeller and mounting boss from 'Proper Plane' and the REXx exhaust.



The following photographs show the engine components from 'Taurus Models'.



The following photograph shows the fitted photo-etch radiator grills from 'RB Productions'.

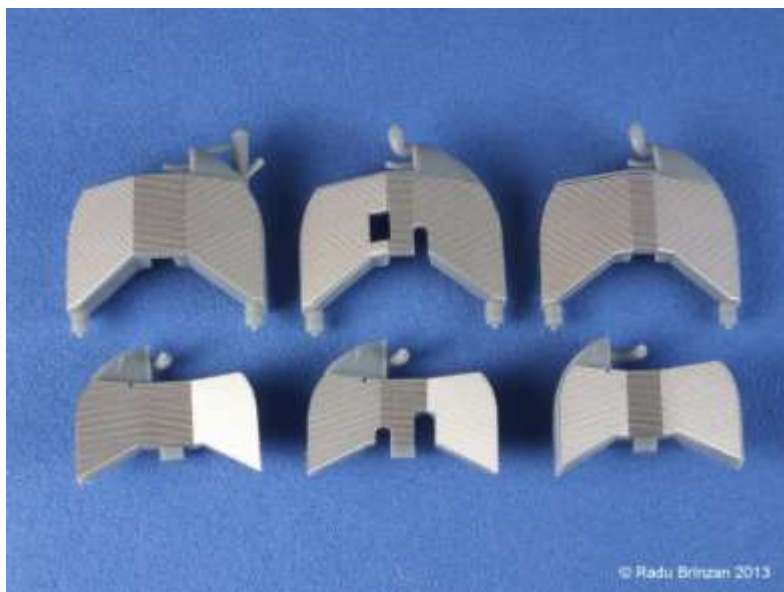

The following photographs show the hand crafted wheels (with rubber tyres) by 'Steven Robson'.



The following CAD photographs show the machine gun and 1:48th scale turnbuckles from 'Gaspach Elite Accessories'.

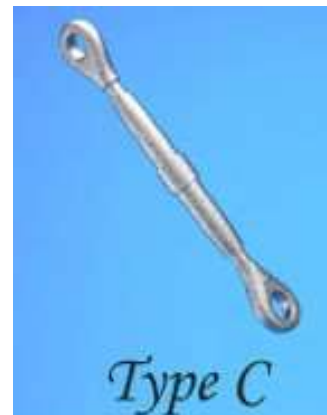

The following photographs show the fabric seat harness from 'HGW Models'.

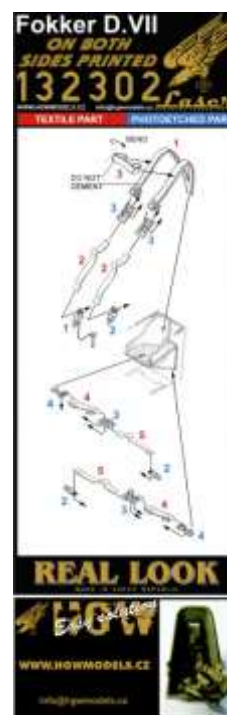
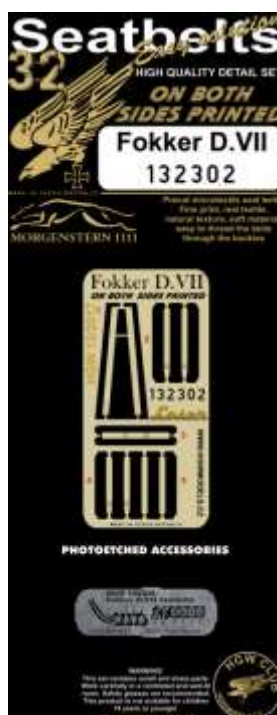

THE AIRCRAFT

This model represents a 'skeletal' Fokker D.VII (OAW built).

NOTE: *This model will be displayed, with associated figures, alongside the model of the Fokker D.VII (Albatros built), 'Nickchen IV' (Little Nick), Serial No.817/18 operating with Jasta 53 during August 1918 and flown by Fritz Blumenthal, .*

References:

Osprey Aircraft of the Aces - Fokker D.VII aces Part 1-2 (Norman Franks/Greg VanWyngarden).
Albatros Productions - Windsock - Data file No.9 - Fokker D.VII (P.M. Grosz).
Albatros Productions - Fokker D.VII Anthology 1, 2 and 3 (Ray Rimell).
Kagero Publishing - Fokker D.VII The Lethal Weapon (Tomasz J. Kowalski and Marek Rys).
Wingnut Wings - Instruction manual (Kit No.32027).
Windsock Modelling Special No.3 - Building the Fokker D.VII (Ray Rimell).
Various online resources (e.g. Wikipedia and the Aerodrome forum).
Albatros D.III - Osprey Publishing (James F. Miller).

Design:

Fokker's chief designer, Reinhold Platz, had been working on a series of experimental V-series aircraft, starting in 1916. The aircraft were notable for the use of cantilever wings. Junkers had originated the idea in 1915 with the first all-metal aircraft, the Junkers J 1, nicknamed Blechesel (sheet metal Donkey or Tin Donkey). The wings were thick, with a rounded leading edge. The shape of the wings aerofoil section gave greater lift and more docile stalling behaviour than the thin wings commonly in use. Late in 1917, Fokker built the experimental V 11 biplane, fitted with the standard Mercedes D.IIIa engine. In January 1918, Idflieg held a fighter competition at Adlershof. For the first time, front line pilots participated in the evaluation and selection of new fighters.

Fokker submitted the V 11 along with several other prototypes. Manfred von Richthofen flew the V 11 and found it tricky, unpleasant and directionally unstable in a dive. Platz lengthened the rear fuselage by one structural bay and added a triangular fin in front of the rudder. Richthofen tested the modified V 11 and praised it as the best aircraft of the competition. It offered excellent performance from the outdated Mercedes engine, yet was safe and easy to fly. Richthofen's recommendation virtually decided the competition but he was not alone in recommending it. Fokker immediately received a provisional order for 400 production aircraft, which were named D.VII by Idflieg.

Fokker's factory was not up to the task of meeting all D.VII production orders.

The Idflieg directed Albatros and AEG to build the D.VII under license, though AEG did not ultimately produce any aircraft. Because the Fokker factory did not use detailed plans as part of its production process, Fokker simply sent a D.VII airframe for Albatros to copy. Albatros paid Fokker a five percent royalty for every D.VII they built under license.

Albatros Flugzeugwerke and its subsidiary, Ostdeutsche Albatros Werke (OAW), built the D.VII at factories in Johannisthal (Fokker D.VII-Alb) and Schneidemühl (Fokker D.VII-OAW) respectively. The Fokker D.VII soon became recognised as the best German fighter of the war and in fact the Treaty of Versailles specifically called for the surrender of these aircraft to the victorious Nations involved. In total approximately 3,380 Fokker D.VII aircraft were built by the various companies, of which approximately 1100 were built by OAW.

The basic aircraft statistics are:

Wingspan - 8.7m (28.54ft)

Length - 6.95m (22.8ft)

Maximum weight - 880kg (1,940 lbs)

Maximum speed - 200kph (124mph)

Operational ceiling - 6900m (22,600ft)

Weapons - two 7.92mm LMG 08/15 'Spandau' machine guns

Engine - Daimler-Mercedes180hp D.IIIa or 200hp D.IIIaü

PART 1 - PARTS PREPARATION

Donor kit:

As for the 'Wingnut Wings' donor kit, some modellers work the various pieces whilst they are still attached to the main sprue, but I prefer to remove the pieces first so that I can clean them up more easily. Care needs to be exercised when removing some parts, such as the cockpit frames, wing struts and engine bearer frames, which are delicate and can easily be damaged when being removed. When parts are cut from the sprues, care should be taken as they can either break or get stressed at the cut point, which causes 'white' stress and/or deforming. For plastic kits, I use fine sprue cutters to cut away the kit part, not too close to the part, then sand off the tag. For cutting away resin parts from their mold blocks, I use a fine cutting saw, which has a more gentle cutting action. Despite the quality of 'Wingnut Wings' kits, there are still some fine moulding lines around items such as the cockpit frames, but they are only slight and are easily removed using a sharp blade or sanding stick. I use a new scalpel blade to gently scrape off the mould lines. Some of the model items like the parts for the cockpit are very small and can easily 'fly off' when being handled, so take care. Remember to drill any holes needed for rigging or control lines by referring to the relevant pages and diagrams in the kit instruction manual. Once the items have been removed from the sprue and prepared, I normally gently wash them in warm, soapy water, to remove any handling 'grease' or mould release agent remaining on the items. I use an old toothbrush to do this. Once dry they can be primed ready for painting. Primer can be applied by brush, airbrush or from aerosol cans. These days I prefer to use 'AK Interactive' Primer and Micro-filler (Grey AK-758) or (White AK-759). These have good coverage as the base primer for acrylics. Take care when spraying the primer as if you apply too much it will result in 'pooling' or 'runs', which would then need to be removed once the primer has dried. Make sure you spray in a well ventilated area or preferably, if you have one, use a good extraction booth.

3D printed components:

The parts need to be cleaned before use. The following is an extract from the 'Shapeways' web site for cleaning prior to painting:

NOTE: *Two different methods for cleaning are recommended. I chose what I considered to be the safer of the two, which was using the washing liquid.*

"To prepare the parts for painting, scrub them with a toothbrush in ordinary dish washing liquid and rinse thoroughly, or soak them for up to 5 minutes in a small jar filled with acetone (nail polish remover.) Once the waxy support material is completely removed, the parts will appear white wherever support material was needed during printing. We recommend carefully sanding these white areas with a sharpened fine grade sanding stick (or similar) to remove the texture caused by the support material. With care this can be done without spoiling the details".

PART 2 - WOOD EFFECTS (General)

A basic technique:

Parts of the model that are supposed to be made of wood can prove to be a challenge to replicate a wood finish to the part. Some after market companies produce accurate wood decals, which can be used to cover larger areas, such as cockpit decking and fuselage panels. However, decals can't easily be used to create realistic wood finish to smaller items or parts that don't lend themselves to having decals applied. To do this requires brush painting, using such as acrylic or oil paints, which can be enhanced with various washes or filters.

The first thing to do is to ensure the model parts are cleaned, normally with warm water with washing up fluid and something like an old tooth brush. Once cleaned and thoroughly dried, the primer coat can be applied. I use 'Tamiya' Aerosol Light Grey (Fine) or White (Fine) acrylic primer. Once the primer is dry, you can start applying the wood effect to the applicable cockpit items, such the cockpit framework, decking, seat supports, rudder bar, instrument panel and of course, the wing struts. With practice, this method can also be used on fuselage panels and propellers.

To start, apply a suitable base colour. For most painting I use an airbrush and only resort to brush painting when dealing with small items, when I add a few drops of 'Mr. Colour Levelling Thinner', which aids brush painting. For most wood effect, I use 'Tamiya' Deck Tan (XF55) or Dark Yellow (XF60), suitably thinned with 'Tamiya' Thinners (X20A). Allow this base coat to fully dry (if you can't smell the paint, then it's dry).

Example of base coat using 'Tamiya' Wooden Deck Tan (XF78).

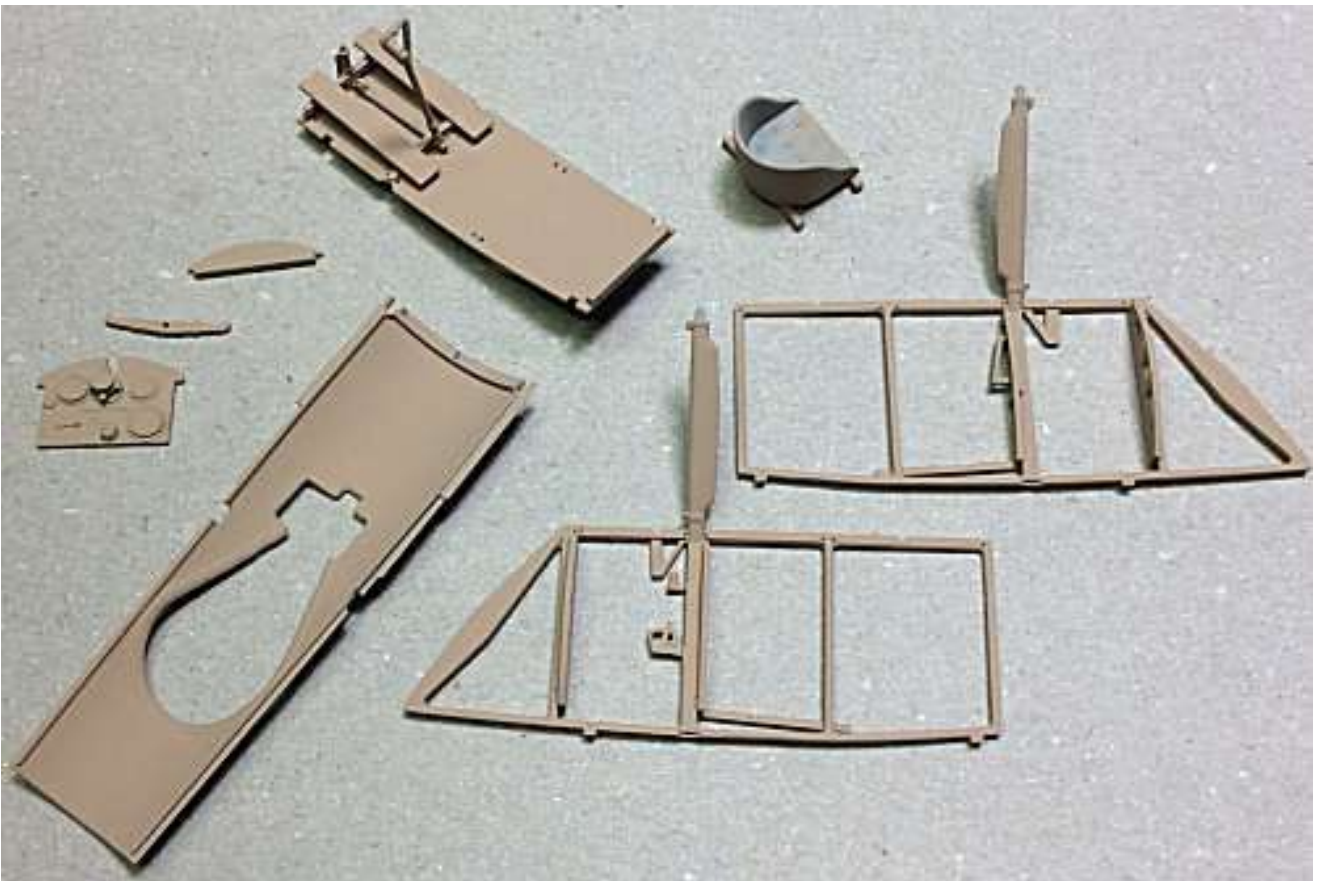

For the next step I use 'DecoArt Crafters Acrylic' (water based) oil paints, either Burnt Umber or Burnt Sienna. These are similar to standard acrylic oil paints, but are water based instead of oil based. This paint is not as thick as oil based paint and is more creamy, so can be brushed and controlled more easily. Also, as it is water based, it's easy to clean your brushes, and if really necessary, can be thinned slightly with water. In addition, the paints dry as quickly as normal acrylic paints, avoiding the disadvantage of using true oil paints, which can take days to fully dry.

Place a small amount of the oil paint onto a non-absorbent surface and using a suitable oil paint brush (I use a slightly curved brush), wipe a small amount of the paint onto the brush. For larger areas, such as decking or panels etc I use a small piece of fine sponge to apply the paint.

Apply the paint to the applicable item, using light strokes and in the required direction. Apply the paint along struts and across instrument panels and other smaller items. This gives variation to the wood effect and for the wing struts, is correct for the direction of the wood grain. If you apply too much paint, just brush or sponge it off immediately before it dries. Although the paint is water based, don't try to thin any applied paint with water as it will lift the paint, which builds up into clumps. If required, a second light coat can be applied. Always wait until a first coat has fully dried before applying a second coat, otherwise the first coat will 'drag' and lift from the surface.

Once painting is complete, clean the brush in water.

Below is an example of the Burnt Sienna oil paint applied to a cockpit side frame.



Once the oil paint layers have dried, the final top coats can be applied to give the final effect of varnished wood.

Tamiya' have 'Clear' coloured Acrylic paints, which are intended to be mixed with either Flat Clear (XF86), Semi-Gloss Clear (X35) or Clear (X22), to give the required finish but with a tint of the added 'Clear' colour. I use the Clear Yellow (X24) or Clear Orange (X26) to add a varnished tint to the clear coat. However, I don't use the 'Tamiya' Clear, but instead use Alclad Light Sheen (ALC-311). Although it's a lacquer, I've found that it will accept 'Tamiya' 'Clear' coloured Acrylics without any separation, which can happen with other paints. The Alclad lacquers dry fast and provide a good sealing layer over the painted surfaces. When using Alclad sealing coats, the golden rule is to allow the various painted surfaces to dry fully before applying Alclad lacquers.

In this example, I added a few drops of Clear Yellow (X24) into the Alclad Light Sheen (ALC-311) and thoroughly mixed it. Only add small amounts to the Alclad in order to control the amount of tint you desire. I increased my airbrush air pressure to around 20 psi to airbrush the sealing coats over the various cockpit items. The first coat usually dries to a more matte finish, which I assume is due to being sprayed onto the oil paint, rather than onto straight acrylic paint. Once this first coat has dried, I airbrushed several coats of just Alclad Light Sheen (ALC-311), which added not only more sealing coats, but more importantly gave the desired semi-gloss 'varnished' finish I was after.

Below is an **example** of the applied Alclad lacquer/X24 mix on the propeller.



NOTE: *Once you are confident using this method of replicating wood finishes, you can vary both the colour of the acrylic base coat and tinting of the sealing coat, to replicate other types of wood used in aircraft construction.*

Once the lacquer coats are thoroughly dry, any detail painting, decals or final weathering can be applied to the parts, as required, prior to fitting them to the model.

PART 3 - WEATHERING (General)

Flory Model clay washes: These washes come in various shades and consist of a very fine clay pigment. They are brushed over the surface to be weathered and dry in around 30 minutes. When dry, use either a piece of good, absorbent kitchen roll or a brush used for oil paint (as the bristles are harder than normal painting brushes) to remove as much of the clay wash as you need to achieve the desired effect. Once dampened, the dried clay is re-activated and the clay wash can be removed or worked as required.

First I seal the surface with airbrushed a semi-matt sealer, such as 'Alclad' Light Sheen (ALC-311), which dries quickly. A gloss coat tends to stop the clay wash 'gripping' the surface when it is applied and it can run off or just puddle. A matte coat can cause the clay wash to 'grip' too much, making it very difficult to remove or even to wash it off completely.

To apply the clay wash is just a matter of brushing all over the surface to be weathered. It doesn't matter really how much is applied as it can be left on for any period, as it is easily removed without any effect on the surface underneath. The washes I tend to use are Flory Clay Wash 'Grime' and 'Dark Dirt' .

I use a still oil brush to brush off the clay wash, but for smearing effects, an only very slightly damp brush or absorbent paper can be used, but even then I dab them onto a dry piece of the paper. That's how 'damp' it needs to be. Any wetter and you'll find that you are removing too much of the clay wash. If that happens you would have to re-apply the wash and start again.

That said, if you not happy with the final effect, you can easily remove the clay wash by brushing with a wet brush or even airbrush water over the surface. Dry off the surfaces washed and then re-apply the clay wash and try again until you are satisfied.

The technique is to brush over the surface to re-activate the clay wash and at the same time, to smear it over areas that had no clay wash. It'll dry more or less straight away.

Then I'll very lightly stiff brush and/or use a piece of damp absorbent paper or brush to remove as much as I want until I get the desired effect. If I remove too much I just reapply clay wash to that area and repeat the removal procedure.

Once finished, just run the brush under a tap to rinse out any residual clay pigments.

Finally I airbrush an appropriate sealer over weathered areas, which seals the applied clay wash.

NOTE: *Flory washes can be mixed to create other colour blends.*



Chipping effects:

To achieve the effect of chipped paint etc, various methods can be used by using a chipping fluid, hair spray or by 'dry' chipping. To achieve this effect, first prime the areas with, for example, 'Tamiya' Fine surface primer (Grey) then airbrush a suitable metallic colour, such as 'Tamiya'

Aluminium (XF16) or 'Alclad' Duraluminium (ALC-102). Once dry apply a chipping fluid, such as 'AK Interactive' Medium Chipping fluid (or Vallejo chipping fluid) or a cheap hair spray and when dry, top coat with the required colour. Once fully dry moisten the top coat with water, which will soften the paint. Then with a cut down (stiff) brush and/or wood cocktail stick, gently tease off the top coat paint. Take care when doing this as 'too much chipping' can't really be covered up. In that event you would have wet the top coat and remove it all with an old toothbrush or similar and then when dry, re-spray the top coat and try again. Once the desired effect is achieved, seal the surfaces with an airbrushed coat of sealer, for example 'Alclad' Light Sheen (ALC-311).

The 'dry' chipping method relies on chipping away the top coat of paint from the base metal colour. This method does not require chipping fluids or hair spray to be pre-applied, but really only works when using acrylic paints, which dry 'softer' than lacquer paints.



'Tamiya' Weathering Master sets: Each of these 'Tamiya' produced weathering sets contain three 'tablets' of different colours and an applicator, which has a brush on one end and a sponge on the other. The tablets have a wax look and feel and can be applied onto painted surfaces to reproduce various finishes. It's best to use these as the final surface treatment, as being a 'Wax', any treated surfaces can't be painted or sealed.



Pigments: Pigments, such as those produced by 'Flory Models' or 'Humbrol' are effectively very fine 'dusts', which can be applied to a model to re-create dust, dirt, stains etc. They can be applied by dry brushing or mixed with other mediums to create paintable solutions.



Washes: Washes can be applied to either enhance panel lines etc or to add a 'filter' of colour onto a painted surface. They can be purchased ready made from various manufacturers or can be 'home made' using such as oil paints with a suitable thinning agent. I tend to use 'AK Interactive' products.



Oil paint: A technique used more frequently now is oil paint 'dot and drag'. Basically an oil paint of the desired colour is placed onto a piece of cardboard, which over a hour or so, soaks out the oil in the paint, leaving a drier pigment. The pigment is 'dotted' onto the painted surface where it is required then dragged with a brush previously wetted with 'Tamiya' X20 enamel thinners then wiped virtually dry.

Softly 'flick' the brush to drag the oil paint in the direction required, which will blend it in a thin layer.

The amount of oil paint left showing depends on the effect you require. Always keep the brush wiped clean to avoid a build up of oil paint and remoisten and wipe dry often. The more paint you drag, the less is left showing. Blending different coloured oil paints can create stains from smoke/gun blast, rain marks/runs, dirt/dust and oil/fuel stains.

A good quality oil paint and thinners are essential to produce a good finish. Some quality oil paints can be too 'gritty' when leached of oil, so I use 'Abteilung 502' oil paints and 'Tamiya' Enamel thinners (X20).



Similar results can be obtained by using the oil brushers and enamel odourless thinners (2019) from 'MiG'.

PART 4 - DECALS (General)

Whilst only the cockpit instrument decals supplied in the kit will be used for this model build, it's worthwhile to explain the basics of applying decals to a model..

'Silvering' explained:

The term 'silvering' is given to areas of an applied decal that have a dry, silver appearance. 'Silvering' is caused by air being trapped under the decal during application. This air builds up around 'imperfections' on the model's surface, such as dust and surface or paint imperfections. As the applied decal is drying, any air trapped under the decal prevents the decal from adhering to the model surface. Once the decal has set, the area of decal kept off the model surface by the trapped air will have dried out, producing a 'silver' effect. This is more evident under the clear carrier film of the decal, but can also occur under coloured areas. Although decal setting solutions help to conform decals to the model surface, 'silvering' will occasionally occur, no-matter how much care is taken in surface preparation. If 'silvering' has occurred under a set decal, all is not lost. The affected area of the decal can be carefully pin pricked and more decal setting solutions applied. The solution should penetrate through the pin pricks, filling the void and expelling the trapped air. The decal should conform to the model surface with the 'silvering' removed or at least reduced.

Traditional decals:

Traditional decals are normally created for the particular model markings using processes such as silk screen printing and are pre-shaped ('cookie cut'), which means the carrier film covers only the decals, not the entire decal sheet. When placed in warm water they will detach from the backing sheet and can then be slid onto the model surface. Once correctly positioned they are wiped with a semi-dry brush or cotton bud etc, to expel any water from under the decal. When fully dry, decal softeners, such as 'MicroSol' and/or 'MicroSet' can be applied, if necessary, to 'weld' the decal to the model surface. Finally a sealing coat of acrylic or lacquer gloss, semi-matt or flat is applied over the decal, to seal and protect the decal.

Applying 'standard' decals to painted surfaces:

NOTE: *The following is applicable only for decals on a painted surface. If decals are to be placed on top of previously applied decals, the decal setting solutions may 'eat' into the previous decals. In this case a gloss sealing coat should be airbrushed over the first decals, to provide a barrier against the setting solutions.*

Applying 'standard' water slide decals to a painted surface is different to that for 'Aviatic' decals.

1. Ensure the painted surface is smooth and free from any surface imperfections.
2. Airbrush **several light** sealing gloss coat finish, to provide a smooth and glossy surface.
NOTE: *'MicroSet' solution softens the decal to allow it to conform to the painted surface. Do not attempt to move the decal too much or it may tear.*
3. Wet the area using a light coat of 'MicroScale' **MicroSet** solution.
4. Apply the decal after it has soaked in 'warm' water enough to start to loosen the decals from its carrier backing.
5. Carefully move the decal into the correct position.

6. Carefully press out any residual water from the decal by either pressing with a tissue or by gently rolling over the decal with a cotton bud.
NOTE: *'MicroSol' solution will soften the decal to allow it to conform fully to the painted surface. The solution usually causes the decal to wrinkle, but this is normal as the decal semi-dissolves to the surface. Once the solution has been applied, never try to disturb the decal as it will tear. Leave the solution for several hours to do its job, after which the decal will return to a smooth surface, but conformed fully to the painted surface.*
7. Wet the decal surface with a light coat of 'MicroScale' MicroSol solution.
8. Leave the solution for several hours to fully dry and set the decal.
9. Once fully dry and set, airbrush a sealing coat over the decal, dependant of your desired finish. I tend to use either 'Alclad' Light Sheen (ALC-311) lacquer or 'Tamiya' Semi Gloss (X35).

PART 5 - RIGGING (Description)

The first thing to check is that you have already drilled out the rigging attachment points. Most models have these located on the model, but it's best to carry out research in reference books or research on line before drilling.

Some modellers use micro drills manufactured for drilling printed circuit boards etc and these drill bits sometimes have identifying coloured collars fitted to the drill shanks. I have found that care needs to be taken when using these drills, as they are sharp and instead of easing their way into the plastic of the model, they tend to bite in and effectively 'cork screw' their way in, which causes jamming and lots of broken drills. This is not only expensive but can leave broken drill bits in the model, which are virtually impossible to extract. An alternative is to use High Speed Steel (HSS) drill bits, which are cheaper and have less 'bite' when in use, although again, they are very fragile and can very easily be broken.

Some modellers drill through the wings etc of the model and rig by pulling through the rigging line/EZ thread etc, gluing in position and then rubbing down the exposed line 'tag' and re-painting that area. I prefer to drill only part way into the plastic and attach the applicable rigging fixture with CA adhesive.

With your research complete and all necessary holes pre-drilled, the rigging can start. For the primary I used 'Steelon' mono-filament (fishing line) of 0.12 mm diameter and for flight control I used 'Stroft' 0.08 mm diameter mono-filament. These are effectively transparent but do give a look of steel, without the need of painting or colouring with a gel pen.

NOTE: *As you work your way through the rigging it is always good to check the rigging attachment points for any damaged paint. This can be rectified before continuing with the rigging, just in case access will be limited once all of the rigging is completed.*

The Fokker D.VII was noted for its structural integrity and strength, being due to its design and in particular, the use of tubular metal frames. This meant that the aircraft had very little external rigging, although the internal structure was crossed braced to a high degree. German aircraft were rigged using 'standard' round section cable, which were tensioned by turnbuckles. As turnbuckles are not supplied in the kit, I used the 'GasPatch' Elite Accessories 1:48th turnbuckles (Type C and Type 'one end'), as these are more 'in-scale' than the 1:32 scale version, which appear to be slightly over-scale.

The methods used to fully rig the model are described later, during the construction phase. However the following information will assist in preparing the various model parts to accept the rigging. The basic rigging is for flight control and cross bracing

Flight control:

Aileron control cables:

NOTE: *The following explanation of the aileron control cable routing is partly based on supposition, due to a lack of information.*

The components for the control of the upper wing ailerons were a cockpit bell crank, fitted on the forward end of the control column torque tube and pairs of twin cable pulleys. Two sets of twin cable pulleys were fitted to the rear face of the upper wing rear spar, close to the where the rear inboard wing struts were attached. A second set of twin cable pulleys were again fitted to the rear face of the upper wing rear spar, but opposite to the two control horns of each aileron.

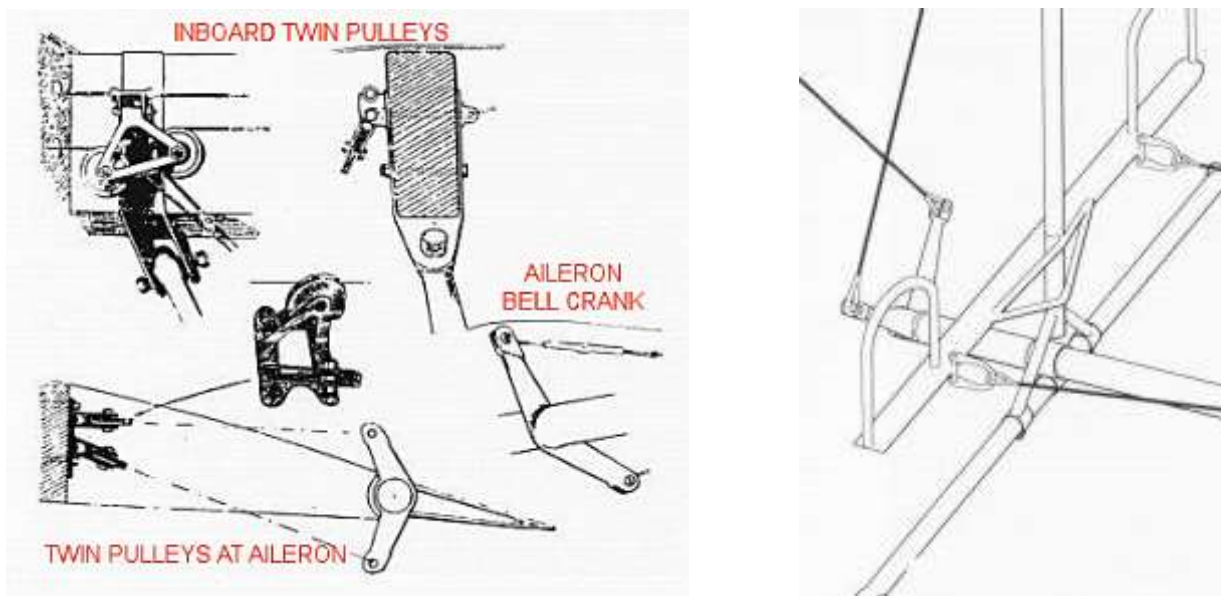

Twin aileron control cables were attached to the ends of the levers on the aileron bell crank and were then routed diagonally across each other and up between the forward ammunition container and the fuel tank to the opposite side of the fuselage. The cables were then routed through the fuselage and up into the upper wing, adjacent to the attachment for the inboard rear wing strut.



Inboard twin pulleys

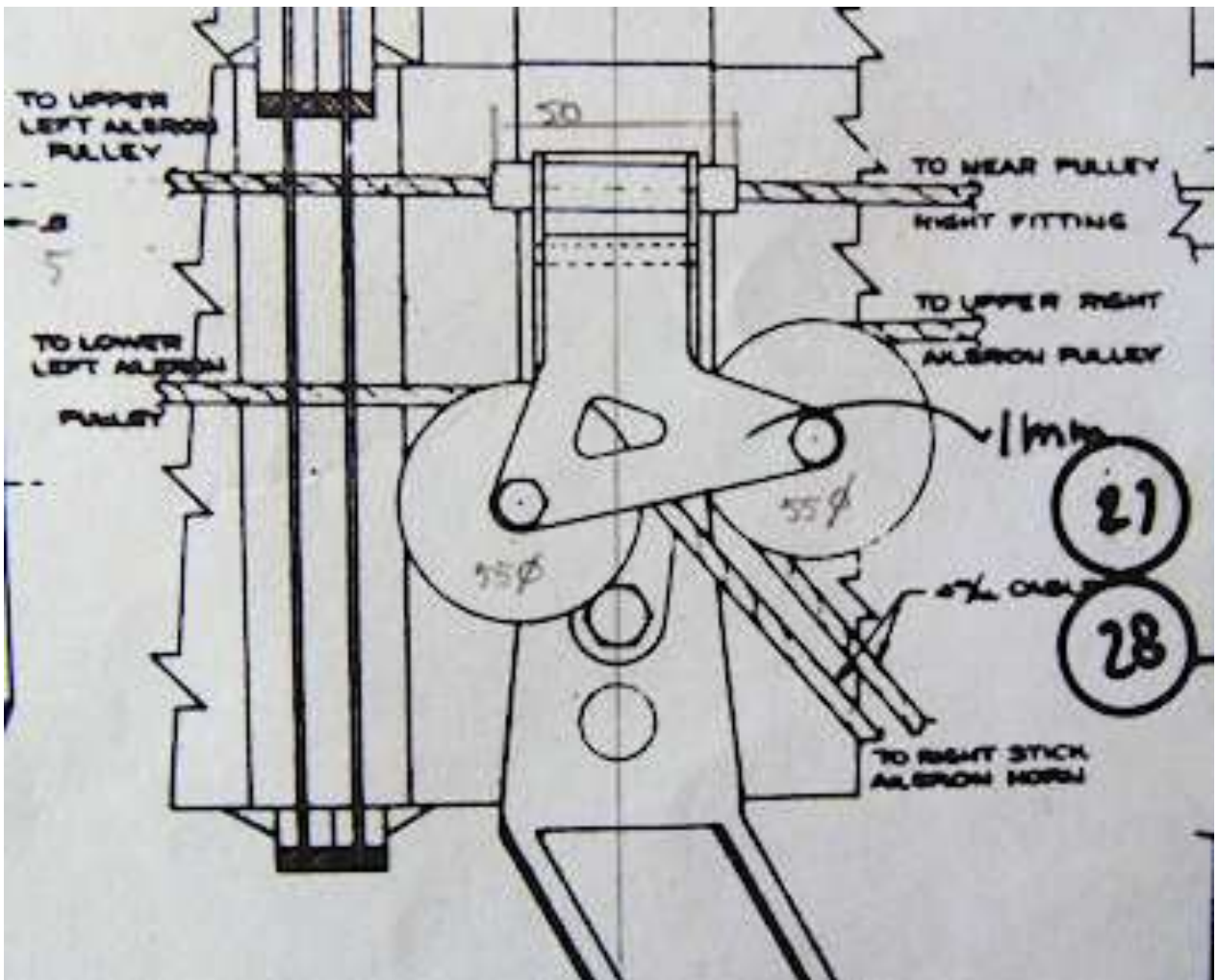
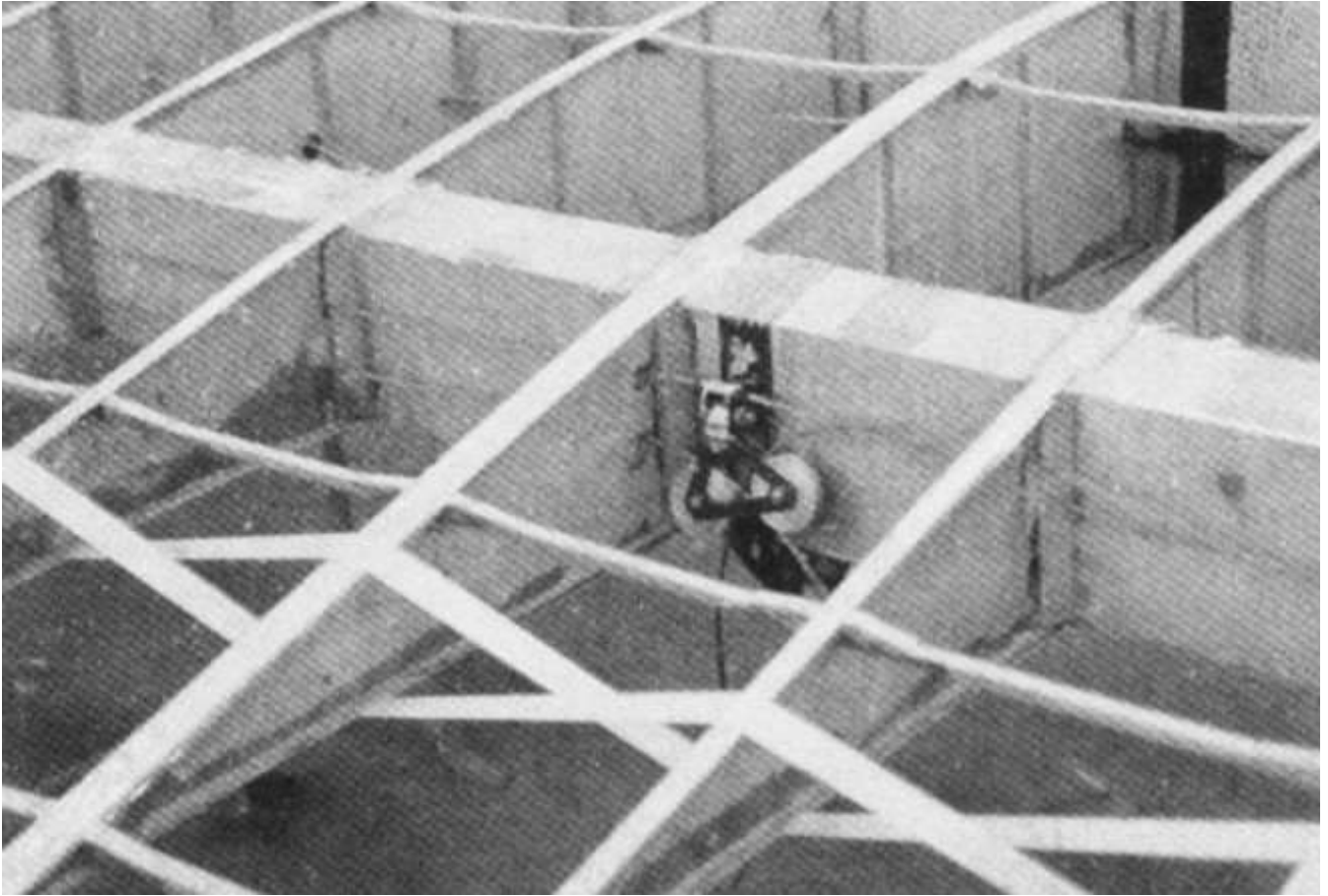

Twin pulleys at aileron

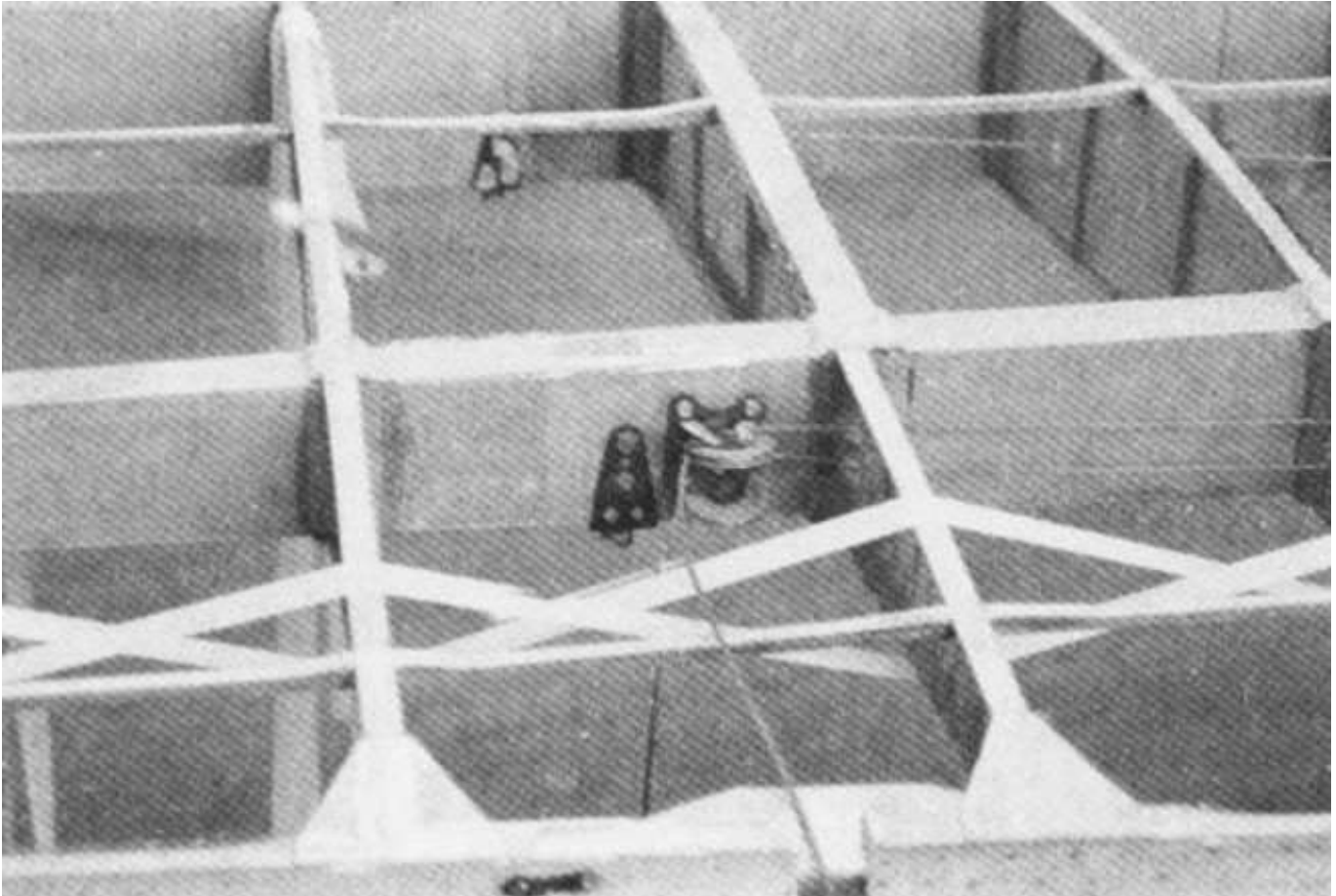

Left lever of the bell crank:

One cable routed around a right side inboard pulley on the wing spar then left and out around a left outboard pulley to the left aileron top control horn. The other cable routed around the other right inboard pulley then out right and around a right outboard pulley to the right aileron bottom control horn.

Right lever of the bell crank:

One cable routed around a left side inboard pulley on the wing spar then left and out around a left outboard pulley to the left aileron bottom control horn. The other cable routed around the other left inboard pulley then out right and around the other right outboard pulley to the right aileron top control horn.

NOTE: *The cables for the top control horns on the ailerons cross each other in the wing centre section and were routed through cable fairleads located on the top of the twin inboard pulleys.*

The control column was moved to the right to bank the aircraft to the right. This action rotated the aileron bell crank to the right. This put the twin cables attached to the right lever in tension to pull the left aileron down and the right aileron up. The twin cables attached to the left lever 'relaxed' and allowed the ailerons to move. The result was that the aircraft banked to the right.

When the control column was moved to the left, the bell crank rotated to the left and put the twin cables attached to the left lever in tension, pulling the left aileron up and the right aileron down. The twin cables attached to the right lever 'relaxed' and allowed the ailerons to move. The result was that the aircraft banked to the left.

The installation for the aileron control cables is covered later, during the construction of the model.

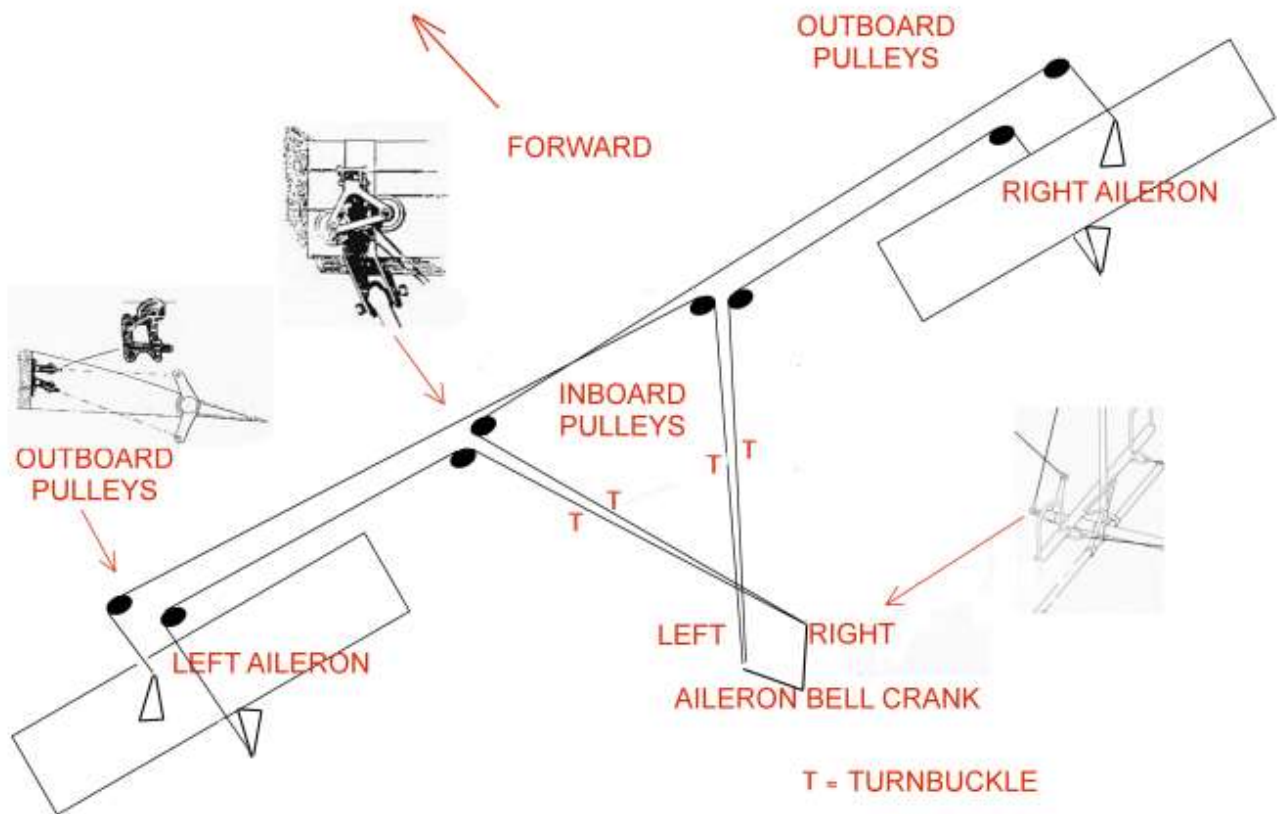

Rudder control cables:

The rudder was controlled by a single cable attached to each side of the rudder bar. The cables were routed rearwards under the pilots seat then through the seat 'bulkhead' to the rear of the fuselage, then out to be connected to a rudder control horn, fitted to the rudder pivot post. Movement of the pilots rudder bar would tension either the left or right control cable and cause the rudder to move in that direction. The control cable not under tension would 'relax' to allow the rudder to move.

Elevator control cables:

The elevator was controlled by four cables. Two were attached to the bottom of the control column and routed rearwards to be connected to the control horns on the top of the elevator. A second pair of cables were attached slightly higher on the control column and were routed rearwards and connected to the control horns on the underside of the elevator. These cables crossed inside the fuselage.

The installation for the rudder and elevator control cables is covered later, during the construction of the model.

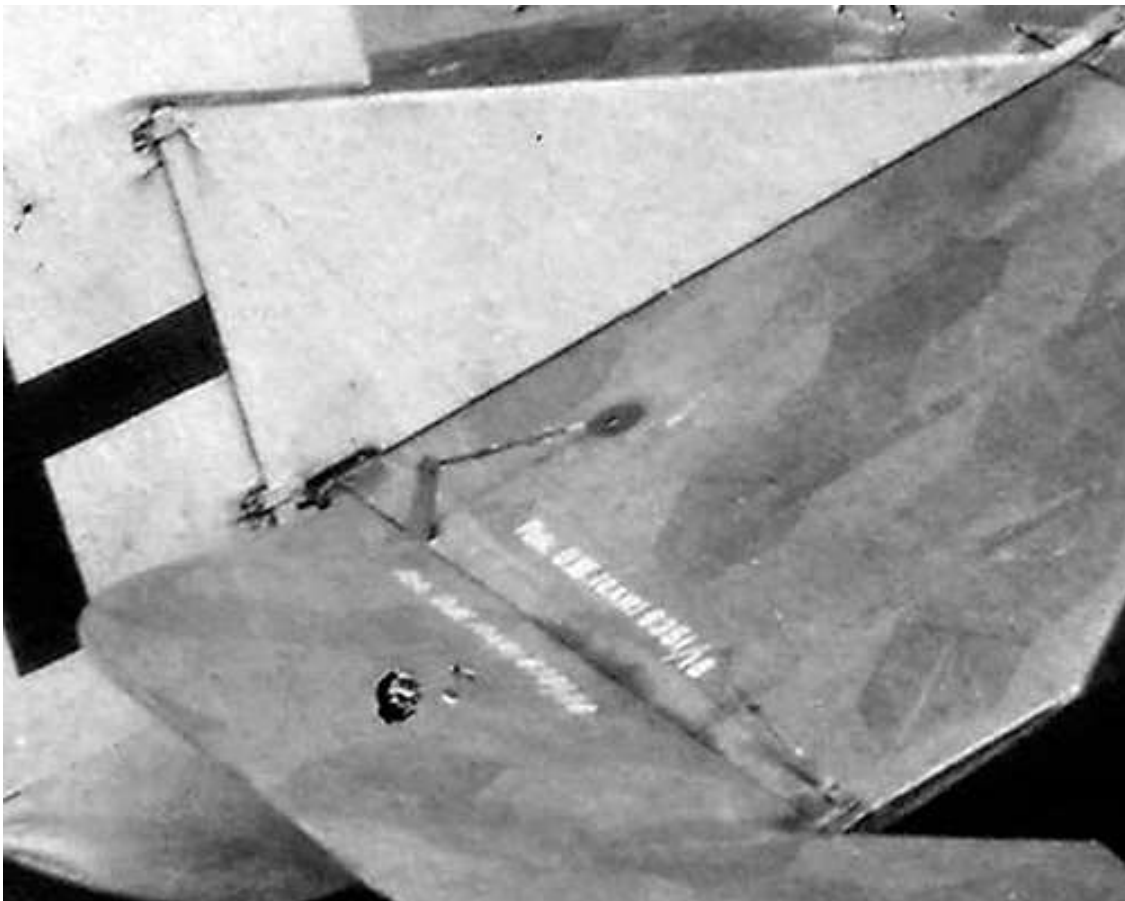
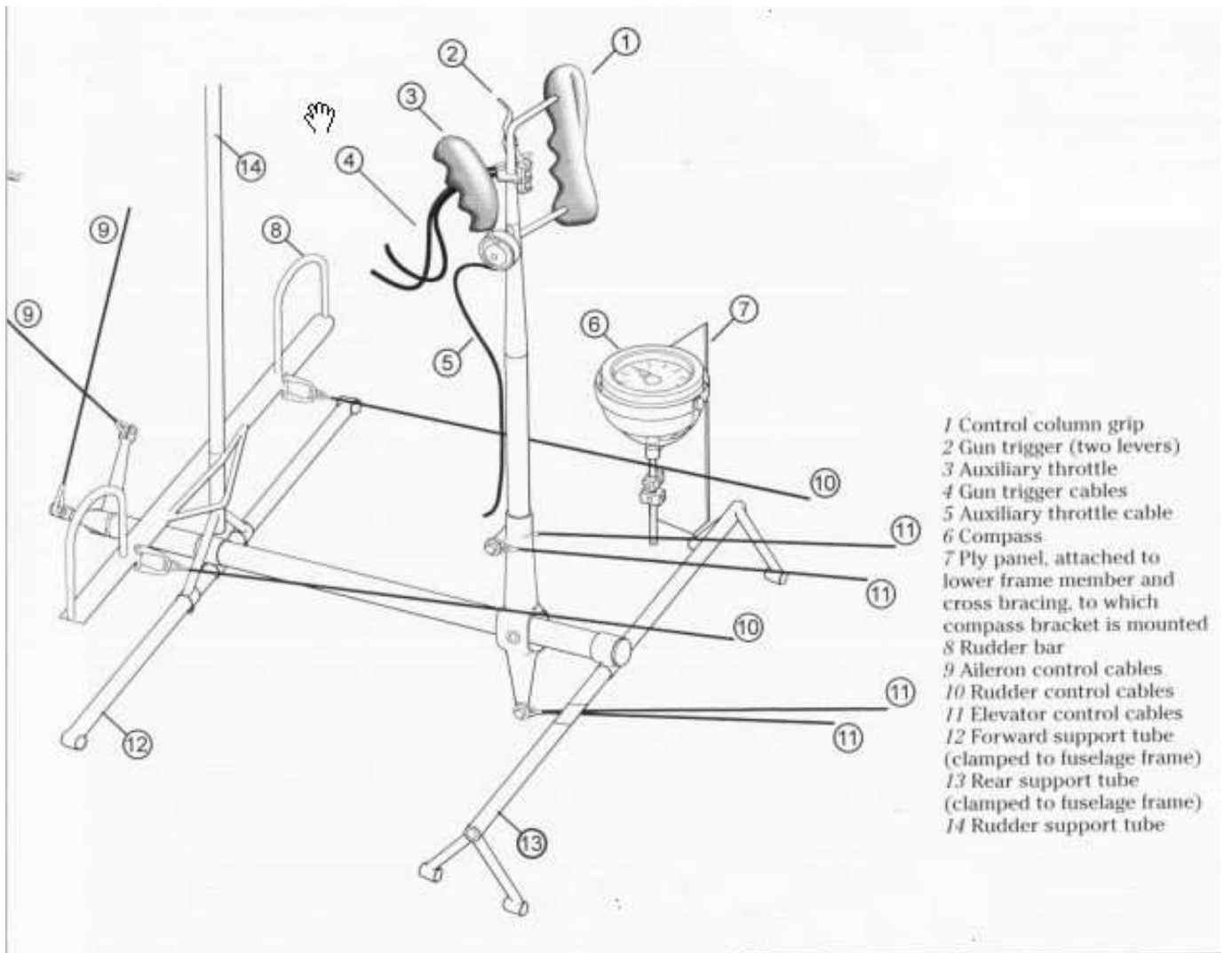

Cross bracing:

The aircraft cross bracing cables were fitted to the undercarriage and tail plane to fin, but mostly for bracing the aircrafts internal wing and fuselage structure.

NOTE: *The actual cross-bracing cables will be fitted later in this build.*

Undercarriage:

Cross bracing cables were fitted to the undercarriage, diagonally between the top and bottom of the forward undercarriage struts. Turnbuckles were fitted at the bottom of each bracing cable.



Tail plane to fin:

The tail plane was braced to the fuselage by support struts underneath the tail plane. Above the tail plane was braced by a cable, routed from the outer trailing edge of the tail plane and through the fin, just below the upper rudder hinge. Turnbuckles were fitted to each bracing cable.

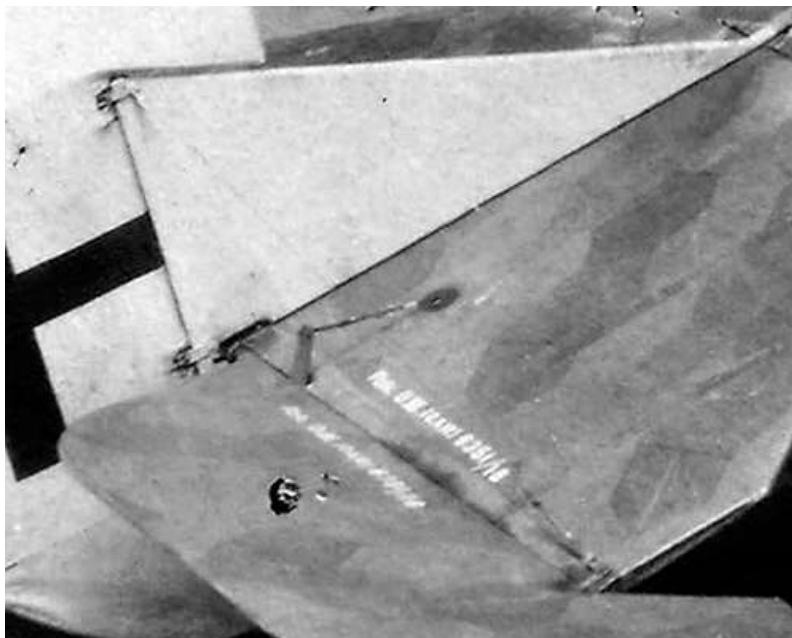

Upper wing:

The upper wing had crossed bracing cables fitted horizontally, but only between the wing ribs in the central sections. The outboard four wing ribs were not cross braced. In addition 'tapes' were fitted to cross each other vertically between each pair of wing ribs. These tapes extended across the entire wing and were located between the front and rear spars and between the rear spar and the wing trailing edge.

Lower wing:

The lower wing had crossed bracing cables fitted horizontally, spanning each side of the wing. The most outboard wing ribs were not cross braced. Cross bracing was also fitted between the wing front and rear spars below the cockpit floor. In addition 'tapes' were fitted to cross each other vertically across each pair of wing ribs. These tapes extended across both wings, except for the centre section under the cockpit floor and were located between the front and rear spars and between the rear spar and the wing trailing edge.

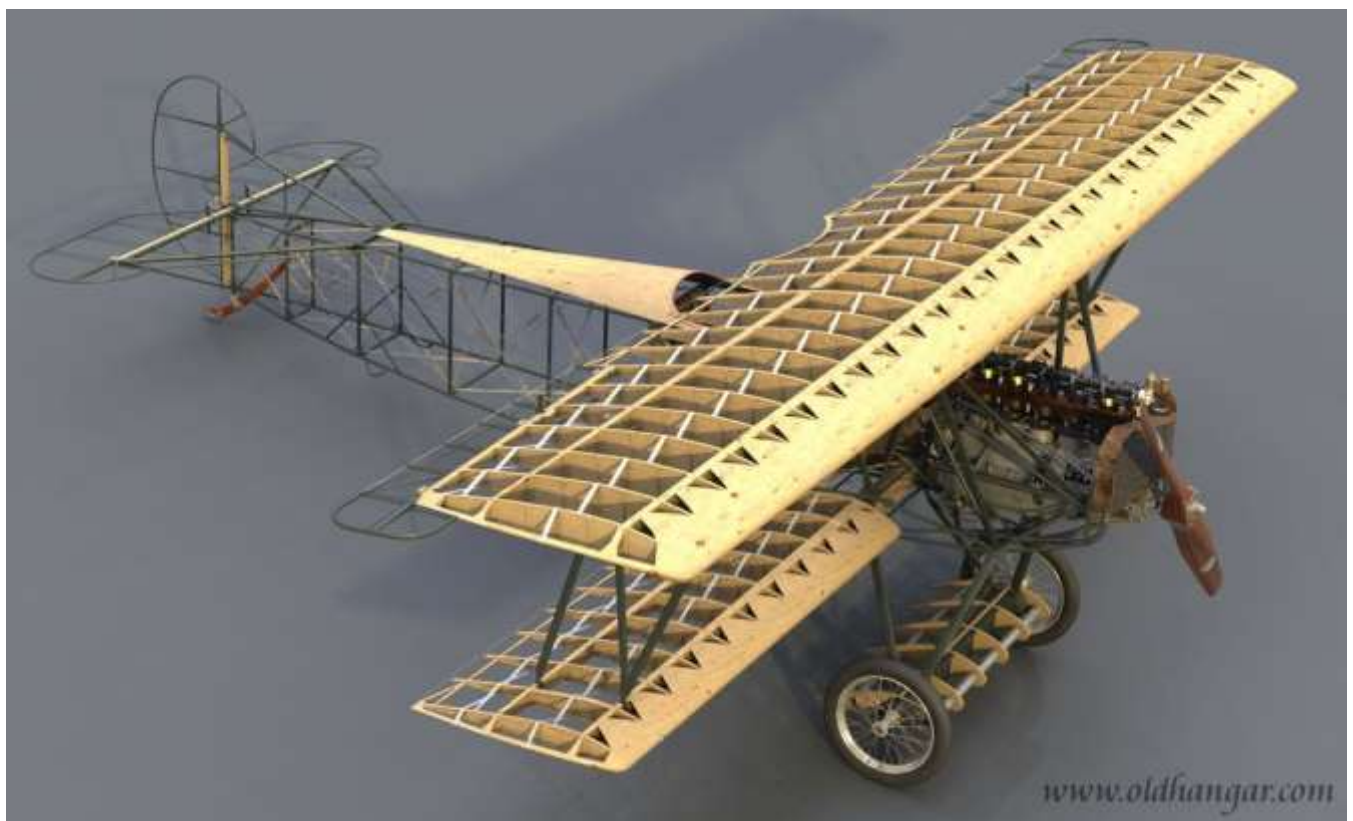

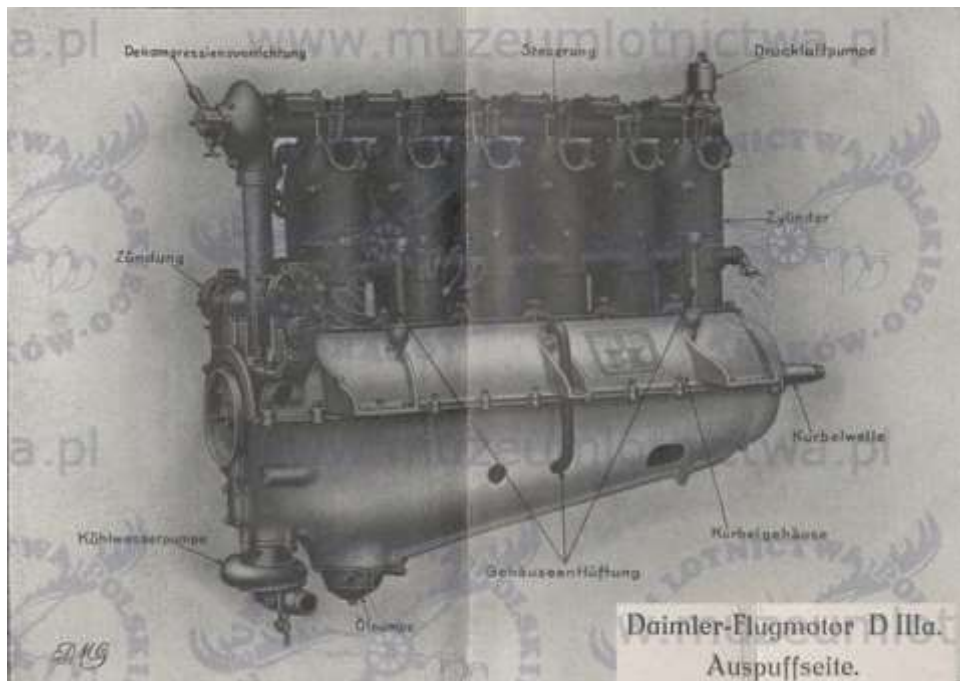

The engine can be built using either the engine supplied with the 'Wingnut Wings' kit or using parts from that engine with 3D printed parts from 'Shapeways'. This build log describes the engine build using the 3D printed components from 'Shapeways'. Refer to the associated Fokker D.VII build log for the kit supplied engine build.

NOTE 1: *The following steps detail the building of the engine prior to it being installed into the fuselage.*

NOTE 2: *This engine build is the one which will be **fitted to this model** build.*

NOTE 3: *The 3D printed parts do not have location stubs or holes, unlike the kit supplied parts. These parts need to be carefully aligned with each other before being fixed in position.*

NOTE 4: *The 3D components are printed using a fine acrylic material and therefore are not affected by standard styrene cements. It is recommended that the 3D printed components are secured using CA adhesive.*

NOTE 5: *Some of the "Wingnut Wings" donor engine parts will need to be modified to fit the 3D printed parts, therefore the engine needs to be built in the correct sequence.*

The following aftermarket parts will be used to replace kit items or to enhance the engine detail.

- 'Taurus Models' engine intake manifold lock rings (3211),
- 'Taurus Models' engine complete timing gear (3209) - conical valve springs only,
- 'Taurus Models' engine fuel priming cups (3219),
- 'Shapeways' 3D printed 1/32 Mercedes D.III Oil Pump,
- 'Shapeways' 3D printed Mercedes D.IIIa Cylinders (hollow),
- 'Shapeways' 3D printed Mercedes D.IIIa Crankcase,
- 'Shapeways' 3D printed 1/32 German Aircraft Magnetos,
- 'Shapeways' 3D printed 1/32 Mercedes Cylinder clamps,
- 'Shapeways' 3D printed 1/32 gun synchro mechanism.

The following modifications will be applied during the basic engine build:

- Ignition lead support rail
- Oil reservoir sight glass
- Spark plugs
- Ignition leads
- Additional pipes and coolant drain tap.
- Engine mounted controls.
- Propeller shaft.

Preparation and modifications:

1. Using a soft tooth brush or similar, wash the 3D parts in warm, soapy water then allow the parts to thoroughly dry.
2. The 3D engine sump and cylinder block are finely detailed, but the kit supplied propeller shaft does not fit into the 3D parts, due to the mounting bore being too small. Also there is no way for the flanges on the propeller shaft to fit into the 3D sump.
3. To resolve this problem the kit supplied propeller shaft was discarded in favour of a shaft cut from 'Albion Alloys' 1.6 mm diameter tube (MBT16). The tube was cut long enough to be secure in the engine block and with the same amount protruding from the block as the kit supplied engine.

NOTE 1: *The kit supplied engine has three parts, the sump, engine block and front cover. However the 3D printed engine block has the front cover as part of the engine block and therefore only has two parts.*

NOTE 2: *In the following step the propeller shaft is fixed in position as the fitted propeller is not intended to be rotated.*

4. The aftermarket 'Proper Plane' propeller to be used has a shaft hole drilled through the propeller boss. The hole is slightly larger than the 1.6 tube used for the propeller shaft. To increase its diameter to fit the propeller, a cut 5 mm length of 'Albion Alloys' 1.8 mm diameter tube (MBT18) was slid onto the exposed shaft tube and secured in position with CA adhesive. 'Tamiya' masking tape was then wrapped around that tube to increase its size to fit the hole in the propeller boss.
5. Position the 3D engine block onto the sump and once correctly aligned, secure in position using CA adhesive.

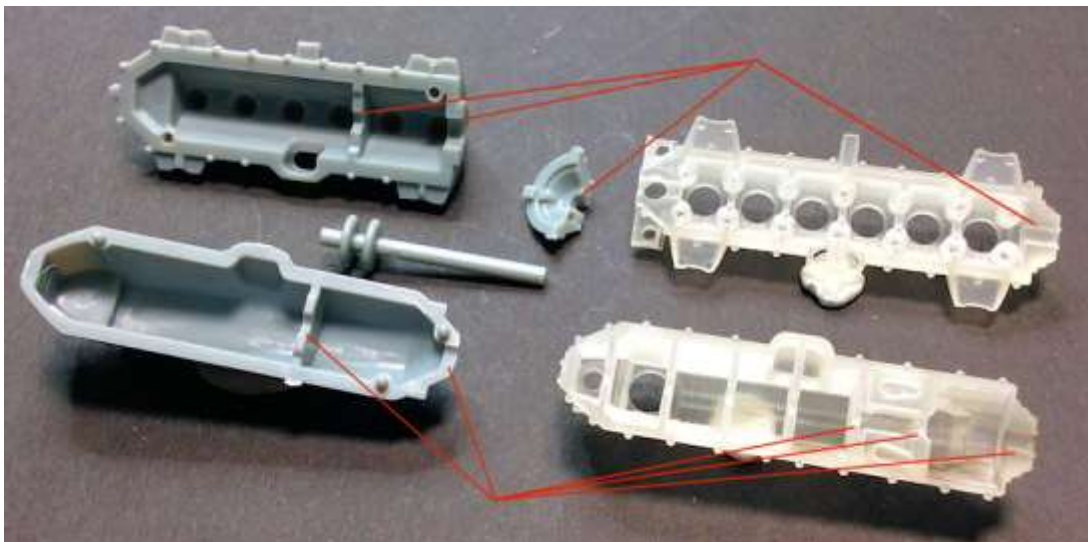



6. The 3D oil pump is printed on a solid cylinder of acrylic and needs to be removed before it can be attached to the engine sump.

To remove the oil pump from the solid cylinder I used a fine blade modellers saw and cut from the edges of the pump flange at an angle into the cylinder. This was done around the pump flange until the oil pump separated. Then with a finger, hold the oil pump down onto fine sand paper then lightly drag the pump across the sand paper ('finger drag') to gradually remove the acrylic from the rear of the pump.

I cut a disc of 0.2 mm diameter plastic card, large enough to cover the hole in the engine sump then secured it in position over the hole and secured it using CA adhesive. The oil pump was then attached to the disc using CA adhesive.



7. The six individual 3D cylinders are printed in a strip and attached only at the support material base. Using a fine blade modellers saw and the cylinder base flange as a guide, carefully saw through the four sides of the support material until the cylinder separates. 'Finger drag' the base flange of each cylinder over fine sand paper to remove residual acrylic.



8. Airbrush each cylinder and the engine block assembly using 'AK Interactive' Primer and micro-filler (Grey-758).

NOTE: Due to the nature of the material used and the current limitations in 3D printing, the painted surfaces may appear more matt than desired. If this is the case airbrush several light coats to achieve the desired finish.

9. Airbrush each cylinder with 'Tamiya' semi-gloss black (X18) and the engine block assembly with 'Alclad' gloss black base (ALC-305).

10. Airbrush the engine block assembly using 'Alclad' Duraluminium (ALC-102).

NOTE: Each of the 3D cylinders have location holes for spark plugs, fuel primers, ignition lead support tubes, intake manifold, valve springs and the exhaust pipes. Before attaching the cylinders to the engine block, it's best to prepare these location holes for when these aftermarket and engine donor parts are fitted.

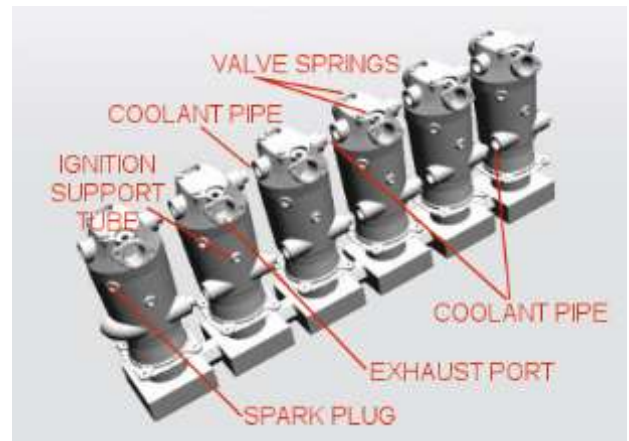
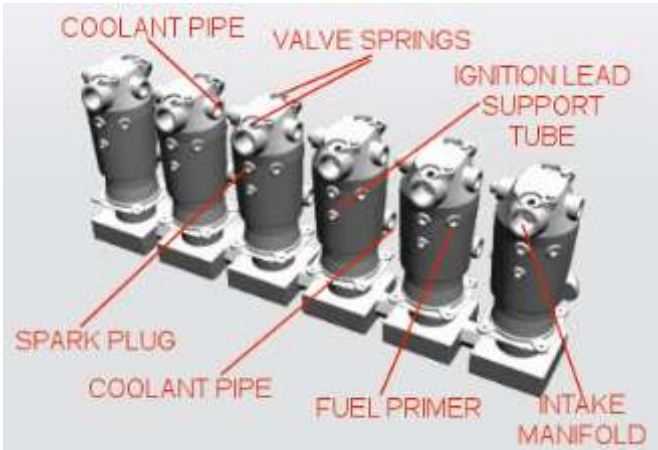

11. Coolant pipes: Located between the cylinder tops and at the lower right side of each of the cylinders. To ensure a good fit, twist a 1.0 mm diameter drill into the location holes to clear any primer and paint.
12. Spark plugs: Located top centre, left side of each cylinder - top angled to rear of right side of each cylinder. Drill out the 12 holes using a 0.9 mm diameter drill.
13. Ignition lead support tube: Located vertically central on both sides of each cylinder. Using a 0.5 mm diameter drill bit, drill out the location holes, *but only into the front and rear cylinders*. The four middle cylinders do not need to be drilled. *The cylinder at the rear has the curved coolant pipe attachment.*
14. Fuel primers: Located top angled to rear of left side of each cylinder.
15. Exhaust ports: Located top centre, right side of each cylinder. Ensure the donor exhaust is a good fit. Clear the holes as required.

16. Spark plugs:

The kit does not have spark plugs to fit to the six cylinders (two per cylinder), however the cylinders do have a location holes for the spark plugs. To represent the spark plugs and to allow 'PlusModel' 0.2 mm diameter wire to be attached as the ignition lead, I chose to make the spark plugs from brass micro-tube.

Cut a short length of 'Albion Alloys' 0.8 mm diameter tube (MBT2M), which has a 0.4 mm bore.

Cut a short length of 'Albion Alloys' 0.4 mm diameter tube (MBT04).

Insert the cut tube into the installed 0.8 mm leaving approximately 1.5 mm exposed.

Slide onto the 0.4 mm tube a 0.79 mm (0.31") Aluminium nut (1281-A) from 'RB Motion', so that it rests against the 0.8 mm tube

Secure the tube and nut in position using thin CA adhesive.

Repeat this procedure to create the required twelve spark plugs, which will be fitted later in the engine build.



17. Intake manifold lock rings:

To enhance the engine detail I replaced the engines pre-molded locking rings for the fuel inlet manifold with the 'Taurus Models' engine intake manifold lock rings (3211).

NOTE: *There are locking rings fitted to attach the intake manifold to each cylinder and two fitted to the carburetor body at the manifold outlets. To fit these two lock rings requires the intake manifold pipe at each side of the carburetor to be cut away. Therefore these two lock rings will not be replaced with 'Taurus' locking rings.*

On the inlet manifold (E4) cut off the locating stub on the two end pipes and sand flat.

Cut six locking rings away from the 'Taurus' set.

Fill then sand the holes for the inlet manifold on the 3D printed cylinders as they are not required.

Carefully cut away the stub at the rear of the locking rings, as this can't be used to locate the rings in the cylinder head, as the 3D holes too small and the side walls are too thin to drill out the holes to the required size.

The cut side of the locking ring needs to be flat so it can sit correctly against the cylinder. Therefore hold the lip of each locking ring with tweezers and carefully and lightly drag the locking ring in one direction, over fine sanding paper, so only the actual lock ring is left.



18. Ignition lead support rail:

A magneto was located on each side at the rear of the engine. These were driven by the engine through a split drive shaft. Attached to each magneto were six ignition leads, which were routed through support tube attached to each side of the cylinder block. Each cylinder ignition lead exited the support tube through an aperture and was then attached to the cylinder spark plug (two per cylinder). The pre-molded support tubes supplied in the kit seem under sized, so they will be replaced with micro-tube.

Temporarily connect the six cylinders together.

Cut two lengths of 'Albion Alloys' 0.8 mm diameter micro-tube (MBT08) to slightly shorter than the cylinder bank..

Using a pencil, mark the cut tubes at the location of the two attachment holes pre-drilled into the front and rear cylinders.

Using a straight scalpel blade, lightly score the tubes at the pencil marks then use the point to twist into the scores to penetrate that side of the tube.

Use a 0.4 mm diameter drill to open out the hole through that side of the tube only.

Cut short lengths of 'Albion Alloys' 0.4 mm diameter micro-tube (MBT04).

Secure the 0.4 mm tubes into the tube holes using CA adhesive.



19. Magnetos:

Each cylinder spark plug (two per cylinder - one each side) was supplied with electrical power from the magnetos (one per side). The six ignition leads from each magneto were routed through the support rail, fitted to the cylinders on that side. Each ignition lead exited from the support rail through a hole underneath the rail and close to the cylinder to which it was connected.

The replacement 3D printed magnetos are created in for separate parts, which need to be assembled.

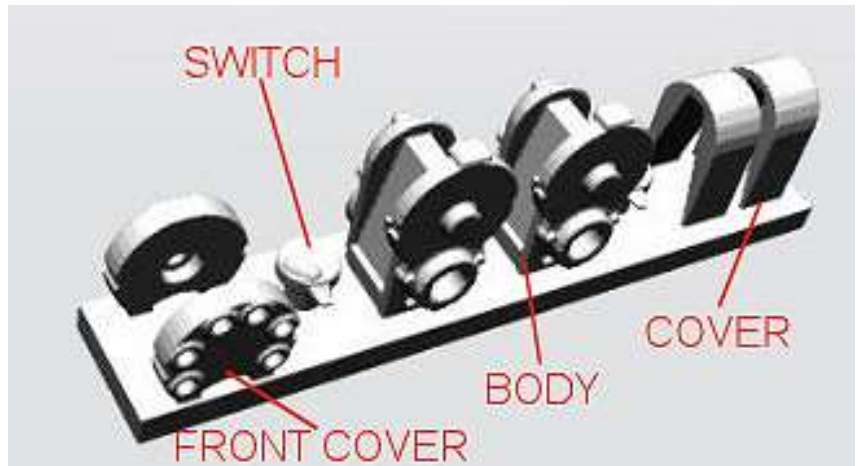

Using a shielded razor blade, carefully separate the parts for the two magnetos.

Locate the front cover onto the body and secure using CA adhesive.

Locate the cover over the body and secure using CA adhesive.

Locate the switch into the front of the body with the switch pointer positioned as shown in the above photograph. Secure using CA adhesive.



20. Magneto drive assembly:

The donor magneto drive assembly (E26) is molded to include the base mounting, which on the 'Wingnut Wings' engine would fit on the step at the rear of the engine and would have the two magnetos (E19, E20) attached at the sides. However the 3D printed engine block has the base mounting included. Therefore the drive assembly (E26) needs to be modified to fit the 3D engine.

Cut away the mounting base of the drive assembly (E26) to leave just the block at the bottom of the drive shaft.

Cut away the two location stems for the magnetos.

At the centres where the two location stems were, drill a 0.6 mm diameter hole through the block, then open up the hole with a 1.1 mm diameter drill.



Cut a length of 1.0 mm diameter brass rod and pass it through the hole in the block.

Dry fit the two magneto assemblies (hole in the rear face) onto the brass rod (one each side).

Position the assembly onto the step at the rear of the engine and the camshaft onto the top of the cylinders.

NOTE: *In the following step, if required, adjust the height of the magneto drive assembly (E26) to correctly align it. To increase height, pack the base of the magneto drive with thin plastic card or to reduce height, file or sand away the mating surface on the step at the rear of the engine.*

Check that the assembly sits on the step with the camshaft stub engaging the hole in the forward face of the decompression valve and the two magnetos positioned to the outer edge of the mounting step on the engine.

21. Additional pipes and drain tap:

Although the kit supplied engine is well detailed, there is still room to improve its appearance by adding various items not supplied in the kit.

- A. Crankcase oil breather pipe - fitted centrally on the right side of the crankcase, between the two oil fillers pipes (E17, E18). This pipe connected to the sump on that side.
- B. Pipe from the fuel manifold housing - to the sump mounted water pump.
- C. Two pipes between the left side of the air pump mounting - and the left side of the crank case.
- D. Coolant drain tap - located at the forward end of the coolant supply pipe at the lower right side of the cylinders. This was used for draining coolant from the cylinder jackets.

A. Crankcase oil breather pipe: **(to be fitted later in the engine build)**.



B. Pipe from the fuel manifold housing to the sump mounted water pump: **(to be fitted later in the engine build)**.

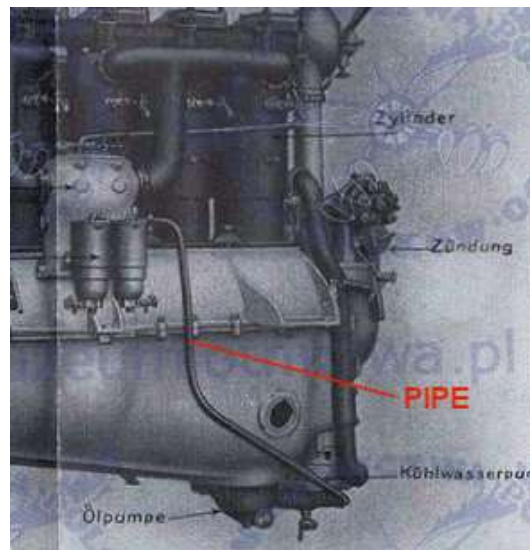

C. Two pipes between the left side of the air pump mounting case: **(to be fitted later in the engine build)**.



D. Coolant drain tap: (*to be fitted later in the engine build*).

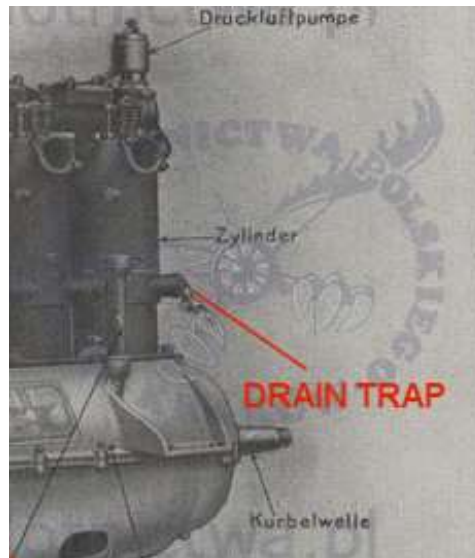

22. Fuel priming cups:

Fuel priming cups were commonly fitted to inline engines to allow fuel priming of the cylinders before an engine was started. Sometimes a primer was installed into each end of the fuel inlet manifold, as shown in the following photograph.



However fuel primers were often fitted to each cylinder in-
stead. These were adja-
plug (see below).

cent and to the rear of the spark

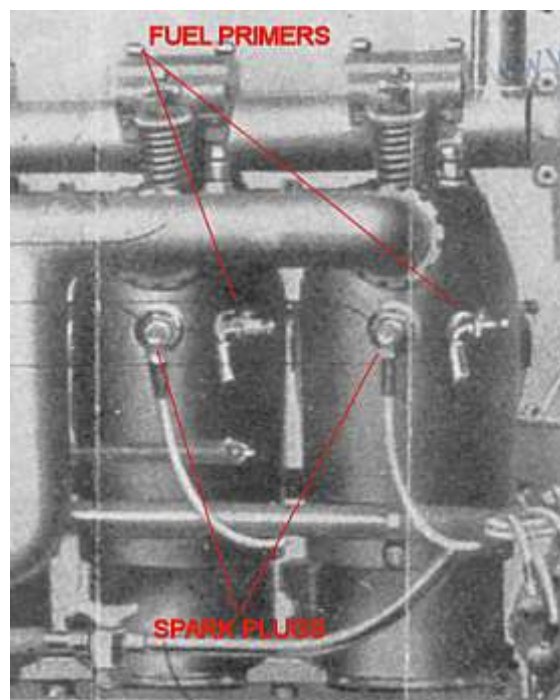

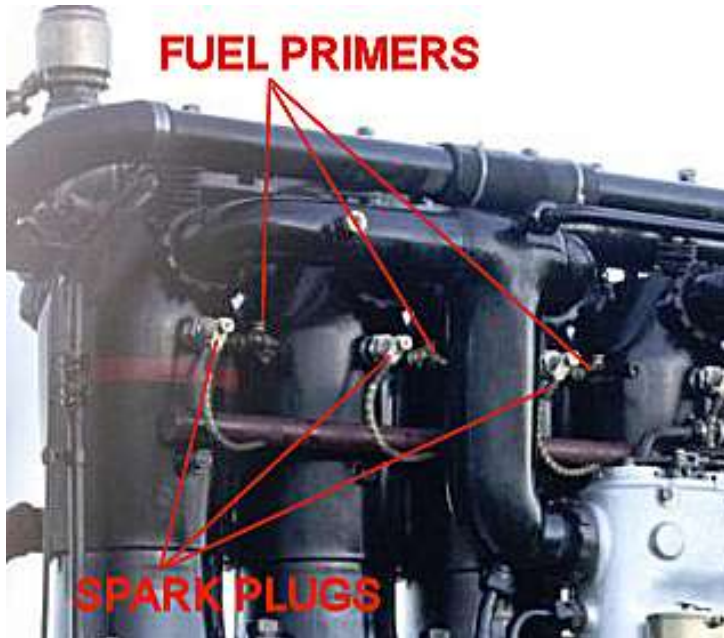

If cylinder mounting is desired, the 3D printed cylinders have a 'seating' location for a fuel primer on the left side of each cylinder to the rear of the spark plugs. The 'Wingnut Wings' kit does supply fuel primers, so aftermarket parts will be used and will be ***fitted later in the engine build.***

23. Engine sump apertures and oil reservoir sight glass:

The sump of the engine was essentially a 'dry' sump, as the oil reservoir was in a separate and sealed compartment at the rear and lowest part of the sump. The oil was drawn from this reservoir by the oil pump (located at the rear of the engine) and distributed through the engine. The oil drained into the reservoir to be recirculated. The forward part of the engine sump was open, as could be seen through the open apertures and the front of the sump. An oil contents sight glass was located on the side of the oil reservoir at the rear of the sump.

The 3D printed engine sump already has open apertures in the sump. The sump also has an oil sight glass aperture in the lower rear, left side of the sump.

The sight glass itself can be created using PVA adhesive for a clear 'glass' or by mixing 'Tamiya' Clear Yellow (X24) with 'Tamiya' Clear X22). Either dropped into the aperture will dry clear to represent a sight glass. This is best done ***later in the engine build.***

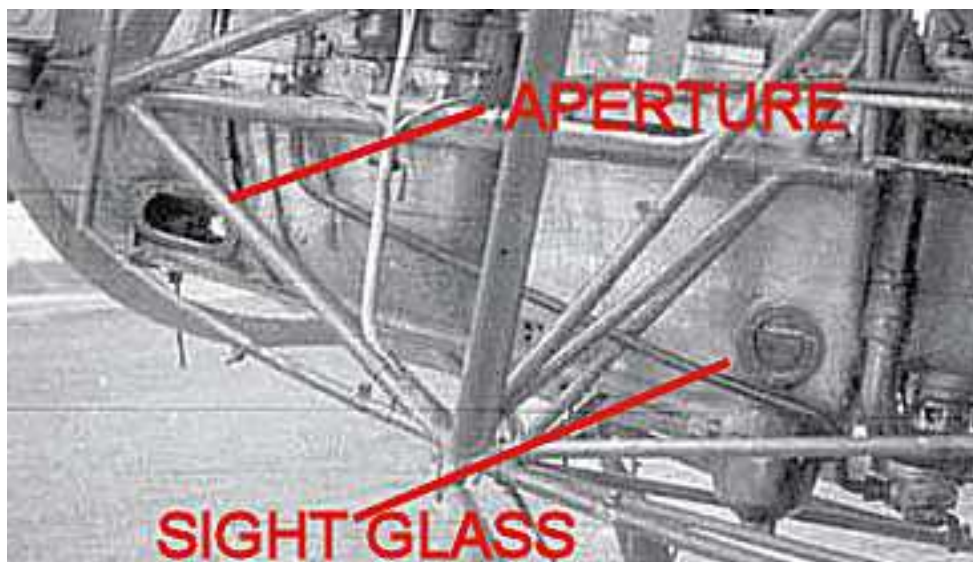

Engine build:

NOTE: Donor engine pipe (E21) is not being used and will be replaced with lead wire during the engine build.

24. Using 'AK Interactive' primer and micro-filler (Grey-758), prime the following engine parts:

Assembled 3D printed magnetos

3D printed cylinder clamps

Brass tube created ignition lead support tubes

Modified 'Taurus Models' locking rings

'Taurus Models' valve springs from Timing Gear set (3209)

'Wingnut Wings' engine - donor parts:

Rocker box (E27)

Air pump (E29)

Intake manifold (E4)

Carburetor (E22)

Magneto drive (E26)

Coolant pipe (E30)

Oil filler pipes (EE17, E18)

Water pump (E32)

Speed controller (E12)

Generator (E43)

Generator drive case (E36).

25. Paint the following parts:

Assembled 3D printed magnetos:

Body cover- 'Mr. Colour' Stainless Steel (213),

Switch, front cover, body - 'Tamiya' Rubber Black (XF85)

Switch body - 'Mr. Colour' Copper (215) mix with Brass (219)

3D printed cylinder clamps

Water pump (E32) - 'Alclad' Steel (ALC-112)

'Taurus Models' valve springs from Timing Gear set (3209) Generator drive case (E36)

Brass tube created ignition lead support tubes - 'Tamiya' Hull Red (XF9)

Air pump (E29) - 'Mr. Colour' Brass (219)

Magneto drive (E26) - Mr. Colour' Stainless Steel (213)

Carburetor (E22) - 'Mr. Colour' Stainless Steel (213), Brass (219)

Coolant pipe (E30) - 'Tamiya' Rubber Black (XF85)

Oil filler pipes (EE17, E18) - 'Tamiya' Rubber Black (XF85), 'Mr. Colour' Brass (219)

Speed controller (E12) - 'Mr. Colour' Stainless Steel (213), 'Tamiya' Hull Red (XF9)

Generator (E43) - 'Mr. Colour' Stainless Steel (213), 'Tamiya' Dark Green (XF61)

Rocker box (E27)

Modified 'Taurus Models' locking rings - 'Alclad' Exhaust Manifold (ALC-123).

Intake manifold (E4)

26. Clean away any primer or paint from the underside of each cylinders base and also across the cylinders mounting face on the engine block.

NOTE: *When attaching the cylinders to the engine block, make sure that:*

1. *You identify the rear cylinder as it is different from the rest in that it has the coolant pipe connection on its rear face.*
 2. *The cylinder are correctly orientated - exhaust ports to the right and the filled in intake manifold ports to the left.*
 3. *The front and rear cylinders are those that have the pre-drilled holes to fit the created ignition lead support tubes.*
27. Apply CA adhesive onto the engine block at the front cylinder mounting area, then position the front cylinder onto the block.
28. Apply CA adhesive into the two location holes (right side) in the front cylinder where the two cooling tubes of the next cylinder connect.
29. Apply CA adhesive onto the engine block at the next cylinder mounting area, then position the next cylinder onto the block and into the pipe locating holes of the front cylinder.
30. Repeat this procedure to fit the next three cylinders, making sure all of the cylinders stay aligned on the engine block.
31. Lastly position and secure the rear cylinder.



32. Cement the air pump (E29) onto the its stub at the front of the camshaft (E27).

NOTE: *The 3D printed cylinders have two small stubs on the top of each cylinder, which are the extensions for the rocker box cover. Although the kit supplied camshaft (E27) does sit on these stubs, the contact area is too small to provide good adhesion for fitting. The camshaft has molded 'cross bars at these points which will provide more contact area.*

33. To provide more contact area, carefully file or sand away the two small stubs on the top of each cylinder.

34. Locate each created spark plug into its pre-drilled cylinder hole and secure using CA adhesive.
35. Locate the created ignition lead support tubes into their pre-drilled location holes in the front and rear cylinders. Secure using CA adhesive.
36. Spread CA adhesive across each cylinder head where the 3D printed camshaft studs were located. Carefully position the camshaft onto the cylinders, making sure each of the valve spring rocker arms (tappets) are over the spring locations.
37. Coolant drain tap:
To replicate the coolant drain tap I used cut away the handle from a Fokker D.VII cockpit oil pump (from the 'spares' box).
A hole of 0.3 mm diameter was drilled vertically through the stub on the forward end of the lower, right hand cylinder coolant supply pipe. A cut length of 'Albion Alloys' 0.2 mm diameter Nickel-Silver rod (NST02) was inserted into the hole to protrude from the bottom of the stub. This and the handle were then secured in position using CA adhesive. The handle was then painted with 'Mr. Colour' Brass (219).



38. Cylinder base bridging clamps:
NOTE: *The two forward bolts of the front cylinder and the two rear bolts of the back cylinder did not have bridging clamps fitted.*
'Finger drag' the 3D printed cylinder clamps (on the printed block) across fine sand paper to remove the backing block, leaving a very thin layer to retain the clamps. Separate each clamp using a shielded razor blade. Position a clamp between the corners of adjacent cylinder bases and secure in position using CA adhesive.





39. Additional pipes:

In the left side of the base for the air pump, drill two holes of 0.4 mm diameter.

On the front, top of the crank case, drill two holes of 0.4 mm diameter.

Cut two lengths of 0.375 mm diameter copper wire.

Bend the copper wire to shape to fit in the drilled holes.

Secure the two pipes in the holes using CA adhesive.

Brush prime pipes grey.



40. Crankcase oil breather pipe:

Between the centre reinforcing webs on the right side of the crank case, drill a 0.8 mm diameter hole vertically through the web and close to the engine sump.

Drill a 0.8 mm through the engine sump, vertically below the drilled web.

Cut a length of 'PlusModel' 0.7 mm diameter lead wire to form the pipe.

Pass the lead wire through the drilled hole in the web then loop the top end into the hole in the 3D printed engine block.

Insert the bottom end of the lead wire into the drilled hole in the engine sump.

Shape the pipe then secure in position using CA adhesive.



41. Conical valve springs:

The actual valve springs were conical and angled slightly outboard. The springs supplied in the 'Taurus' complete timing gear set (3209) are more accurate, so were used. The rest of the 'Taurus' set was not used.



NOTE: For the sake of accuracy, refer to the 'Taurus' instructions to make sure you have 'OPEN' and 'CLOSED' valve springs in their correct locations.

Cut away the 'Taurus' valve springs from the mounting base.

On each valve spring, trim off the extended valve stem at the top (widest diameter) of the valve spring.

NOTE: *The conical valves springs are not fitted vertically, but angle outboard at the top.*

Offer up each valve spring in turn between the valve seat and its rocker arm. Cut the bottom of the spring until it fits between the cylinder head and its rocker arm.

Secure each valve spring in its position using CA adhesive.

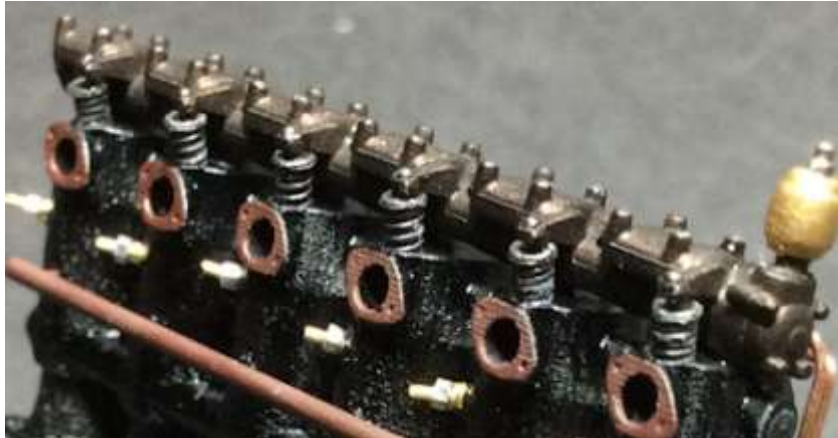

42. Magneto drive assembly:

NOTE: *The magneto drive assembly should have test dry fitted at step 20.*

Position the drive assembly (E26) onto the location peg on the rear end of the camshaft and onto the mounting step at the rear of the engine. Make sure the shaft is vertical and central on the step. Secure in position using CA adhesive.

Secure the decompression valve onto its location on the top, rear of the drive shaft assembly.

Slide the cut 1.0 mm diameter brass rod through the pre-drilled hole in the base of the shaft assembly and once central, secure with CA adhesive.

Locate the two magnetos onto the brass rod and align their bases to the outer edge of the mounting step.

Secure the magnetos in position using CA adhesive.



43. Ignition Leads:

Each cylinder spark plug (two per cylinder - one each side) was supplied with electrical power from the magnetos (one per side). The six ignition leads from each magneto were routed through the support tube, fitted to the cylinders on that side. Each ignition lead exited from the support rail through a hole underneath the rail and close to the cylinder to which it was connected.



Cut 24 lengths of 'PlusModel' 0.3 mm diameter lead wire (or similar).

Insert 5 wires into the open end of the two ignition lead support tubes and secure with CA adhesive.

Add another wire to the above to increase the wire total to six.

Position each wire to a connection point on the magneto face and trim to length then secure with CA adhesive.

Secure a wire to the centre of each cylinder, under the ignition support tube using CA adhesive.

Loop each wire up and to the tip of its spark plug then secure to the spark plug using CA adhesive.

Brush paint the 'leads' with the colour of your choice - I use either dark yellow, red or black.

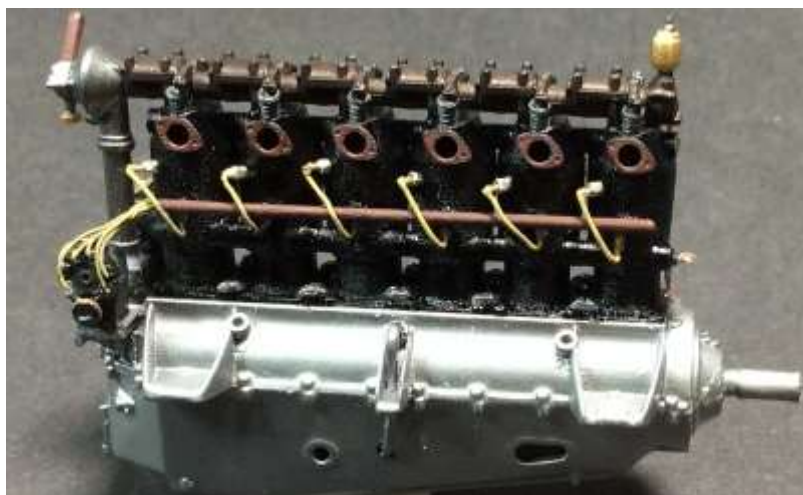

44. Intake manifold and lock rings:

NOTE: *The six 'Taurus' locking rings for the inlet pipes of the fuel intake manifold were prepared earlier.*

Cut or file away the locating stub on the bottom of the fuel inlet manifold (E4) as it does not fit fully into the 3D printed engine block recess.

Cement the carburetor (E22) onto its location on the fuel intake manifold (E4).

Secure a locking ring onto the cylinder end of each fuel inlet pipe, using CA adhesive.

Locate the fuel inlet manifold onto its location base on the engine block with the fuel inlet pipe locking rings against the filled in inlet ports on the cylinders, then secure each of the mating faces with CA adhesive.

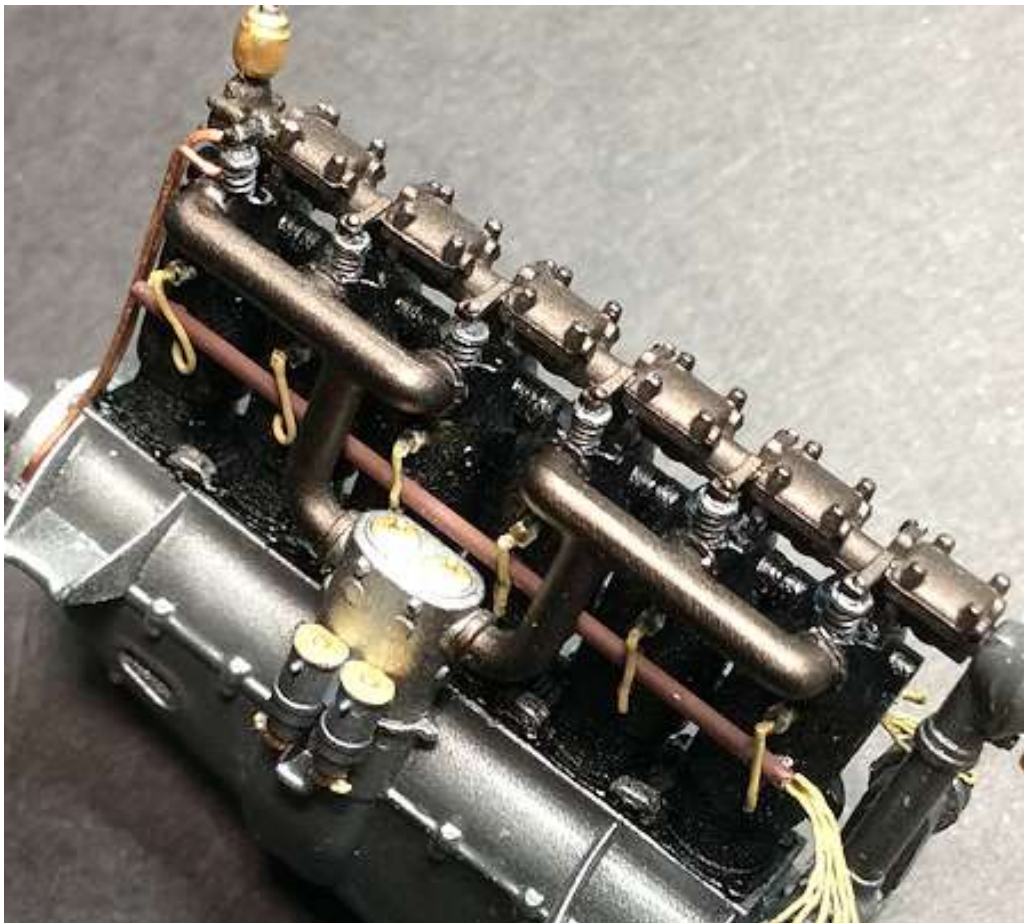

45. Water pump and coolant pipe:

Test locate the water pump (E32) onto its location at the bottom, rear of the engine sump and the coolant supply pipe (E30) between the pump and rear cylinder connection. Make sure the pump and pipe align and the pipe aligns to the cylinder connection.

Note the position of the water pump on the engine sump.

Position the water pump as before and secure using CA adhesive.

Position the coolant pipe between the pump and rear cylinder. Secure using CA adhesive.



46. Intake manifold pipe:

A pipe was fitted between the top of the fuel intake manifold and the back of the rear cylinder. The pipe was routed below the rear three spark plugs on the left side of the engine.

Using a length of 0.6 mm diameter 'PlusModel' lead wire, bend one end into a very short right angle. Secure this end into the hole at the top, back of the rear engine cylinder, using CA adhesive.

Bend the wire and pass the other end under the three rear spark plugs on the left side of the engine.

Bend the wire to conform around the rear cylinder.

Make sure the wire lays flat on top of the ignition lead support tube then bend the free end to touch the top centre of the fuel inlet manifold.

Secure the pipe to the top of the manifold using CA adhesive.



47. Generator and drive:

This particular engine was sometimes fitted with an engine driven generator on the rear, left side of the engine. The drive train was located in a cover at the rear of the engine.

NOTE: *The kit supplied generator (E43) has a small pre-molded recess on the underside, which fits over the forward flange of the left, rear web on the 'Wingnut Wings' engine block. However the same flange on the 3D printed engine crankcase does not allow the generator to sit against the engine block.*

File the existing recess on the underside of the kit supplied generator until the generator sits correctly on the curved edge of the engine block.

Secure the generator in position on the engine block, using CA adhesive.

Test fit the generator drive housing on the rear of the engine, making sure the generator shaft enters the hole in the housing.

If necessary, trim the length of the generator shaft until the drive housing fits fully against it and the rear of the engine.

Secure the generator drive housing in position, using CA adhesive.



48. Oil filler pipes:

Test fit the two oil filler pipes (E17, E18) in their location in the right side of the engine block.

If necessary, open up the location holes using a 0.8 mm diameter drill.

Secure the two oil filler pipes into their location holes using CA adhesive.



49. Oil sight glass:

To represent the oil sight glass in the side of the engine sump, mix 'Tamiya' Clear (X22) with Clear Orange (X26) and brush this into the aperture to fill it to the surface. Leave the engine on its side until the solution has dried.



50. Fuel primers:

The 'Wingnut Wings' kit does not supply the fuel primers fitted to the left side rear of each of the engines cylinders. The 3D printed engine cylinders do have a location for these primers, so the 'Taurus Models' fuel primers will be used.

From the 'Taurus Models' engine fuel priming cups (3219), cut away six levers (part 2).

NOTE: *During the next step, make sure you position the levers in the fuel primers in the 'closed' position.*

Using CA adhesive, attach each lever to a fuel primer (part 1).

Brush paint the valve body 'Mr. Colour' Brass (219) and the lever handles 'Tamiya' Hull Red (XF9).

Cement a fuel primer onto its 'seating' on each of the cylinders. Make sure the handle is orientated to the 'CLOSED' position (refer to the 'Taurus Models' instruction chit).



51. Additional pipes:

On the actual engine there were additional pipes, some of which are not covered by the 'Wingnut Wings' kit. To enhance the model these pipes need to be represented.

1. A pipe was connected to the rearward side of the fuel manifold and was routed down and across to connect to the water pump.

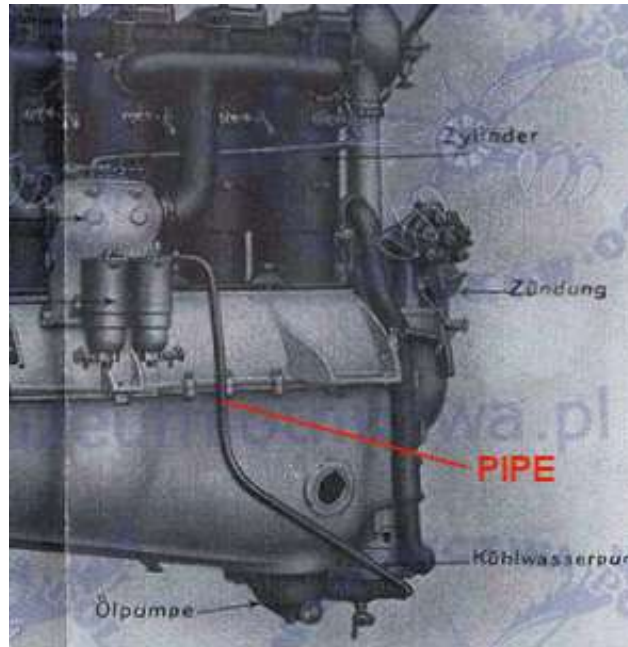

Drill a 0.4 mm diameter hole into the pipe location on the rear face of the fuel manifold and also into the left side of the water pump.

Cut and bend a length of 0.375 mm diameter copper wire so the ends fit into the drilled holes and the pipe routes as shown in the illustration.

Secure the pipe in position using CA adhesive.

Brush the pipe with grey primer.



2. A fuel feed pipe was connected to each of the carburetors and was routed rearwards to connect the base of the fuel tank. ***These two pipes can only be fitted once the engine has been installed to the forward fuselage, including the cockpit assembly.***
3. A coolant was connected to an outlet on each side of the bottom of the radiator. These two pipes were routed rearwards under the engine and combined to a single pipe, which was connected to the engine driven water pump. This pipe supplied the cooled coolant from the radiator back to the water pump to be recirculated through the engine. ***This pipe (B19) is supplied in the 'Wingnut Wings' kit, but again, can only be fitted once the engine has been installed to the forward fuselage including the cockpit assembly.***

52. Decals:

NOTE: *The red stripe decals (77, 78) supplied with the kit denote engines with over compressed cylinder/piston designs. These engines carried the annotation ü (meaning 'über' - over compressed). This particular model has the Daimler-Mercedes 180 hp D.IIIa engine and without the ü annotation is assumed to be of standard design and therefore does not require the red stripe decals.*

Following the kit instructions, apply decals 74, 74a, 82, 83, 84, 85.

Apply solvent, such as 'MicroSol', to conform the decal. Leave the solution to fully dry.

Seal the decals by airbrushing with 'Alclad' Semi-Matt lacquer (ALC-312).



53. Gun synchronization mechanism:

The 'Wingnut Wings' kit does not supply the synchronization mechanism for the two machine guns, so the 3D printed set by Bob Monroe ('Flugzeugwerke') from 'Shapeways' will be used. The mechanism was located on the rear of the decompression valve, which was on top of the magneto drive assembly at the rear of the engine. The mechanism had three connections - two for the machine gun synchronization cables and between them, the drive to the cockpit for the tachometer instrument.

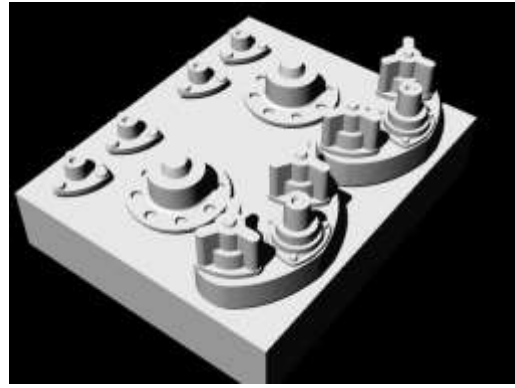

NOTE: *Although very detailed, the 3D printed parts are extremely small and great care is required to separate them from the substantial base block. I found it difficult to remove the two small plates without breaking them, so chose instead to replace them with discs of plastic card.*

First airbrush primer onto the set to enable it to be more easily seen.

Use a fine modelling saw to separate the two sets of parts from the base block.

Holding the main mechanism and then the circular drive housing (base block material down) with tweezers, carefully rub the parts back and forth across medium to fine sand paper. Regularly check the sanding is flat all around the part. Stop sanding when the edge of the part starts to break away.

Remove any remaining 'flash' from around the parts.

Carefully sand flat: The rear face of the decompression vale / The location stub of the shaft of the circular drive housing / The two location stubs on the two raised lugs of the main mechanism.

Position the circular drive housing onto the rear face of the decompression vale and secure in position using CA adhesive.

NOTE: *During the next step, refer to the previous illustrations to make sure you fit the main mechanism the correct way up.*

Position the main mechanism onto the shaft of the circular drive housing and secure it in position using CA adhesive.

Cut two discs of 1.5 mm diameter and then secure them onto the two raised lugs on the main mechanism.

Re-prime the parts using 'AK Interactive' primer and micro-filler (Grey-758).

Brush paint the parts with 'Mr. Colour' Stainless Steel (213).



54. Engine mounted controls:

The engine controls and instruments supplied as part of the kit consist only of operating levers or instruments etc. As the engine controls and cables are to be added, they will need to be scratch built.

The following items require adding between the engine and cockpit once the engine has been fitted into the fuselage with the cockpit:

Throttle control.

Spark advance control (ignition timing).

Hand throttle cables.

Tachometer drive cable to cockpit instrument.

Cockpit fuel selectors.

Magneto starter and ignition switch.

The following controls can be added to the engine before it is installed :

Throttle control.

Ignition control (spark advance)

Throttle control:

The pilot's primary throttle was lever operated and located at the left cockpit side frame. The lever was moved fore and aft on the throttle quadrant and varied the amount of fuel delivered to the engine twin carburetor. The base of the lever was attached to a control rod which was routed forwards to the left, rear of the engine, where it was attached to the bottom of a pivoting lever. The information about how this lever was mounted is difficult to find. However it seems the lever was located on the left side frame. A cross bar is not represented in the kit so will have to be made and added to the side frame. The top of this lever was connected by an angled control rod, to the dual carburetor operating cam. The dual carburetors were interconnected by a control linkage. As the throttle lever was moved the carburetor linkage altered the fuel flow in both carburetors.

General controls view

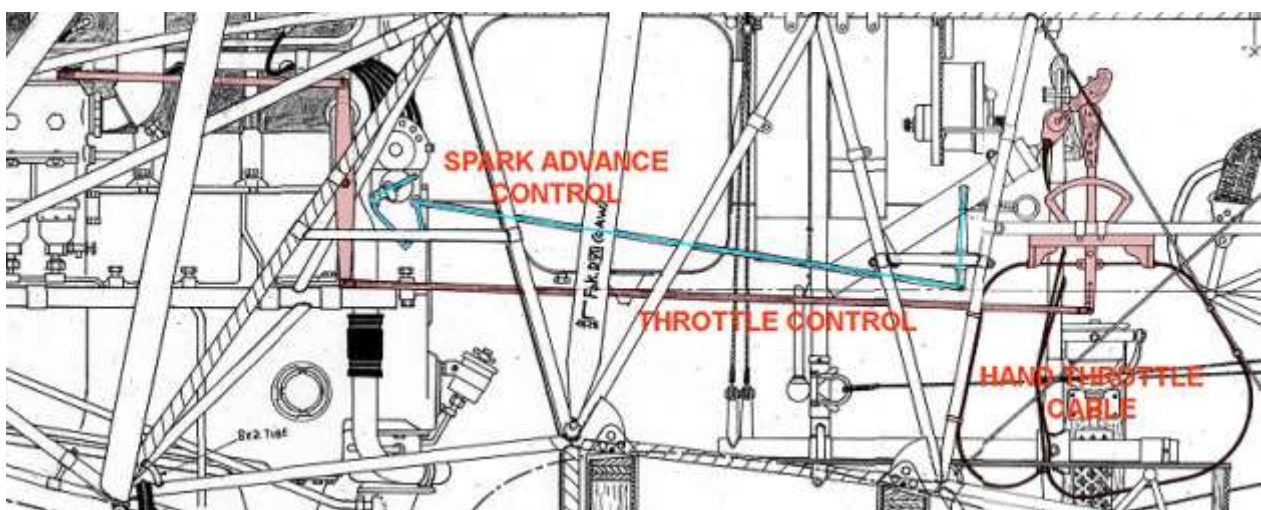

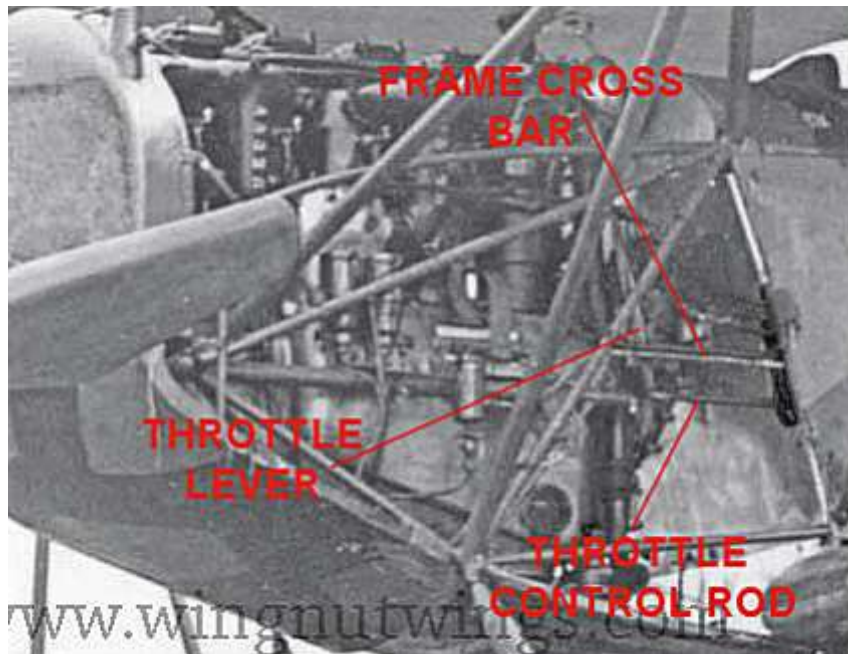

NOTE: Only the throttle control mounted on the engine can be created at this stage in the model build. The remainder of the throttle control run will be added once the engine is installed, later in the build.

To replicate the engine mounted throttle control pivot lever and linkage to the carburetors:

To ascertain where the lever should be mounted on the left side frame, assemble the fuselage frames B6, B10, B11, B14, B15 and B17.

Test fit the engine onto its frame mounts and using a pencil, mark the left side frame just below the generator shaft (see photo below).

Cut a length of 'Albion Alloys' 0.5 mm diameter brass tube and chamfer the ends until it fits within the side frame at the pencil mark.

Secure the tube in the left side frame using CA adhesive.

Repeat this procedure on the right side frame.

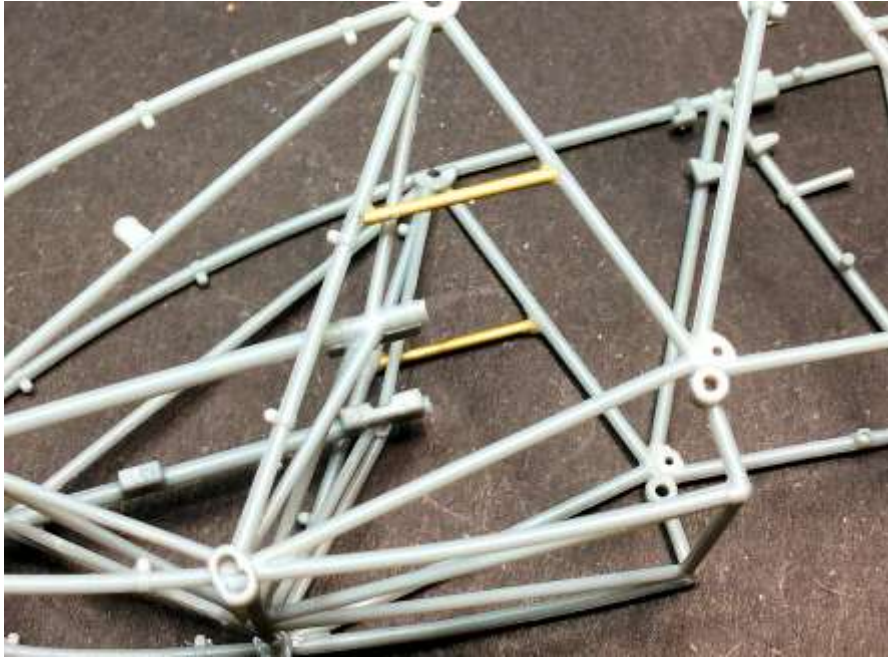

To create the lever I used cut a strip of 'spare' photo-etch then sanded the ends round. A hole of 0.2 mm diameter was drilled through each end and a hole c0.3 mm diameter through the centre.

To create the linkage at the twin carburettors:



The linkage pulley was from the photo-etch 'Eduard' Swordfish hinge and panel set (32204). The linkages were cut and modified from the 'RB Productions' British wire terminals set (RB-P32013) with the rod cut from 'Albion Alloys' 02. mm diameter Nickel-Silver rod (NSR02).



Ignition control (spark advance):

Controlling when the spark plugs 'fired' in the engines cylinders (ignition timing) was important as ignition timing affects many variables including engine longevity, fuel economy, and also engine power. The pilot was able to manually adjust spark plug ignition using the 'spark advance' lever, located at the left cockpit side frame, forward from the throttle lever. Like the throttle lever, it was moved in an arc to either advance or retard the ignition in the cylinders. The bottom of the lever was connected by a control rod to a spindle, located across the lower rear of the two magnetos. At both ends of the spindle were linkages that were connected to the operating levers on the front of each magneto. These linkages were fitted with spring tensioners, attached to the engine block. As the 'spark advance' lever was moved the magneto linkage altered the point at which the magnetos would 'fire' the spark plugs in the engine cylinders.



NOTE: Only the magneto controls that are mounted on the engine can be created at this stage in the model build. The remainder of the 'spark advance' control run will be added once the engine is installed, later in the build.

Cut a length of 'Albion Alloy's' 0.4 mm tube (NST04) and 0.2 mm diameter Nickel-Silver rod (NSR02).

Trim the 0.4 mm tube so that when it is positioned across the engine, behind both of the magnetos, the ends are level with the outer bottom edge of the magnetos.

Trim the 0.2 mm rod so it is 1.0 mm longer than the 0.4 mm tube.

Slide the 0.2 mm rod through the 0.4 mm tube so 0.5 mm protrudes from each end.

Secure the rod in the tube using CA adhesive.

Position the tube/rod assembly across the engine, behind the magnetos, so that the 0.2 mm rod ends are proud of the outer bottom edge of the magnetos.

Secure the tubes assembly using CA adhesive.

The linkages were cut and modified from the 'RB Productions' British wire terminals set (RB-P32013) with the rod cut from 'Albion Alloys' 02. mm diameter Nickel-Silver rod (NSR02).



Refer to the photo and secure the photo-etch parts to the rod and magnetos.

Coil 0.125 mm diameter wire around a 0.2 mm drill to form the return springs.

Cut the secure the springs to the magneto lever and reinforcing web on the engine, using CA adhesive.

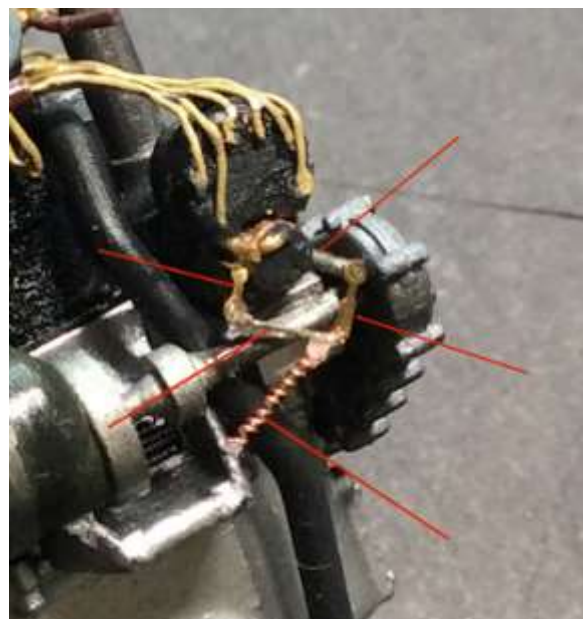

Mixture control (for information only)

On some engines the pilot also had a mixture control lever, located on the primary throttle quadrant at the left cockpit side frame. The lever was moved fore and aft on the throttle quadrant and varied the fuel/air mixture delivered to the engine. This allowed the pilot to reduce the amount of fuel being delivered at higher altitudes, due to less air being available.

NOTE: *However mixture control was normally an automatic function of the twin carburetor and although the throttle quadrant supplied in the 'Wingnut Wings' kit features this control lever, it will not be a feature of this model.*

PART 7 - PROPELLER

For this build I chose to replace the kit supplied propellers with wood laminated, hand made 'Heine' propeller from 'Proper Plane' (32-003), which is supplied with resin mounting plates. The propeller comes pre-varnished and has a smooth surface.

1. Drill out the mounting hole in the propeller and the **rear** resin mounting plate to a diameter that fits the propeller shaft on the engine.
2. Airbrush the propeller with several light coats of 'Tamiya' Clear Orange (X26), thinned with 'Tamiya' X20A thinners.
3. Airbrush a light coat of 'Tamiya' Hull Red (XF9), thinned with 'Tamiya' X20A thinners.
4. Using a very fine sander, carefully and lightly sand away the Hull Red colour to leave a trace of it on the propeller.
5. Polish the surfaces of the propeller.
6. Apply the kit supplied 'Heine' decals (87).
7. Seal the propeller using 'Alclad' Light Sheen lacquer (ALC-311).
8. If desired, lightly sponge brush weathering to the leading edges and tips of the propeller using 'Tamiya' Weathering Master Set B (Rust).

NOTE: *Be careful when working with resin as resin dust or particles are harmful if they are inhaled or ingested.*

9. Using a fine saw, carefully cut away the front and rear mounting plates from the molding block.
10. Clean up the back of each mounting plate by holding down the front face with a finger and 'drag' them lightly over the sanding surface.
11. Prime the mounting plates using Grey (AK-758).
12. Brush paint the mounting plates with 'Mr. Metal' Stainless Steel (213).
13. Once dry, buff the surfaces to a metallic finish.

NOTE: *When attaching the rear mounting plate to the propeller, make sure the drilled holes are aligned to allow the assembly to fit on the engine propeller shaft.*

14. Attach the mounting plates to the propeller hub using CA adhesive.
15. If desired, apply 'AK Interactive' Kerosene wash (AK 2039) to the mounting plates.



PART 8 - FUSELAGE (with engine, cockpit, weapons)

NOTE 1: Throughout this build, an airbrush is used for applying primer, paint and sealing coats, unless specified otherwise (e.g. Brush).

NOTE 2: Throughout this build, the primer used will be 'AK Interactive' primer and micro-filler (AK -758 Grey) and the paints used will be 'Tamiya' acrylics. Any different will be specified.

NOTE 3: Throughout this build the CA adhesive used is of the 'thin' variety, as opposed to the general thicker types.

Before any construction of the cockpit and fuselage can be started, quite severe modifications are required. This is because the kit construction requires the pilot's seat frame (A46) to be fitted to the side frames (B10, B11). However the 3D printed fuselage also has an in-built pilot's seat frame and obviously only one seat frame can be used. In addition the required joint between the kit side frames and the 3D printed fuselage is a potential weak area, as this joint needs to support both the front and rear of the fuselage. To allow fitting of one pilot's seat frame and to strengthen the fuselage joint, the 3D printed fuselage and the kit supplied cockpit side frames (B10, B11) need to be modified.

1. Using a sharp scalpel blade, carefully cut the kit side frames as indicated in red.
2. Using a fine bladed saw, carefully cut the 3D printed fuselage as indicated in red.
3. File or sand away the top and bottom kit side frames to remove any protrusions at the cut ends.

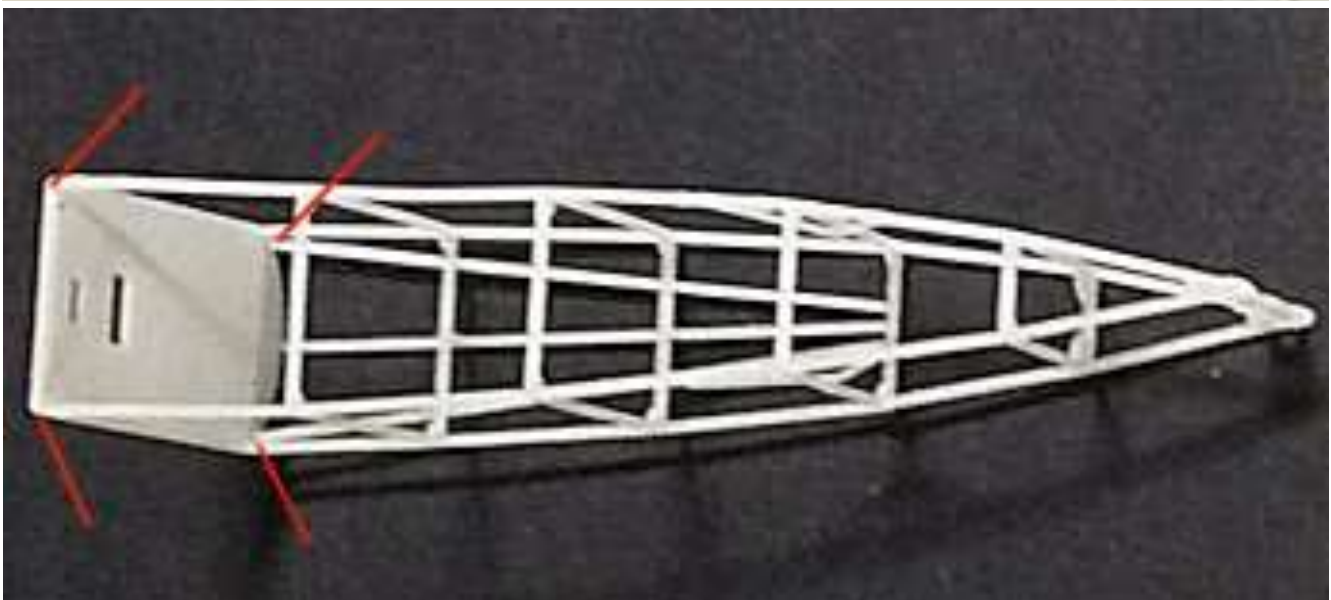

4. Cut away the corners of the frame tubes on the pilot's seat frame to allow a 1.2 mm diameter brass tube to sit in the corners.
 5. Lay a kit side frame against the cut ends of the 3D printed fuselage.
 6. Cut four 'Albion Alloys' 1.2 mm diameter brass tubes (MBT12) to span between uprights on the kit side frames and the 3D printed fuselage.
 7. Make sure the internal bore of the tubes are cleared of any metal burrs by twisting a 1.0 mm diameter drill through the cut ends.
 8. Slide the four cut tubes onto the kit side frames then onto the 3D printed fuselage.
 9. Test fit the pilot's seat frame (A26) into the joined fuselage and cut the corner tubing, if necessary, so that the fuselage tubes sit inside the seat frame corners.
- NOTE:** *The following step is necessary as the added 3D printed gun synchronization mechanism extends the length of the engine.*
10. Test fit the front firewall (A46) and the completed engine into the fuselage. File and sand away the existing aperture at the top of the firewall large enough to allow access for the gun synchronization mechanism. This will also require cutting out the centre section of the top tube of the firewall.

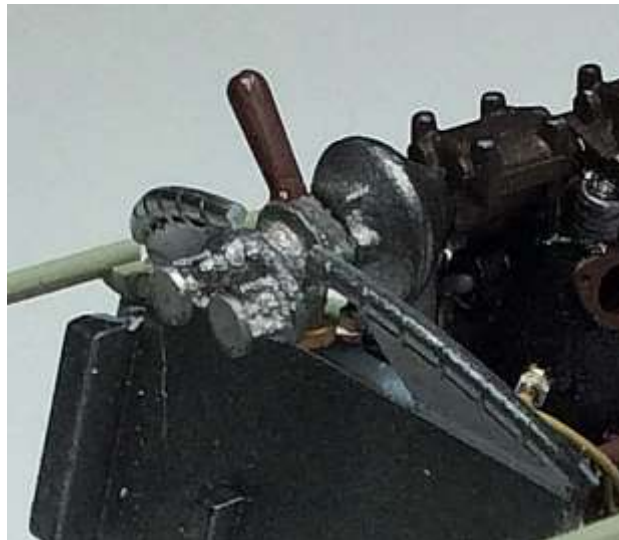

11. Remove the front firewall (A46), pilot's seat frame (A26) and the engine.
12. Make sure the four brass tubes between the 3D printed fuselage and kit supplied side frames (and the are Secure the four joints, including the two cut side frames resting on the brass tubes, using CA adhesive.

WARNING: *Once the fuselage frames have been secured together, take great care when handling the assembly as until the cockpit parts have been fitted, the assembly is very weak and easily broken.*

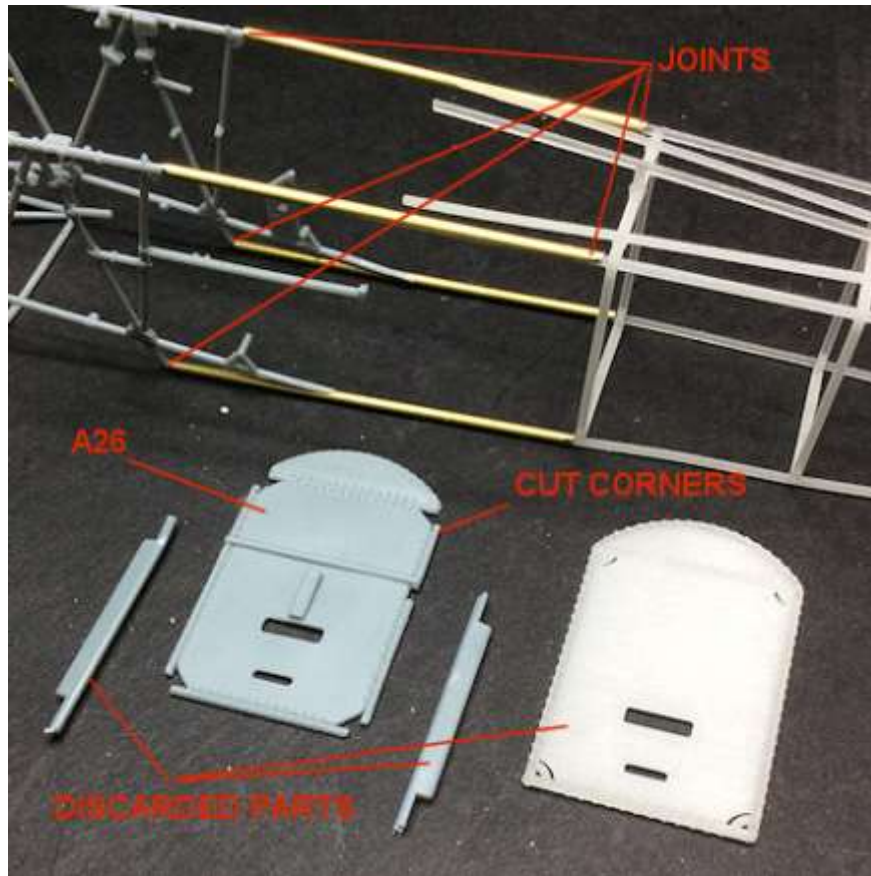

Cockpit - preparation:

13. Cement together:
 - The two halves of the ammunition tank (A49, A50).
 - The two halves of the fuel tank (A41, A42).
 - The two halves of the empty ammunition container (A51, A52).
14. Cut away the two filler caps (A58 and A60) as per the instruction manual.
15. Cement the two filler caps (A58 and A60) into the slot on the fuel tank.

NOTE: *During the next step, remember to position the control column to suit the position of the elevator and ailerons, if they are to be animated. If not the control column should be vertical and central to the torsion bar.*
16. Cement the control column (A64) to the torsion bar (A57).
17. Cement the hand throttle (A18) to the control column.
18. Drill a 0.2 mm diameter hole into the bottom of the throttle (A20).
19. Drill a 0.4 mm diameter hole into the bottom end of the pressure pump (A59) and the back of the grease pump (A28).
20. Cement the throttle quadrant (A20), spark advance lever (A55) and pressure pump (A59) to their locations on the cockpit side frames.
21. Cement the grease pump (A28) onto the gun support rail (A16).

NOTE: *The following step is required as the 'Aviatic' pilot's seat is being fitted.*

22. On the pilot's seat frame (A46) file or sand away the location for the kit seat. Temporarily locate the 'Aviatic' seat onto the frame, using blue or white tack, positioning the seat centrally with the bottom just above the cut-out for the control cables. Cement the two seat support frames (B21, B22) in position on the seat frame (A26). Once set, carefully remove the seat.
23. Prime the following parts with Grey (AK-758):
 - Fuselage frame assembly (3D, B6, B10, B11, B14, B15, B17, A59, A20, A55)
 - Cockpit floor (A37)
 - Rudder pedals (A63)
 - Control column assembly (A18, A57, A64)
 - Aileron bell crank (A11)
 - Seat frame with seat supports (A26, B21, B22)
 - Gun support (A2)
 - Fuel gauge support (A8)
 - 'Aviatic' pilot's seat cushion
 - Instrument panel (A40)
 - Magneto (A5, A29)
 - Gun support (A16, A28)
 - Compass (A62)
 - Cockpit frame corners (D5 x3, A32).
24. Prime the following parts with 'Alclad' Gloss Black Base (ALC-305) and once dry with Duraluminium (ALC-120):
 - Empty ammunition rounds container assembly (A51, A52)
 - Ammunition container (A49, A50)
 - Front firewall (A46)
 - Fuel tank assembly (A41, A42, A58, A60)
 - 'Aviatic' pilot's seat.
25. Airbrush the cockpit floor (A37), instrument panel A40) and the cockpit compass support with Deck Tan (XF55).
26. Airbrush/brush paint the following parts with 'Tamiya' Grey Green (XF76):
 - Fuselage frame assembly (3D, B6, B10, B11, B14, B15, B17, A59, A20, A55)
 - Rudder pedals (A63)
 - Gun support (A2)
 - Fuel gauge support (A8)
 - Gun support (A16, A28)
 - Cockpit frame corners (D5 x3, A32)
 - Seat frame (A26) with seat supports (B21, B22)
 - Brush paint the top of the front firewall (A46).
27. Airbrush the following parts with 'Tamiya' Rubber Black (XF85):
 - Rudder pedals (A63)
 - Control column assembly (A18, A57, A64)
 - Aileron bell crank (A11)
 - Magneto starter (A29)
 - Compass (A62).

28. Brush paint the handles of the control column hand throttle and grip (A18), spark advance lever (A55), throttle (A20), pressure pump (A59), grease pump (A28) 'Tamiya' Hull Red (XF9).
29. Brush paint the body of the pressure pump (A59) and grease pump (A28) with 'Mr. Colour Brass (219) mixed with Copper (215).
30. Brush paint the throttle quadrant (A20), spark advance lever (A55), magneto handle (A28) with 'Mr. Colour' Stainless Steel (213).
31. Airbrush the fuel tank assembly with a very light coat of 'Tamiya' Dark Green (XF61), such that the Duraluminium undercoat slightly shows through. Once dry very lightly scuff the surface with a fine sand paper to create 'wear' marks.



32. Brush paint the 'Aviatic' pilots seat cushion (A27) with 'Tamiya' Hull Red (XF9), highlighted with 'Humbrol' Leather (62).
 33. Cut thin strips of buff coloured masking tape and position the on the ammunition to create the webbing. Push the tapes into the grooves between the ammunition rounds and secure in position using 'Tamiya' Matt (X35).
 34. Apply a gloss sealing coat onto the face of the fuel gauge (A8) and compass (A62), the seat frame (A26) and the front firewall (A46).
 35. Decals:
 Following the kit instructions, apply to their locations decals 96 to 103 and 105 to 108.
 Using the kit supplied decals and 'cut out' shapes, apply matching light lozenge to both sides of the seat frame (A26) and darker lozenge to both sides of the top of the front firewall (A46).
 36. Brush paint the cut top tube of the frame for the front firewall (A46) 'Mr. Colour' Stainless Steel (213).
 37. Cement the magneto starter (A29) into its location on the instrument panel (A40).
 38. Cement handle (A5) onto the magneto starter (A29).
- Wood effect: (refer to Part 2 of this build log) - The cockpit floor, instrument panel and cockpit compass support were wood. The wood effect can be crated either by the use of decals, photo-etch airbrushing templates or by brush painting with oil paint. I chose oil painting.
39. Apply the chosen wood effect to the cockpit floor (A37) and instrument panel (A40).

40. Brush paint the foot skid plates on the cockpit floor (A37) and the ignition switch on the instrument panel () A40) using 'Mr. Colour' Stainless Steel (213).
41. Brush paint the three filler caps (A58, A60), the ammunition rounds (ammunition tank (A49, A50) and ignition switch and selector levers on the instrument panel (A40 with 'Mr. Colour' Brass (219).
42. Cement the fuel gauge frame (A8) into its locations on the fuel tank assembly (A41, A42).
43. Cement the gun support frame (A2) into its location on the ammunition container assembly (A49, A52).
44. Cement the ammunition containers assembly (A2, A49, A52) onto the fuel gauge frame (A8) locations on the fuel tank assembly (A41, A42).

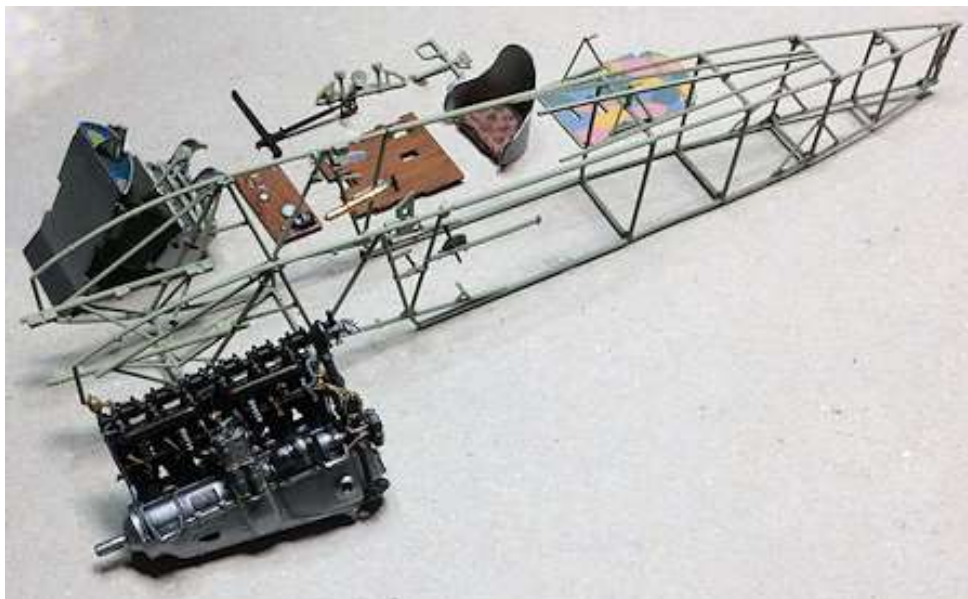

45. **Flight controls:**

Refer to the Wingnut Wings instruction manual page 8 for the general rigging illustration.

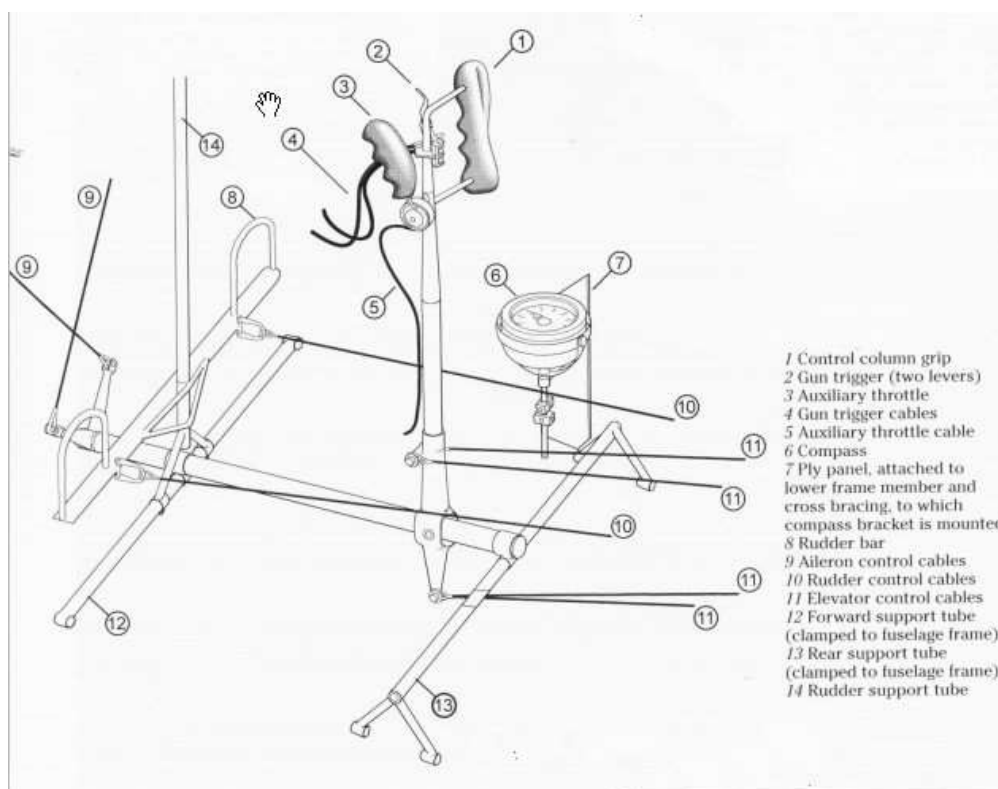

NOTE 1: *There is limited information or photographs of aircraft taken at the time that fully illustrate the internal controls or rigging of the aircraft. My primary sources of reference were:*

Albatros Productions - Windsock - Data file No.9 - Fokker D.VII (P.M. Grosz).

Albatros Productions - Fokker D.VII Anthology 1, 2 and 3 (Ray Rimell).

Kagero Publishing - Fokker D.VII The Lethal Weapon (Tomasz J. Kowalski and Marek Rys).

NOTE 2: *Source information shows the turnbuckles for adjusting the tension of the rudder and elevator control cables being either under the pilot's seat in the cockpit or further back in the fuselage, behind the pilot's seat support frame. I chose the to fit the turnbuckles under the pilot's seat.*

Rudder:

The rudder was controlled by a single cable attached to each side of the rudder bar. The cables were routed rearwards to be connected to each side of the rudder control horn.

NOTE: *Inboard from each foot guard on the rudder bar is a pre-molded attachment for a control cable.*

1. At the attachment locations, drill a hole of 0.2 mm diameter through the rudder bar (front to rear).
2. Pass a long length of 'Stroft' 0.08 mm diameter mono-filament through one hole then back through the other hole.
3. Slide a cut length of 'Albion Alloys' 0.4 mm diameter Nickel-Silver tube (NST04) onto each cable and secure close to, but not touching, the rudder bar, using thin CA adhesive.

Elevator:

The elevator was controlled by four cables. Two were attached to the bottom of the control column and routed rearwards to be connected to the control horns on the underside of the elevator. A second pair of cables were attached slightly higher on the control column and were routed rearwards and connected to the control horns on the top of the elevator.

NOTE: *Towards the bottom of the control column are the attachments for the two 'twin' operating cables. One is a small pre-molded 'cross bar' and the other a 'lug' at the very bottom of the control column.*

1. At both locations, drill a hole of 0.2 mm diameter through the control column (side to side).
2. Pass a long length of 'Stroft' 0.08 mm diameter mono-filament through each hole.
3. Slide a cut length of 'Albion Alloys' 0.4 mm diameter Nickel-Silver tube (NST04) onto each cable.
4. Gently pull the pairs of cables away from the control column (towards the short end of the torque tube).
5. Position the tubes close to, but not touching the control column, and secure them and the cables together using thin CA adhesive. Make sure the cables are free to move in the control column.

Ailerons:

NOTE: *The aileron control cables were routed from the bell crank and between the fuel tank and empty ammunition belt container to the fuselage apertures. This needs to be accounted for when building and rigging the flight controls.*

The ailerons on each side of the upper wing were connected by twin cables to the aileron bell crank (A11) on the forward end of the control column torsion bar (A57). Each pair of aileron control cables were attached to the opposite side of the bell crank lever and exited through apertures on the sides of the fuselage and up to the underside of the upper wing at the rear cabane strut attachment.



NOTE: *The following explanation of the aileron control cable routing is partly based on supposition, due to a lack of information.*

Fitted on the rear of the upper wing rear spar and forward of the aileron on that side, were twin control cable pulleys. Each pair of control cables were routed from the cockpit bell-crank, through the opposite fuselage sides and into the underside of the upper wing. One cable from each side of the bell-crank was routed around one of the twin aileron pulleys, then rearwards to a control horn on the aileron. *The other bell-crank cables were routed around pulleys in the upper wing centre section then outboard and around the second aileron pulley and rearwards to the other aileron control horn.*

As the control column was moved to the left or right, the control cables would pull on the relevant aileron control horn to move the aileron in the correct direction, whilst the other aileron control cable was 'relaxed' to allow aileron movement. For example, moving the control column left would raise the left aileron and lower the right aileron, forcing the wing to bank to the left.

1. At the end of each of the two aileron bell-crank levers, drill a hole of 0.2 mm diameter through the levers (front to rear).
2. Pass a long length of 'Stroft' 0.08 mm diameter mono-filament through each hole.
3. Slide a cut length of 'Albion Alloys' 0.4 mm diameter Nickel-Silver tube (NST04) onto each cable.
4. Position the tubes close to, but not touching the ends of the bell-crank and secure them and the cables together using thin CA adhesive. Make sure the cables are free to move in the bell-crank.

NOTE: *These control runs will be connected to the wing mounted ailerons during Part 11 of this build log.*

46. Cement the control column assembly (A18, A57, A64) and rudder bar (A63) onto the cockpit floor (A37).



47. Cement the aileron bell crank (A11) onto the control column torque bar (A57).

48. Seat harness and attachment:

As is usual when researching information for WW1 aircraft, I found conflicting information as to the type and attachment of the pilots seat harness.

Some pilots had the seat harness replaced in the field by the more traditional lap strap. However the standard harness consisted of two shoulder straps which were joined across the chest area by a cross strap. A lap strap was located at each side of the pilots seat. Each of the four straps were fastened together by a lock pin through the strap end fittings.

The conflicting information is about how the seat harness was attached to the aircraft. There are some sources, such as the instructions for the Wingnut Wings kit and the 'HGW Models' fabric replacement seat harness, that indicate that the two lap straps were anchored by their end fittings to the bottom of the seat side mounting frames. In addition, that the two shoulder straps were attached to either the back of the seat or to the top cross bar of the seat mounting frame.

The seat was constructed from sheet metal with a plywood base. A leather seat cushion was used, but was eventually made redundant with the introduction of the 'Hienecke' parachute. The inside surface of the metal seat was usually covered with linen of either lozenge design or just clear doped linen (CDL). The seat itself was attached to the seat support frame in three places. These were the vertical supports on the front of each side support frame. The third location was an attachment plate bolting the back of the seat to the centre cross bar of the seat support frame.

I believe that it is unlikely the shoulder straps were attached to the seat support frame as low as the central cross bar. Even being held together by the cross strap, attached at that location would mean the shoulder straps being much longer than necessary and during an impact would cause the straps to push down hard on the pilots shoulders. For the same reasons I believe the straps would not have been attached directly to the seat itself.

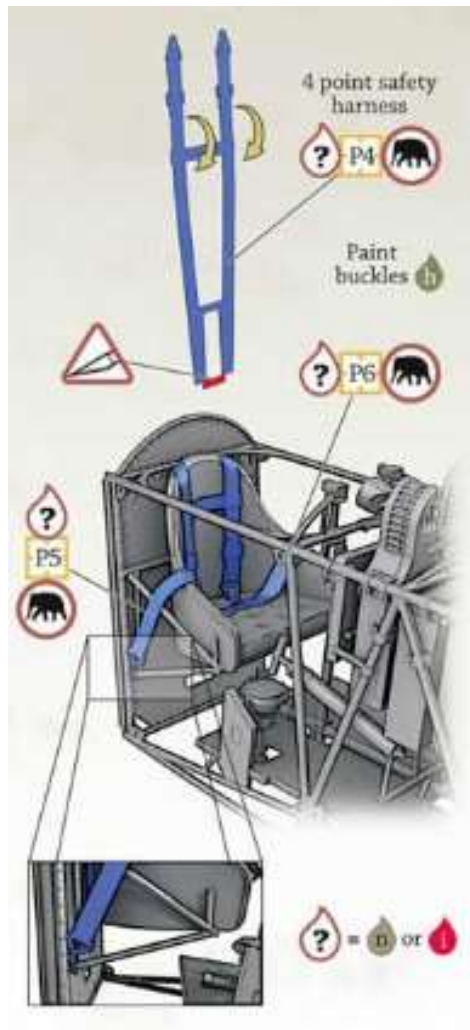
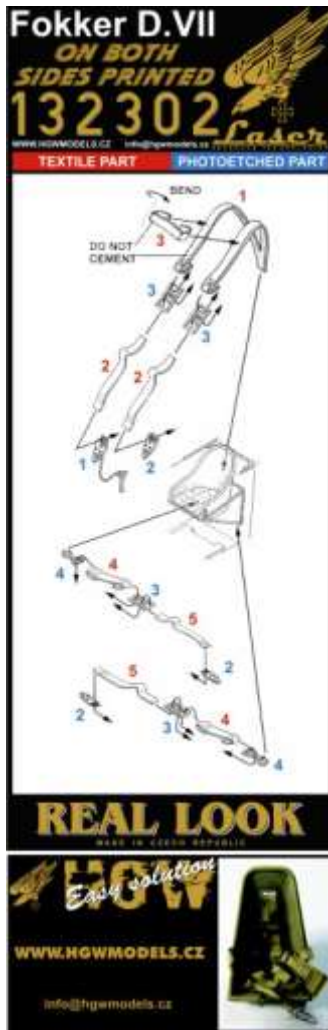

Other research information indicates that the seat harness was attached to the upper cross bar of the seat support frame and to the plywood seat base.

The two shoulder straps were looped around the upper cross bar of the seat support frame then joined together at their harness buckles below the harness cross strap. The two lap straps were looped through anchor brackets attached to each side of the plywood seat base. The straps were joined together at their harness buckles. Photographs exist of Fokker aircraft of that time, aircraft restorations and design drawings, all of which appear to support this method of harness attachment, which is the method I chose to use for this model.



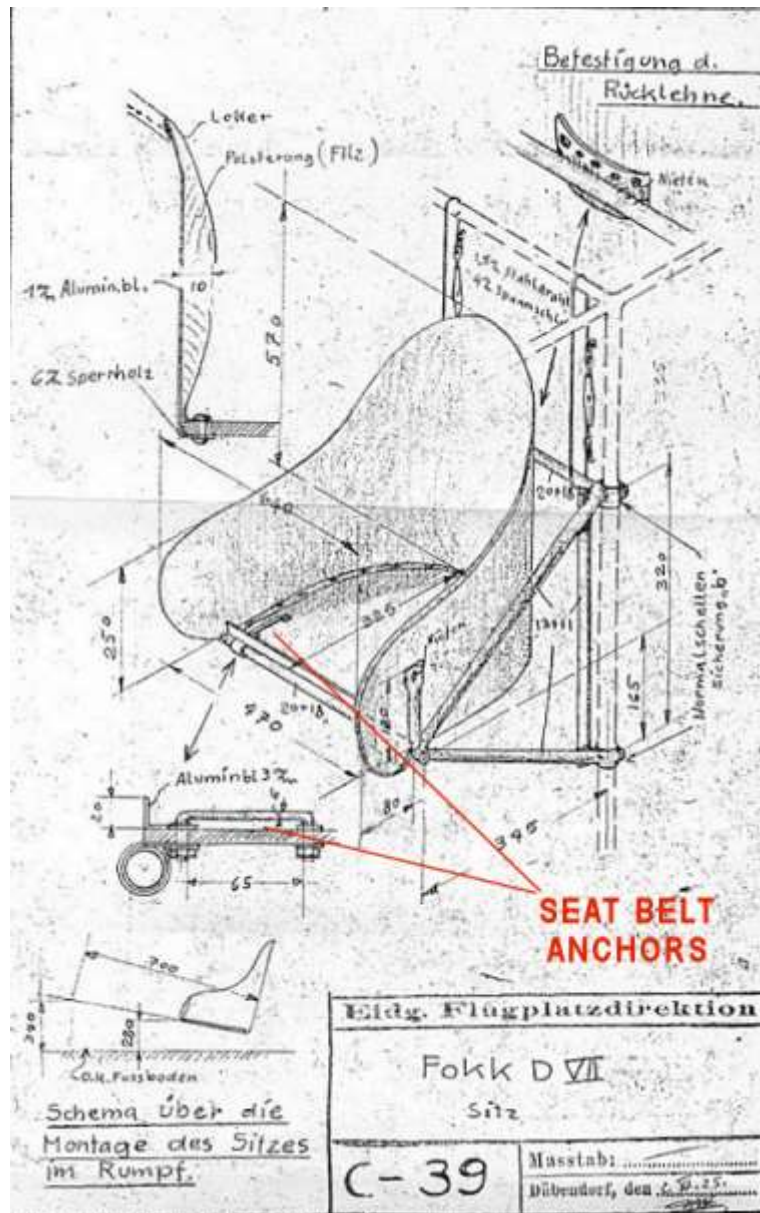
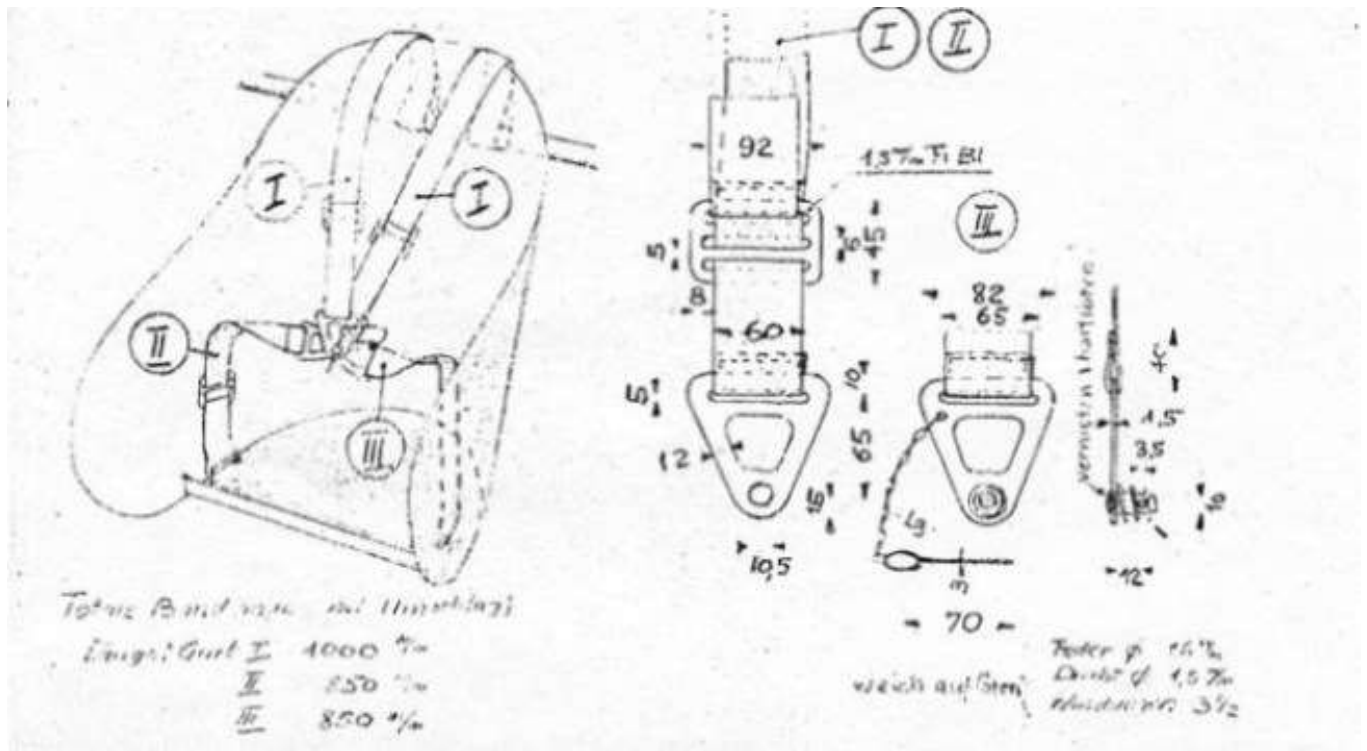

NOTE 1: *The kit supplied photo-etch seat harness will be replaced by the 'HGW Models' Fokker D.VII double sided seat belts (132302).*

NOTE 2: *Follow the 'HGW Models' instructions for basic procedures. Lap straps 4 and attachments 4 are not required.*

Dry fit the 'Aviatic' pilot's seat cushion into the seat and note where the indents are for the pilot's lap straps.

Assemble the lap straps 5 to buckles 2 and adjust their lengths to lay on the cushion.

Remove the seat cushion.

Attach the free end of lap straps 5 to the attachment locations on the pilot's seat, using CA adhesive.

Secure the pilot's seat cushion to the seat using CA adhesive.

Assemble the shoulder harness straps (straps 1, 2 and 3 - attachments 1, 2 and 3).

Using the pilot's seat as a guide, position the joined end of the shoulder straps centrally on the middle horizontal bar on the pilot's seat frame. Then adjust the length of the shoulder harness over the seat, as desired.

Secure the shoulder harness to the pilot's seat frame using CA adhesive.

Secure the pilot's seat to the seat frame and the two side support frames, using CA adhesive.



49. Pipes:

The components in the cockpit were connected to the engine, fuel tank, water pump and oil pump. These should be added to cockpit components before the cockpit and engine are fitted into the fuselage, as access afterwards will be restricted.

NOTE: *Information on these components and their connections is difficult to obtain, therefore some are based on research and on assumptions (best guess).*

Information only:

There seems on some photographs, that wires or pipes were connected to the twin carburettors. However I could not find any information as to what they were for and what they were connected to. Also those photographs show these fitted to the 200 hp D.IIIaü (over compressed) engine, which is not the engine modelled for this build. Therefore I disregarded these pipes for this build.

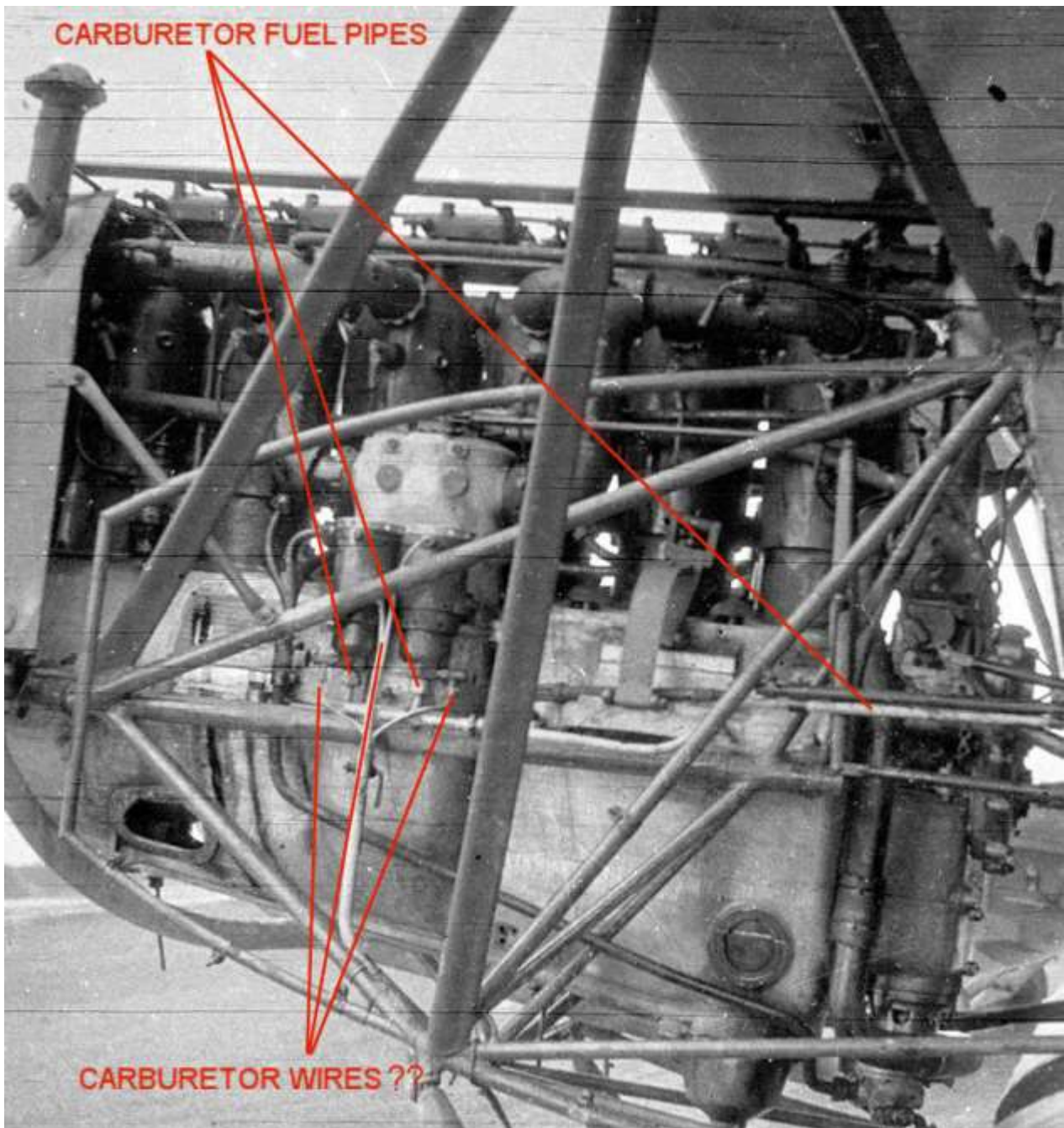

50. Fuel tank pipes:

The fuel tank consisted a primary and auxiliary fuel tank and a separate, integral oil tank.

A fuel drain valve was fitted in the bottom of the tank and was connected to a pipe, which drained out the fuel through the fuselage under the cockpit.

Two pipe connections were fitted to supply fuel from the main and auxiliary fuel tanks to the fuel distribution gallery behind the instrument panel.

A pipe connection at the bottom right of the fuel tank was to the integral oil tank and supplied lubricating oil to the engine driven oil pump.

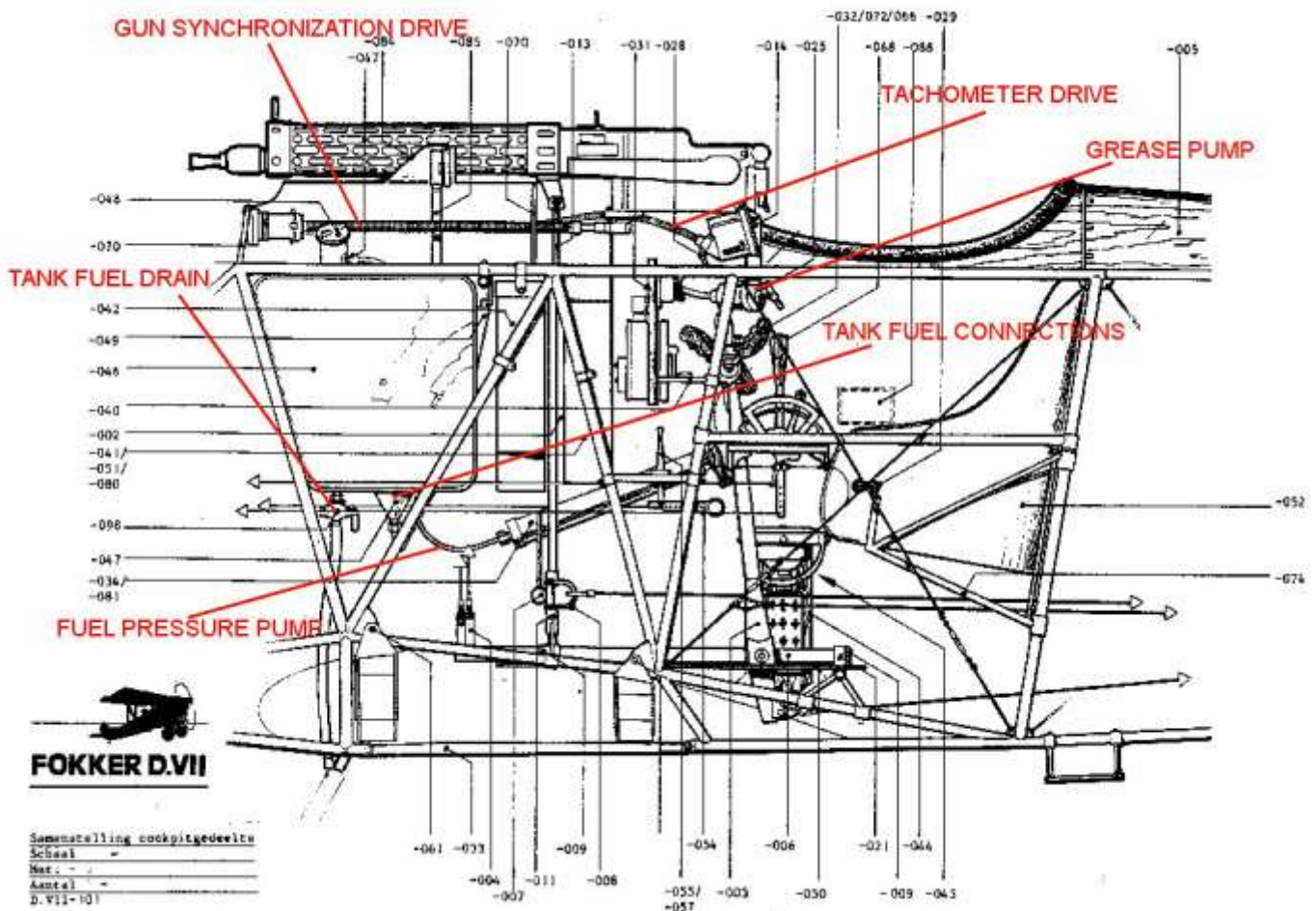

Drill four 0.6 mm diameter holes - three equally spaced, across the centre line on the bottom of the fuel tank (one in each tank segment) and one forward from the centre hole.

Cut four lengths of 'Albion Alloys' 0.5 mm diameter brass tube (MBT05).

Clear any metal burrs by running a 0.3 mm diameter drill through each cut tube.

Locate a cut tube into each of the pre-drilled holes leaving it proud of the tank surface.

Secure in position using CA adhesive.



51. Fuel supply gallery:

NOTE: *This fuel supply gallery is a simplified version of what was fitted to the actual aircraft. The four fuel selectors on the instrument panel were connected to a fuel distribution gallery behind the instrument panel. This gallery was connected to supply pipes from the fuel tanks, the dual carburetor and the fuel pressure gauge.*



Cut a length of 'Albion Alloys' 0.8 mm diameter brass tube (MBT08). The length should be from the top selector 'stub' on the rear of the instrument panel to just below the bottom edge of the panel.

Drill two holes of 0.4 mm diameter through the tube and one hole through just one side of the tube (*refer to the following photograph*).

Cut three lengths of 'Albion Alloys' 0.3 mm diameter brass tube (MBT03).

Pass the tubes through and into the 0.8 mm tube and secure in position using CA adhesive.

Cut and bend to 90 degrees a short length of 'Albion Alloys' 0.3 mm diameter brass tube (MBT03).

Insert this 90 degree tube into the top of the 0.8 mm tube with the bend facing the top selector 'stub'.

Drill a 0.4 mm diameter hole part way into the centre of the top selector 'stub'.

Cut away the ends of the upper 0.3 mm diameter brass tube so the ends are central with the two upper selector 'stubs'.

Bend the lower left 0.3 mm diameter brass tube 90 degrees to align with the lower left selector 'stub'.

Bend the two upper right 0.3 mm diameter brass tubes 90 degrees down towards the bottom of the instrument panel.

Cut two short lengths of 'Albion Alloys' 0.3 mm diameter brass tube (MBT03).

Slide the two cut tubes part way onto the two bent 90 degree tubes and secure using CA adhesive.

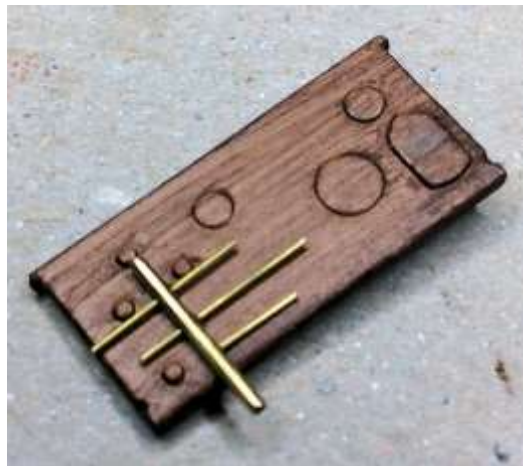

Locate the created manifold onto the rear of the instrument panel with the top bent pipe into the pre-drilled hole. Secure in position using CA adhesive.



52. Fuel pressure gauge:

The fuel tank pressure gauge was connected by a pipe to the fuel distribution gallery on the rear of the instrument panel.

Cut a short length of 0.2 mm diameter copper wire.

Bend the wire to 90 degrees.

On the back of the instrument panel, offer up the wire to the back of the fuel pressure gauge across to the nearest distribution gallery 'stub'.

Trim the ends of the wire so they lay central on the 'stub' and pressure gauge.

Secure the wire in position using CA adhesive.

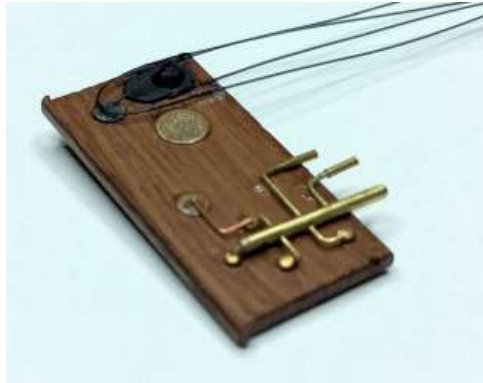

53. Pressure pump:

The pilot operated fuel pressure pump, mounted on the cockpit right side frame, was connected to the fuel tank by a pipe. As where it was connected to the fuel tank is not clear. As it was used to pressurize the fuel in the fuel tank, I chose to connect the pipe to the top of the fuel tank.

NOTE: *The end of the pressure pump was pre-drilled before it was fitted.*

Cut a length of 0.28 mm diameter copper wire.

Drill a 0.4 mm diameter hole into the top, forward left of the fuel tank.

Bend the copper wire to run from the pressure pump, up the right side of the fuel tank and cross the front of the tank to the drilled hole. Secure in position using CA adhesive.



54. Electrical wires:

1. From the magneto starter directly to the centre stub on one engine magneto.
2. From the starter magneto to the ignition switch then to the two magneto distributors.
3. From the starter switch to 'earth (ground)'
4. From the engine driven generator (usually only fitted for supplying power to electrically heated flying suit or for a wireless transmitter) to the cockpit.

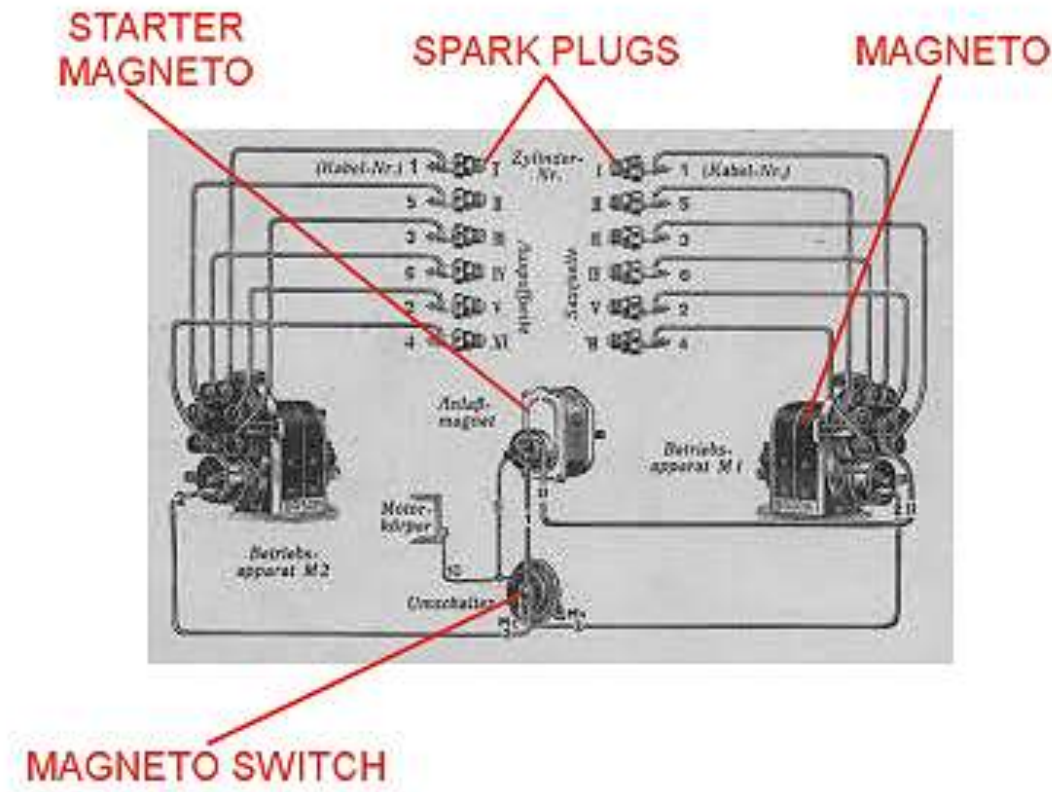

Engine start sequence (ground crew) (information only):

- **Turn ignition switch to Off**
- Retard Ignition (spark advance lever - ignition timing)
- Throttle closed (throttle lever)
- Decompression lever to De-compress (lever pointing down) (rear of engine)
- Hand rotate the propeller 6 revolutions. This will draw a fresh fuel mixture charge into each cylinder
- Close de-compression lever (rear of engine)
- **Ignition switch to M1 (start)**
- **Rapidly turn the Hand Start Magneto - Engine will fire**
- Idle at 200-250 rpm for 5 to 10 minutes
- Slowly increase revolutions to 600 rpm (throttle lever)
- **Ignition switch to M2 and check for rpm drop (magneto check)**
- **Ignition switch to 2 and move ignition advance lever to mid position**
- When running cleanly, fully advance ignition (spark advance lever) and check full throttle against rpm reading. When engine checks are complete, idle at 300 – 350 rpm until the pilot is in the airplane.

NOTE: *At this stage only the wire between the ignition switch and starter magneto and the supply from the ignition switch to the engine magnetos can be added.*

Cement a small piece of cylindrical 'sprue' to the back face of the starter magneto on the instrument panel.

Brush paint the 'sprue' with 'Tamiya' Rubber Black (XF85).

Cut a short length and a long length of 'T-Force' XPS 0.148 mm line.

Secure the short length between the 'sprue' and the back of the ignition switch, using CA adhesive.

Secure the long length across the back face of starter magneto, using CA adhesive.

Pull the long length to each side of the starter magneto and secure in position using CA adhesive.

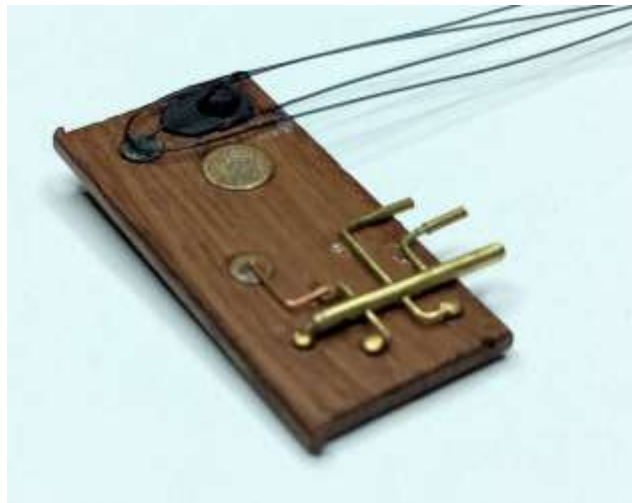

NOTE: *Refer to the 'Wingnut Wings' instruction manual.*

55. Locate then secure the firewall, fuel tank and ammunition containers assembly into the fuselage using CA adhesive.
56. Locate and secure the cockpit floor assembly into the fuselage using CA adhesive.

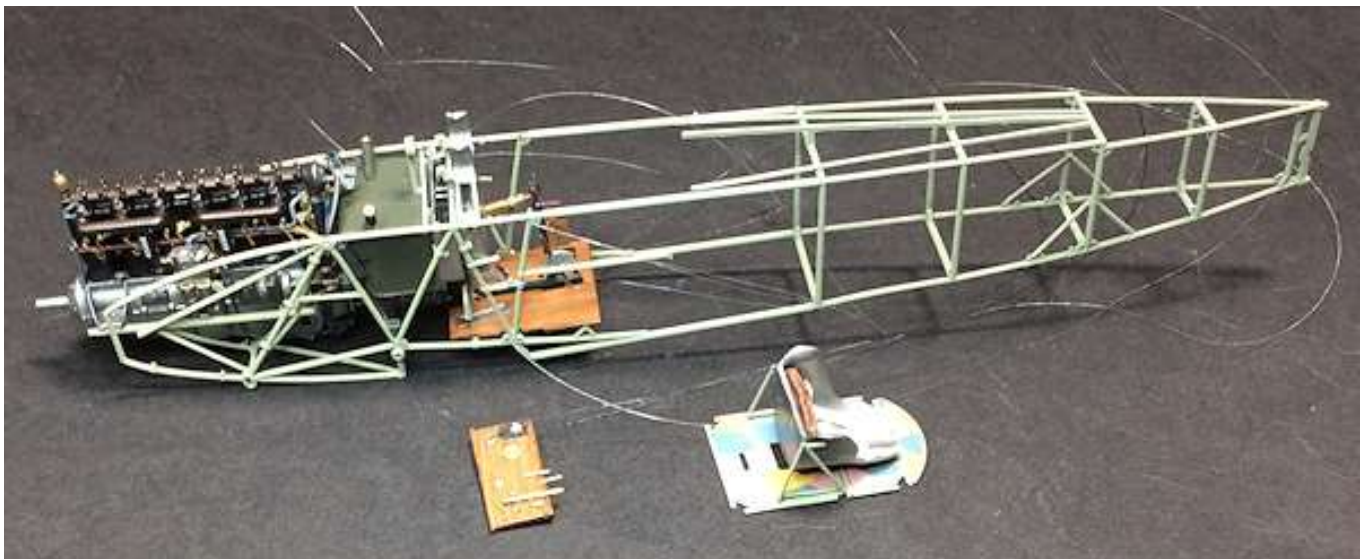

57. Position the pilot's seat frame assembly into the 3D printed fuselage. The top of the frame should be angled rearwards with the bottom forwards. The kits cockpit left side frame has a horizontal tube which should locate into the cut out in the left side of the seat frame.
58. Make sure the four corners of the seat frame fit onto the fuselage frame and the left horizontal tube locates into the left side of the seat frame.

NOTE: Any gaps between the seat frame and the fuselage structure can be filled by inserting cut 'Albion 'Alloys' 1.2 mm diameter brass micro-tube (MBT12) or similar sized plastic rod, both of which should be secured using CA adhesive.

59. Secure the seat frame in position using CA adhesive.



NOTE: The gun support frame should be in-line with the tubes of the cockpit side frames below it.

60. Carefully cut away the location lug for the kit supplied head protectors, which are located on the back face of the gun support frame (A16), as the kit supplied head protectors are not required. Locate the gun support frame into its location holes at the top of the cockpit side frames and secure in position using CA adhesive.
61. Locate the instrument panel assembly into its locations at the top of the cockpit side frames and against the tubular 'stop' bars and secure in position using CA adhesive.

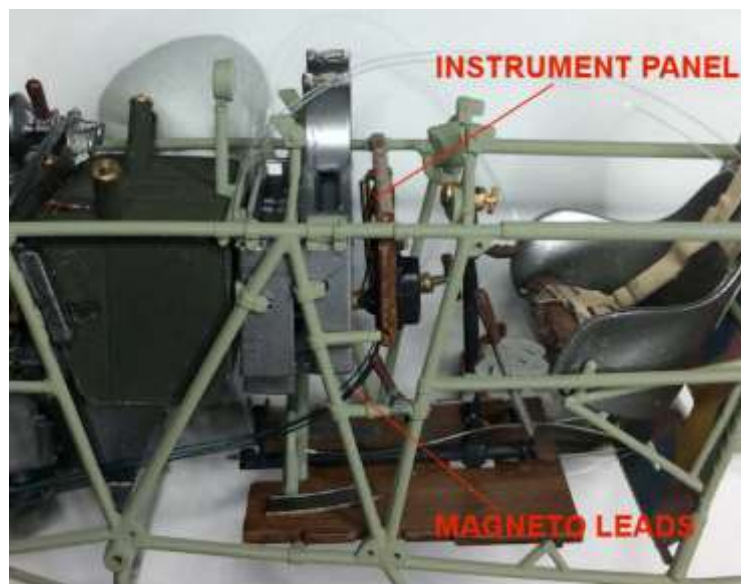

62. Cement in position the front left and two rear corner braces (D5) on the cockpit framing.
63. Cement the altimeter (A32) into the right front corner of the cockpit framing.
64. Locate the compass into its mounting at the lower right on the cockpit floor and cement in position.
65. Grease pump pipe:

A pipe was connected to the rear of the hand operated grease pump, located on the left, upper of the gun support frame. This was a 'screw down' pump, which the pilot operated approximately every ten minutes to supply lubricating grease to the water pump, located at the bottom rear of the engine sump.

NOTE: *The connection for the pipe to the grease pump was pre-drilled.*

Cut a long length of 0.3 mm diameter 'tinned' copper wire.

Apply heat along the wire to dull the metallic sheen of the wire.

Drill a hole a 0.4 mm diameter into the right side of the engine mounted water pump, above the location stub for the radiator coolant pipe (B19).

Secure one end of the wire into the pre-drilled hole in the grease pump, using CA adhesive.

Carefully bend the wire over the top edge of the instrument panel, then left along the back. Bend the wire down and forward along the right, underside of the fuel tank then through the opening in the firewall. Bend the wire across the front face of the firewall towards the engine, then down at an angle to the hole drilled in the water pump.

Using CA adhesive to secure the wire to the instrument panel, fuel tank, firewall and water pump.

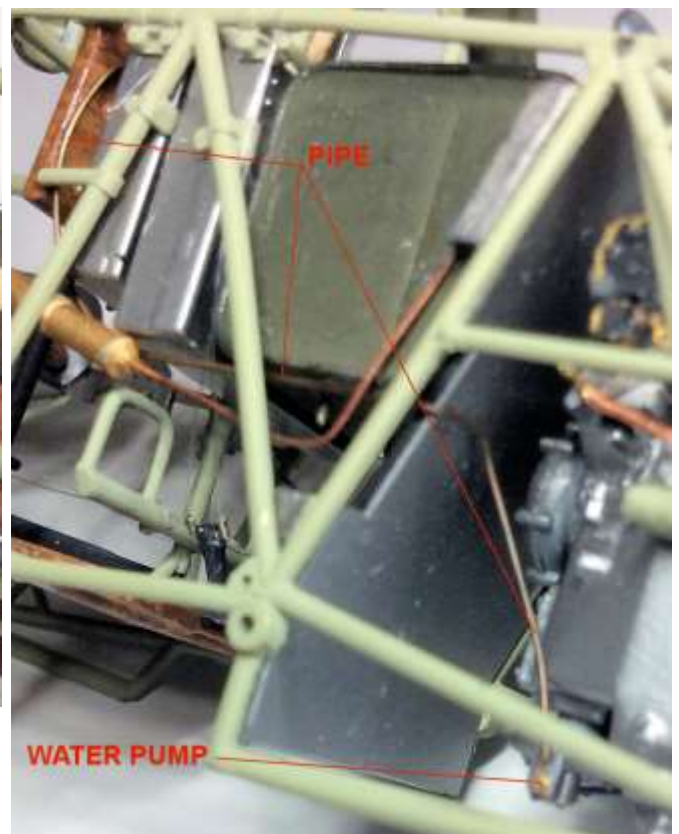
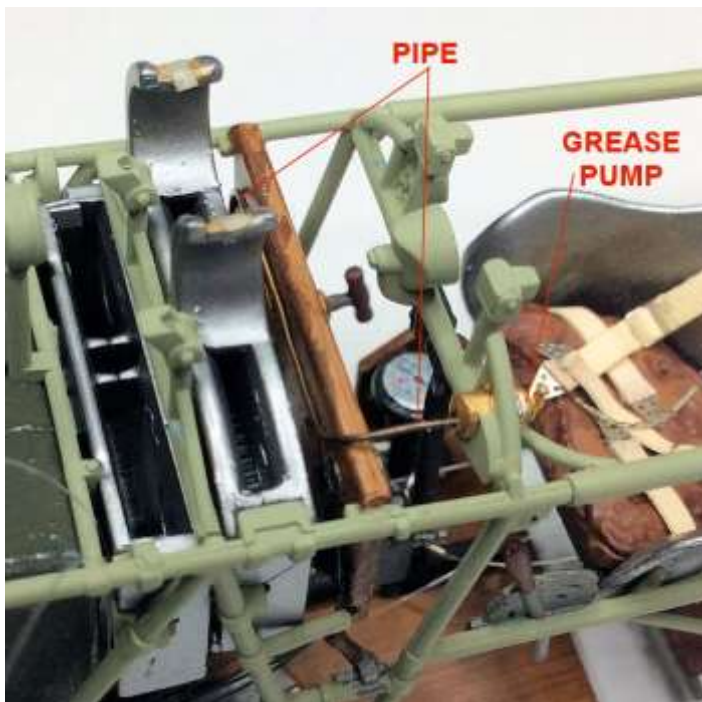

66. Fuel drain pipe:

A fuel drain valve was fitted in the bottom of the tank and was connected to a pipe, which drained out the fuel through the fuselage under the cockpit. The pipe was routed from the bottom of the fuel tank and through the firewall to the bottom cross tube of the fuselage.

Cut a long length of 0.3 mm diameter 'tinned' copper wire.

Apply heat along the wire to dull the metallic sheen of the wire.

Drill a hole a 0.8 mm diameter through the firewall. The hole should be in-line with the pre-installed 0.5 mm connection in the front centre of the fuel tank underside.

Pass the wire from the front of the firewall and through the drilled hole then secure the end into the connection tube, using CA adhesive.

Carefully bend the wire to drop vertically down the front face of the firewall to just below the fuselage bottom cross tube.

Slide onto the end of the wire a short cut 'Albion Alloys' 0.5 mm brass tube (MBT05).

Secure the wire and tube in position using CA adhesive.

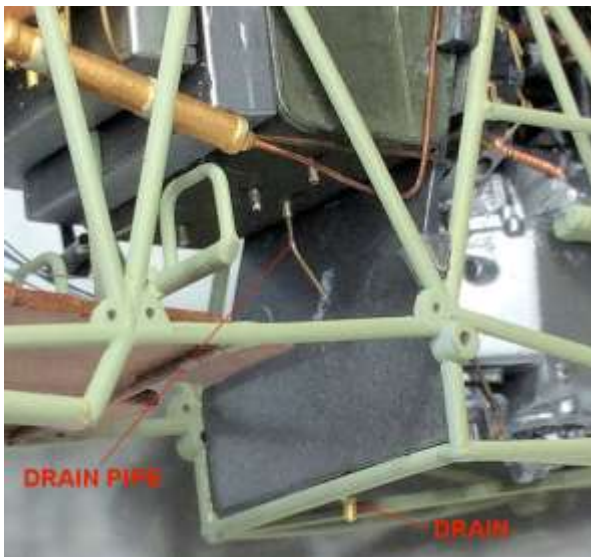

67.

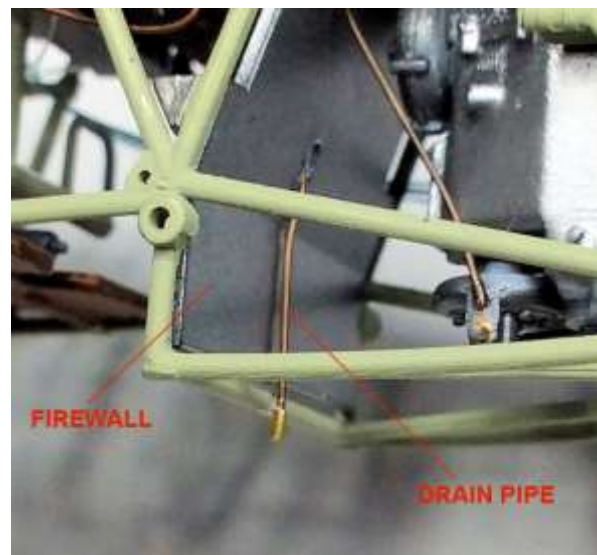

67. Fuel pipes:

Two pipe connections were fitted to supply fuel from the main and auxiliary fuel tanks to the fuel distribution gallery behind the instrument panel.

Cut two long lengths of 0.3 mm diameter 'tinned' copper wire.

Apply heat along the wire to dull the metallic sheen of the wire.

Pass each wire under the instrument panel and insert them into the pre-installed tubes on the fuel gallery on the back of the panel.

Secure each wire in its tube using CA adhesive.

Carefully bend the wires under the instrument panel and fuel tank to their tubes on the underside of the fuel tank (on the same side as the twin fillers on top of the tank).

Bend the ends of the wires to 90 degrees and insert them into their tubes.

Secure each wire in its tube using CA adhesive.

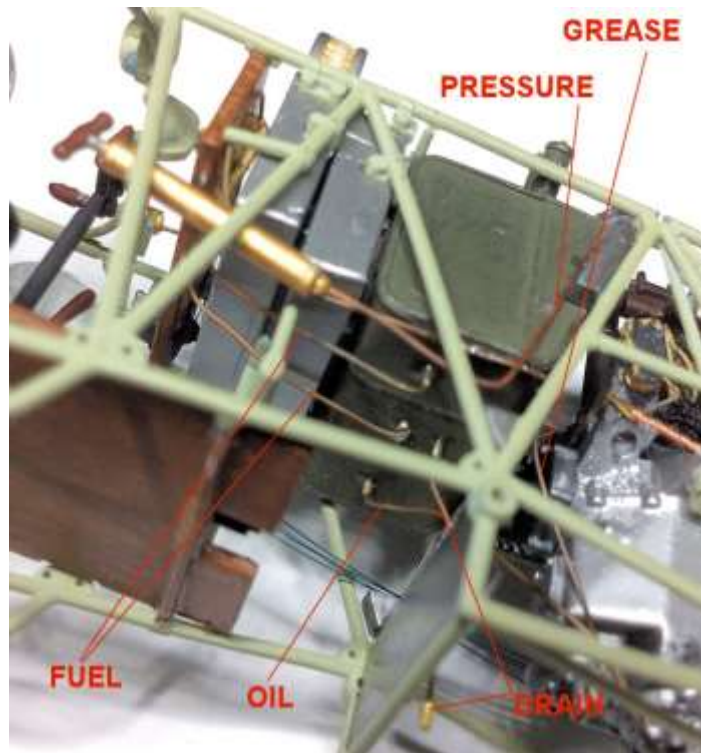

68. Oil pipe:

A pipe connection at the bottom right of the fuel tank was to the integral oil tank and supplied lubricating oil to the engine driven oil pump.

Cut a long length of 0.3 mm diameter 'tinned' copper wire.

Apply heat along the wire to dull the metallic sheen of the wire.

Insert one end of the wire into the remaining tube on the underside of the fuel tank.

Secure the wire in the tube using CA adhesive.

Bend the wire through the opening made for the fuel drain pipe.

Bend the wire down to the engine mounted oil pump.

Trim the end of the wire and secure to the oil pump using CA adhesive.



69. Carburetor feed pipes:

Two pipes were connected to the fuel gallery behind the instrument panel and were routed down and under the ammunition containers and fuel tank to the opening at the left side of the firewall. The pipes were then routed forwards and along the engine frame to connect to the bottom of the two carburetors.

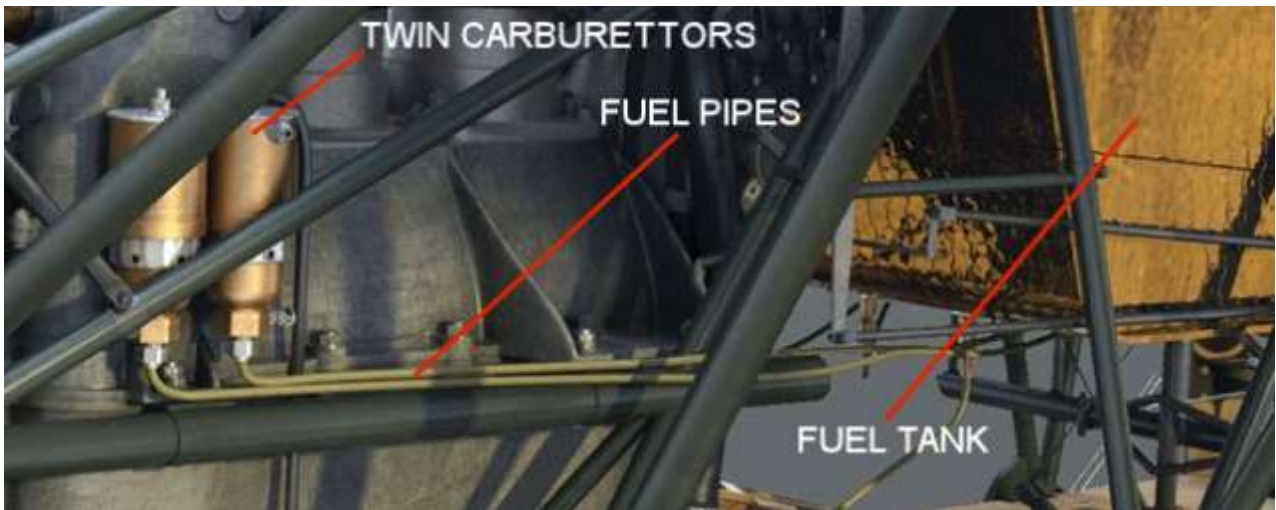

Cut four long lengths of 0.3 mm diameter 'tinned' copper wire.

Apply heat along the wire to dull the metallic sheen of the wire.

On two of the wires bend the ends to a short 90 degrees.

Position the bent ends of the two wires against the bottom of the two carburetors with the straight ends in the opening in the firewall.

Trim the wires flush to lay in the opening.

Secure the two wires in position using CA adhesive.

On two remaining wires bend the ends to a 90 degrees.

Pass each wire under the fuel tank and ammunition containers and above the rudder bar.

The 90 degree bend needs to be inserted behind the instrument panel with the straight ends in the opening in the firewall.

Trim the wires to touch the fitted wires from the carburetors.

Secure the two wires in position using CA adhesive.

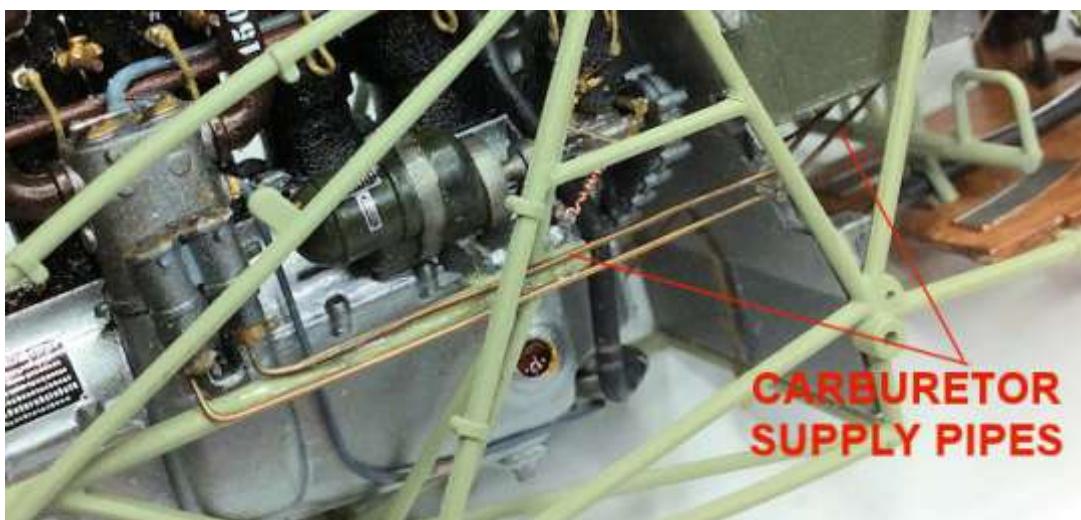

70. Tachometer drive cable:

The tachometer mounted on the centre of the gun support frame was driven by a cable connected to the gun synchronization mechanism at the top, rear of the engine.

Cut a length of 0.4 mm diameter lead wire ('PlusModel') long enough to fit between the back of the tachometer then forward (to the side of the tank contents gauge support) to the centre location on the gun synchronization mechanism. The wire should droop slightly between connections.

Secure the wire to the tachometer, edge of the ammunition container, fuel gauge support and the gun synchronization mechanism. Use CA adhesive.



71. Gun trigger cables:

The two gun trigger cables hung forwards from the control column and were routed under then up the back of the instrument panel, then forwards to the engine mounted gun synchronization mechanism, which was driven by the engine camshaft in synchronization with the rotation of the propeller. When operated they would engage the flexible drive shafts, which in turn would drive machine guns.



Cut two lengths of 0.3 mm diameter lead wire ('PlusModel') long enough to run from the gun synchronization mechanism, over the fuel tank and ammunition containers, down behind the instrument panel then loop back up to the triggers on the control column.

Secure one end of each wire to the gun synchronization mechanism (one each side of the installed tachometer drive cable) using CA adhesive.

Route the two wires rearwards to the gap between the ammunition container and the instrument panel.

Pass the wires down the gap into the cockpit, then loop both wires up to the triggers on the control column.

Trim the ends of the wires with scissors so they touch the triggers with a loop half way down the control column.

Secure the two wires to the triggers using CA adhesive.

Use a suitable tool, such as a wood tooth pick, to arrange the looped wires to hang more naturally.



72. Electrical wires:

From the magneto starter directly to the centre stub on one engine magneto.

From the starter magneto to the two magneto distributors.

From the engine driven generator (usually only fitted for supplying power to electrically heated flying suit or for a wireless transmitter) to the cockpit.

NOTE: *This procedure will connect the magneto wiring already fitted to the engine mounted magnetos. The instrument panel wiring is already done.*

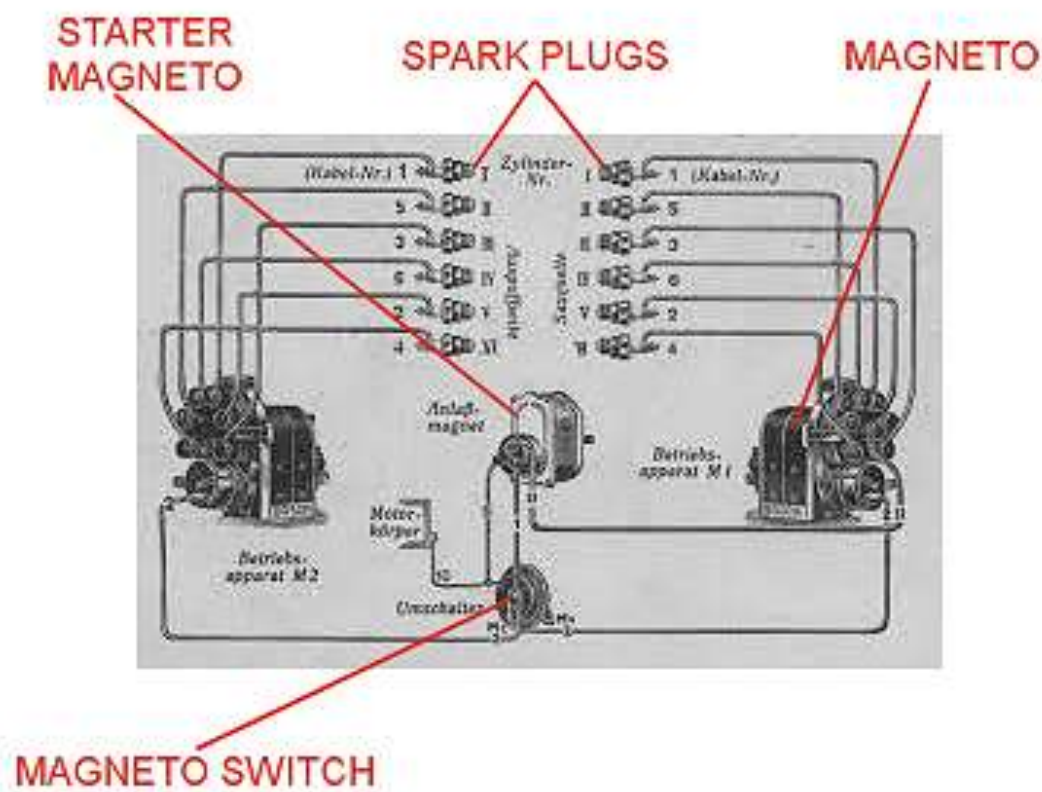

Magneto wires:

Cut a length of 'Albion Alloys' 0.6 mm diameter brass tube (MBT06) just shorter than the width of the bottom, left side of the fuel tank.

Chemically blacken the surface of the tube by dipping it in, for example, 'Blacken-It' or brush paint the tube with 'Tamiya' Rubber Black (XF85).

Secure the tube in position on the bottom of the fuel tank on the left side, using CA adhesive.

Thread the four 'wires' from the starter magneto behind the instrument panel, through the tube.

Route two of the wires to the engine left magneto. One to the centre stub between the side ignition lead connections and one to the centre of the circular distributor below.

Trim the length of the two wires.

Secure the two wires to the magneto and distributor using CA adhesive.

Route the remaining two wires across the engine, between the two magnetos and the rear of the engine.

Trim the length of the two wires and secure them to the engine right magneto, as was done at the left magneto.

Generator wires: *To be fitted after the throttle and Spark Advance controls have been installed.*



73. Spark advance control:

NOTE: This procedure will connect the spark advance (ignition timing) lever to the engine mounted components already fitted.

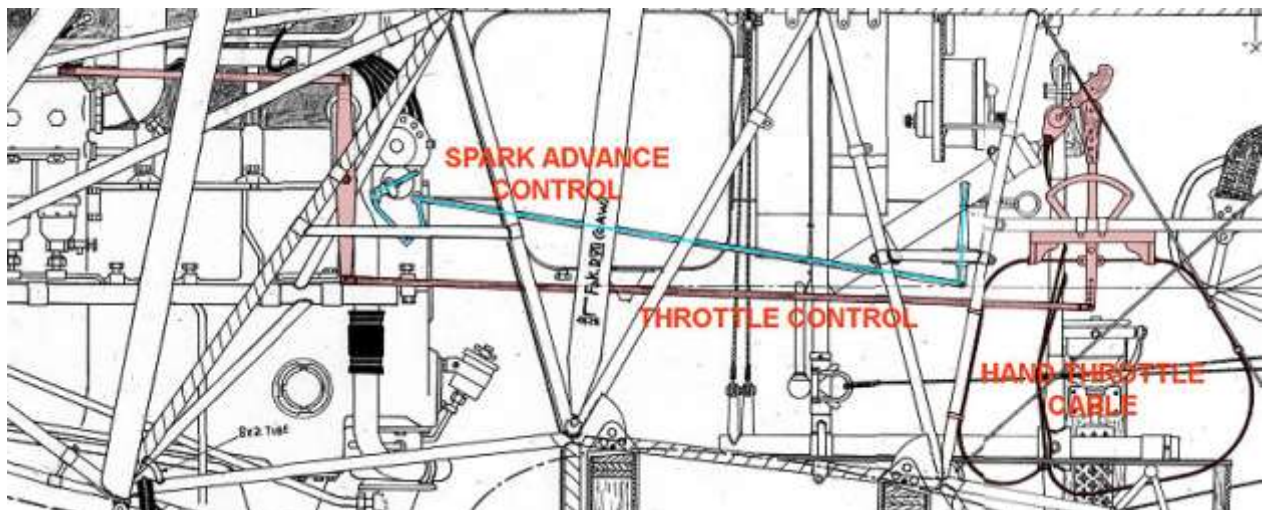

The pilot was able to manually adjust spark plug ignition using the 'spark advance' lever, located at the left cockpit side frame, forward from the throttle lever. Like the throttle lever, it was moved in an arc to either advance or retard the ignition in the cylinders. The bottom of the lever was connected by a control rod to a spindle, located across the lower rear of the two magnetos. At both ends of the spindle were linkages that were connected to the operating levers on the front of each magneto.

Cut a length of 'Albion Alloys' 0.3 mm diameter brass tube (MBT03).

Cut a short and a long length of 'Albion Alloys' 0.1 mm Nickel-Silver rod (NSR01).

Chemically blacken the surface of the tubes by dipping them in, for example, 'Blacken-It' or brush paint the tube with 'Tamiya' Rubber Black (XF85).

Bend one end of the long 0.1 mm rod to 90 degrees then trim the bend so only a short length is left.

Cut and file a 'spare' piece of photo-etch (or use plastic card) to form a short oblong 'link'.

Drill a 0.4 mm diameter hole through each end of the 'link'.

Locate the long length of 0.1 mm rod through a hole in the 'link' then slide the 'link' around the created bend. Hold the rod at a slight angle then secure the 'link' in position using CA adhesive.

Locate the short length of 0.1 mm rod through the remaining hole in the 'link'. Make sure the rod is at 90 degrees to the long rod then secure the 'link' in position using CA adhesive.

Sand away any protruding rod ends at the 'link'.



Trim the length of the long rod so it rests against the bottom of the spark advance lever and the 90 degree short rod is aligned with the installed linkage support rod at the rear of the two engine driven magnetos.

Trim the length of the short rod so it touches the installed linkage support rod at the rear of the two engine driven magnetos.

Position the control run and secure in position using CA adhesive.





74. Throttle control:

NOTE 1: This procedure will connect the throttle lever to the engine mounted components already fitted.

NOTE 2: The pivot lever for the throttle control has already been made from photo-etch. The base of the throttle lever was attached to a control rod which was routed forwards to the left, rear of the engine, where it was attached to the bottom of a pivoting lever. The lever was located on the left side frame. The top of this lever was connected by an angled control rod, to the dual carburetor operating cam.

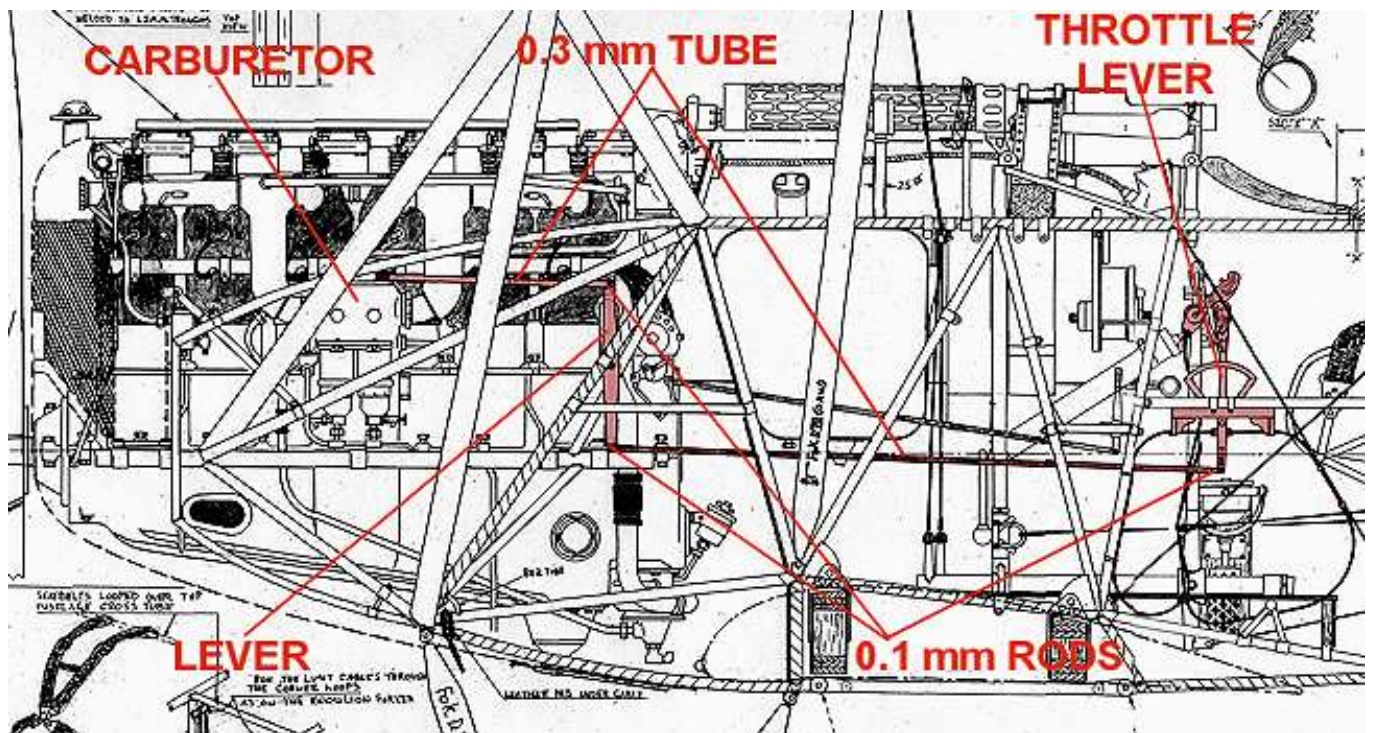

Cut a two long and one short length of 'Albion Alloys' 0.3 mm diameter brass tube (MBT03) and three short lengths of 0.1 mm Nickel-Silver rod (NSR01).

Pass two 0.1 mm rods through the holes in the ends of the created photo-etch lever and the short 0.3 mm tube through the centre hole.

Secure the three to the lever using CA adhesive.

Trim one rod flush with the side of the lever so only one side remains at 90 degrees from the lever. *This will be used to support the control rod from the top of the lever to the dual carburetor.*

Trim the remaining 0.1 mm rod flush with the lever then bend it in-line with the lever. *This will be used to support the throttle control rod from the bottom of the lever back the pilot's throttle lever.*

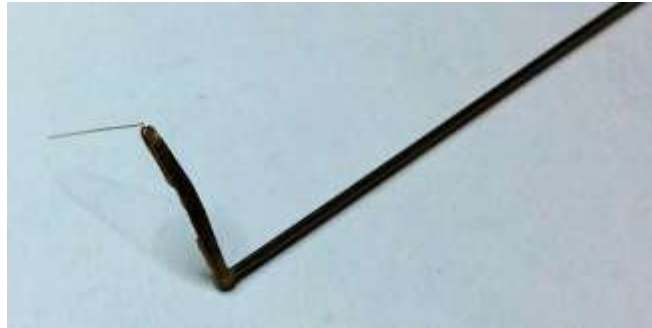

Slide each cut 0.3 mm rod onto the two 0.1 mm rods on the lever and secure using CA adhesive.

Chemically blacken the assembly by dipping it in, for example, 'Blacken-It' or brush paint with 'Tamiya' Rubber Black (XF85).

Insert the third cut 0.1 mm rod into the end of the 0.3 mm tube that will connect to the throttle lever and secure it using CA adhesive.

Bend that 0.1 mm rod to 90 degrees so it faces in towards the cockpit.

Carefully working from the engine, manoeuvre the throttle control run between the framework to position the 0.3 mm tube at the bottom of the throttle lever, the main lever between the engine frames and the top 0.3 mm tube towards the carburetor.

Locate the bent 0.1 mm rod into the pre-drilled 0.2 mm hole in the bottom of the throttle lever and secure with CA adhesive.

Position the main lever in the engine frames and secure with CA adhesive.

Angle the top 0.3 mm tube towards the pre-installed carburetor linkage and trim to length then secure in position using CA adhesive.



75. Hand throttle cable:

The hand operated throttle cable was routed down the control column and under the cockpit floor to the cockpit left side frame, where it was connected to the throttle lever. The cable was then routed back to the hand operated throttle. Moving the hand throttles either way pushed or pulled the cable, moving the throttle lever.

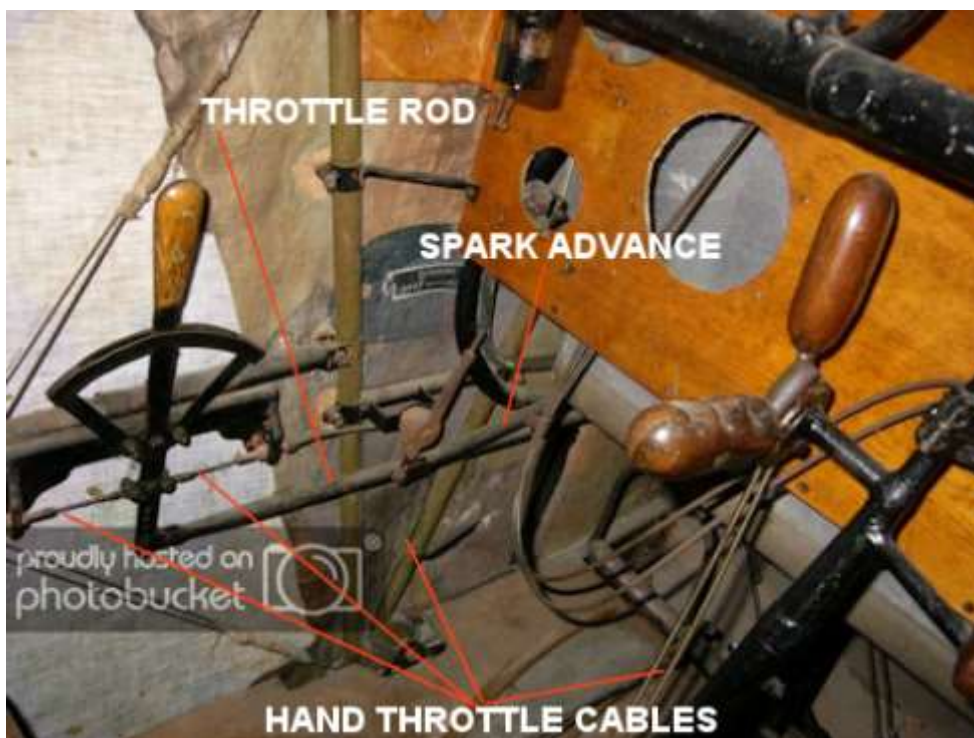
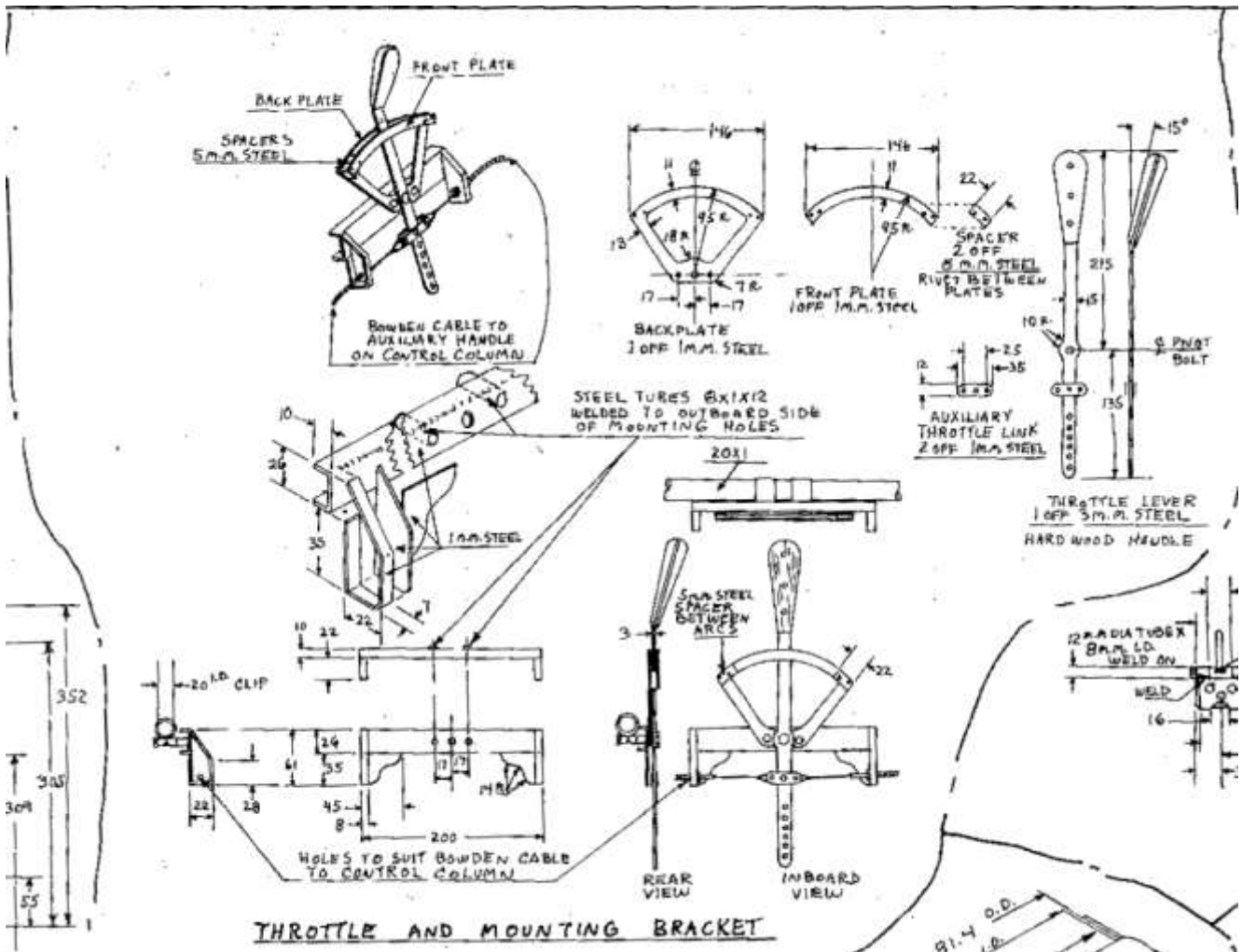

Cut a long length of 'PlusModel' 0.2 mm diameter lead wire.

Carefully pass one end of the wire down the to the opening in the cockpit floor at the base of the control column.

NOTE: *During the following steps, at intervals secure the wire to the framework using CA adhesive.*

Route the wire across the underside of the floor and forwards to the angled tube of the cockpit left side frame (that angles up and rearwards towards the throttle quadrant).

Route the wire up the frame then rearwards under the throttle quadrant to the next frame tube. The wire should be secured on the bottom of the two lugs on the throttle quadrant.

Route the wire down the bottom seat support frame then cockpit frame to the bottom frame tube.

Route the wire forwards to the underside of the cockpit floor then across to the existing wire at the floor opening.

Pass the wire up through the opening and up the control column.

Carefully pull the two wires up then bend the over the spindle of the hand throttle (one wire from each side).

Trim away excess wire then secure both in position using CA adhesive.



76. Generator wire:

An engine driven generator was only fitted to aircraft that required an electrical power supply for heated flying suits or for a wireless transmitter. The assumption is that the supply lead from the generator terminated at sockets in the cockpit.

Cut a long length of 'T-Force' XPS 0.148 mm line.

On one end of the line slide on a very short length of 'Albion Alloys' 0.4 mm Nickel-Silver tube and secure using CA adhesive.

Cut a second tube the same length as the first and position it adjacent to the line tube.

Secure the two tubes together with CA adhesive.

Position the joined tubes to the left seat support and secure using CA adhesive.

Route the line across the support tube of the throttle quadrant the up and across to the top, forward edge of the fuel tank. Pass the line down to the second 'clip' on the side frame.

Drill a 0.3 mm hole through the 'clip'.

Pass the end of the line through the hole then down the generator body.

Trim the line to length then secure the line to the generator body and at intervals along the line, using CA adhesive.



77. Radiator:

Rotary engines needed no cooling system as the engine cylinders were 'finned', similar to some modern motor cycle engines. These fins increased the surface area of each cylinder, which was then cooled by the airflow from the rotating engine and forward speed of the aircraft. However in-line engines required built in water cooling, the heat generated being dissipated by the airflow through the radiator. Thermostats were not used in these systems to control flow of coolant through the radiator. Engines are optimized to run best within a certain temperature range and with an 'open' radiator this was not always possible. Coolant from the engine passed through a connection at the top, front of the first cylinder into the radiator.

Cooled through the radiator the coolant was then drawn out of the of the radiator through two pipes, which were connected to the bottom, sides of the radiator. These two pipes were routed rearwards and combined into a single pipe, which was connected to the engine driven water pump. The pump distributed the coolant through an external pipe into the interconnected pipe gallery at the base of the cylinders. The coolant flowed up and around through each cylinder 'jacket' and then out through an interconnected pipe at the top of the cylinders then forwards to the radiator feed connection.

There were various designs of radiator fitted to this aircraft, but the type I chose for this model is of the later, high capacity type. These radiators had smaller hexagonal 'cells' in the cooling core, which allowed through more cooling airflow and the radiator walls were only 5 mm thick. The vertical centre section of the core was also wider than other designs. Finally the filler pipe was fitted outboard on the header tank whereas most designs had the filler pipe located more towards the centre of the radiator. The sides of the radiator were supported by struts attached to the fuselage side frames. A modification was carried out on some radiators in an attempt to enable the pilot to manually control the temperature of the engine. This was done by fitting a metal flap onto a hinge rod, which was attached vertically to the right, rear of the header tank and radiator bottom. A 'web' was fitted to the rear face of the flap. My assumption is that a Bowden type cable (push-pull) was connected to the outer tip of the 'web', then routed around a pulley located of the fuselage side frame and then routed rearwards into the cockpit. This allowed the pilot to manually adjust the opening of the flap and thereby control the amount of engine cooling.

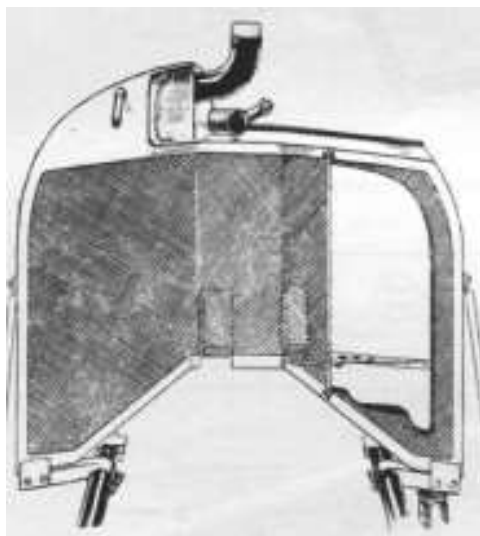

Cement the rear of the radiator (A43) into the body (A34).

Cement the filler cap (A31) to the radiator filler pipe.

Ensure the locating hole in the top, front of the first engine cylinder is clear of primer and paint.

Using the drawing above as a guide, cut the shape of the flap from 0.2 mm thick plastic card.

Using the same card, cut the angled 'web' for attaching the control rod.

Drill a 0.2 mm diameter hole through the outer end of the 'web'.

Cut a length of 'Albion Alloys' 0.4 mm Nickel-Silver tube (NST04) to span between the header tank and bottom of the radiator.

From the 'HGW Models' Sopwith Triplane detail set (132099), use parts 6 and 7 to create a cable pulley, using CA adhesive

Chemically blacken the pulley assembly by dipping in, for example, 'Blacken-It'.

Prime the radiator assembly with 'Alclad' Gloss Black primer (ALC-305) and once dry, with Duraluminium (AL-102). Then a light 'dusting' of Gold (ALC-108). Once dry lightly buff the surface to allow the Duraluminium to show through in patches.

Cut out the two radiator photo-etch grills (A34, A43) from the 'RB Productions' Fokker D.VII radiators (RB-P32031). The grills required are the same part numbers as the kit parts.

Carefully bend the grills at the 'fold' lines until they conform to the shape of the radiator.

Secure the grills (one at a time) onto the radiator assembly using PVA adhesive. Clamp each grill in position until the adhesive has set. CA adhesive (thin) can be used but care is needed when locating the parts as CA adhesive is an instant bond.

Brush paint the filler cap (A31) using 'Mr. Colour' Brass (219) and coolant pipe 'Tamiya' Rubber Black (XF85).

Using the drawing as reference, position the 0.4 mm tube and flap against the rear right of the radiator assembly. Note the position of the flap to the tube.

Secure the tube to the left edge of the flap using CA adhesive.

Cement the 'web' to the rear face of the flap.

Prime the flap assembly with 'Alclad' Gloss Black primer (ALC-305) and once dry, with Duraluminium (AL-102).

Locate the flap assembly onto the rear of the radiator and secure in position using CA adhesive.

Weather the radiator photo-etch using 'AK Interactive' Kerosene wash (AK 2039) thinned with White Spirit.



Prime the dual coolant pipe (B19) with 'AK Interactive' primer and micro filler (Grey AK-758) and once dry, with 'Tamiya' Rubber Black (XF85).

Cement the coolant pipe to the two pipe locations at the bottom of the radiator.

Locate the top rear location stub on the radiator into the hole in the first cylinder and locate the coolant pipe against the engine driven water pump.

Secure the radiator connection with CA adhesive and the cement the pipe connection.

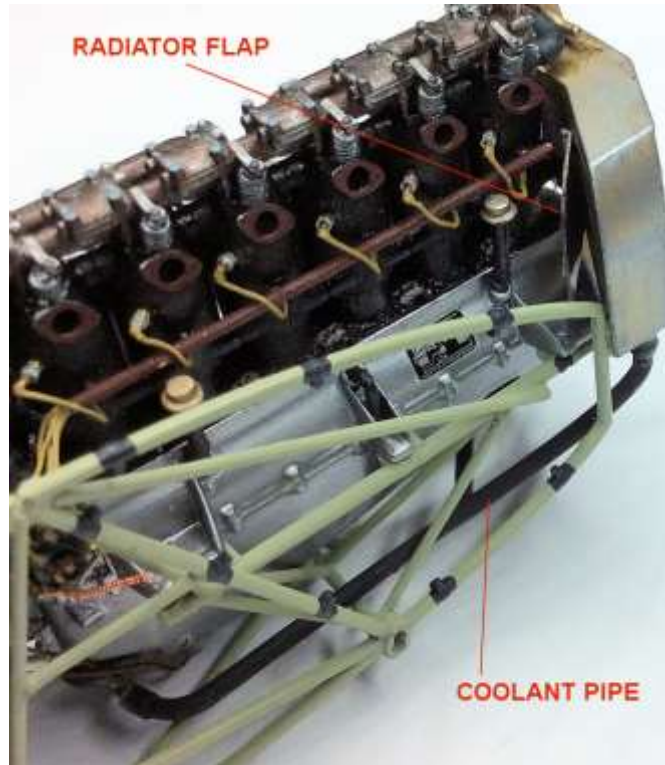

78. Radiator flap control:

Cut a long length of 'Albion Alloys' 0.4 mm diameter Nickel-Silver tube (NST04).

Cut a length of 'Albion Alloys' 0.1 mm diameter Nickel-Silver rod (NSR01).

Cut a short length of 0.125 mm diameter copper wire.

Slide the 0.1 mm rod into the 0.4 mm tube and secure using CA adhesive.

Slide the created photo-etch pulley onto the 0.4 mm and position it just before the 0.1 mm rod. Secure it in position using CA adhesive.

At the pulley, bend the 0.1 mm rod up to approximately 30 degrees.

Chemically blacken the control assembly by dipping it in, for example, 'Blacken-It' or brush paint 'Tamiya' Rubber Black (XF85).

Lay the control on the right side fuselage with the pulley vertical and close to the centre engine mounting. Bend the cockpit end of the 0.4 mm tube up so that it is parallel with the hand operated pressure pump then trim the tube so the end is just proud of the instrument panel.

Insert the 0.125 mm copper wire into the 0.4 mm tube at the cockpit end and bend it into a small loop then secure with CA adhesive.

Brush paint the loop with 'Tamiya' Red (XF7).

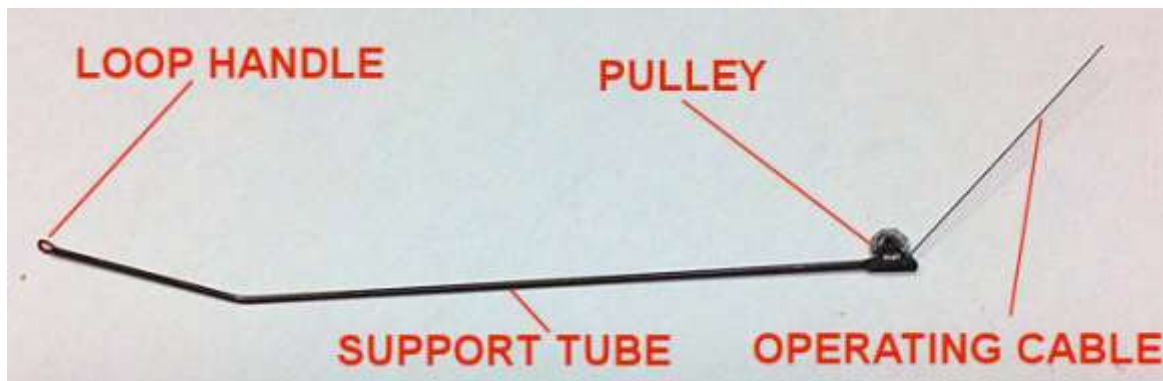

Carefully pass the control through the fuselage side frame to position the pulley vertical and on the engine bearer just to the rear of the engine centre mounting, with the cockpit end of the tube parallel with the pressure pump.

Secure the control in position using CA adhesive.

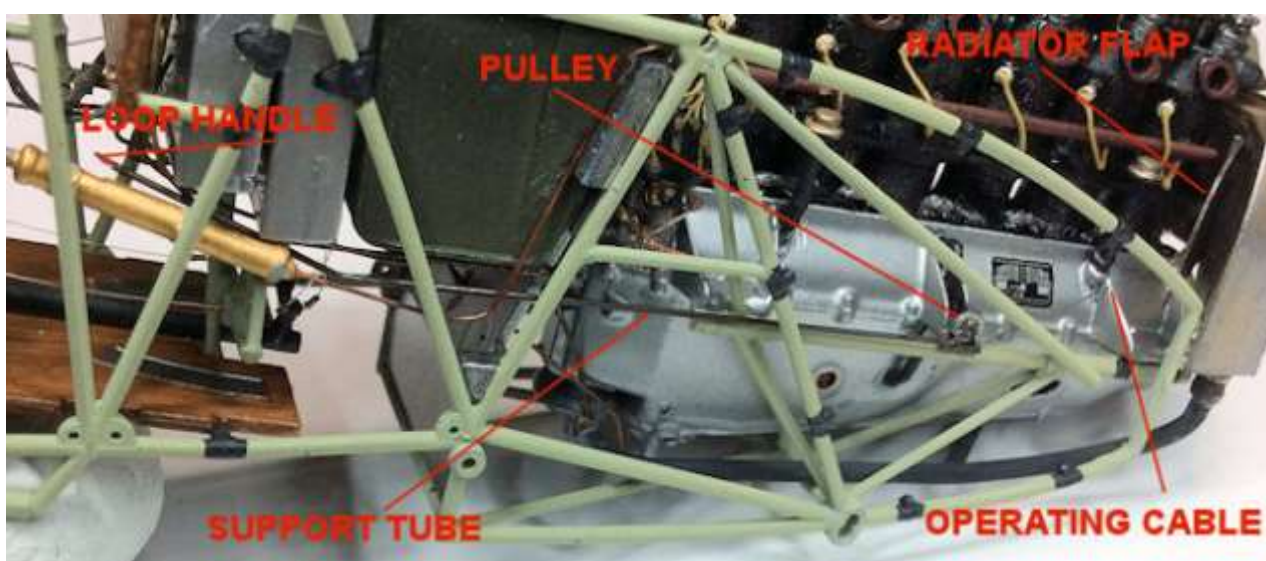

79. Radiator side stays:

The radiator was supported on each side by a 'stay' rod, which was attached to the radiator side and to the fuselage side frame.

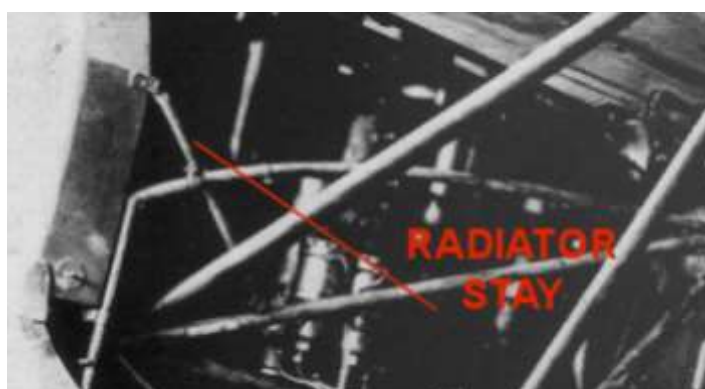

Cut two lengths of 'Albion Alloys' 0.5 mm diameter brass tube (MBT05) such that they fit between the radiator sides and the fuselage side frames (refer to the photograph above).

Brush prime then paint the two tubes using 'Tamiya' Grey Green (XF76).

Locate the two tubes in position and secure to the fuselage frame using CA adhesive.



80. Brush paint the fuselage frame clamps with 'Tamiya' Rubber Black (XF85) and once dry, the central clamp bands with 'Mr. Colour' Stainless Steel (213).
 81. Airbrush the fuselage frame and cockpit with either 'Alclad' Light Sheen (ALC-311) lacquer or 'Tamiya' Semi Gloss (X35).
- Note:** For the following steps refer to Part 3 of this build log.
82. If desired, apply the 'Flory' clay wash of your choice, such as Dark Dirt.
 83. Seal the weathering by airbrushing with 'Alclad' Semi-Matt (ALC-312).
 84. If desired, apply other staining effects by using 'MiG' oil brushers or 'Abteilung' oils, then blending with a brush very lightly dampened with enamel thinners.
 85. Fuel and oil stains can also be applied using 'AK Interactive' washes, such as engine oil (AK 2019), kerosene (AK 2039) or engine wash (AK2033).

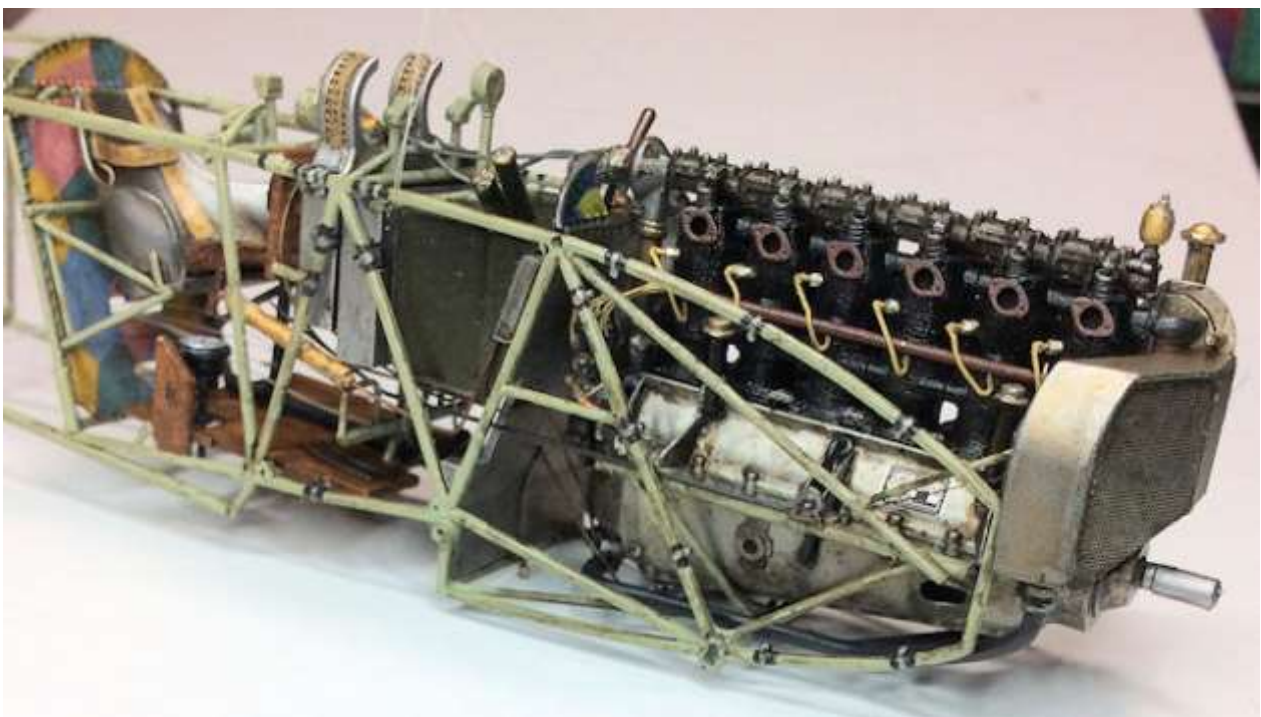

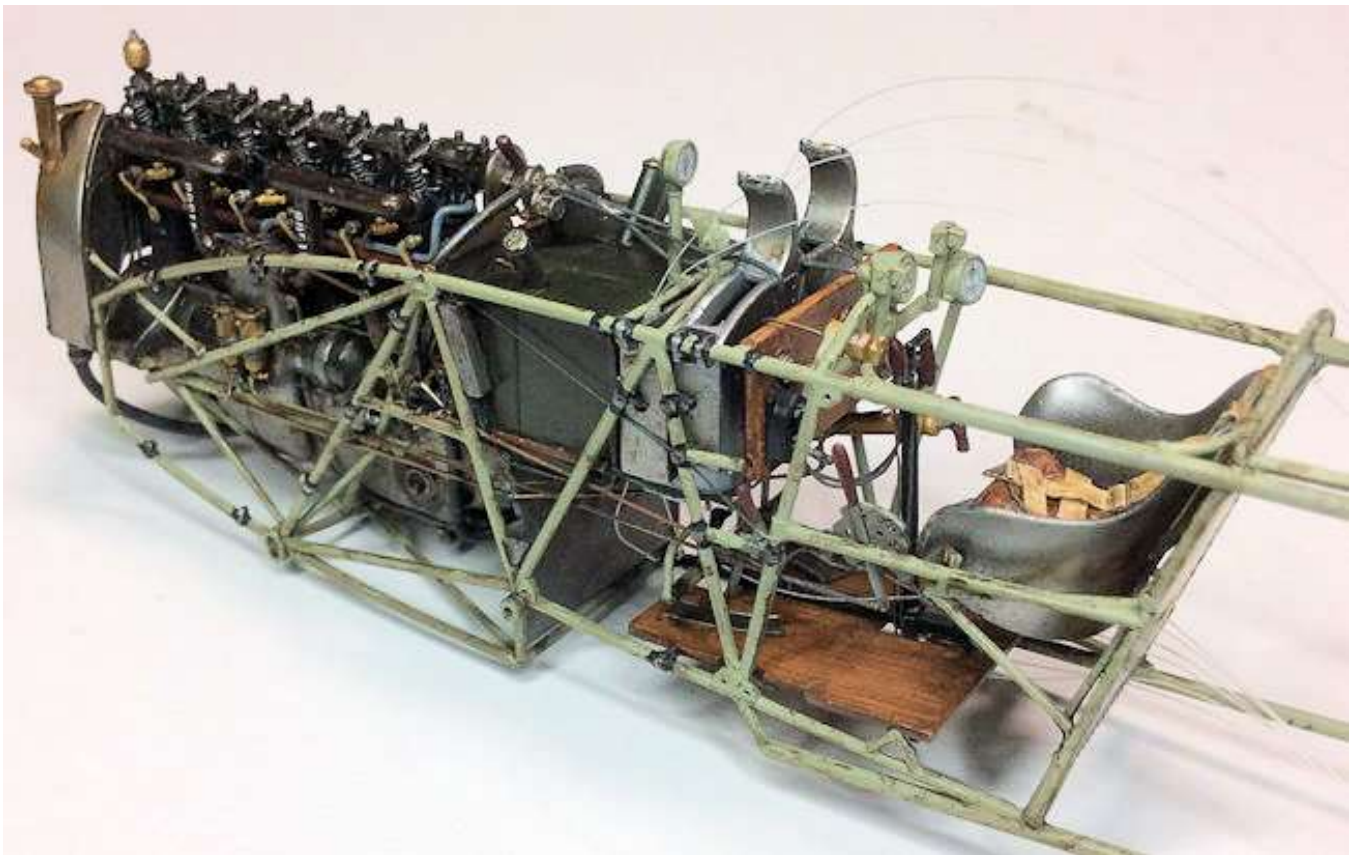
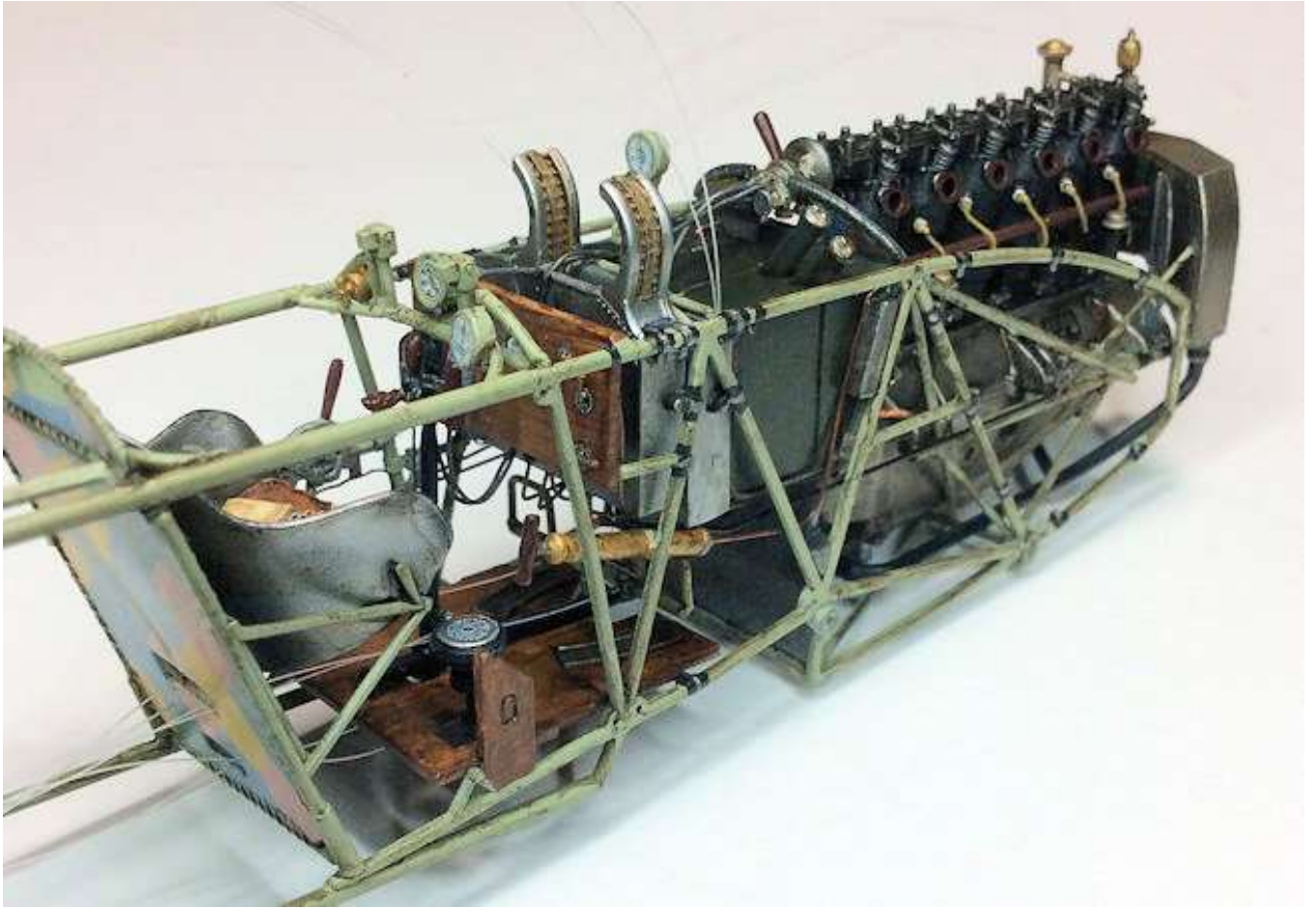

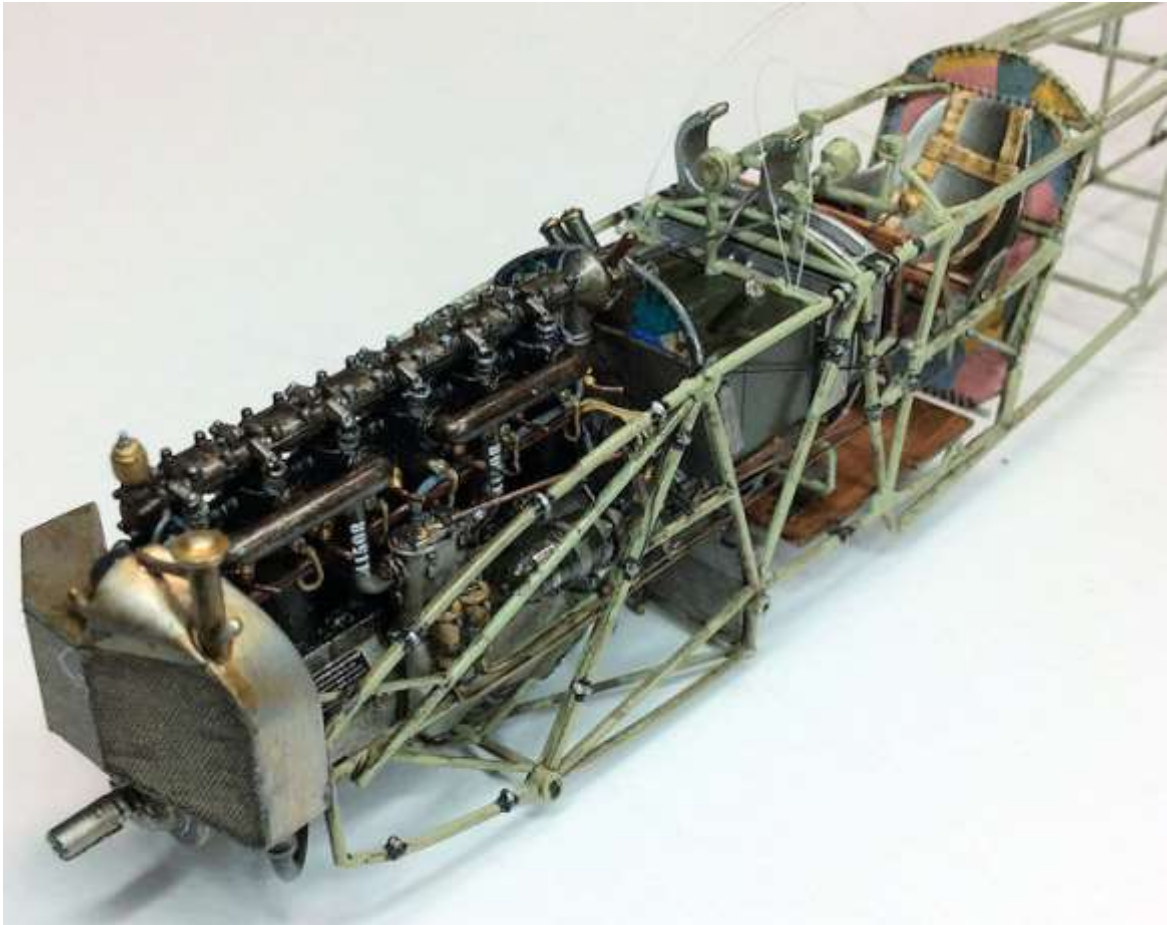

86. Rigging forward cockpit area:

The tubular frame work of the fuselage, although light in weight, was in itself not strong enough to withstand the torsion and loads applied to it during operational use. Therefore double bracing wires were used:

1. Across the top of the fuel tank.
2. Across the fuselage frame below the pilots seat.
3. Between the frame bays next to the pilots seat.
4. Across the rear face of the pilots seat frame.
5. Between the vertical fuselage frame bays rear of the pilot.
6. Across the top of the four fuselage frame bays rear of the pilot.
7. Across both sides of the four fuselage frame bays rear of the pilot.
8. Across the bottom of the four fuselage frame bays rear of the pilot.

To create a single, initial cross brace cable:

Cut a long length of 'Stroff' mono-filament (0.08 mm diameter).

Cut two short lengths of 'Albion Alloys' 0.4 mm Nickel-Silver tube (NST04).

Prepare one 'Gaspatch' 1/48th scale turnbuckle (Type C) by breaking it off the base and filing the tag away (diamond file).

Thread the mono-filament through a cut tube then through an 'eye' end of the turnbuckle.

Loop the mono-filament back through the cut tube.

Slide the tube up to but not touching the turnbuckle 'eye' end.

Keeping the turnbuckle and mono-filament inline, secure the tube in position using CA adhesive.

Paint the body of the turnbuckle with a 50/50 mix of 'Tamiya' Copper (XF6) and Hull Red (XF9).



Across the top of the fuel tank:

Drill a 0.2 mm diameter hole, horizontally through the four corners of the top side frame tubes.

Thread a bracing cable through one corner hole then diagonally across and through the opposite hole.

Loop the cable over that tube and back across to the original corner.

Slide a cut 0.4 mm diameter tube onto the cable then pass the end of the cable through the remaining 'eye' end of the turnbuckle.

Pass the end of the cable through the 0.4 mm tube then carefully pull the free end to tighten the dual wires.

Make sure the turnbuckle assembly is clear of the fuselage side frame top tubes and close to the forward corner.

Secure the tube to the cable and at both corners using CA adhesive.

Carefully trim away the exposed free end of the cable.

Repeat this procedure across the remaining two corners to create dual and crossed bracing wires.

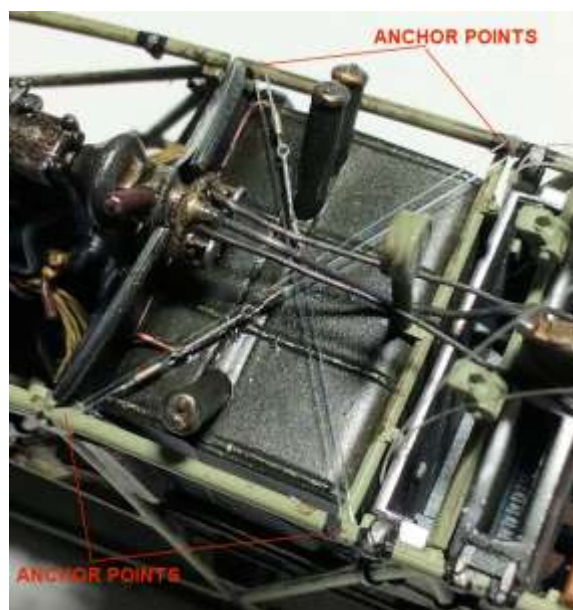

Across the fuselage frame below the pilots seat:

NOTE: *This cross bracing consists of double bracing crossing the underfloor and also double bracing crossing in the same area, but from the bottom of the fuselage side frames.*

Thread a bracing cable through one pre-molded corner hole at the bottom, forward end of the side frame next to the pilots seat.

Pass the cable diagonally across and around the base of the opposite vertical tube of the pilots seat frame.

Pass the cable back across to the starting point.

Slide a cut 0.4 mm diameter tube onto the cable then pass the end of the cable through the remaining 'eye' end of the turnbuckle.

Pass the end of the cable through the 0.4 mm tube then carefully pull the free end to tighten the dual cables.

Make sure the turnbuckle assembly is clear of the fuselage side frame and close to the forward corner.

Secure the cable in place at both corners using CA adhesive.

Carefully trim away the exposed free end of the cable.

Repeat this procedure across the remaining two corners to create dual and crossed bracing cables.

At the bottom, forward corner of the fuselage side frames, drill a 0.2 mm diameter hole, horizontally through the frame.

Repeat the procedure as before to create dual and crossed bracing cables above those previously created.

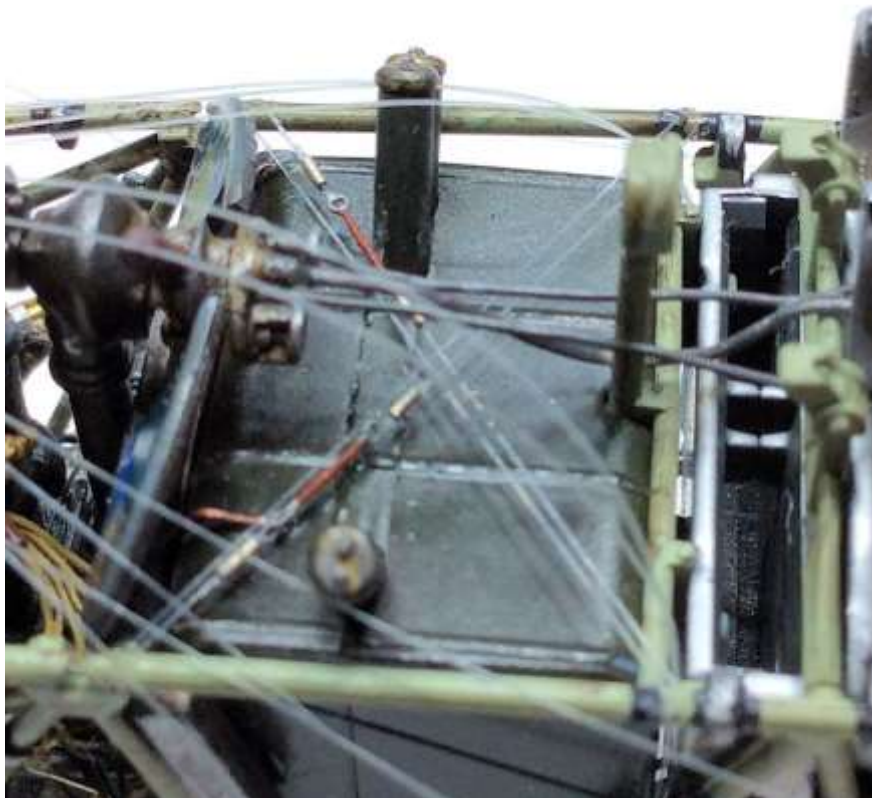

Across the rear face of the pilots seat frame:

NOTE: *The 3D printed fuselage frame has been joined to the kit frame using brass tube. This required the removal of frame detail, which means there are no anchor points for the bracing cables behind the pilot's seat support frame.*

Drill a hole of 0.3 mm diameter horizontally through the four fuselage longerons, close behind the pilot's seat support frame.

Thread a bracing cable through one pre-drilled in a bottom longeron.

Pass the cable diagonally up and through the pre-drilled hole in the opposite top longeron.

Pass the cable back across to the starting point.

Slide a cut 0.4 mm diameter tube onto the cable then pass the end of the cable through the remaining 'eye' end of the turnbuckle.

Pass the end of the cable through the 0.4 mm tube then carefully pull the free end to tighten the dual cables.

Make sure the turnbuckle assembly is clear of the fuselage side frame.

Secure the tube to the cable using CA adhesive.

Carefully trim away the exposed free end of the cable.

Repeat this procedure across the other corners to create double crossed bracing cables behind the pilot's seat support frame.



Between the frame bays next to the pilots seat:

Thread a bracing cable through one pre-molded corner hole at the bottom, forward end of the side frame next to the pilots seat (used already for the under floor cross bracing).

Pass the cable diagonally up and around the top of the vertical tube of the pilot's seat frame.

Pass the cable back across to the starting point.

Slide a cut 0.4 mm diameter tube onto the cable then pass the end of the cable through the remaining 'eye' end of the turnbuckle.

Pass the end of the cable through the 0.4 mm tube then carefully pull the free end to tighten the dual cables.

Make sure the turnbuckle assembly is clear of the fuselage side frame and close to the forward corner.

Secure the tube to the cable using CA adhesive.

Carefully trim away the exposed free end of the cable.

Repeat this procedure across the other corners then carry out the same to the side frame on the other side of the pilot's seat.



Between the vertical fuselage frame bays rear of the pilot:

NOTE: *The 3D printed fuselage frame has anchors for bracing cables in the form of 'hoops' molded into the corners of the vertical frames.*

Thread a bracing cable through one bottom longeron 'hoop' at the first vertical frame rear of the pilot's seat support frame.

Pass the cable diagonally up and through the opposite 'hoop' in the opposite top longeron.

Pass the cable back across to the starting point.

Slide a cut 0.4 mm diameter tube onto the cable then pass the end of the cable through the remaining 'eye' end of the turnbuckle.

Pass the end of the cable through the 0.4 mm tube then carefully pull the free end to tighten the dual cables.

Make sure the turnbuckle assembly is clear of the 'hoop'.

Secure the tube to the cable using CA adhesive.

Carefully trim away the exposed free end of the cable.

Repeat this procedure across the other corner 'hoops' to create double crossed bracing cables between the vertical frame.

Moving rearwards, repeat this procedure for the remaining four vertical fuselage frames.

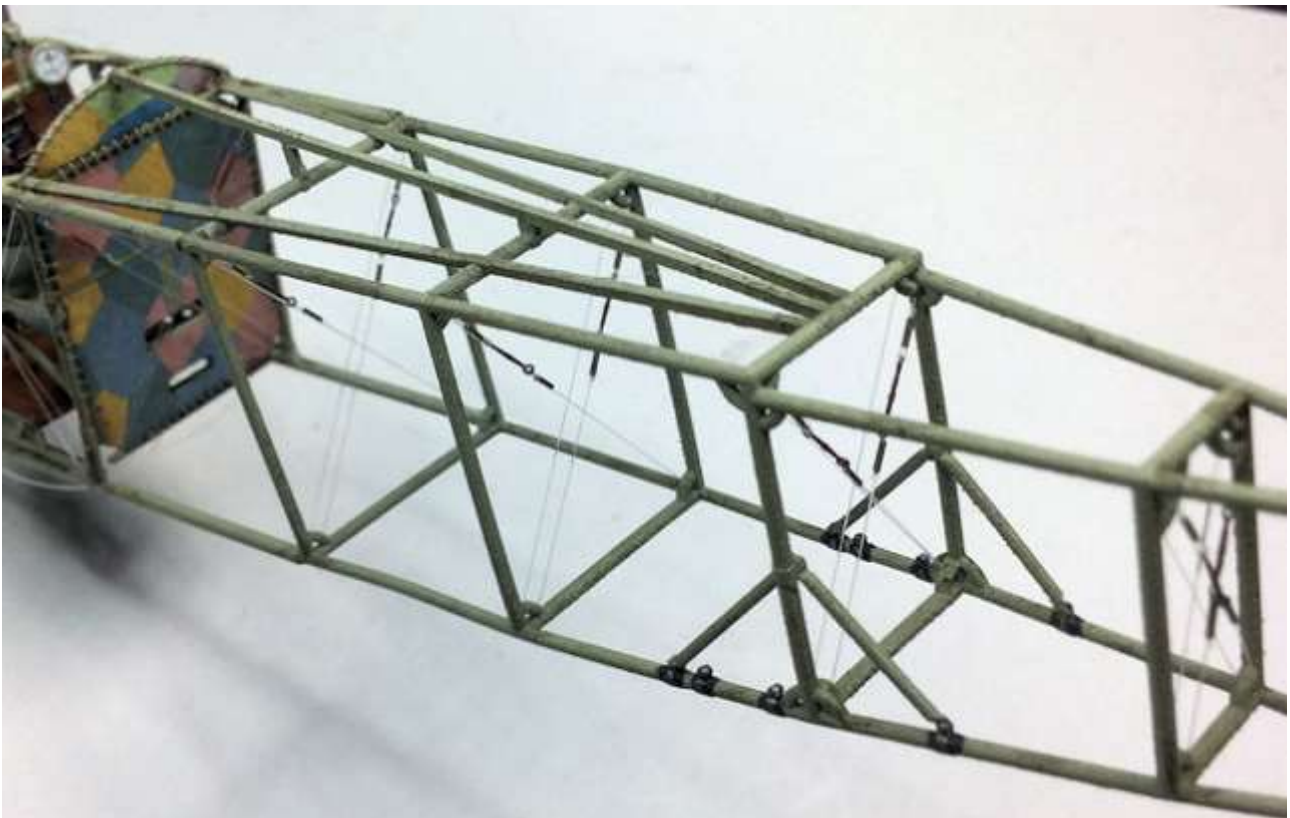

Across the top of the four fuselage frame bays rear of the pilot:

Thread a bracing cable through the corner gap at the top of the pilot's seat support frame.

Pass the cable diagonally across to the corner of the opposite top longeron.

Loop the cable over the longeron then back across to the starting point.

Slide a cut 0.4 mm diameter tube onto the cable then pass the end of the cable through the remaining 'eye' end of the turnbuckle.

Pass the end of the cable through the 0.4 mm tube then carefully pull the free end to tighten the dual cables.

Make sure the turnbuckle assembly is clear of the pilot's seat support frame.

Secure the tube to the cable using CA adhesive.

Carefully trim away the exposed free end of the cable.

Repeat this procedure across the other corners to create double crossed bracing cables behind the pilot's seat support frame.

Working rearwards, repeat this procedure to the next three bays, but using the pre-molded 'loops' in the corners of the 3D printed fuselage bays, to create their dual cross bracing cables.

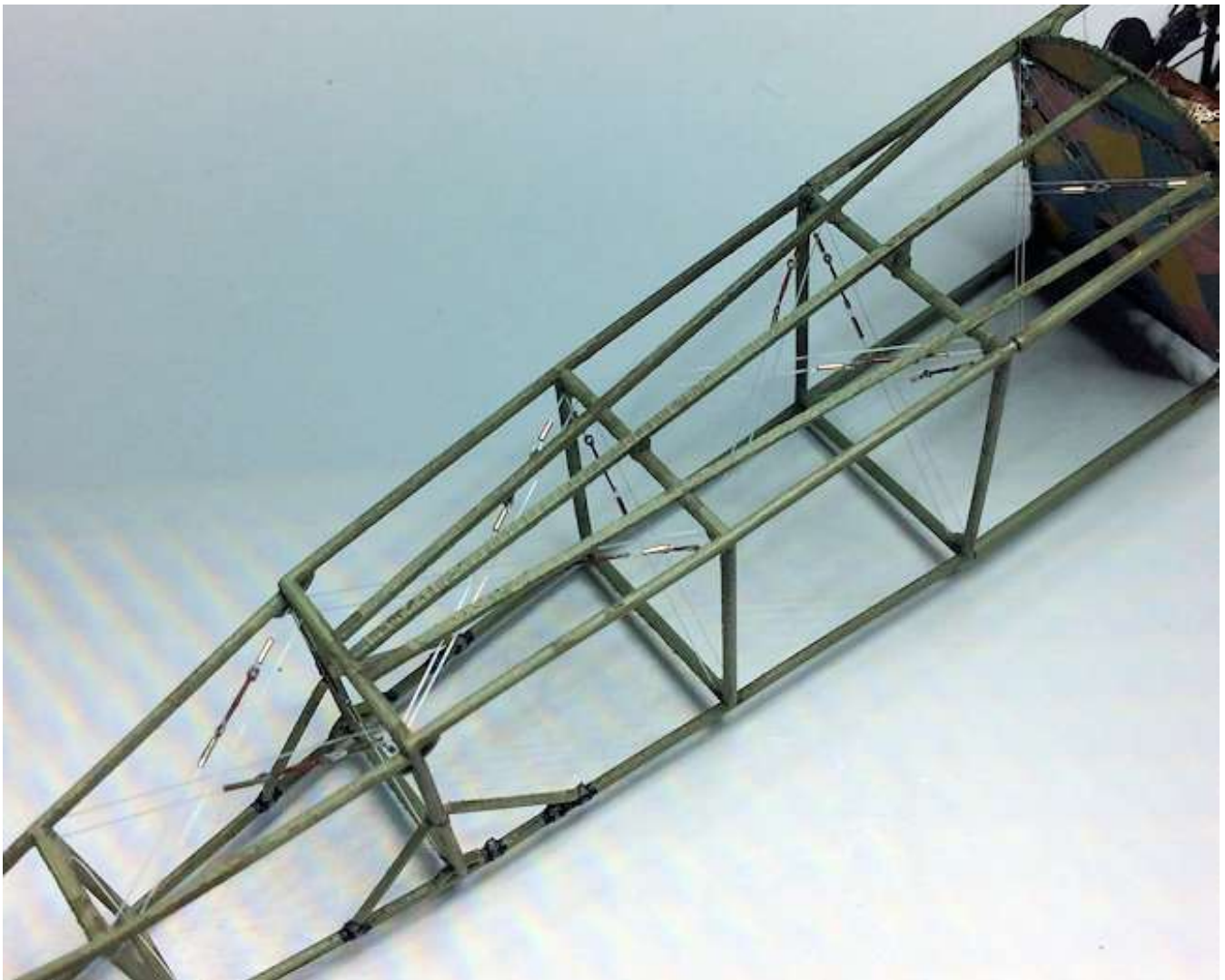

Across both sides of the four fuselage frame bays rear of the pilot:

NOTE: *This stage of rigging will require twenty lengths of rigging cables.*

Starting on one side of the fuselage, thread a bracing cable through or around the corner gap at the top of the pilot's seat support frame.

Pass the cable rearwards and diagonally across to the 'loop' in the corner of the next vertical frame.

Loop the cable through the 'loop' then back across to the starting point.

Slide a cut 0.4 mm diameter tube onto the cable then pass the end of the cable through the remaining 'eye' end of the turnbuckle.

Pass the end of the cable through the 0.4 mm tube then carefully pull the free end to tighten the dual cables.

Make sure the turnbuckle assembly is clear of the pilot's seat support frame.

Secure the tube to the cable using CA adhesive.

Carefully trim away the exposed free end of the cable.

Repeat this procedure across the other corners to create double crossed bracing cables in the frame behind the pilot's seat support frame.

Working rearwards, repeat this procedure to the next four frame bays, using the pre-molded 'loops' in the corners of the 3D printed fuselage bays, to create their dual cross bracing cables.

Repeat this procedure on the opposite side of the fuselage to create its cross braced frames.

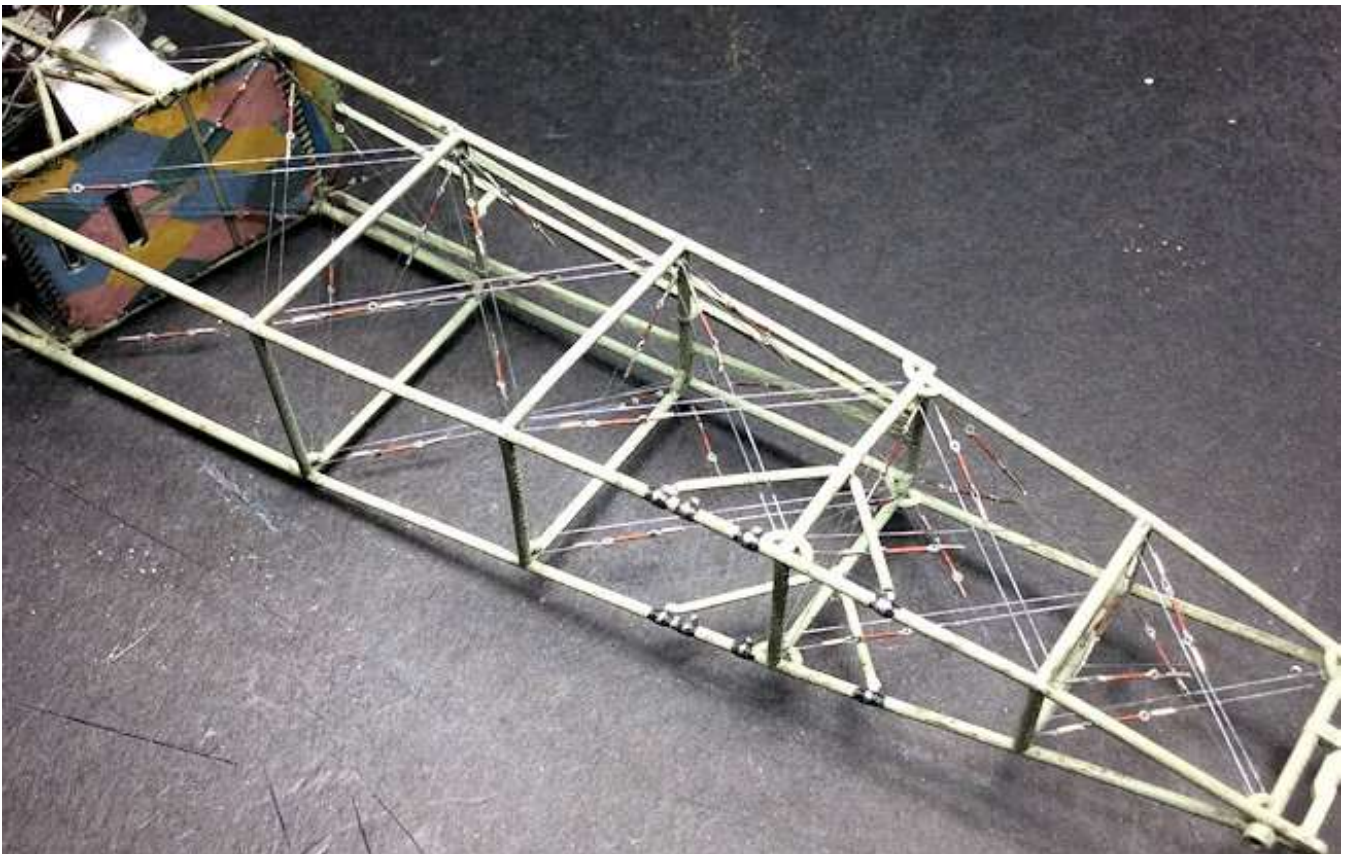

87. Rear decking panel:

NOTE: *At this stage the fuselage top rear decking panel should be fitted. Access underneath for fitting the decking would be restricted if the bottom cross brace cables are already fitted.*

The top of the fuselage, rear of the cockpit, was covered by a 3-ply, tapered panel, which extended back to the forward edge of the tail plane. The panel was secured to three longerons on the top of the fuselage frame.

NOTE: *On the modified 3D printed fuselage, the three centre support longerons for supporting the fuselage top decking panel protrude from the sides of the arched top of the pilot's seat support frame. The created decking panel should lay over the arched top of the seat frame then extend forwards past the arch and then half way along the cockpit side frames. The longeron protrusions prevent a smooth transition, leaving a 'bulge' at each side of the decking panel. To overcome this the seat frame and fuselage longerons needed to be modified.*

Using a sharp cutter, cut away 5 mm from the front of each of the three support longerons, leaving a gap between them and the rear of the pilot's seat support frame.

Keeping the curved shape, file or sand away the top of the arch on the pilot's seat support frame until a sheet of 0.2 mm thick plastic card will lay on the three support longerons, over the seat frame arch and lay on the top of the cockpit side frames.

Using a sheet of paper, cut out a template for the panel, which should lay on the three support longerons, over the seat frame arch and then lay on the top of the cockpit side frames. The edges of the panel should also align with the edges of the two outer support longerons.

Trace the outline of the paper template onto a sheet of 0.2 mm thick plastic card.

Cut out the shape from the plastic card and then test fit the panel.

Airbrush both sides of the panel using primer (Grey - AK 758) then once dry, with 'Tamiya' Deck Tan (XF78).

Apply your desired wood effect (refer to Part 2 of this build log) - I used 'DecoArt' Burnt Sienna acrylic oil paint.

Apply CA adhesive along the top of the centre support longeron and the arch on the pilot's seat support frame.

Position the panel onto the centre support longeron and the arch of the seat support frame, making sure to align the rear edge with the end of the three support longerons and the tops of the cockpit side frames.

If necessary, reinforce the glued joint by applying more CA adhesive along the centre longeron from underneath.

Once fully set, carefully press one side edge of the panel against its support longeron then secure in position using CA adhesive.

If necessary, reinforce the glued joint by applying more CA adhesive along the longerons from underneath.

Once fully set, carefully press the remaining side edge of the panel against its support longeron then secure in position using CA adhesive.

If necessary, reinforce the glued joint by applying more CA adhesive along the centre longeron from underneath.

Locate in position the decking panel over the sides of the arch on the pilot's seat support frame and half way along the top of the cockpit side frames, then secure in position using CA adhesive .



88. Tail skid assembly:

NOTE: *The 3D printed parts include the tail skid, which will need to be modified to replicate its mounting in the aircraft. These modifications to the tail skid also need to be able to take the weight of the model.*

The tail skid fitted to the Fokker D.VII was not of the steerable type. The skid was attached to the rear fuselage post and was able to flex with the weight of the aircraft, The top of the tail skid was anchored to the top corners of the fuselage rear bay frame by two springs and a bungee type cord. This arrangement allowed the tail skid to pitch forwards and rearwards with the weight of the aircraft on the ground.

Preparation:

Clear out the location hole in the bottom rear of the 3D printed fuselage for locating the post of the tail skid. Use a 0.8 mm diameter drill.

Clear out the hole in the small lug on the top of the 3D printed tail skid, using a drill of 0.5 mm diameter.

Airbrush prime the tail skid using Grey (AK-758).

Airbrush the tail skid using 'Tamiya' Deck Tan (XF78).

Apply your desired wood effect (refer to Part 2 of this build log) - I used 'DecoArt' Burnt Sienna.

Brush paint the steel fittings on the tail skid using 'Mr. Colour' Stainless Steel (213).

Suspension springs:

Cut two strands of 0.125 mm diameter copper cable.

Bend each cable to form a double strand then holding the bent end, twist the two strands together to form a continuous 'helix' (to create the suspension springs).

At the open ends of the 'helix', cut away one strand of cable to leave one strand. This will be used to anchor the 'spring' to the fuselage frame.

Brush paint the 'springs' using 'Mr. Colour' Stainless Steel (213).

Locate the spigot on the tail skid into the hole in the bottom rear of the fuselage. Ensure the spigot is fully located into the fuselage and that the top end is clear of any cross brace rigging. Secure in position using CA adhesive.

Carefully locate the wound end of one of copper cable 'springs' into the 0.5 mm hole in the small lug at the top of the tail skid. Check that the single strand of cable is able to pass through the 'hoop' in the top corner of the fuselage frame.

Note how much of the 'spring' protrudes from the underside of the lug. Remove and trim its length as required.

Finally position the 'spring' into the lug and the single cable through the frame corner 'hoop'.

Repeat this to create a 'spring' for the other side of the tail skid.

Retainer cable:

Cut a short length of 'Model Factory Hits (MFH)' Black Colour Tube (P-961).

Cut a long length of 0.2 mm diameter 'PlusModel' lead wire.

Pass the lead wire through the cut 'MFH' tube to the centre of the lead wire.

With the 'MFH' tube at the top of the fuselage frame (above the tail skid), carefully thread the left and right lead wire:

Through their 'hoops' in the top corners of the fuselage frame.

Loop the cables down to where the suspension springs are attached to the tail skid lug.

Pass the cables across the junction where the two springs enter the lug on the tail skid.

Trim the end of the cables to finish at the base of the two springs.

Secure the lead wire in position, with CA adhesive:

In the corner 'hoops' of the fuselage frame.

At the lug on the tail skid.

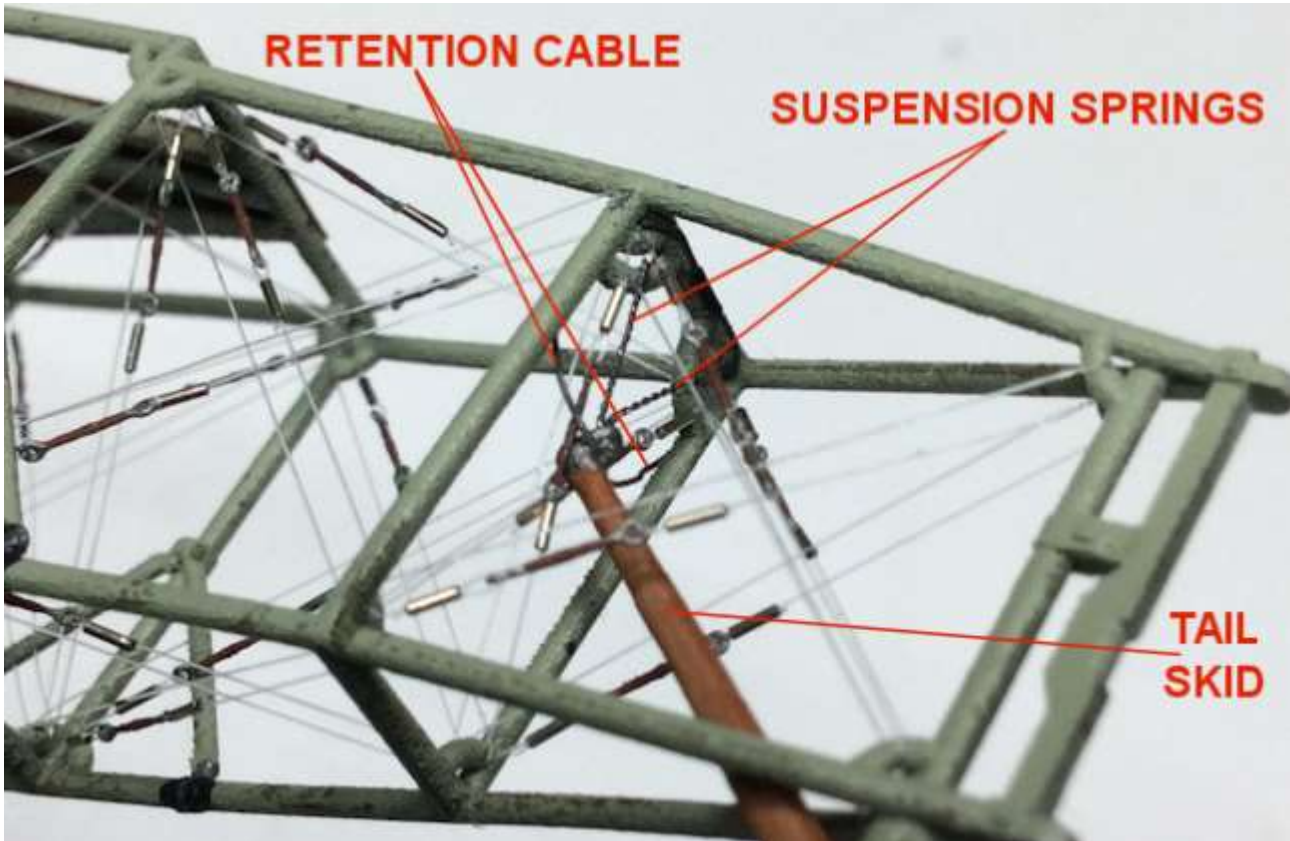

89. Across the bottom of the four fuselage frame bays rear of the pilot:

Thread a bracing cable through the corner gap at the bottom of the pilot's seat support frame.

Pass the cable diagonally across to the corner of the opposite top longeron.

Pass the cable through the frame 'hoop' then back across to the starting point.

Slide a cut 0.4 mm diameter tube onto the cable then pass the end of the cable through the remaining 'eye' end of the turnbuckle.

Pass the end of the cable through the 0.4 mm tube then carefully pull the free end to tighten the dual cables.

Make sure the turnbuckle assembly is clear of the pilot's seat support frame.

Secure the tube to the cable using CA adhesive.

Carefully trim away the exposed free end of the cable.

Repeat this procedure across the other corners to create double crossed bracing cables behind the pilot's seat support frame.

Working rearwards, repeat this procedure to the next three bays, but using the pre-molded 'loops' in the corners of the 3D printed fuselage bays, to create their dual cross bracing cables.

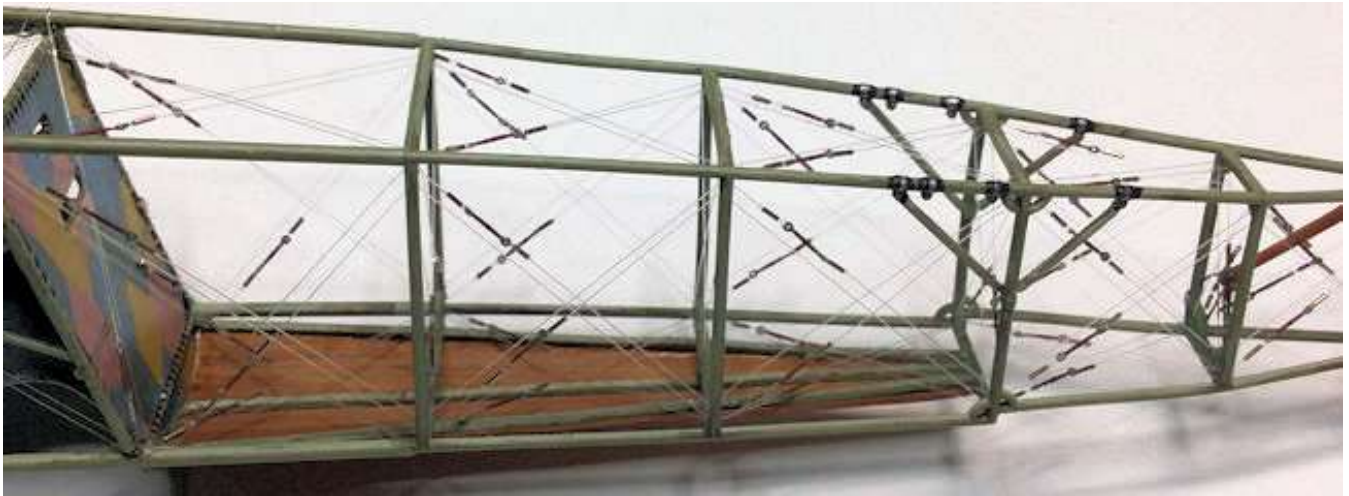

90. Cockpit surround padding:

The edge of the cockpit was padded with a leather covered 'rim', which was fitted all around the cockpit opening. As this model does not have the cockpits forward decking panel fitted, the padding can only be replicated on the rear of the cockpit opening.

Cut a length of 2 mm diameter clear plastic tube, sufficient to fit around the front edge of the fuselage top decking and onto the top of the cockpit side frames.

Insert a length of 1.2 mm diameter tube or rod through the tube.

Lightly scuff the surface of the plastic tube to prepare it for painting.

Using a sharp blade, carefully slice along one side of the plastic tube, keeping central along the tube.

Remove the 1.2 mm tube or rod.

Carefully locate the slit in the plastic tube over the forward edge of the fuselage decking panel and onto the top of the cockpit side frames.

Secure in position using CA adhesive.

Using a sharp straight edge scalpel blade, carefully trim away any excess of the tube to create an even surround.

Brush prime the plastic tube using Grey-758.

Brush paint the tube with 'Humbrol' Leather (62) with highlights of 'Tamiya' Hull Red (XF9).

Airbrush several light coats of Alclad Light Sheen (ALC-311) lacquer over the padding and fuselage decking panel.

Refer to Part 3 of this build log - Apply the Flory clay wash (Dark Dirt) over the padding and fuselage decking panel.

Airbrush a sealing coat of Alclad Light Sheen (ALC-311) lacquer over the padding and fuselage decking panel.



91. Weapons:

This aircraft was fitted with two synchronized Spandau LMG 08/15 machine guns, which were belt fed from an ammunition box, located below the guns. The guns supplied with the kit are solid and do not represent the open structure of the guns cooling jacket and barrel.

Therefore I decided to replace them with the 'Gaspatch' Spandau 08/15 extended loading handle (18-32128), which have finely cast detail, but need to be handled very carefully as resin is brittle and therefore easy to break if handled roughly. As the ammunition belts and feed chutes for the two machine guns are supplied with the kit, these items from the 'GasPatch' set were not used.



Machine guns:

NOTE 1: The two 'GasPatch' replacement machine guns must be test fitted to align correctly to the kit mountings etc. Some minor modifications will be required to achieve this.

NOTE 2: The 'GasPatch' machine guns can easily be damaged or broken during handling, so care needs to be taken, especially with the perforated cooling jackets and where they attach to the breech block.

Insert the 'GasPatch' gun barrel through the hole in the front of the gun cooling jacket so the barrel end locates in the breech block and the anti-flash muzzle is located in the cooling jacket. Secure in position using CA adhesive.

Carefully cut away the 'swing link' from the forward gun mounting.

Carefully file a step in the bottom, rear of the breech block (compare to the kit supplied weapon).

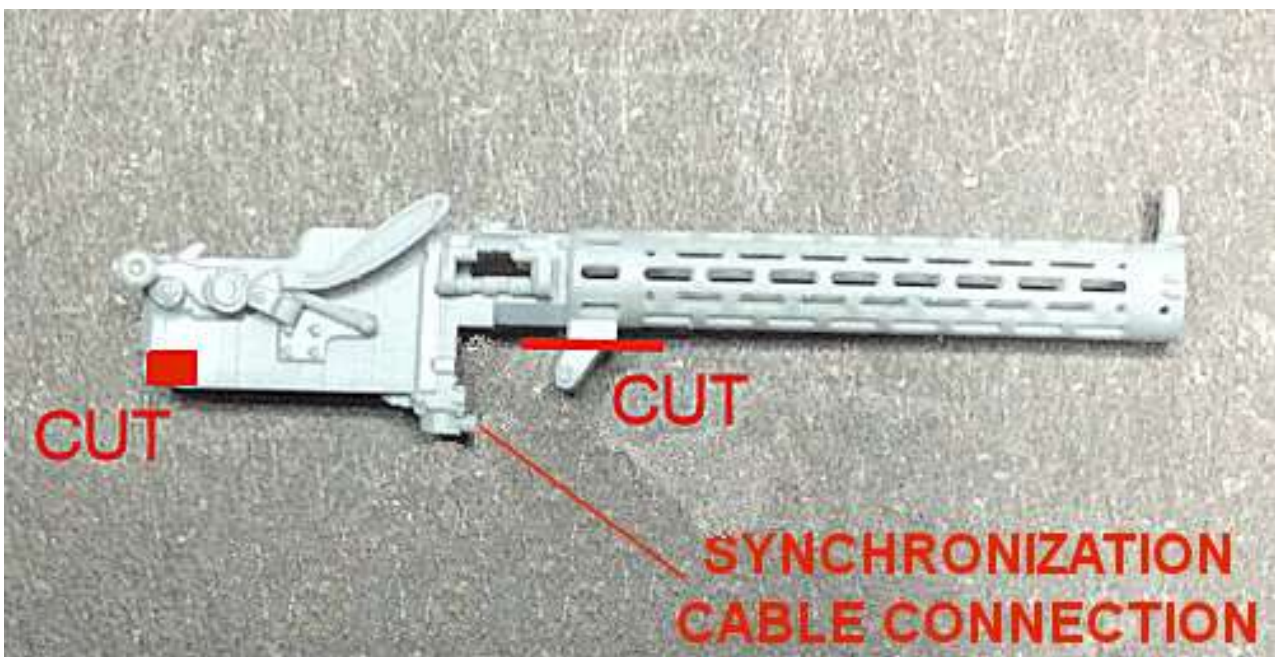

Test 'dry' fit each modified machine gun, making sure the cut front mountings align with the install kit mounts and the breech 'step' locates over the installed kit rear mount. Each machine gun should be horizontal (not tipped front or rear).

Locate the head protection pads onto the end of the breech blocks, making sure they are fitted the correct way (flush with the top of the breech block) and then secure in position using CA adhesive.

NOTE: The kit supplied ejection chute A12 is shorter than chute A13, as it is intended to fit into the left side of the cockpit forward decking panel, which is not being used on this build. Consequently it is too short to enter the left side of the exposed empty rounds container when attached to the left guns breech block. This part was replaced with another A13 ejection chute.

Airbrush prime the gun assemblies and the ammunition ejector chutes (A13) using Grey (AK-758).

Airbrush the guns using 'Alclad' Gun Metal (ALC-120).

Airbrush the guns with a light, misting coat, using 'Alclad' Steel (ALC-112).

Airbrush the two ejector chutes using 'Alclad' Steel (ALC-112).

Brush paint the ammunition belt entry and exit ports with a mix of 'Mr. Colour' Brass (219) and Copper (215).

Dry brush around the muzzle with 'Tamiya' Rubber Black (XF85).

Paint the head protectors with 'Humbrol' leather (62) with a small amount of 'Tamiya' Hull Red (XF9).



Flash guards:

The engine valve gear was protected from the muzzle flash and ammunition fired from the two machine guns by a set of 'flash guards'. These were essentially metal 'troughs' that were joined by cross members fitted to the engine camshaft covers. The guards were located on the top of the engine and below the line of fire from the two guns.

Position the two flash guard rails (kit part D7) onto the photo-etch support (P3) and secure in position using CA adhesive.

Airbrush prime the assembly using Grey (AK-758).

Airbrush the assembly using 'Alclad' Gun Metal (ALC-120).

Airbrush the assembly with a light, misting coat, using 'Alclad' Steel (ALC-112).

Dry brush along the rails with 'Tamiya' Rubber Black (XF85).



Synchronization cables:

The two machine guns were synchronized with the rotating propeller so that ammunition rounds stopped firing when the propeller blades were in front of the gun nozzles. Each machine gun firing was controlled by a flexible drive that was connected between the bottom of the guns breech block and the gun synchronization mechanism ('*Zentralsteuerung*'), located at the top, rear of the engine. The trigger cable on the control column operated the mechanism. using lead wire. These flexible drives will be represented by using 0.5 mm diameter lead wire.

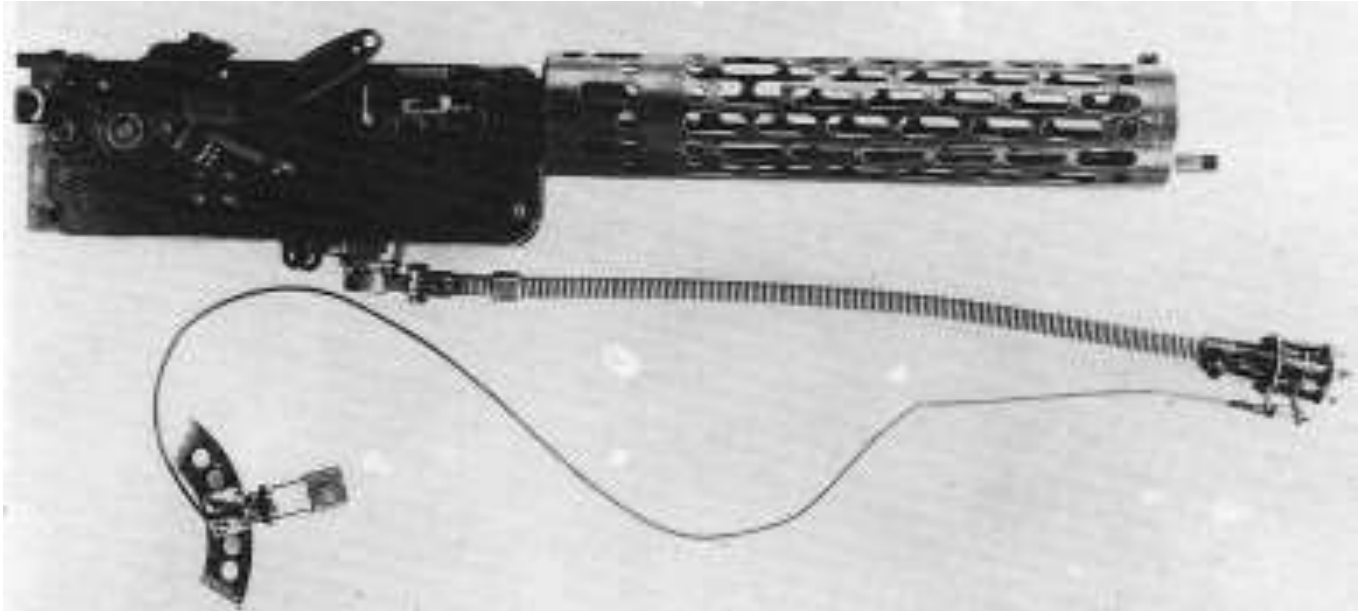

Assembly:

Position each machine gun onto its front and rear gun mountings and also against its ammunition feed chute. Make sure the gun sits vertical on the gun mounts and is horizontal to the fuselage line (not tipped up or down at the front or rear).

Secure the guns in position using CA adhesive on the gun mounts and at the joint of the breech block to ammunition feed chute.

NOTE: *The flash guard assembly has three cross members, each with two holes. These holes locate onto the studs of the engine cam shaft covers. Refer to the 'Wingnut Wings' instruction manual for the location points.*

Locate the flash guard assembly onto the studs of the engine camshaft covers and secure in position using CA adhesive.

Carefully bend the photo-etch cross members to position the two rails below the muzzles of the two machine guns.

Cut a long length of 'PlusModel' 0.5 mm diameter lead wire.

Prime the lead wire using Grey (AK-758).

Brush paint the lead wire with 'Tamiya' Rubber Black (XF85).

Check then cut the lead wire to a length that will allow it to be attached to the connection on the bottom of the gun breech block and then route forward to the guns synchronization mechanism.

Position each lead wire and secure in position using CA adhesive.

Position each empty round chute (A13) against the ejection port of the machine gun and with the 'tail' of the chute entering the empty rounds container.

Secure the empty rounds chutes against the breech block and if necessary the empty rounds container, using CA adhesive.

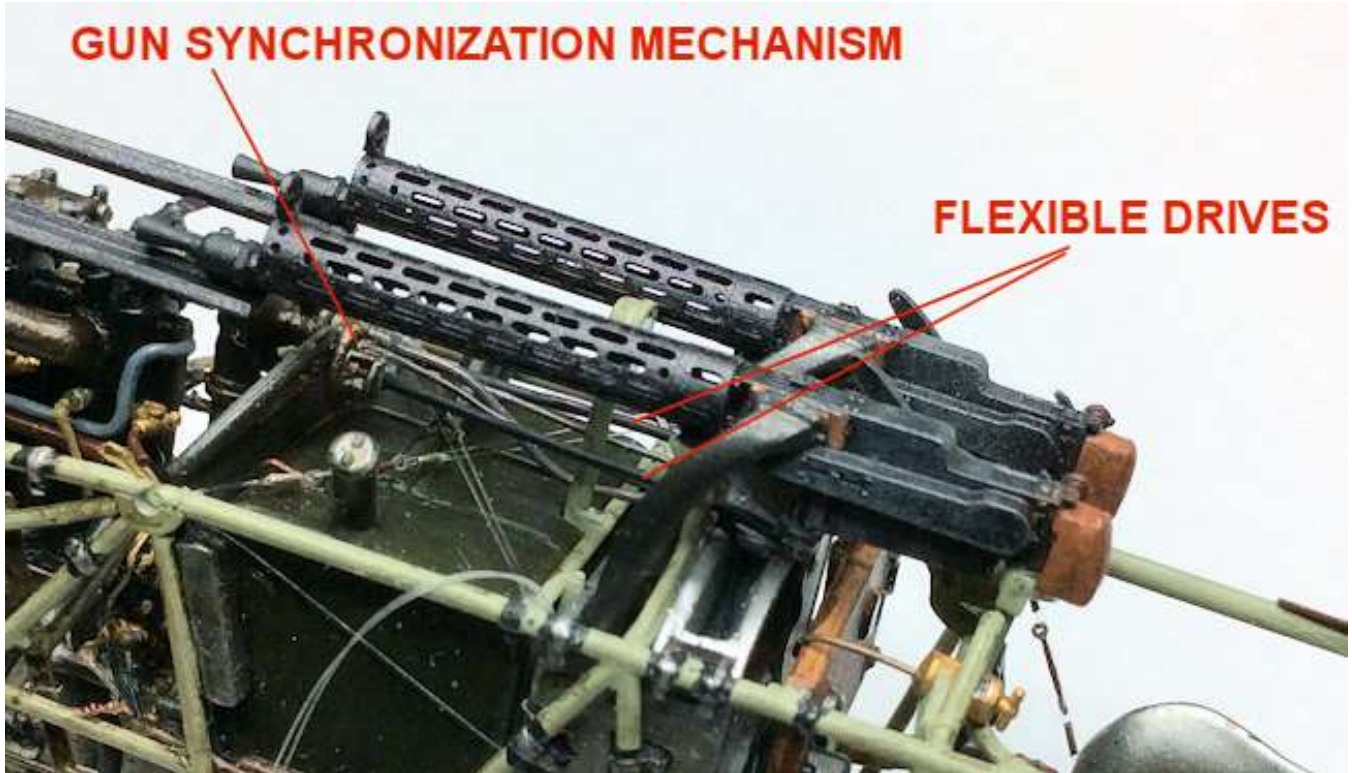

92. Tail unit:

The tail unit comprises the tail plane, elevator, fin and rudder, all of which are 3D printed parts.

NOTE: Take extreme care when handling the 3D printed parts of the tail unit, as once released from the support frame they are very weak and easily broken.

Using a very fine saw, such that from 'RB Productions' (handle RB-T013 and ultra-fine saw blade RB-T017), carefully cut through the supports to separate the parts from the frame.

Carefully saw and sand away any stubs left from the support,

Using the saw, carefully cut through the vertical rudder post at the two top locations for locating the fin.

Drill a hole of 0.2 mm diameter through both ends on the kit supplied control horns (D17 x2 for the elevator and D17 for the rudder).

Drill a hole of 0.2 mm diameter through the top corner of the fin frame and a 0.3 mm hole through the outer rear corners of the tail plane frame and angled towards the top rear corner of the fin (for the bracing cable turnbuckles).

Test fit the control horns into their locating slots in the rudder and trailing edge of the tail plane. Carefully sand the slots if necessary.

Locate the control horns D17 into their slots on the tail plane and secure in position using CA adhesive.

Locate the control horn D17 onto the rudder post towards the bottom and then secure in position using CA adhesive.

NOTE: *In the following step, make sure the tail plane is the right side up - that is the offset fin mounting at the front should be to the left.*

Position the elevator onto the trailing edge of the tail plane and working from one side then across to the other, secure in position using CA adhesive.

Locate the two lugs on the rear of the fin into the slots in the rudder post (upper two) and secure in position using CA adhesive.

NOTE: *The Fokker D.VII had the rudder fitted offset to the left. This can be seen when the fin is fitted to the tail plane.*

Locate the front and rear pegs on the bottom of the fin into the pre-molded location holes at the centre rear of the tail plane and the offset (to the left) mounting at the front of the tail plane.

NOTE: *The 3D printed elevator I received had, I believe, a 'short shot' during printing, in that the curved inboard trailing edge (towards the rudder) is missing (see photo above). To rectify this:*

Carefully cut through the inboard trailing edge corners of both sides of the elevator to as to separate the trailing edges from the elevators inboard ribs.

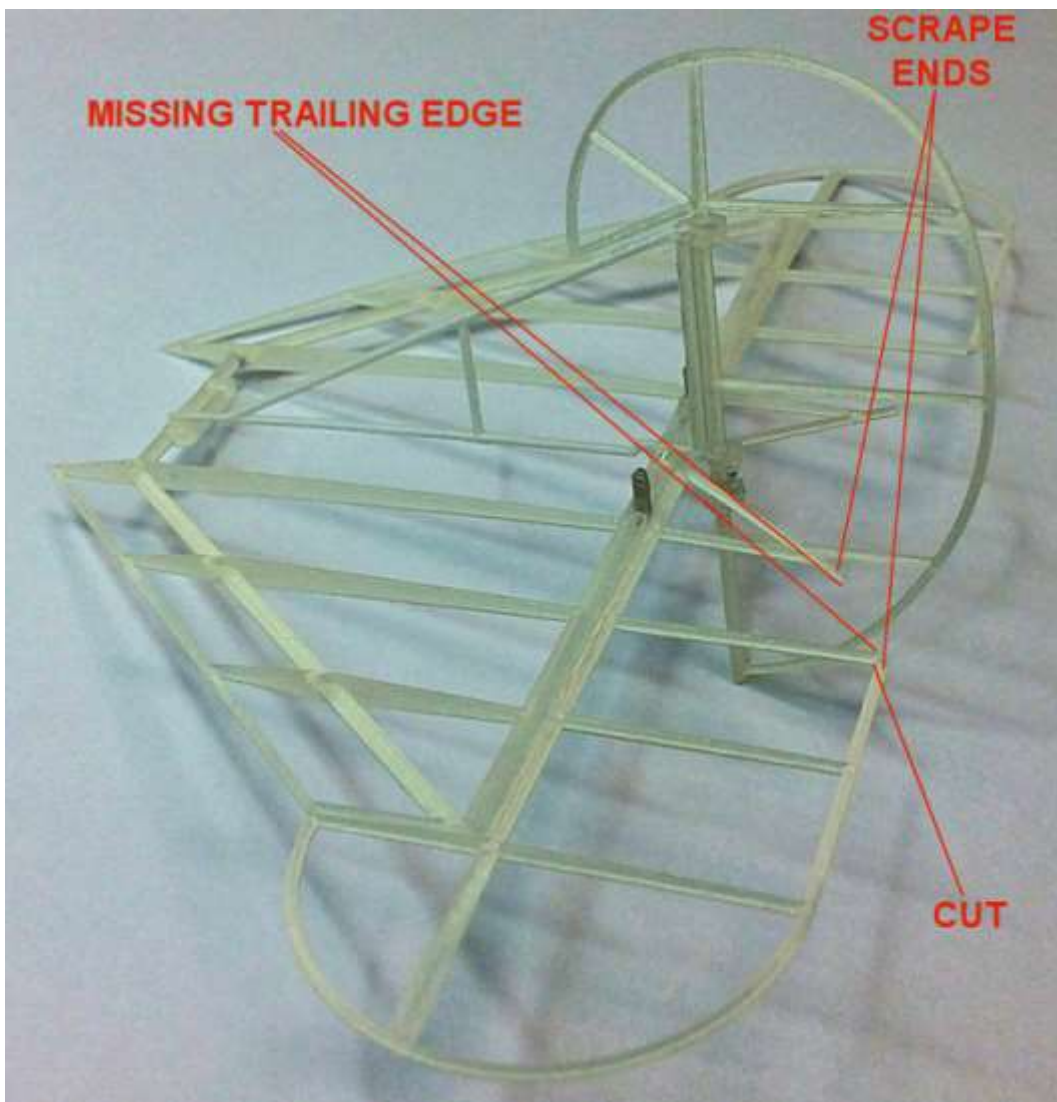

Cut two lengths of 'Albion Alloys' 0.8 mm diameter brass tube (MBT08), which has a 0.6 mm internal bore.

Using a sharp blade, gently scrap away material from the two ends of the trailing edges until the cut tube can be slid onto the trailing edge ends.

Bend the tubes to form the required curve that will join the two ends of the trailing edges. Locate the tubes onto the trailing edges and secure using thin CA adhesive.

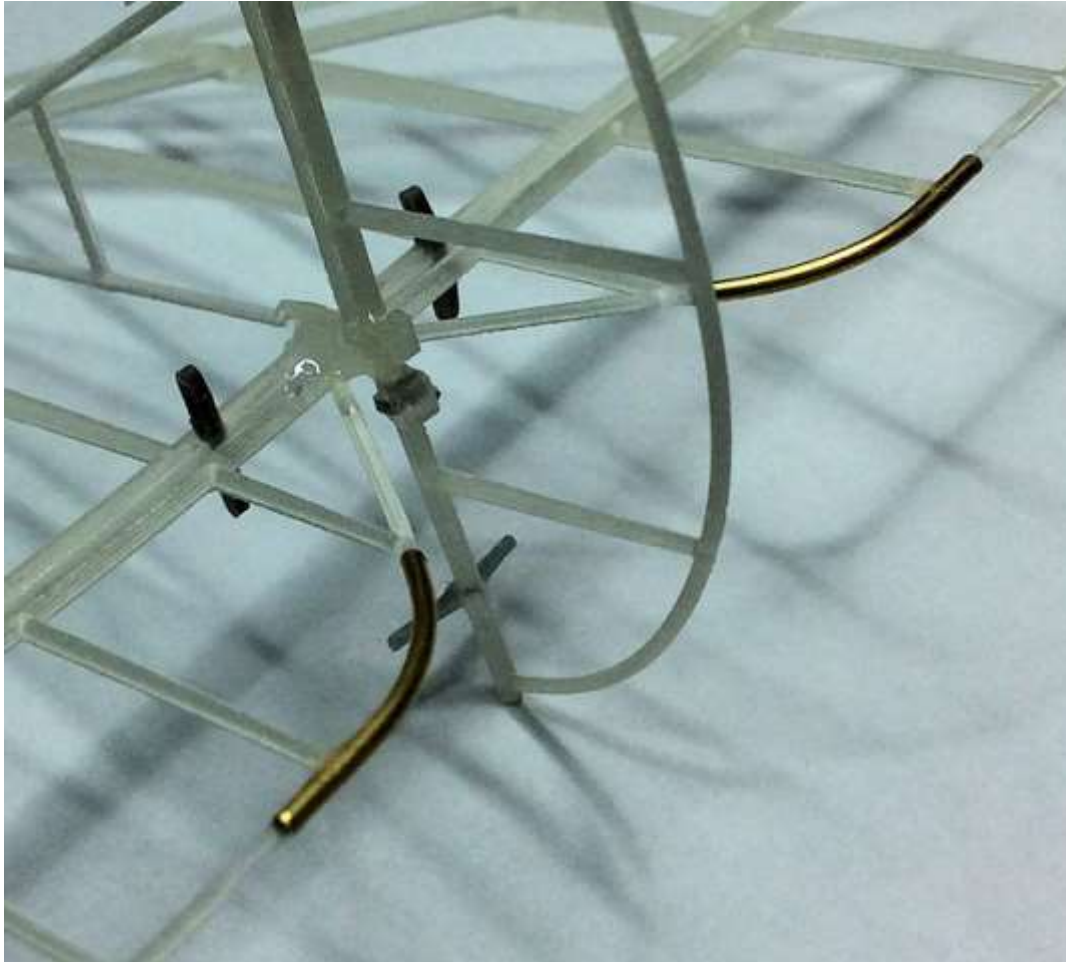

NOTE: The 3D printed tail plane and elevator does not have the outer mounting block for the elevator hinges. Also there should be bracing tubes fitted diagonally across the forward outer corners of the elevator. These details need to be added.

Cut small blocks from a sheet of 1.0 mm thick plastic card.

Position a block on the rear face of the elevator front spar, in the corner opposite the outer edge of the tail plane.

Cut two lengths of 'Albion Alloys' 0.5 mm diameter brass tube (MBT05) to span across the forward outer corners of the elevator.

Position the tubes in the elevator and secure in position using CA adhesive.

Airbrush prime the assembly and tail plane support struts (kit part B24) using Grey (AK-758).

Airbrush prime the assembly and tail plane support struts using 'Tamiya' Grey Green (XF76).

NOTE: *The tail assembly was constructed from tubular metal, apart from the tail plane rear spar, rudder and fuselage rear post and the hinge blocks for the rudder and elevator.*

Brush paint the wood parts with 'Tamiya' Deck Tan (XF78).

Apply your desired wood effect (refer to Part 3 of this build log) to the wood parts - I used 'DecoArt' Burnt Sienna acrylic oil paint.

Brush paint the rudder and elevator control horns with 'Tamiya' Rubber Black (XF85).

Make sure the pre-drilled 0.2 mm diameter holes in the control horns, the top corner of the fin frame and the outer rear corners of the tail plane frame are clear of primer and paint.

Brush paint the metal hinge straps of the rudder and elevator with 'Mr. Colour' Stainless Steel (213).

Airbrush several light coats of Alclad Light Sheen (ALC-311) lacquer over the assembly.

Refer to Part 3 of this build log - Apply the Flory clay wash (Dark Dirt) over the assembly.

Airbrush a sealing coat of Alclad Light Sheen (ALC-311) lacquer over the assembly.

Rudder and Elevator - control cables:

The control cables for the rudder and elevator were pre-installed earlier in the build. These control cables now need to be joined to extensions for attaching later to their respective control horns.

NOTE: *When finally installed the turnbuckles for the rudder and elevator control cables are located below the pilot's seat. Pre-rigging of these control cables has already been completed.*

Cut twelve short lengths of 'Albion Alloys' 0.4 mm Nickel-Silver tube (NST04).

Prepare six 'Gaspatch' 1/48th scale turnbuckles (Type C) by breaking it off the base and filing the tag away (diamond file).

NOTE: *Thread the pre-installed control cables through the side of the cockpit frames, which makes it easier to add the continuation cables.*

Thread the free end of a control cable through a cut tube then through the 'eye' end of a turnbuckle.

Loop the cable back through the tube, leaving the loop open and the turnbuckle clear of the fuselage assembly (this allows the turnbuckle to be correctly positioned in the cockpit).

Cut a long length of 'Stroff' mono-filament (0.08 mm diameter).

Thread the cable through a cut tube then through the remaining 'eye' end of the turnbuckle.

Loop the cable back through the tube and tension the free end of the cable to draw the tube up to, but not touching the turnbuckle.

Make sure the tube is not in contact with the turnbuckle 'eye' end.

Secure the tube to the cable using CA adhesive.

Carefully trim away the exposed free end of the cable.

Hold the free end of the 'loose' turnbuckle cable and tension the free end of the cable to draw the tube up to, but not touching the turnbuckle. Make sure as you do this that the turnbuckle will be in the correct position (under the pilot's seat) when the control cable is connected to its control horn on the rudder or elevator.

Make sure the tube is not in contact with the turnbuckle 'eye' end.

Secure the tube to the cable using CA adhesive.

Carefully trim away the exposed free end of the cable.

Repeat this procedure so that turnbuckles are attached to the two rudder cables and four elevator cables.

94. Tail unit assembly - installing:

The tail unit assembly should now be fitted prior to connecting the rudder and elevator control cables to their respective horns.

Locate the tail assembly onto the top rear of the fuselage.

Make sure the front of the assembly sits centrally on the top of the fuselage frame.

Make sure the rudder post is aligned with the bottom post on the rear of the fuselage.

Make sure the bottom tube of the fin structure is central along the top of the fuselage.

Secure the assembly in position by applying CA adhesive:

Between the front of the assembly to fuselage joint.

Under the assembly at the top rear of the fuselage.

Between the bottom of the rudder post and bottom 'stub' at the rear of the fuselage.

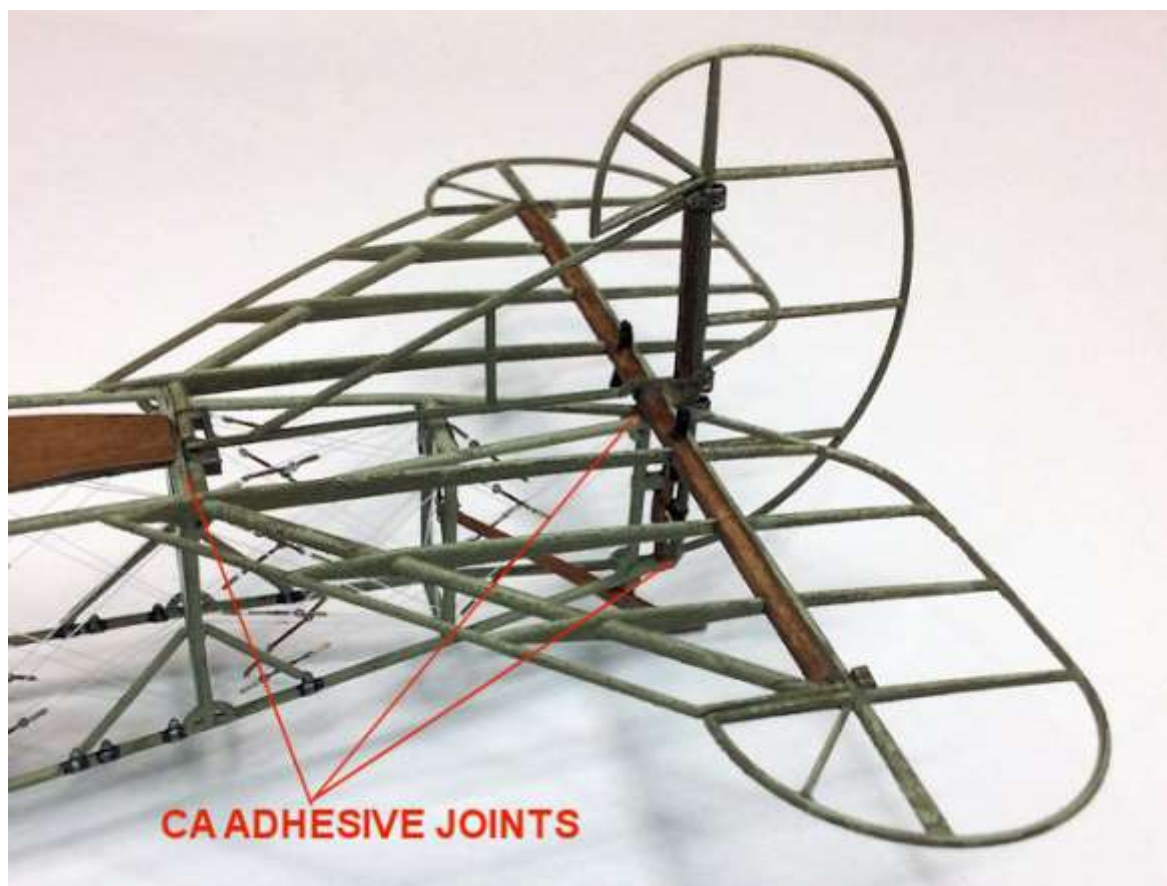

NOTE: *In the following step, the tail plane support struts are 'handed'. When fitting, make sure the support struts are fitted to the correct side of the fuselage and with the thicker leading edge facing forwards.*

Locate the two tail plane support struts (kit items B24) into the pre-molded 'hoops' on each side of the rear of the fuselage and under the outboard edge of the tail plane rear spar.

Secure the struts in position using CA adhesive.



Bracing cable:

A single bracing cable was fitted from outer ends of the tail plane rear spar and through the top, rear corner of the fin. Turnbuckles were fitted at each end of the cable at the tail plane rear spar.

NOTE: *Care must be taken when fitting this bracing cable. Too much tension may cause damage or distortion to the structure of the tail assembly.*

Cut a long length of 'Stroft' mono-filament (0.08 mm diameter).

Cut four short lengths of 'Albion Alloys' 0.4 mm Nickel-Silver tube (NST04).

Prepare two 'Gaspatch' 1/48th scale turnbuckles (Type 'one end') by breaking them off the base and filing the tags away (diamond file).

Thread the mono-filament through a cut tube then through an 'eye' end of a turnbuckle.

Loop the mono-filament back through the cut tube.

Slide the tube up to but not touching the turnbuckle 'eye' end.

Keeping the turnbuckle and mono-filament inline, secure the tube in position using CA adhesive.

Insert the turnbuckle into one of the pre-drilled 0.3 mm holes in the outer ends of the tail plane rear spar.

Secure the turnbuckle in position using CA adhesive. Make sure the turnbuckle is aligned with the top, rear corner of the fin.

Slide another cut tube onto the line then pass the line through the pre-drilled 0.2 mm hole in the top, rear corner of the fin.

Thread the free end of the mono-filament through two more cut tubes then through the 'eye' end of the second turnbuckle.

Loop the mono-filament back through the cut tube, but leave the loop loose.

Insert the turnbuckle into the remaining pre-drilled 0.3 mm hole in the outer end of the tail plane rear spar.

Secure the turnbuckle in position using CA adhesive. Make sure the turnbuckle is aligned with the top, rear corner of the fin.

Carefully pull the free end of the line to tighten the line and draw the cut tubes to the turnbuckle.

NOTE: *During the next step, move the tubes apart to prevent both from being secured to the line and turnbuckle.*

Keeping the turnbuckle and mono-filament inline, secure the first tube in position using CA adhesive.

The fin and rudder are fragile and easily distorted with the line tensioned. Check that the fin and rudder are vertical.

Slide the remaining two tubes up the top, rear corner of the fin and secure in position using CA adhesive.

Paint the body of the turnbuckle with a 50/50 mix of 'Tamiya' Copper (XF6) and Hull Red (XF9).

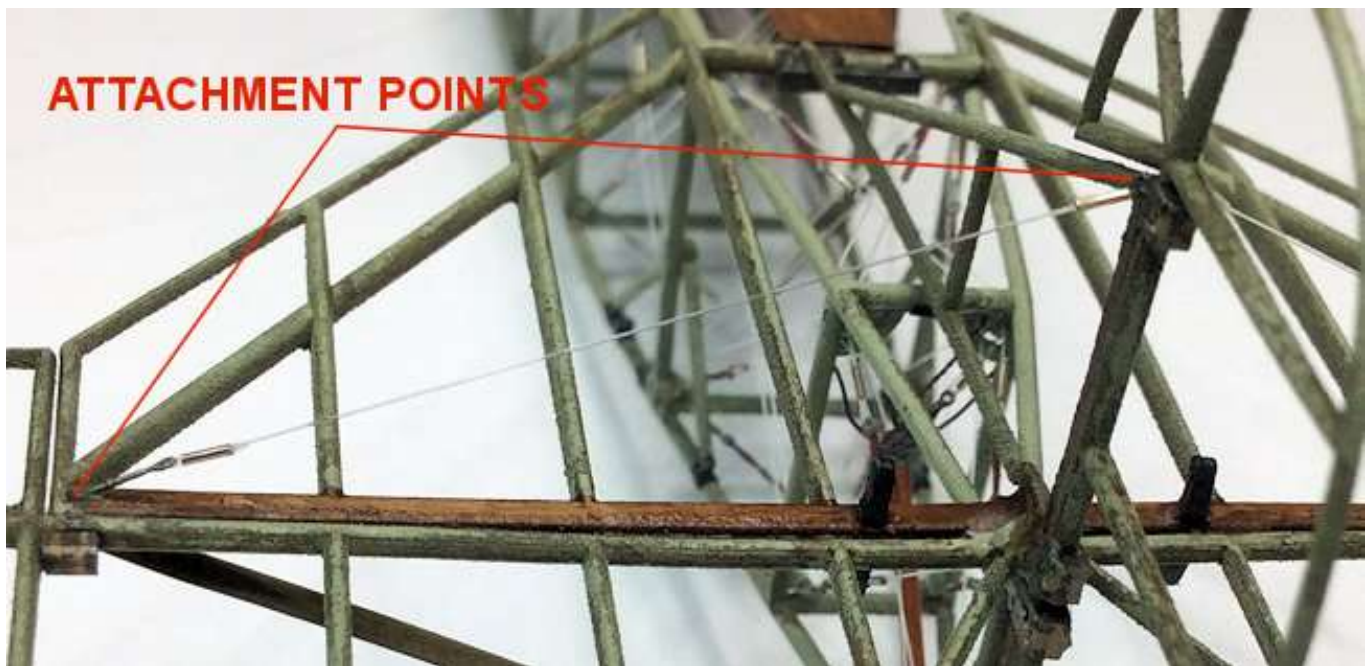

95. Connecting the rudder and elevator controls:

With the rudder and elevator control cables rigged and the tail assembly fitted to the fuselage, the control cables can now be connected to the rudder and elevator.

Elevator lower control cables - The lower control cables are pre-attached to the bottom of the control column, under the cockpit floor.

From the cockpit, pass the free end of the left control cable through the lower aperture in the pilot's seat support frame.

Carefully route the cables rearwards through the fuselage, avoiding the installed cross bracing cables. Exit the cables out of the fuselage through the second to last frame bay.

Slide a cut 0.4 mm Nickel-Silver tube onto the free end of the cable.

Pass the cable through the pre-drilled 0.2 mm diameter hole in the end of the upper, left elevator control horn.

Loop the cable back and through the tube.

Gently tension the free end of the cable to draw the tube up to the control horn whilst keeping the cable taut. Make sure the cable runs straight and is not deflected from any fuselage cross bracing cables.

Secure the tube in position using CA adhesive.

Cut away any excess cable from the tube.

Repeat this procedure for attaching the other control cable to the lower, right control horn.

Cut away any excess cable from the tube.

Repeat this procedure for attaching the other control cable to the upper, right control horn.

Elevator upper control cables - The two upper elevator control cables are pre-attached to the control column, above the cockpit floor.

From the cockpit, pass the free end of the left and right control cables through the upper aperture in the pilot's seat support frame.

Repeat the previous procedure for attaching the control cables, but to the lower left and right control horns.

Rudder control cables - The two control cables are pre-attached to the pilot's rudder bar.

From the cockpit, pass the free end of the left and right control cables through the upper aperture in the pilot's seat support frame.

Repeat the previous procedure for attaching the control cables, but to the left and right rudder control horns.

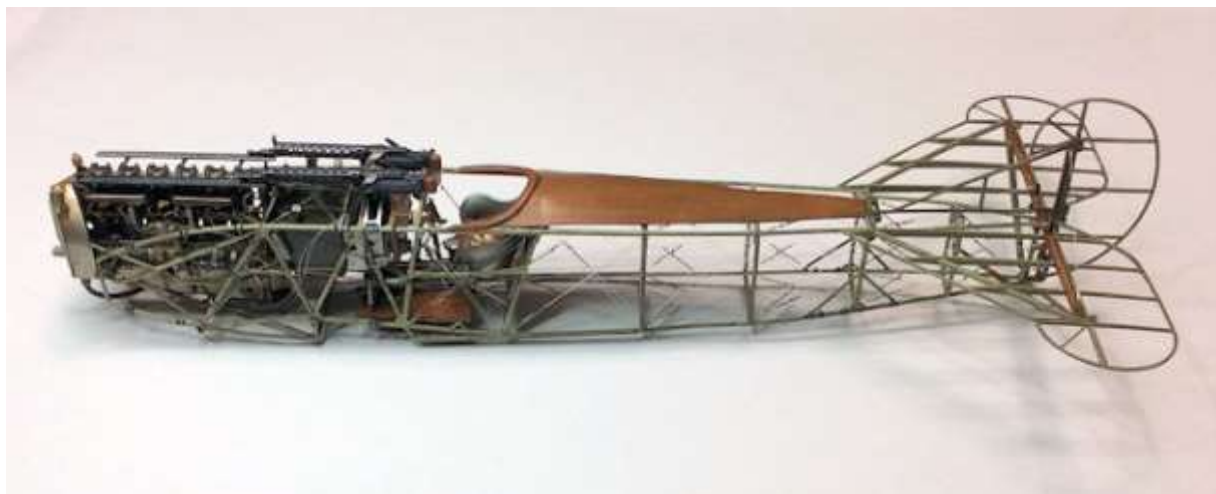

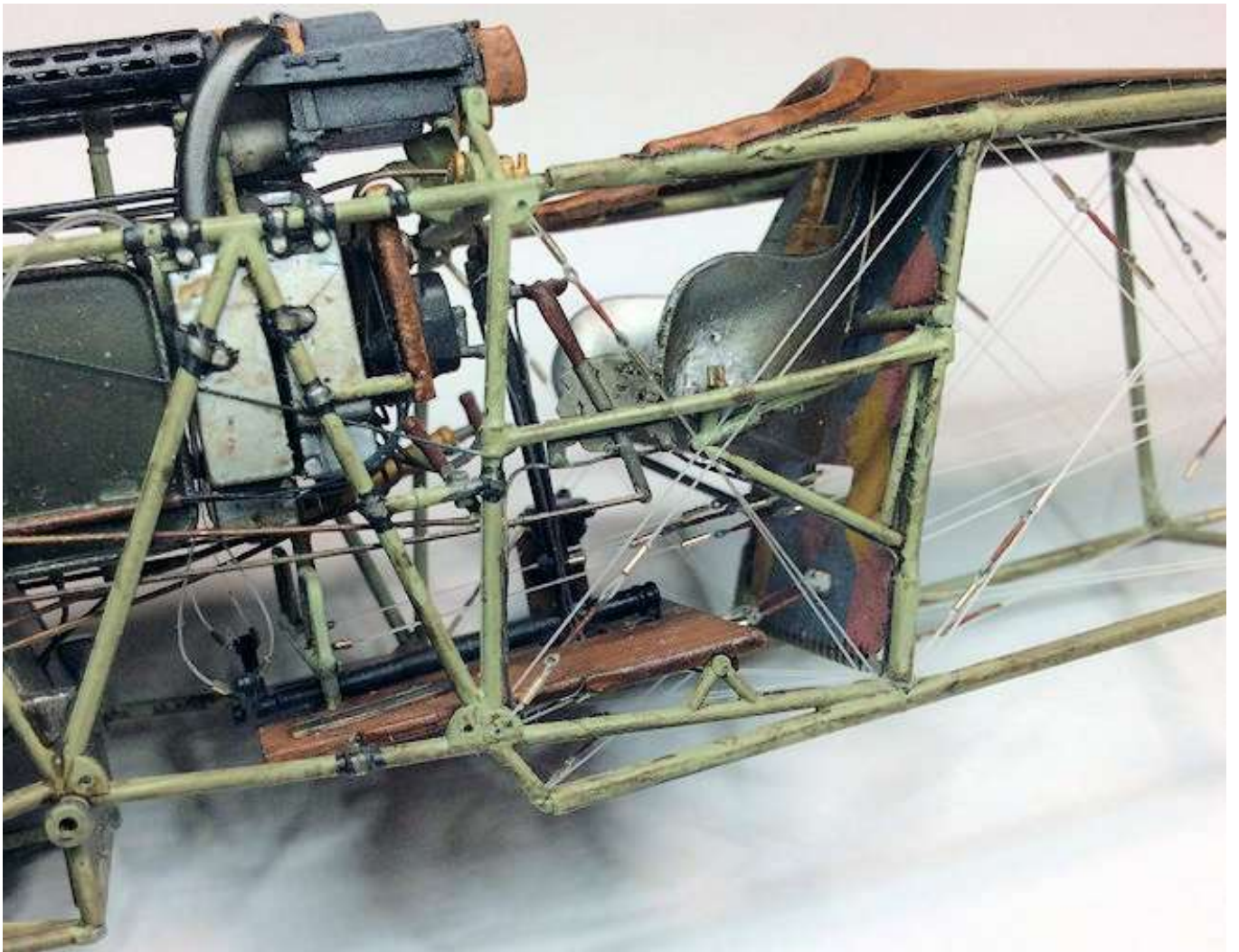

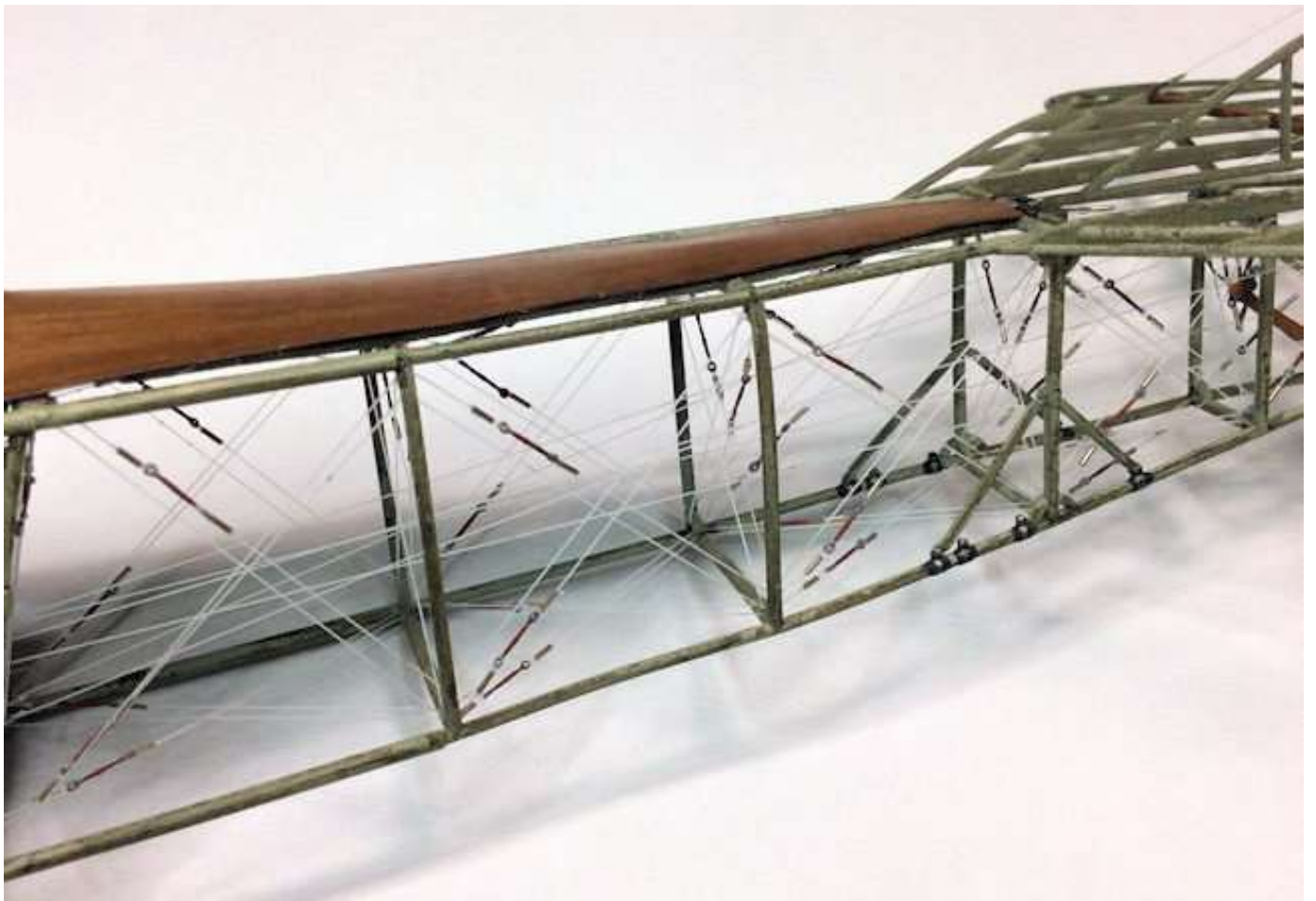
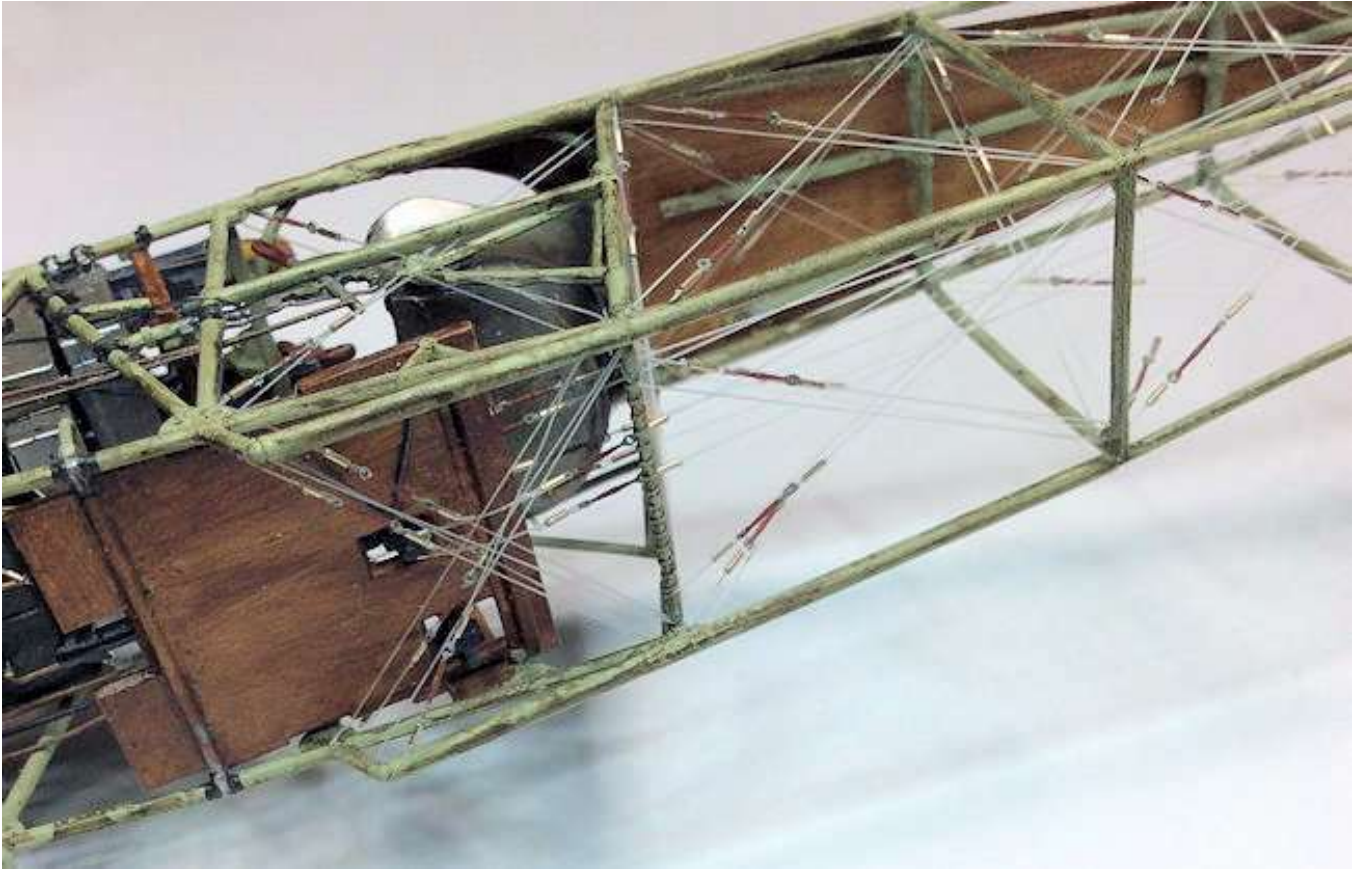

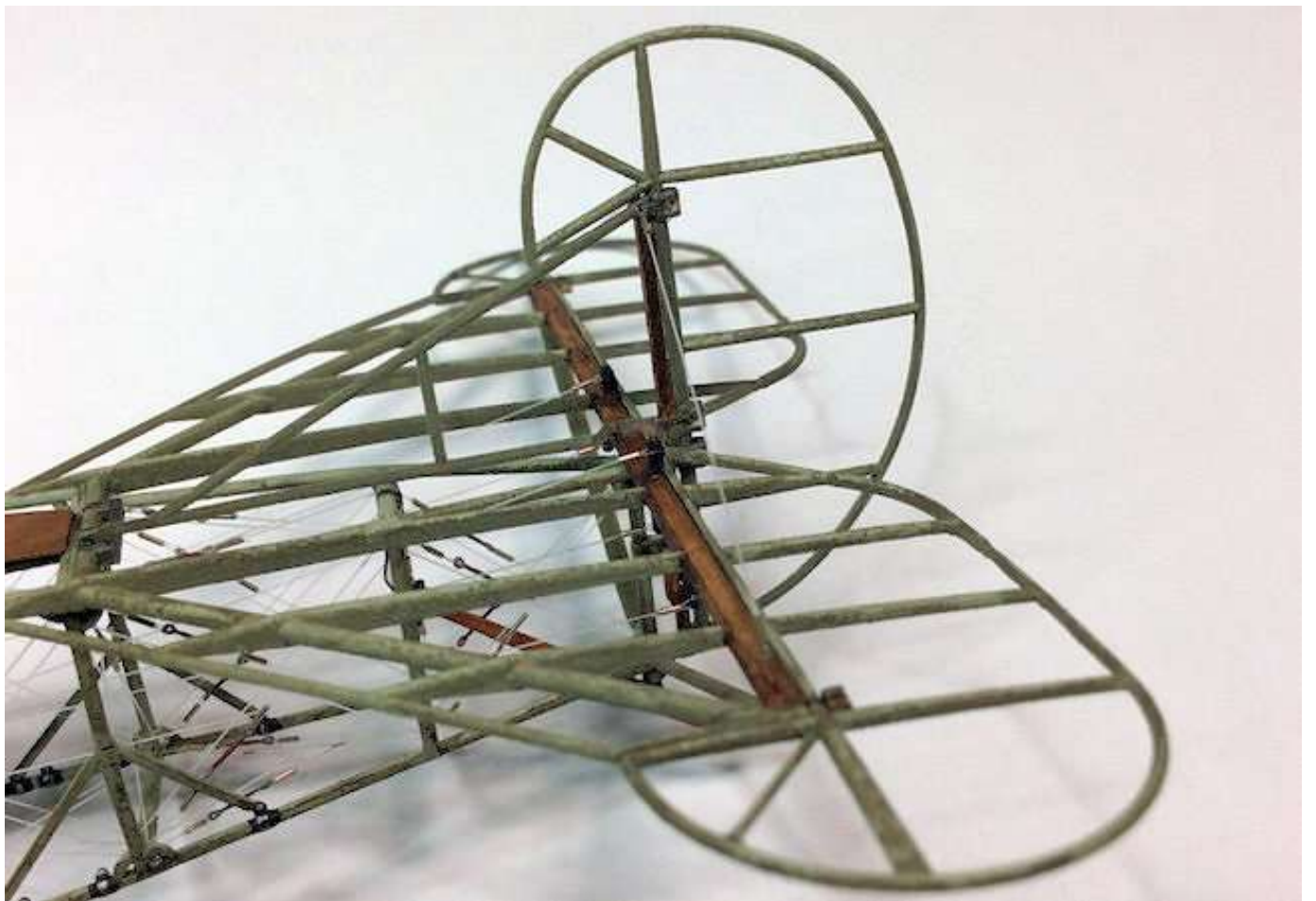

PART 9 - LOWER WING

Now that the fuselage assembly has been completed, it's time to move on to the wings and undercarriage assemblies. As the undercarriage struts are attached to the fuselage side frames and lower wing, it shouldn't be started until the lower wing has been fitted.

Lower wing:

The 3D printed lower wing consists of the left and right wings, which are joined under the fuselage centre section by overlapping front and rear wing spars. Both wings are molded with access holes through wing ribs to allow the fitting of cross bracing cables. Although detailed the wings are lacking certain detail:

Plywood 'saw tooth' leading edge fairings.

Bracing cables.

Diagonal bracing struts at the wing tip and wing root trailing edges.

Leading edge 'bump stops', used to protect the wings during stacking or transporting the wings when removed from the aircraft.

Optional: Early production Fokker D.VII aircraft were fitted with bracing tapes that were routed across the wings between the front and rear wing spars and between the rear wing spar and the wing trailing edge. These tapes were routed in a diagonal 'zig-zag' form, up and over each wing rib. Later production aircraft, such as those built by OAW, were fitted with 10 mm square strip wood as replacements for the earlier tapes. In fact some Fokker D.VII aircraft had a mixture of strip wood and tapes fitted. The 3D printed wings represent the later, strip wood version. Although these strip wood struts can be left to make the model build easier, I chose to remove the wings strip wood struts and represent the earlier bracing tapes.

Trailing edge wire across the wing ribs, for attaching the linen covering.

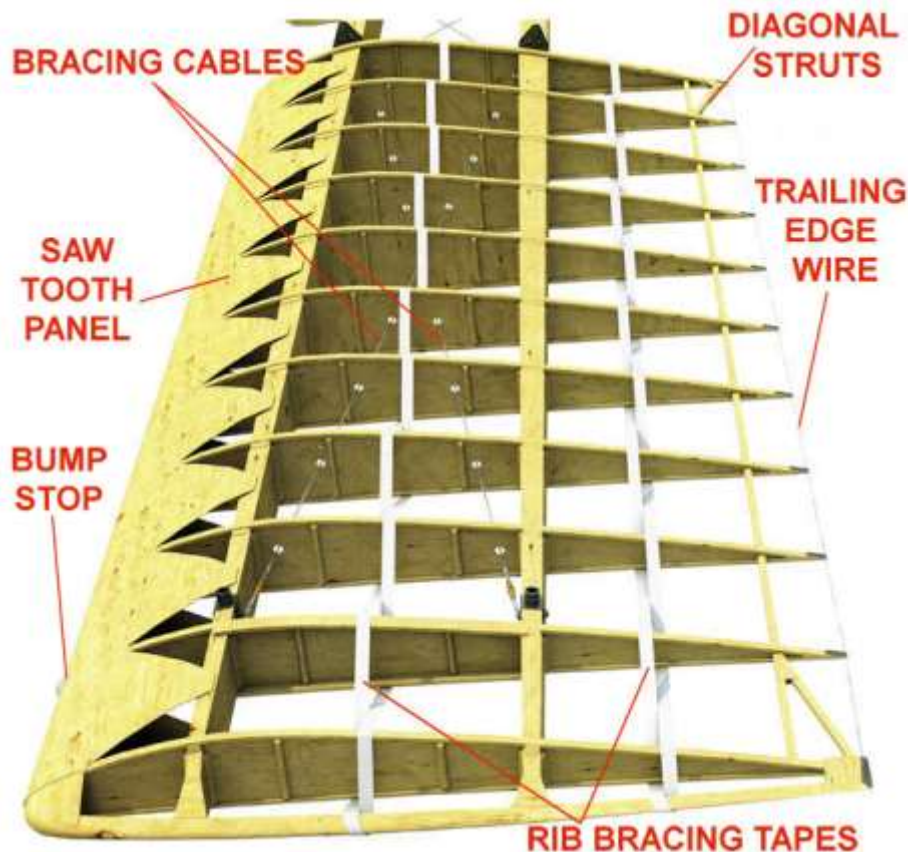

Surface preparation:

Despite cleaning the 3D printed wings in accordance with the instructions, I found that the surfaces of the wings still had crusty wax support material present. I scrapped this off using a straight scalpel blade.

Optional bracing tapes:

Carefully cut away the represented strip wood bracing struts and sand off any remaining 'stubs'

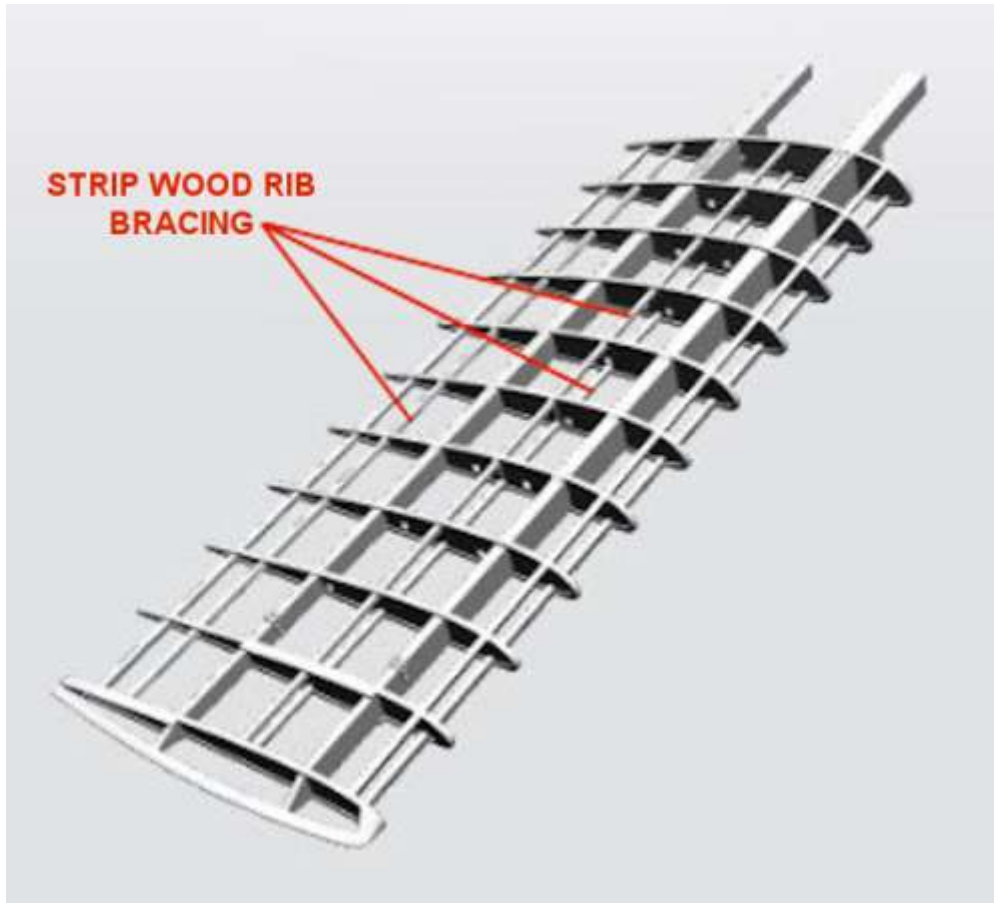

Cross bracing attachment points:

Drill a 0.5 mm diameter hole through the front and rear wing spars (from front to rear) at the wing strut mounting points. These will be used for attaching the cross bracing cables.

Wing spar joints - wing dihedral angle:

NOTE: *When I test joined the wing spars together on my 3D printed wings, I found that the wings tips were too high from the horizontal (too much wing dihedral angle). This may have been a result of 3D printing process or may have been just on the set I received. On the actual aircraft there was virtually no dihedral angle on either the upper or lower wing.*

With the two lower wings held together at the wing spars, make a note of how much of the joint faces if the wing spars needs to be removed to allow a good joint and with the wings virtually flat.

Carefully scrape away material from the four wing spars to attain a good joint with the wings flat.

NOTE: As the wing spar joints will take the full weight of the model, I chose to use a two part epoxy adhesive for the joints, rather than CA adhesive, which can set brittle and be easily parted.

Make a mix of two part epoxy adhesive, such as 'Araldite', and apply to the mating faces of the wing spars.

Position the two lower wings together, making sure the two wings are aligned and straight then clamp the spars together.

Allow the adhesive to fully set (at least overnight).

Diagonal bracing struts:

To create the missing diagonal bracing struts at the wing tips and wing root trailing edges, first cut four lengths of 'Albion Alloys' 0.5 mm diameter Nickel-Silver tube (NST05).

Locate the four bracing struts and secure in position using CA adhesive.

Primer check:

Airbrush the wings with a light coat of Grey-758 primer.

Check the surfaces of the wings for any evidence of roughness, deposits etc and where necessary, scrape clean those areas again.

Reapply primer to any areas reworked.

Plywood 'saw tooth' leading edge fairings:

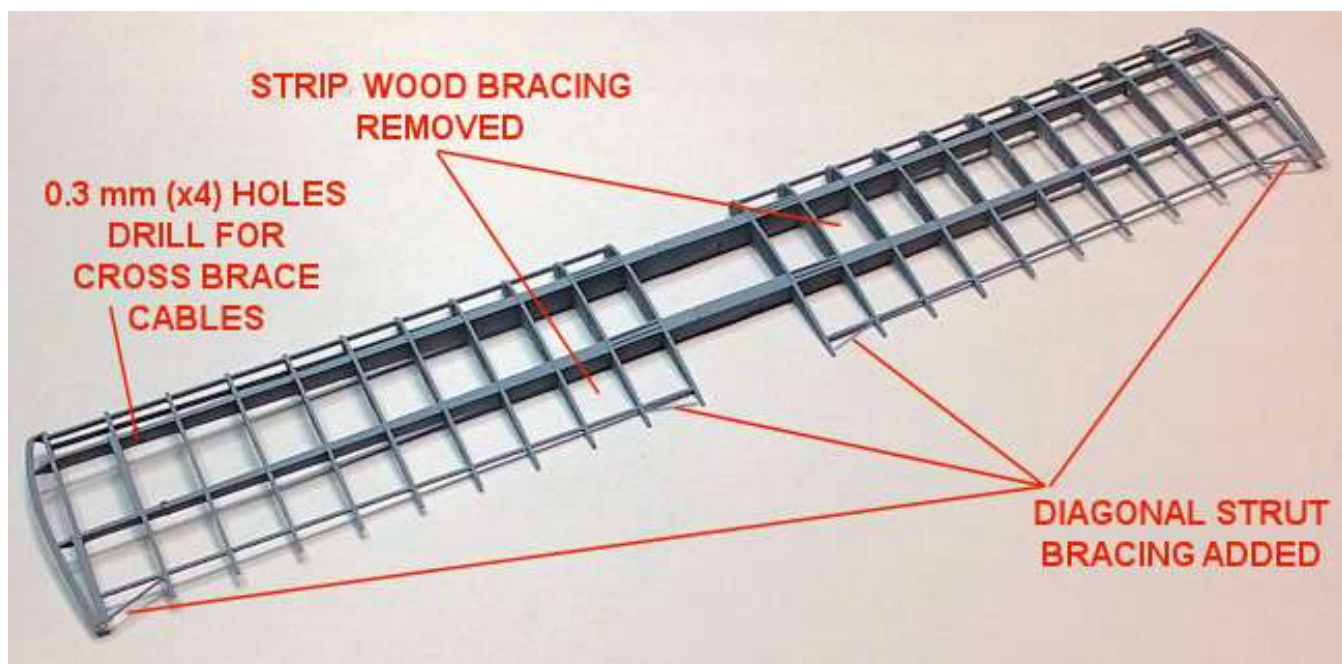

At this stage the 'saw tooth' leading edge plywood panels should be created.

First obtain a copy of the wing structure, such as that on page 34 of 'Fokker D.VII - Anthology 1', published by 'Albatros Publications Ltd 1997'.

Using PC software, scan the page and then increase the size of the image and print the image onto paper.

Overlay the wing assembly over the print to ensure the wing structure aligns with the print. If necessary adjust the print size until this is achieved.

Cut out the 'saw tooth' fairing shape from the print then separate it by cutting across the centre line to create two 'saw tooth' panels.

Test fit the two templates to the wing leading edges and tape the two together once the positioning is correct.

Check again to make sure the panels are aligned correctly with the 'saw tooth' tips located on the rear of the wing spar and between the wing ribs.



Trace the outline of the template onto a sheet of 0.2 mm thick plastic card then cut out the panel.

Position the tips of the fairing on the top of the wing front spar, centrally between the wing ribs and secure in position using thin CA adhesive.

Apply the CA adhesive over and around the wing rib profiles then keeping the fairing in contact, roll the wing assembly over the fairing to adhere it around the curved fronts of the wing ribs.

Once set, reinforce the adhesion by applying more CA adhesive along the fairing to wing spar mating faces.

Apply adhesive to the bottom of the wing front spar and hold the fairing tips in contact until the adhesive has set.

At the wing tip, apply adhesive on both sides of the end frame then pinch in the top and bottom of the fairing and hold until the adhesive sets.

Finally file or sand away any exposed edges of the fairing.

Repeat this procedure to create the 'saw tooth' fairing on the other lower wing.

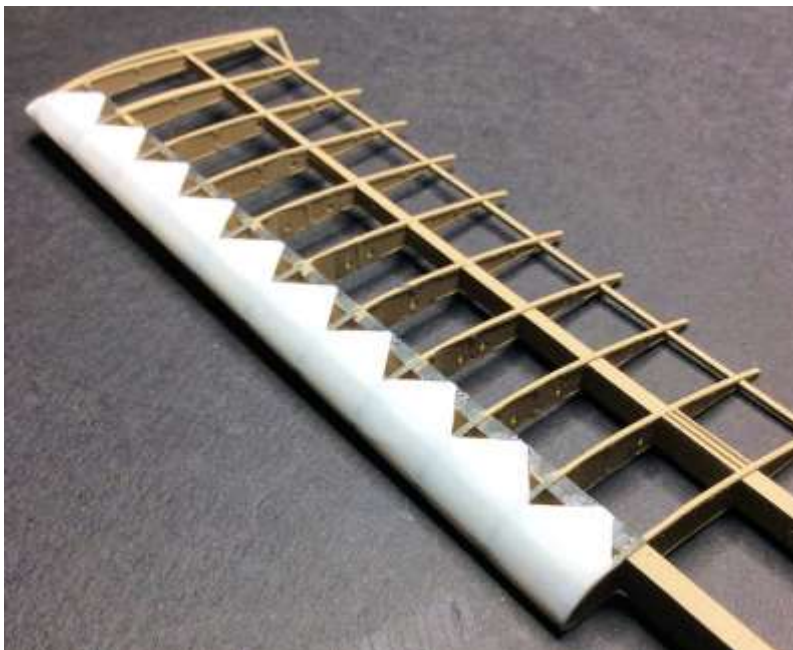

Airbrush the wing assembly using primer (Grey-AK 758).

Once dry, airbrush the wing assembly with 'Tamiya' Deck Tan (XF78).

NOTE 1: *During the following step, I applied the 'grain' of the wood effect on the outer surface of the 'saw tooth' leading edge panels from front to rear (with the air flow), as I couldn't find evidence of the grain spanning the panels.*

NOTE 2: *During the following step, apply the oil paint to the inside of the leading edges and 'saw tooth' panels' using a long and brush. It is impossible to create a wood grain effect in these areas, but they can't really be seen and at least the oil colour will match the exterior wood grain effect.*

Apply your desired wood effect to the wing assembly and 'saw tooth' panels (refer to Part 2 of this build log) - I used 'DecoArt' Burnt Sienna acrylic oil paint for the primary structure with Burnt Umber highlighted over the leading edge 'saw tooth' fairings.

Airbrush a light sealing coat of 'Alclad' Light Sheen (ALC-311) with a small amount of 'Tamiya' Clear Orange (X26) added.

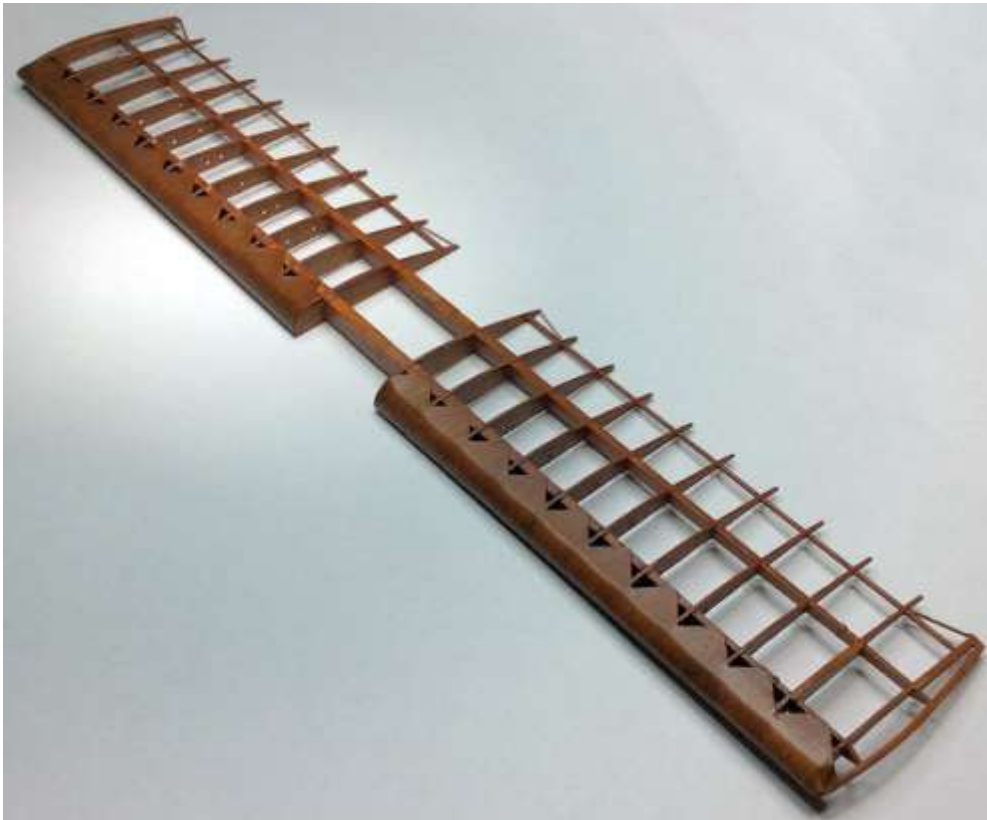

Wing cross bracing cables:

Cut twelve short lengths of 'Albion Alloys' 0.4 mm Nickel-Silver tube (NST04).

Prepare six 'Gaspatch' 1/48th scale turnbuckles (Type C) by breaking it off the base and filing the tag away (diamond file).

Cut eight long lengths of 'Stroft' mono-filament (0.08 mm diameter).

Thread the free end of a line through a cut tube then through the 'eye' end of a turnbuckle.

Loop the cable back through the tube and tension the free end of the cable to draw the tube up to, but not touching the turnbuckle.

Make sure the tube is not in contact with the turnbuckle 'eye' end.

Secure the tube to the line using CA adhesive.

Carefully trim away the exposed lines leaving just the tube.

Attach a line to the opposite end of the turnbuckle to create a turnbuckle with a tube only at one end of the turnbuckle and line attached to the other side of the turnbuckle.



From the rear of the wing front spar, pass the tube into the pre-drilled 0.5 mm hole in the wing front spar, leaving the tube just proud.

NOTE: *In the following step, make sure the line from the turnbuckle is free to move and secured by the adhesive.*

Secure the tube in the front spar using CA adhesive.

Pass the free end of the turnbuckle line diagonally through the holes in the wing spars to , exit at rear hole at the wing centre section.

From within the wing centre section, thread the line through a cut tube then through the 'eye' end of a turnbuckle.

Loop the line back through the tube, leaving the loop of line open and loose.

Thread the free end of another line through a cut tube then through the remaining 'eye' end of the turnbuckle.

Loop the cable back through the tube and tension the free end of the cable to draw the tube up to, but not touching the turnbuckle.

Make sure the tube is not in contact with the turnbuckle 'eye' end.

Secure the tube to the line using CA adhesive.

Carefully trim away the exposed free end of the line.

Pass the free end of the line diagonally across the wing centre section and through the forward hole in the wing rib.

Pass the free end of the turnbuckle line diagonally through the holes in the wing spars to , exit at rear hole at the wing trailing edge.

Keeping the line tensioned, pull the free end of the 'open loop' on the previous wing centre section turnbuckle, to draw the tube up to but not touching the turnbuckle. Also make sure the other turnbuckle is positioned close to the forward corner of the wing centre section.

Make sure the tube is not in contact with the turnbuckle 'eye' end.

Secure the tube to the cable using CA adhesive.

Carefully trim away the exposed free end of the line.

At the wing trailing edge end of the line, pass the free end of the line through a cut tube then through the 'eye' end of a turnbuckle.

Loop the cable back through the tube leaving the line loop open and loose.

Thread the free end of a line through a cut tube then through the remaining 'eye' end of the turnbuckle.

Loop the cable back through the tube and tension the free end of the cable to draw the tube up to, but not touching the turnbuckle.

Make sure the tube is not in contact with the turnbuckle 'eye' end.

Secure the tube to the cable using CA adhesive.

Cut away the exposed lines from the tube, leaving the tube attached to the turnbuckle.

From the forward face of the wing rear spar, pass the tube into the pre-drilled 0.5 mm hole in the wing rear spar, leaving the tube just proud.

NOTE: *In the following step, make sure the line from the turnbuckle is free to move and secured by the adhesive.*

Secure the tube in the front spar using CA adhesive.

Keeping the line tensioned, pull the free end of the 'open loop' on the turnbuckle, to draw the tube up to but not touching the turnbuckle.

With the line in tension, secure the tube to the line using CA adhesive.

Cut away any exposed free line from the turnbuckles tubes.

Brush paint the body of the turnbuckle with a 50/50 mix of 'Tamiya' Copper (XF6) and Hull Red (XF9).

Repeat this procedure to create the other bracing cable.



Leading edge 'bump stops':

Cut two short lengths of 1.0 mm diameter plastic rod.

Using a sander, round off one end of each rod.

Prime the rods with Grey-758.

Brush paint the rods with 'Tamiya' Rubber Black (XF85).

Drill a 1.0 mm diameter hole through the centre of the leading edge 'saw tooth' fairing, in line with the wing strut mounting locations.

Locate the rods into the holes with the round end visible. The rods should be positioned just proud of the leading edge surface.

Cement the rods in position.



Optional - wing rib bracing tapes:

NOTE: *The strips of plastic card used to create the bracing tapes may be easily broken when stressed. Should this occur, cut the end of the strip back to a wing rib (if possible) and secure it in position with CA adhesive. Then cement another strip to the cut end and continue.*

From 0.2 mm thick plastic card, cut a long strip of approximately 0.5 mm width.

Bend one end to 90 degrees and position this strip on top of an inboard wing rib, just forward from the centre between the wing front and rear spars.

Secure the bent end to the inboard side of the wing rib, using CA adhesive.

Flex the strip down and under the next outboard wing rib.

Make sure the strip is parallel with the wing front spar.

Secure the strip to that wing rib using CA adhesive.

Working outboard, secure the strip to each wing rib forming a vertical 'zig-zag'.

At the outer wing tip rib, carefully flex the strip around the rib and close to the edge of the strip already laid, then secure in position using CA adhesive.

NOTE: During the next step the bracing tape will be directionally opposed to the tape already laid.

As before form a 'zig-zag' bracing tape running back to the inboard rib.

Secure the end of the strip on the inside of the inboard wing rib.

Repeat this procedure to create the bracing tapes between the wing rear spar and trailing edge.

Repeat this procedure to add the bracing tapes to the other side of the lower wing.

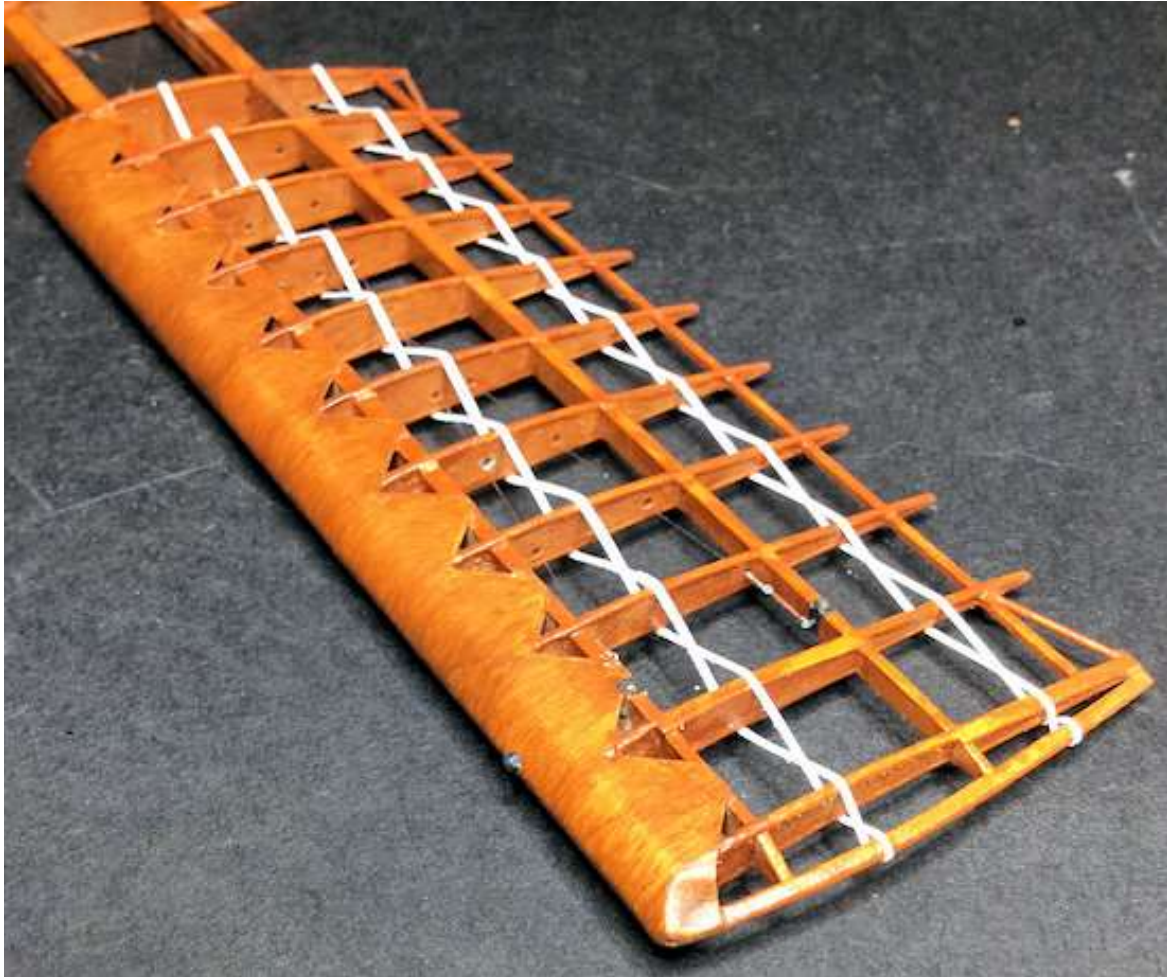

Trailing edge support wire:

Cut a long length of 'Infini Model' Medium 1:32 Aero Black Rigging (0.135 mm).

Secure one end of the line to the trailing edge of the lower wing outboard wing rib, using thin CA adhesive.

Pull slightly on the line to tension it then secure it to the trailing edge of the next inboard wing rib.

Repeat this procedure until the line is attached to all of the wing ribs.

Cut away excess line from the inside edge of the innermost wing rib.

Repeat this procedure to add a trailing edge line to the other lower wing.

12. Sealing the completed wing assembly:

Seal the wing assembly by airbrushing with 'Alclad' Light Sheen (ALC-311) mixed with a small amount of 'Tamiya' Smoke (X19).

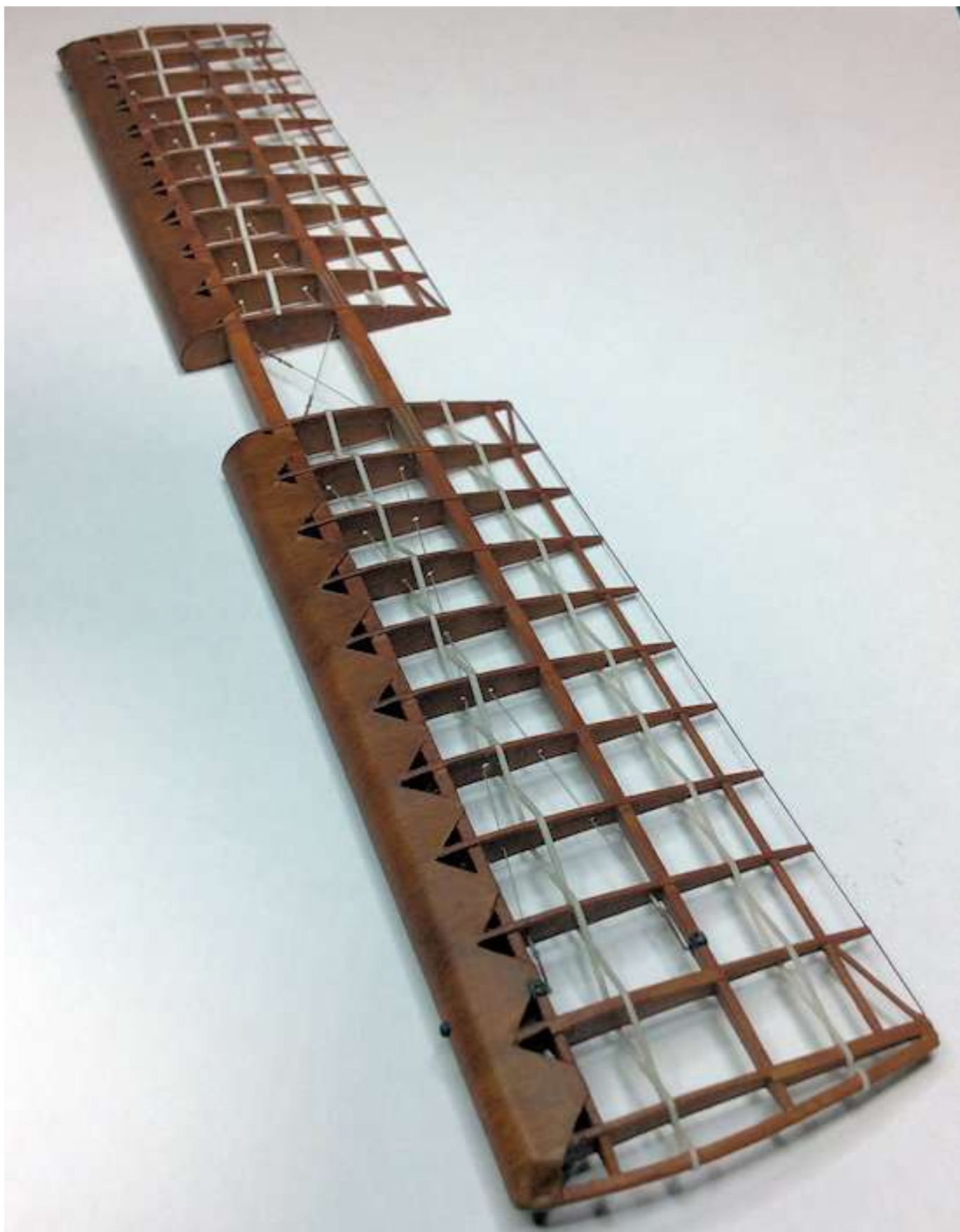

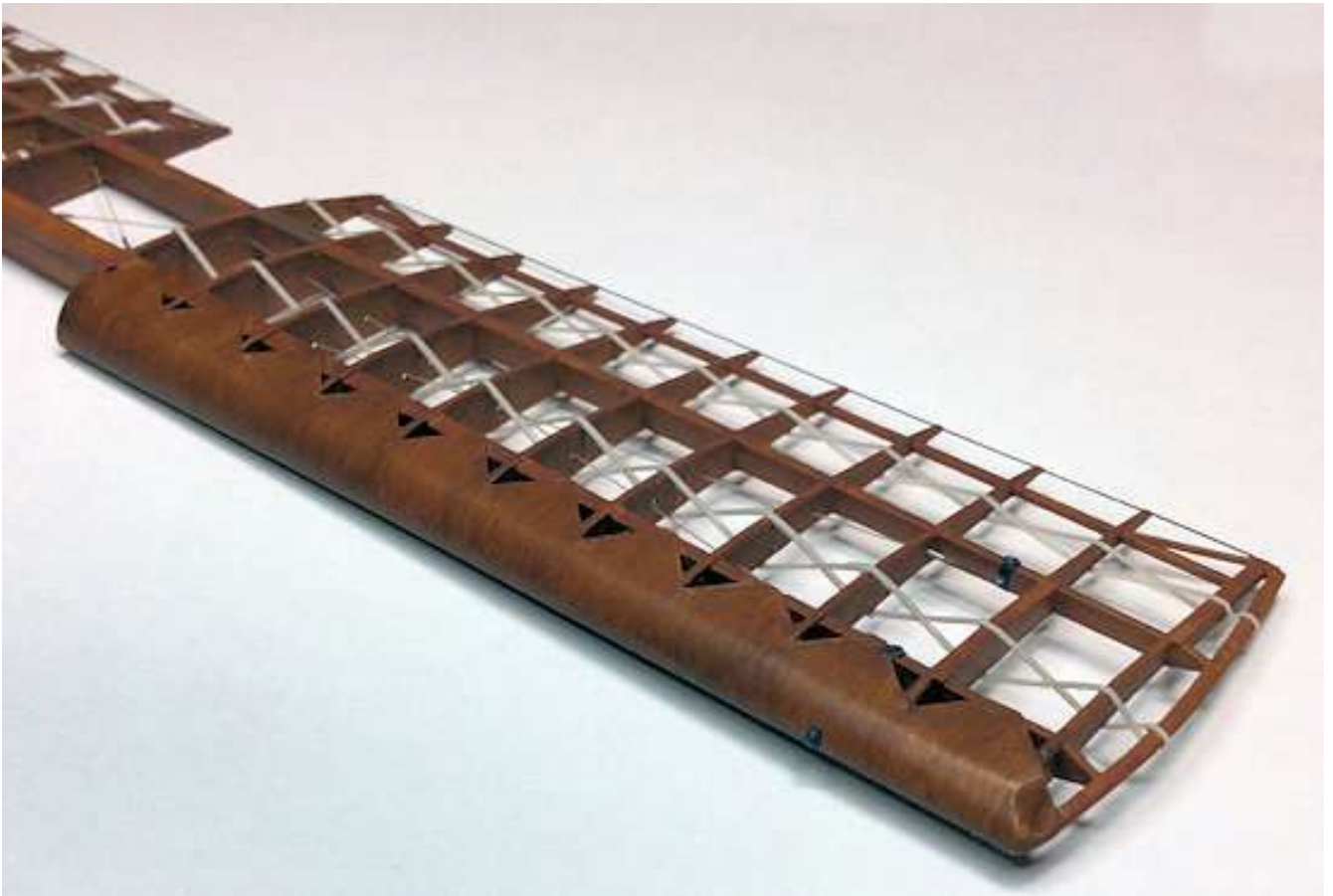
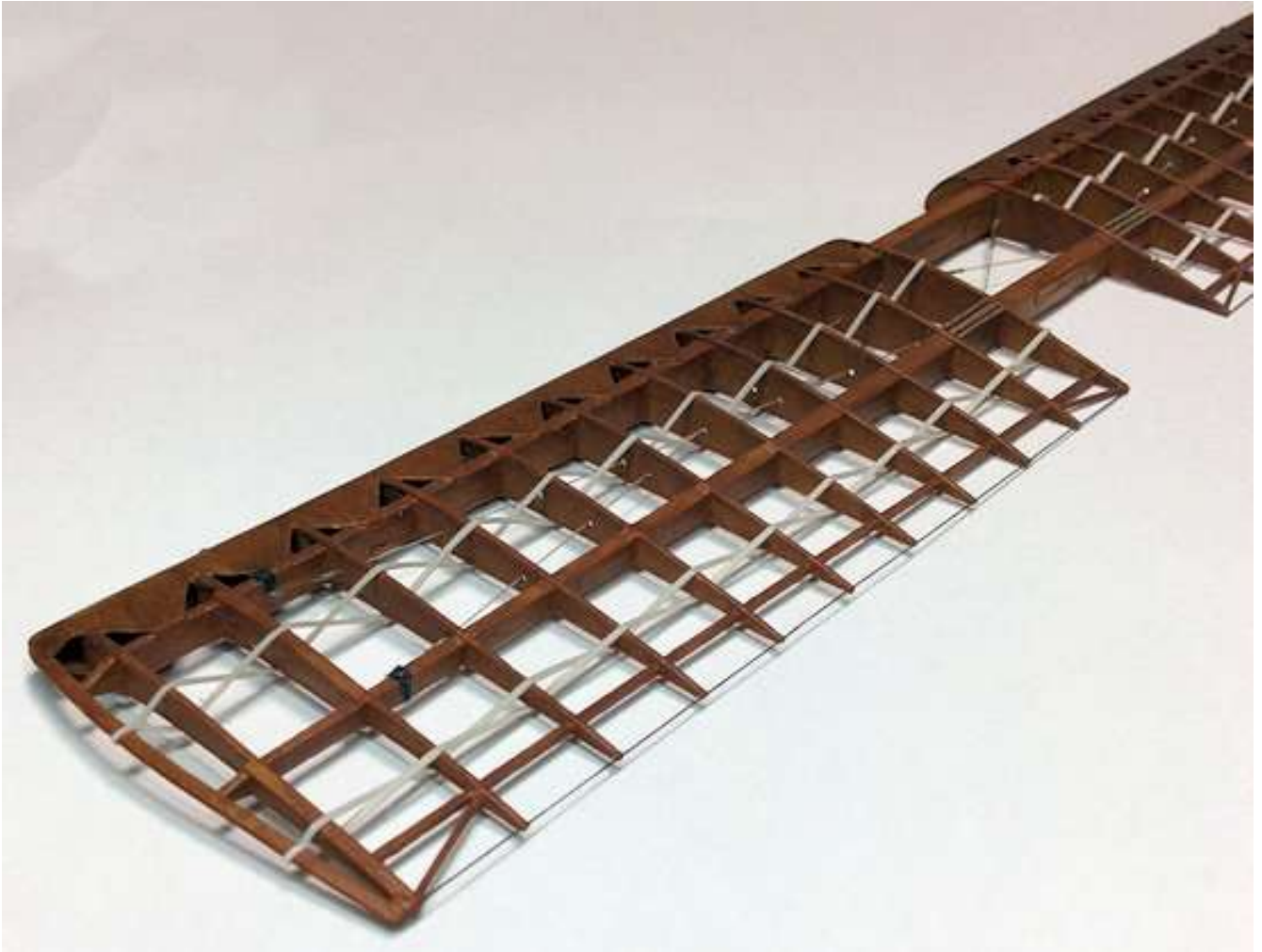

Wing support struts - attachment points:

NOTE: *The 3D printed wings have pre-molded holes for attaching the outboard wing struts, but these are too small in diameter and not deep enough to provide adequate support for the outboard struts. However, due to the brittleness of the acrylic material and the fact that the wing spars are thinner than those in the upper wing, great care needs to be taken when drilling out the strut locations. The only alternative is to modify the location stubs on the kit supplied wing struts to fit the existing locations, but doing this this may weaken the strut location stubs.*

NOTE: *In the following step, take great care when drilling out the location holes. Use only light pressure on the drill and regularly clear the drill and hole of acrylic swarf. **If you try to drill directly to 0.8 mm, the acrylic will shatter.***

Using drills stepping up in size by 0.1 mm, carefully drill out the four outboard wing strut location holes, starting at 0.5 mm diameter up to 0.8 mm diameter.

Carefully scrape or sand the bottom locating stubs on the outer wing struts until they fit the 0.8 mm drilled holes. This may require shortening the length of one or both stubs.

Fitting the lower wing:

The 3D printed wing is intended to fit into the lower fuselage frame, which is the kit supplied parts. However, I found that the front and rear wing spars did not fit fully into the fuselage frames and also, the pre-molded holes in the fuselage frame for locating the single wing support struts were partially covered by the wing. Therefore small areas of the rear wing spar and inboard wing ribs needed to be 'relieved' to allow the wing to fit correctly and leave access to the wing strut locating holes.

File a small recess into both sides of the rear wing spar. These should be on the top, rear corner, close to the inboard wing ribs.

File a small recess into both inboard wing ribs. These should be across the top of the wing ribs, just forward from the wing front spar.

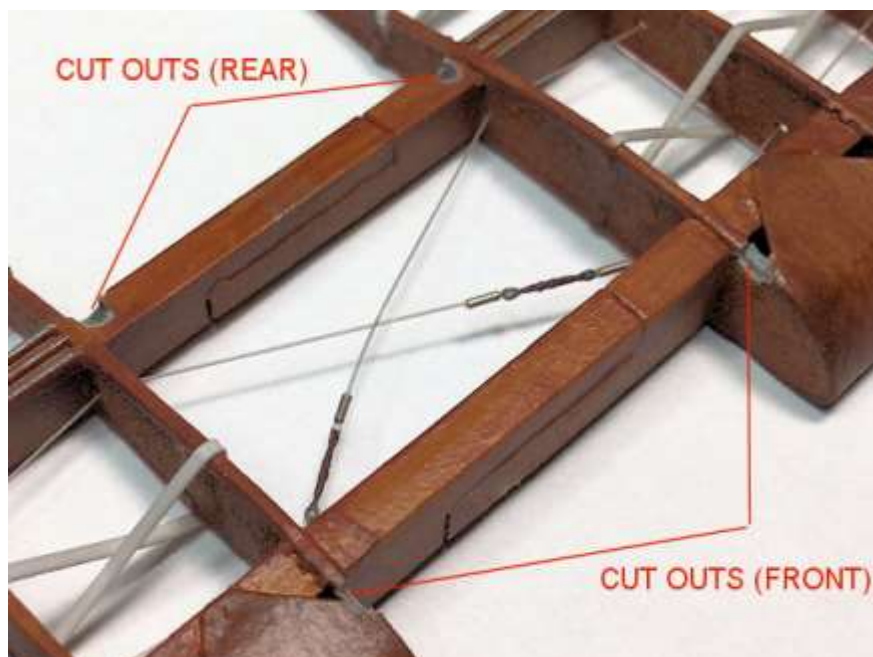

Test fit the lower wing into the fuselage and ensure the fit is correct.

Note the contact areas that should will be used to apply the adhesive.

NOTE: *Although CA adhesive has strength when set, it can tend to separate under certain conditions. Therefore I chose instead to a two part epoxy adhesive 'Araldite'.*

Mix equal small amounts of the 'Araldite' two part epoxy adhesive.

Carefully apply the adhesive to the various contact areas and locate the lower wing into the fuselage.

Leave the adhesive to fully set.

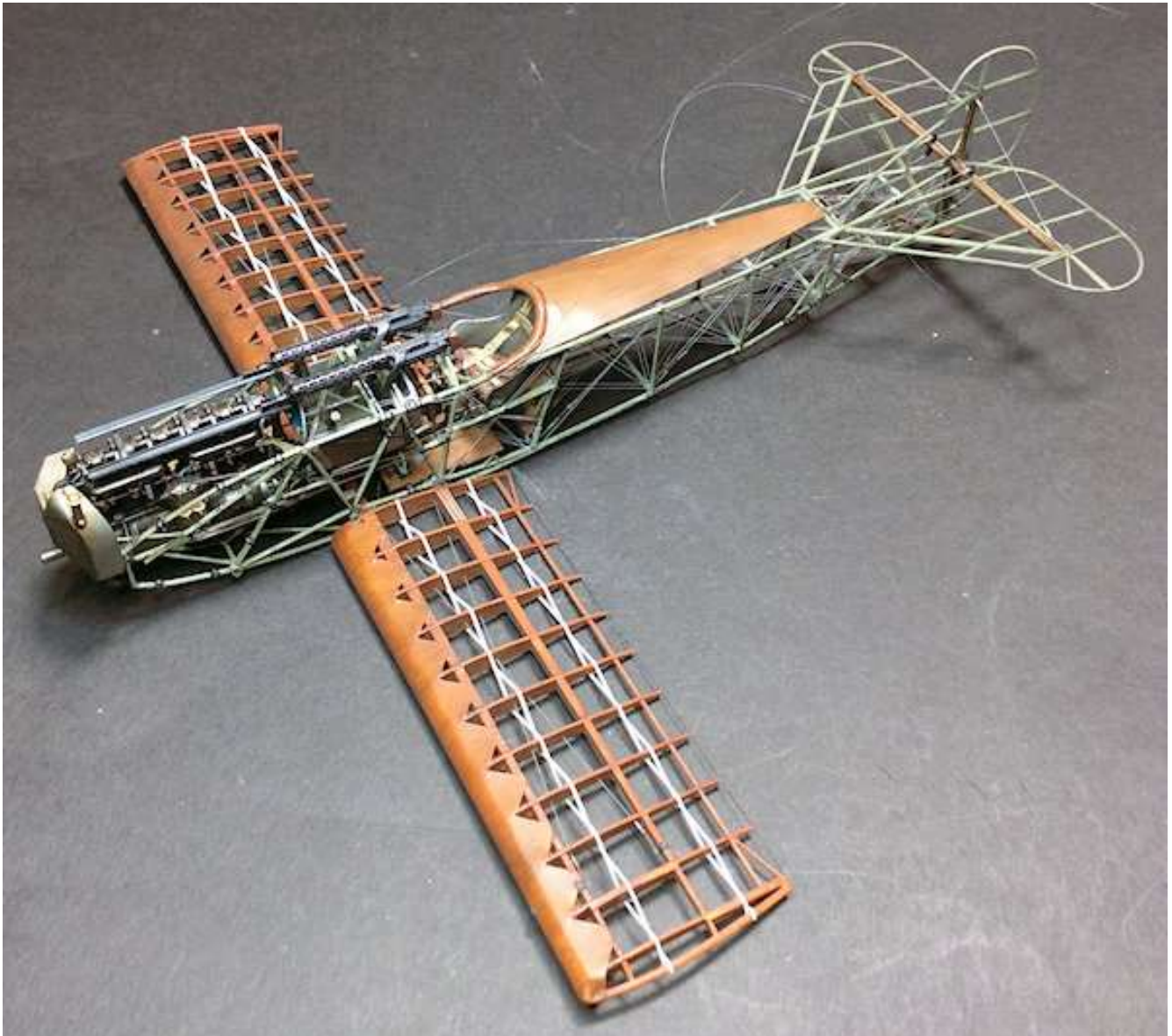

PART 10 - UNDERCARRIAGE ASSEMBLY

As there is no 3D printed undercarriage assembly available, it will need to be created by 'scratch' building techniques.

The undercarriages was attached to the fuselage by a pair of inclined struts, fitted to the axle box structure and were attached to the forward side frames of the fuselage. The two rear struts were fixed to the side frames adjacent to the front spar of the lower wing. There were six equally spaced ribs, similar to those of the wings, that spanned the undercarriage fairing. These ribs were supported by tubular front and rear 'spars' in addition to the axle box structure. Normally the fairing was covered in plywood but as this is a 'skeletal' model, this covering will not be included. The axle ran through the axle box structure and terminated at each end in a 'bungee' wrapped suspension unit. Attached to the axle ends were standard spoked wheels, which were normally fitted with linen covers.

The construction of the undercarriage assembly will require the following parts to be made:

- Axle.
- Six aerofoil ribs.
- Two torsion tubes.
- Rectangular axle box.
- Four support struts.
- 'Bungee cord' suspension units.

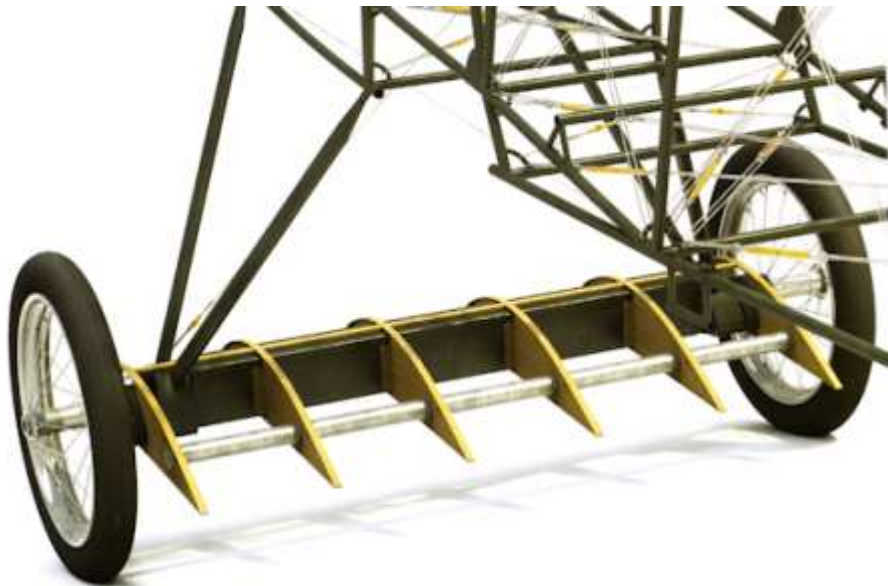

NOTE: *The kit supplied undercarriage parts will be used as templates and guides for constructing the assembly.*

Axle block:

From 1.0 mm thick plastic card, cut four strips 48 mm long and 6 mm high.

Cement the four strips together.

Once set, file or sand the block to 45 mm long and 5 mm height. Make sure the sides are square to each other.

Fairing ribs:

Combine the kit fairing parts (J8, J12) as a template and trace the end profile onto 0.8 mm thick plastic card.

Cut the rib shape out and file or sand the edges to match the end profile of the kit fairing parts.

At the centre line of the rib and 2.5 mm from the larger leading edge profile mark then drill a hole of 1.8 mm diameter.

From the centre of that hole and 15 mm towards the trailing edge, mark then drill a hole of 1.6 mm diameter.

Use this rib as a template to create five more ribs.

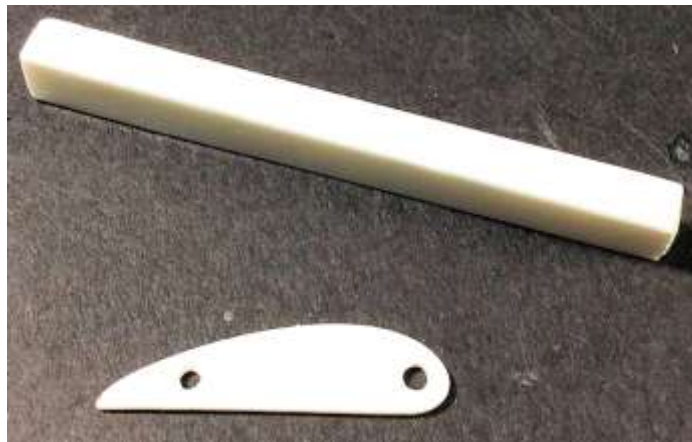

Strut support blocks:

From 0.8 mm thick plastic card, cut twelve triangles with side of approximately 5 mm and 4mm.

Cement three triangles together to create four 'support blocks'.

Once set file or sand the 5 mm sides flat.

Cement the 5mm sides of the triangles to the 5mm sides at the ends of the axle block.

Once set file or sand the bottoms of the triangles flush to the axle block.

File or sand the angled edge of the triangles flat and to the top of the axle box.

Sand a slight concave curve into the angled edges of the triangles.

'Bungee' suspension units:

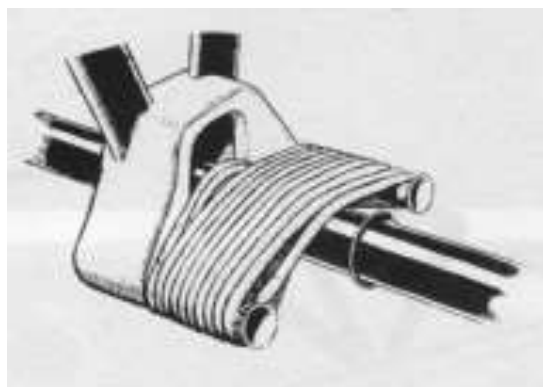



Cut off the 'bungee' suspension units from the ends of the kit supplied axle (A30).

Cut off the stub axle from each suspension unit.

Mark the centre of where the stub axle was and drill a hole of 1.2 mm diameter through the suspension unit.

In the centre of the axle block and 2 mm from the bottom, drill a hole of 1.2 mm into both ends of the axle box and as far as possible. Make sure the drill is kept aligned with centre of the axle box.

Cut two lengths of 'Albion Alloys' 1.2 mm diameter brass tube (MBT12), long enough to reach the ends of the drilled holes and with the suspension units slid onto the tube, flush with the outside of the suspension units.

Cut two lengths of 'Albion Alloys' 0.8 mm diameter brass tube (MBT08) the same length as the 1.2 mm tubes, less 1.5 mm.

Insert the 1.2 mm tubes fully into the drilled holes in the axle box.

Insert the 0.8 mm tubes fully into the 1.2 mm tubes.

Cut two lengths of 'Albion Alloys' 0.5 mm diameter brass rod (BW05) long enough to be able to be inserted fully into the 0.8 mm tubes, with 4 mm protruding.

Insert the 0.5 mm rod into the 0.8mm tube and that tube into the 1.2 mm tube.

Insert the 0.5 mm rod into the 0.8 mm tube, then that tube into the 1.2 mm tube.

Make sure the tubes are flush at one end then secure together using thin CA adhesive.

Insert fully the tube assemblies into the pre-drilled 1.2 mm holes in the ends of the axle box.

Secure in position using thin CA adhesive.

Slide the suspension units onto the tube assemblies and secure using CA adhesive on the tubes and cement between the units and axle box ends.



Fitting the fairing ribs:

Select two rib frames as the outside ribs and mark the position of the axle suspension units.

Carefully drill then cut out and sand an aperture, sufficiently large enough to fit over the suspension units.

On the remaining four ribs and from the bottom side, mark the outline of the axle block.

Carefully drill then cut out and sand an aperture, sufficiently large enough to fit over the axle box.

Cut a length of 'Albion Alloys' 1.8 mm diameter tube (MBT18) to span between the two suspension units. The ends of this tube should be half way across the 'bungee' cords on the suspension unit.

Cut a length of 'Albion Alloys' 1.6 mm diameter tube (MBT16) to the same length.

Slide the six ribs onto the two tubes (larger tube at the leading edge holes) and with the two ribs with apertures on the outside.

Position the ribs and adjust the rib cut outs as necessary so the ribs sit correctly and the two tubes are horizontal.

Test fit of undercarriage parts - wheels temporarily fitted

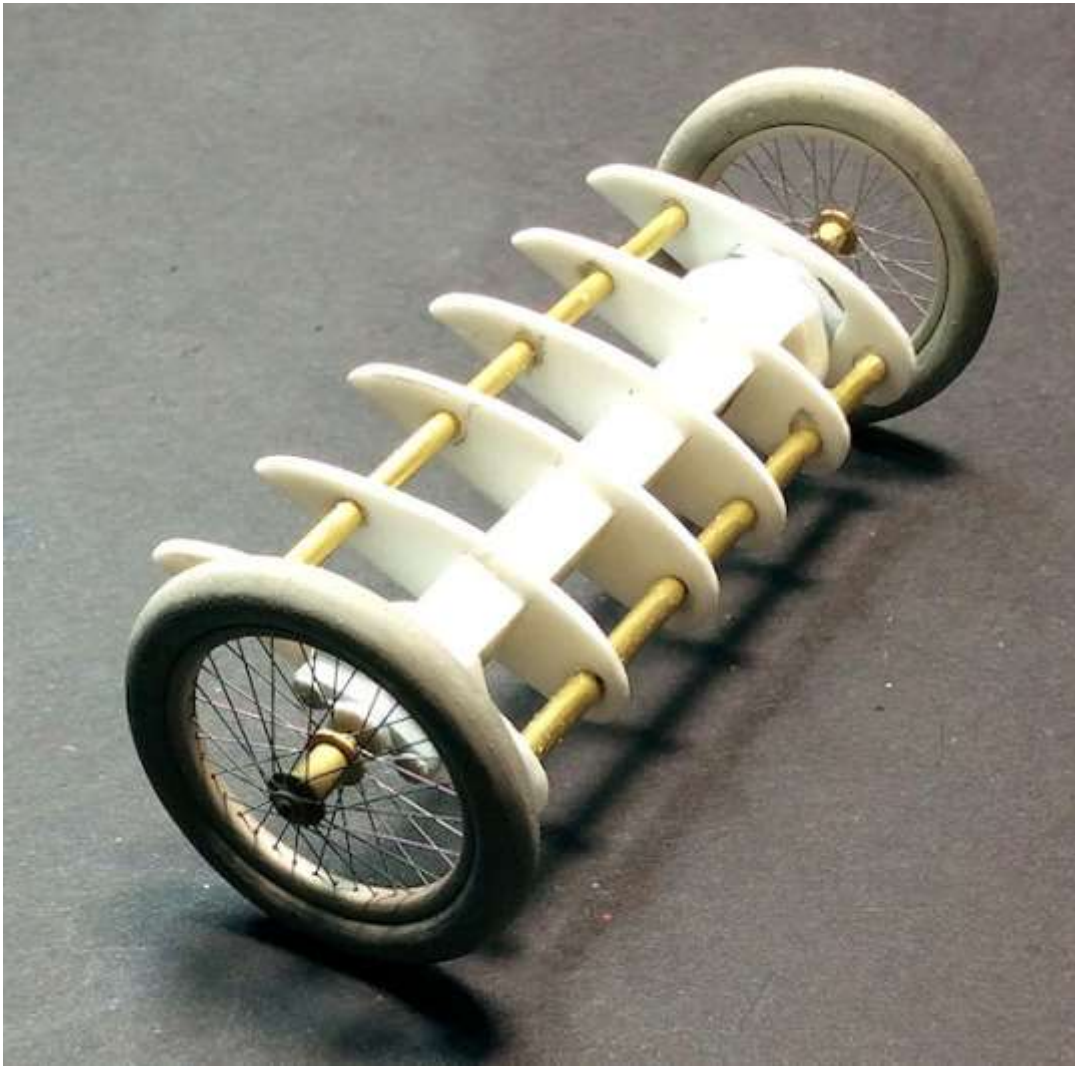

Painting and assembly:

Cut a long length of 0.5 mm diameter Styrene rod.

Airbrush prime Styrene rod and all undercarriage parts using Grey-758.

Airbrush a base coat of 'Alclad' Black Base (ALC-305) over the axle box assembly.

Airbrush 'Alclad' Steel (ALC-112) over the axle box assembly and the two brass torque tubes.

Airbrush only the axle box with a very light coat of 'Tamiya' Dark Green (XF61), such that the Steel undercoat slightly shows through. Once dry very lightly scuff the surface with a fine sand paper to create 'scratches and wear' marks.

Brush paint the 'bungee' suspension cords with 'Tamiya' Buff (XF57).

Airbrush a base coat of 'Tamiya' Buff (XF57) over the Styrene rod and the six ribs.

Apply your desired wood effect to the Styrene rod and six ribs (refer to Part 2 of this build log) - I used 'DecoArt' Burnt Umber.

Airbrush the Styrene rod and six ribs with a light coat of 'Alclad' Light Sheen (ALC-311) with a small amount of 'Tamiya' Clear Orange (X26) added.

NOTE: *Due to build up of primer/paint, the various parts may need to be adjusted to fit. The pre-drilled holes in the six ribs and their axle box cut outs may need to be 'opened up'.*

Slide the six ribs onto the two torque tubes, with the larger tube at the leading edge holes, and with the two ribs with apertures on the outside.

Position the ribs so that the end ribs are half way across the 'bungee' suspension cords and the inner four ribs are equally spaced along the axle box. Make sure the two torque tubes are horizontal and the six ribs are correctly aligned.

Cement the inner four ribs to the axle box.

Secure the two torque tubes to all six ribs using thin CA adhesive.

Cut the prepared Styrene rod into sections that fit on top of the axle box and between the six ribs.

Cement these in position on top of the axle box and between the ribs.

Undercarriage cross bracing:

The undercarriage assembly was braced with single crossed cables. These cables were attached, with turnbuckles, to the top of the axle box between the undercarriage support struts. The cables were then crossed to be attached to the forward strut attachment locations on the fuselage side frames.

NOTE: *The installed cross bracing cables will be attached to the fuselage during the fitting of the undercarriage assembly in Part 12 of this build log.*

Drill a 0.3 mm diameter hole into the top, end of the axle box, forward from the wood cross strip and slightly inboard from the strut mounting blacks. The hole should be drill at an inward angle so the installed cross brace cable aligns with the top of the opposite forward undercarriage strut.

Cut a short length of 'Albion Alloys' 0.4 mm Nickel-Silver tube (NST04).

Prepare a 'Gaspatch' 1/48th scale turnbuckles (one end type) by breaking it off the base and filing the tag away (diamond file).

Cut a long length of 'Stroft' mono-filament (0.08 mm diameter).

Thread the free end of a line through a cut tube then through the 'eye' end of a turnbuckle.

Loop the cable back through the tube and tension the free end of the cable to draw the tube up to, but not touching the turnbuckle.

Make sure the tube is not in contact with the turnbuckle 'eye' end.

Secure the tube to the line using CA adhesive.

Carefully trim away the exposed lines leaving just the tube.

Insert the shank of the turnbuckle into the pre-drilled hole and secure in position using thin CA adhesive.

Brush paint the body of the turnbuckle with a 50/50 mix of 'Tamiya' Copper (XF6) and Hull Red (XF9).

Repeat this procedure to create and install the opposite bracing cable.



Undercarriage support struts:

The kit supplied struts are designed to fit into the top of the kit undercarriage fairing. As this model has no covering over the fairing ribs, it is necessary to make the struts to the correct length so that they attach to the end blocks on the axle box.

Front struts:

Dry fit the kit supplied forward undercarriage struts into their locations in the kit supplied top undercarriage fairing. *Use this assembly as a guide to the angles of the installed struts.*

In the fuselage locations for the undercarriage forward struts, drill a 0.6 mm diameter hole horizontally through the bottom of the strut locations.

Cut two lengths of 'Albion Alloys' 1.4 mm diameter brass tube (MBT14) of 29 mm length.

Cut two lengths of 'Albion Alloys' 0.5 mm diameter brass rod (BW05) of 39 mm length.

File one end of each of the 1.4 mm tubes at a slight angle so when it is placed against the forward sloping face of the angled mounting block on the axle box ends, it matches the alignment of the kit assembled struts.

Slide the 0.5 mm rod through the tubes leaving 5 mm protruding from each end.

If possible, soft solder the rod in the tubes. Otherwise CA adhesive can be used to secure the rod in the tubes.

On the trailing edge at the fuselage end of the struts, file or sand a chamfer the same as the kit supplied struts.

In the forward sloping face of the angled mounting block on the axle box ends, 2 mm from the top edge, drill a hole of 0.6 mm diameter and at the same inward and forward angle to match with the kit assembled struts.

Insert the 0.5 mm rod on the bottom of the struts fully into the drilled holes and holding the struts, gently bend them to the angle that matches the kit installed forward struts.

At the fuselage end of the struts, bend the 0.5 mm brass rod down and inwards so they will enter the pre-drilled holes in the fuselage forward strut locations.

Test fit the struts into the undercarriage assembly and the fuselage forward strut locations. Make sure the undercarriage assembly and struts sit correctly when compared to the kit assembly when it is temporarily fitted. If necessary, gently bend the struts to fit.

Secure the two undercarriage forward struts into the undercarriage assembly using CA adhesive.

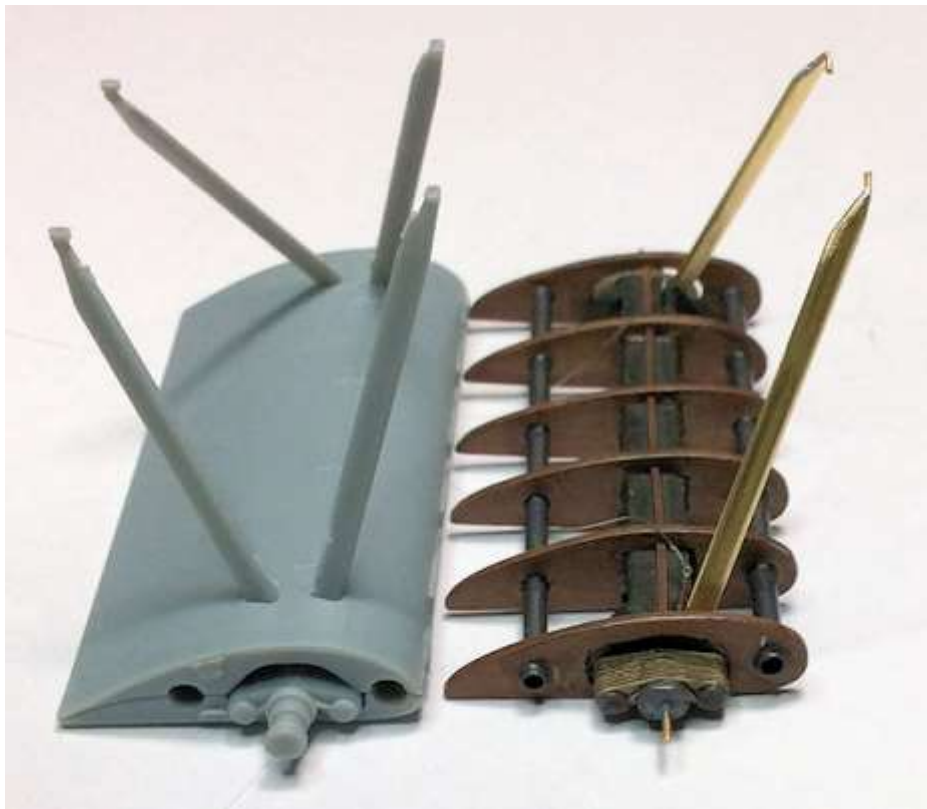

Rear struts:

Creating the two rear undercarriage struts follows the same procedure used for the two front struts, with the following differences:

1. To determine the length required for the rear struts, first locate the two front struts into the pre-drilled location holes, so the assembly is able to 'swing' on the struts. Then cut a length of 0.5 mm rod or similar and bend the ends such that a 'guide' for the rear struts is created. Use this as a guide to cutting the 1.4 mm tube (between the bends).
2. Drill a 0.6mm hole into the centre, underside of the wing front spar, in line with the bottom tube of the fuselage side frames. These will be used to locate the 0.5 mm rod in the top of the rear struts.

3. The protruding 0.5 mm rod at the top of the rear struts needs to be bent vertically so it can be inserted into the pre-drilled location holes.



Brush prime the four installed struts with Grey AK-758.

Brush paint the four struts using 'Tamiya' Grey Green (XF76).

Seal the struts by airbrushing with 'Alclad' Light Sheen (ALC-311).

Refer to Part 3 of this build log and apply the 'Flory' clay wash of your choice for to the struts - I used Dark Dirt for the weathering.

Seal the weathered struts by airbrushing with 'Alclad' Light Sheen (ALC-311).

Locate the four struts into their location holes in the wing front spar and forward fuselage frames then secure in position using CA adhesive.

Slide a cut 0.4 mm Nickel-Silver tube onto the free end of the two bracing cables.

Pass each line diagonally across the front struts and around the forward strut location.

Gently pull the line taut and secure them in position with CA adhesive.

Cut away any excess line.

Slide the two 0.4 mm tubes up to the strut locations and secure in position using CA adhesive.



PART 11 - UPPER WING

Upper wing and struts:

The 3D printed upper wing consists of the left and right wings, wing centre section and the two ailerons. The three part wing is joined using 'butt' jointing. Both wings are molded with access holes through wing ribs to allow the fitting of cross bracing cables and holes for routing the aileron control cables. Although detailed the wings are lacking certain detail:

Plywood 'saw tooth' leading edge panels.

Bracing cable attachment points.

Leading edge 'bump stops' (used to protect the wings during stacking or transporting the wings when removed from the aircraft).

Optional: Wing rib bracing tapes.

Aileron twin and single control cable pulleys (for routing the aileron control cables).

Trailing edge support wire (for attaching the linen covering).

NOTE 1: *As with the previously described lower wing, Fokker D.VII aircraft were fitted with bracing across the wings between each of the wing ribs and I decided for this build to take up the challenge of representing the earlier bracing tape bracing. If desired the original 3D printed strip wood bracing can be retained, along with that on the lower wing, as this would be an easier build option.*

The upper wing is similar in construction to that of the lower wing, apart from being in three sections and having the ailerons and associated control lines and pulleys fitted. *The general construction and finish required can be achieved by following the same procedures as detailed for the lower wing in Part 9 of this build log (pages 128 to 138).*

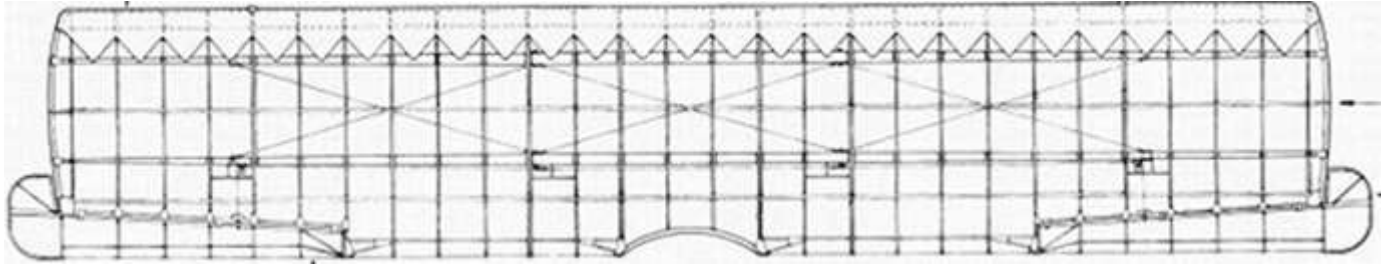

The following construction details differ from that of the lower wing.

- Wing section 'butt' joints.
- Fitting of ailerons.
- Fitting of aileron control line pulleys.

Wing section 'butt' joints:

The 3D printed wing sections are intended to be joined by securing them together at the flat wing rib surfaces, essentially a 'butt joint'. Although the wing sections are, by design, light weight and will be supported by the wing struts, I still felt that additional strength should be added at the wing butt joints. Although CA adhesive has strength when set, it can tend to separate under certain conditions. Therefore I chose instead to a two part epoxy adhesive 'Araldite'.

NOTE 1: *In the following step, make sure the wing sections are aligned at the 'butt joints'.*

NOTE 2: *The forward edges of the wing ribs at the 'butt joints' are slightly spayed, probably due to the 3D printing process. These need to be clamped together whilst the adhesive sets.*

NOTE 3: *When joining the wing sections, make sure the areas around the rigging holes in the wing ribs are kept clear of adhesive.*

NOTE 4: *Take care when handling the upper wing parts as the acrylic material used is very fragile, particularly the front of the wing ribs, which are unsupported.*

INFORMATION ONLY: *There are four double thickness wing ribs in wing centre section. These are the third rib in from each side and the outer ribs, once joined to the wing outer sections.*

Mix equal small amounts of the 'Araldite' two part epoxy adhesive.

Carefully apply the adhesive to the outer surface of one of the outer wing ribs of the wing centre section.

Join the centre section to the applicable outer wing section, making sure the rib profiles at the join are aligned.

Clamp the wing ribs together until the adhesive sets.

Repeat the procedure to attach the opposite outer wing section to the centre section.

Once the adhesive has fully set, carefully file or sand away any excess adhesive around the wing rib 'butt joints'.

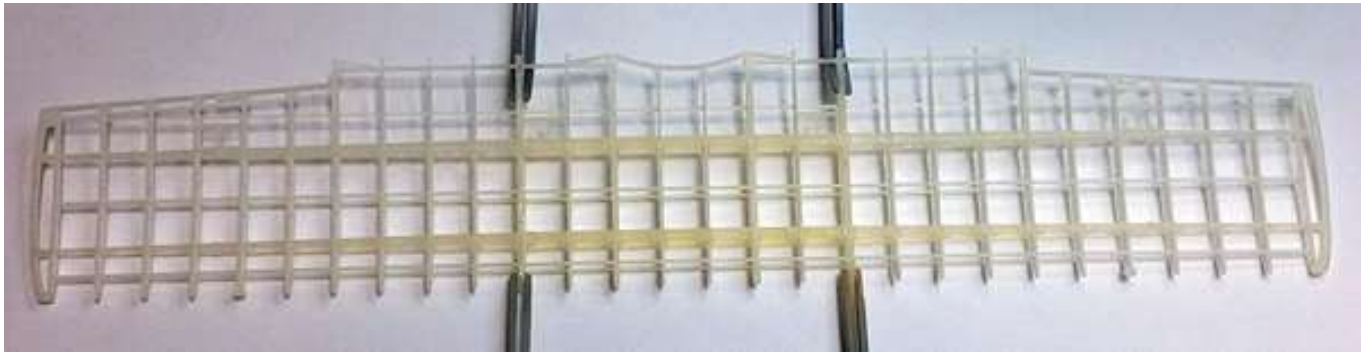

Optional - Wing rib bracing tapes:

To prepare for adding wing bracing tapes, as replacements for the pre-molded 'strip wood' struts, the assembled upper wing needs to be modified.

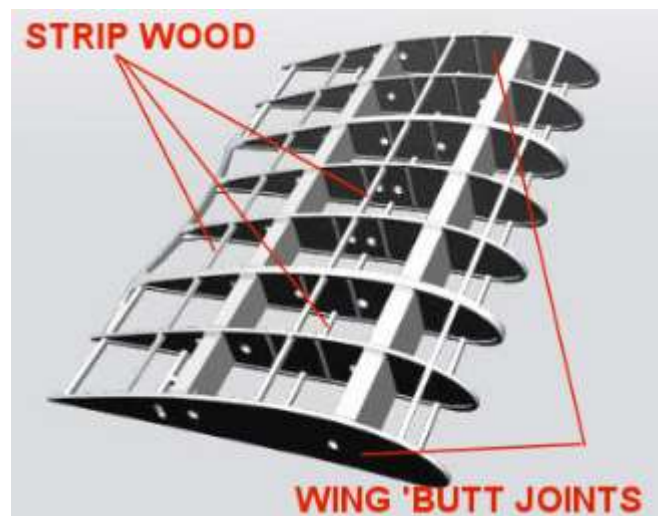
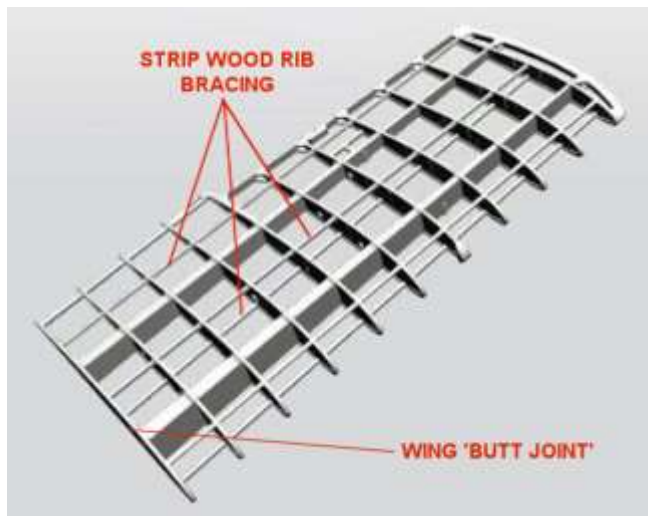

Carefully cut away the pre-molded 'strip wood' bracing struts from across the upper wing assembly.

Carefully file or sand away any stubs of material left on the wing ribs.

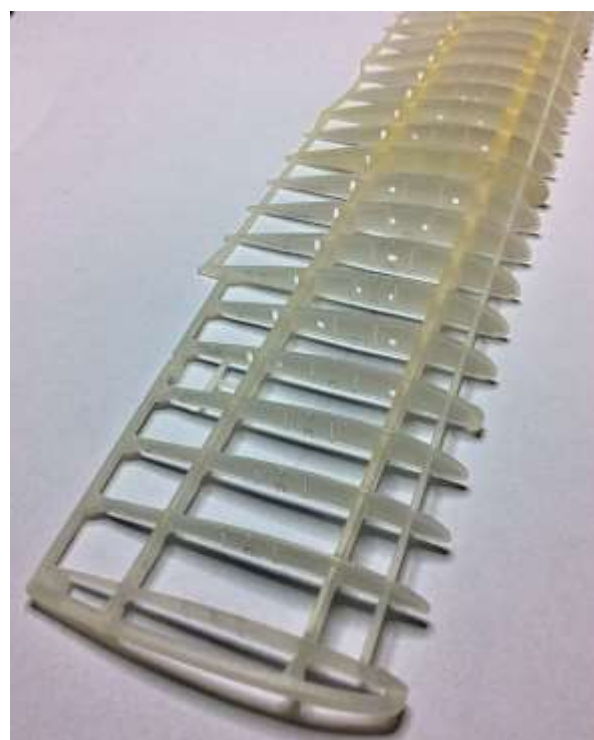

Wing support struts - wing attachment points:

NOTE: The 3D printed wings have pre-molded locations for attaching the wing struts in the form of rectangular recesses for the inboard struts and holes for the outboard struts. The holes for the outboard struts are too small in diameter and not deep enough to provide adequate support for the outboard struts. However, due to the brittleness of the acrylic material, great care needs to be taken when drilling out the strut locations. The only alternative is to modify the location stubs on the kit supplied wing struts to fit the existing locations, but doing this may weaken the strut location stubs.

File or sand the location rectangles on the top of both tripod struts and single rear struts so that they fit into the pre-molded recesses in the underside of the upper wing.

NOTE: In the following step, take great care when drilling out the location holes. Use only light pressure on the drill and regularly clear the drill and hole of acrylic swarf. **If you try to drill directly to 0.9 mm, the acrylic will shatter.**

Using drills stepping up in size by 0.1 mm, carefully drill out the four outboard wing strut location holes, starting at 0.5 mm diameter up to 0.9 mm diameter.

Wing support struts - fuselage attachment points:

The two tripod wing struts are attached to the fuselage side frames as follows:

Forward strut - cemented onto the top of the horizontal tube in the side frame, towards the front of the engine.

Centre strut - cemented into its location recess above the location for the forward under carriage strut.

Rear strut - cemented into its location hole at the top of the side frame, at the forward corner of the fuel tank.

The single rear wing strut is cemented into its location hole at the bottom of the side frame, forward of the wing front spar.

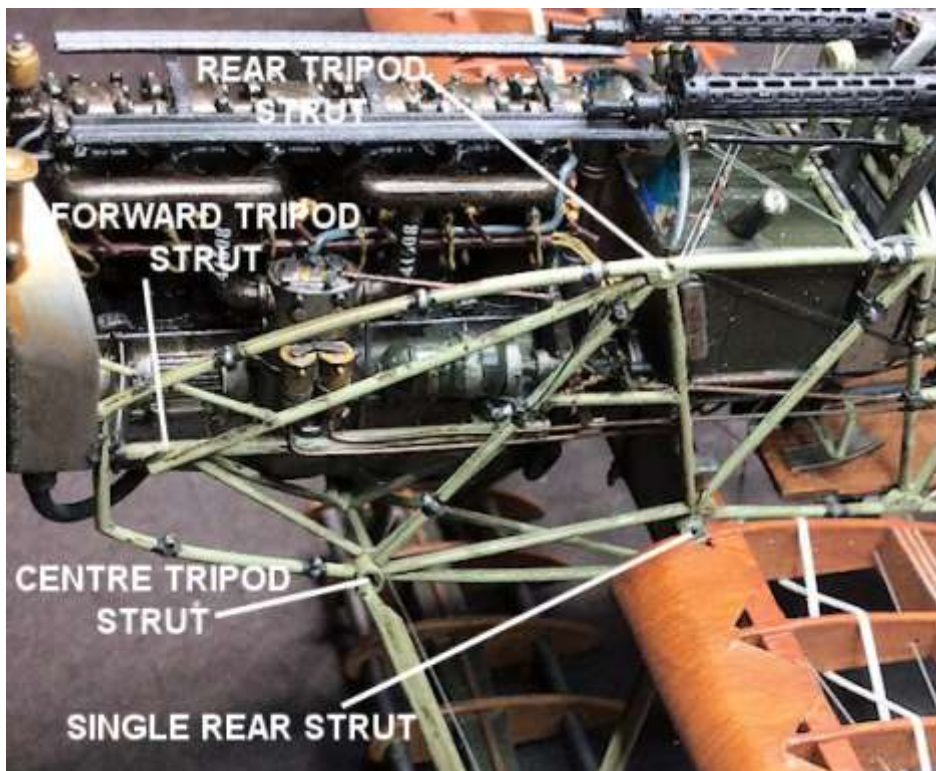

Check fit the tripod centre and rear struts and the single rear strut into their location holes and make sure there is unrestricted access and the holes will accept the strut locating stubs.

Where necessary, file or sand the locating stubs on the tripod central and rear struts to allow them to fit in the existing holes.

If necessary create extra clearance at the wing leading edge to allow the tripod rear strut to fit and

Where necessary, increase the hole size for the central tripod strut to allow the strut to fit.

Paint prime all wing struts with Grey AK-758.

Paint all wing struts using 'Tamiya' Grey Green (XF76).

Seal the struts by airbrushing with 'Alclad' Light Sheen (ALC-311).

Refer to Part 3 of this build log and apply the 'Flory' clay wash of your choice for to the struts - I used Dark Dirt for the weathering.

Seal the weathered struts by airbrushing with 'Alclad' Light Sheen (ALC-311).

Cross bracing attachment points:

Drill a 0.5 mm diameter hole through the front and rear wing spars (from front to rear) at the wing strut mounting points. These will be used for attaching the cross bracing cables.

Plywood 'saw tooth' leading edge fairings:

At this stage the 'saw tooth' leading edge plywood panels should be created.

First obtain a copy of the wing structure, such as that on page 34 of 'Fokker D.VII - Anthology 1', published by 'Albatros Publications Ltd 1997.

Using PC software, scan the page and then increase the size of the image and print the image onto paper.

Overlay the wing assembly over the print to ensure the wing structure aligns with the print. If necessary adjust the print size until this is achieved.

NOTE: *Although in reality the upper and lower wings were 'single piece' constructions, I chose to make the 'saw tooth' leading edge fairings for the upper wing as three sections, in order to avoid difficulties with fitting a single length to the wing.*

NOTE: *The wing section joints are at the outer wing ribs of the centre section, where the 'butt' joints are to the wings outer sections.*

Follow the same procedure as used for the lower wing to create the leading edge 'saw

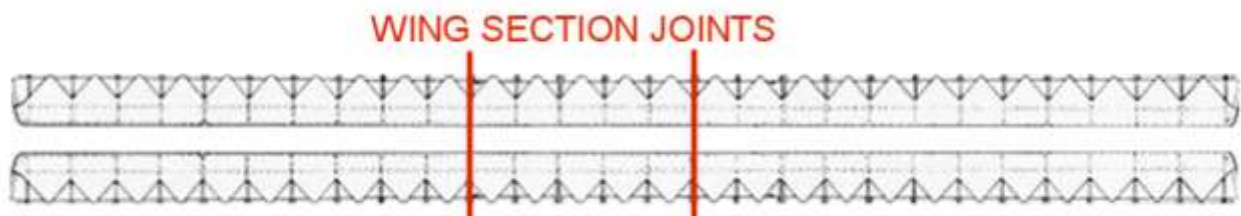

tooth' panel, but as three sections (left and right wing and centre section).



Apply the basic finish to the wing assembly as done for the lower wing.



Leading edge 'bump stops':

Follow the same procedure for adding a 'stacking pad' to each side of the upper wing leading edge, as detailed for the lower wing.

Wing cross bracing cables:

NOTE: *The upper wing centre section has wing ribs, unlike the centre section of the lower wing. The turnbuckles on the cross bracing wires are positioned at the forward corners inside the centre section outer ribs.*

Follow the same procedure for fitting the cross bracing wires as was detailed for the lower wing.

Optional - wing rib bracing tapes:

Follow the same procedure for fitting the wing rib bracing tapes as was detailed for the lower wing.

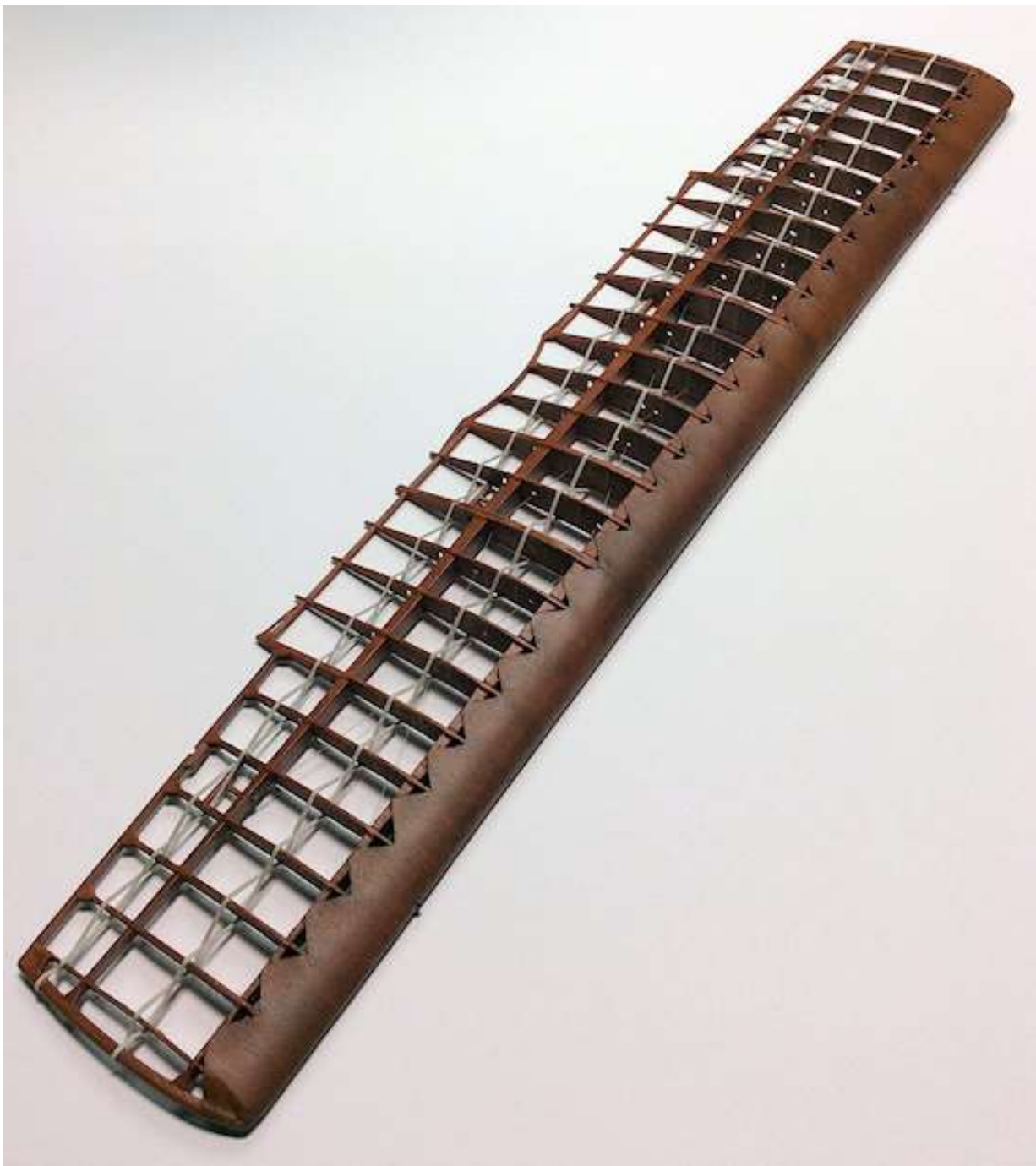

Ailerons:

NOTE: Once the two 3D printed ailerons are separated from the support frame, some slight bow across each aileron may be seen. **Do not** try to bend the ailerons straight as they may break. The ailerons are flexible enough to locate flat in their mounting grooves in the upper wing trailing edge.



Separate the ailerons from the mounting frame and carefully file or sand away remaining attachment stubs.

Drill a 0.2 mm diameter hole close to the each end of the two aileron control horns (D18).

NOTE: In the trailing edge of the wing, at the aileron position, is a small pre-molded indent.

Offer up the aileron to the wing trailing edge and mark the position of the 'indent' on the aileron front spar.

Fold a piece of fine sand paper and sand a slot into both the wing 'indent' and the mark on the aileron (but no too far).

Locate the recess on the aileron control horn into the sanded slot on the aileron and secure in position using thin CA adhesive.

Paint prime the two ailerons with Grey AK-758.

Paint the ailerons using 'Tamiya' Grey Green (XF76).

Brush paint the two control horns using 'Tamiya' Rubber Black (XF85).

Seal the ailerons by airbrushing with 'Alclad' Light Sheen (ALC-311).

Refer to Part 3 of this build log and apply the 'Flory' clay wash of your choice for to the ailerons - I used Dark Dirt for the weathering.

Seal the weathered ailerons by airbrushing with 'Alclad' Light Sheen (ALC-311).

Make sure the holes drilled in the two control horns are clear of primer and paint. If necessary, run the 0.2 mm drill through the holes.

Cut four long lengths of 'Stroft' mono-filament (0.08 mm diameter).

Cut four short lengths of 'Albion Alloys' 0.4 mm Nickel-Silver tube (NST04).

Thread the mono-filament through a cut tube then through a pre-drilled hole in the end of an aileron control horn.

Loop the cable back through the tube and tension the free end of the cable to draw the tube up to, but not touching the control horn.

Make sure the tube is not in contact with the control horn.

Secure the tube to the line using CA adhesive.

Carefully trim away the exposed line tag, leaving just the long line intact.

Repeat to attach a line to the three remaining control horn ends.



NOTE: *When attaching the ailerons to the upper wing, make sure the attached control lines are not trapped between the ailerons and upper wing trailing edge.*

Locate the leading edge of each aileron into the groove in the rear of the upper wing trailing edge, with the control horns fully in the sanded slots.

Holding the ailerons flat in their locating grooves, secure in position using CA adhesive.

Cut thin strips of 'Bare-Metal' matte Aluminium foil and wrap them around the upper wing trailing edge and the aileron front frame, to form the three metal hinge supports.



Aileron control pulley:

After the ailerons are fitted to the upper wing, the pulleys for the aileron control cables should be constructed.

NOTE: Two sets of the 'HGW Models' Sopwith Triplane detail set (132099) are required to make enough aileron pulleys.

Outboard pulleys:

Make two pulley brackets (6) from the photo-etch set.

Make four pulley's (7) from the photo-etch set.

Bend one side of each bracket slightly away from level. This will be the angled pulley for the bottom aileron control horns.

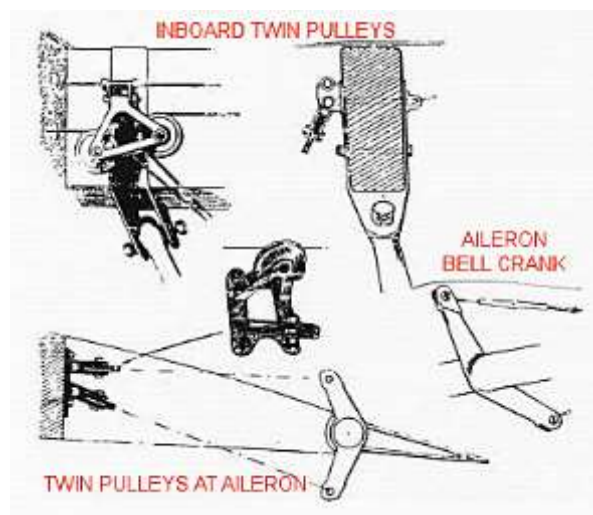

NOTE: *In the following step, make sure a small gap is left between the back of the bracket and the two pulleys when fitted.*

Add two pulleys to each bracket and secure in position using thin CA adhesive.

Brush prime then paint the brackets only with 'Tamiya' Rubber Black (XF85). Don't paint the rear face of each bracket.

Position the pulley/bracket assembly, with the angled pulley at the bottom, against the rear face of the wing rear spar and resting on the spar bottom ledge. Make sure the outer edge of the pulleys aligns with the aileron control horns.

Apply thin CA adhesive to the joint between the rear of the brackets and the wing spar.

Temporarily route the two cables from the aileron control horns around the pulleys and through the apertures pre-molded in the wing ribs.

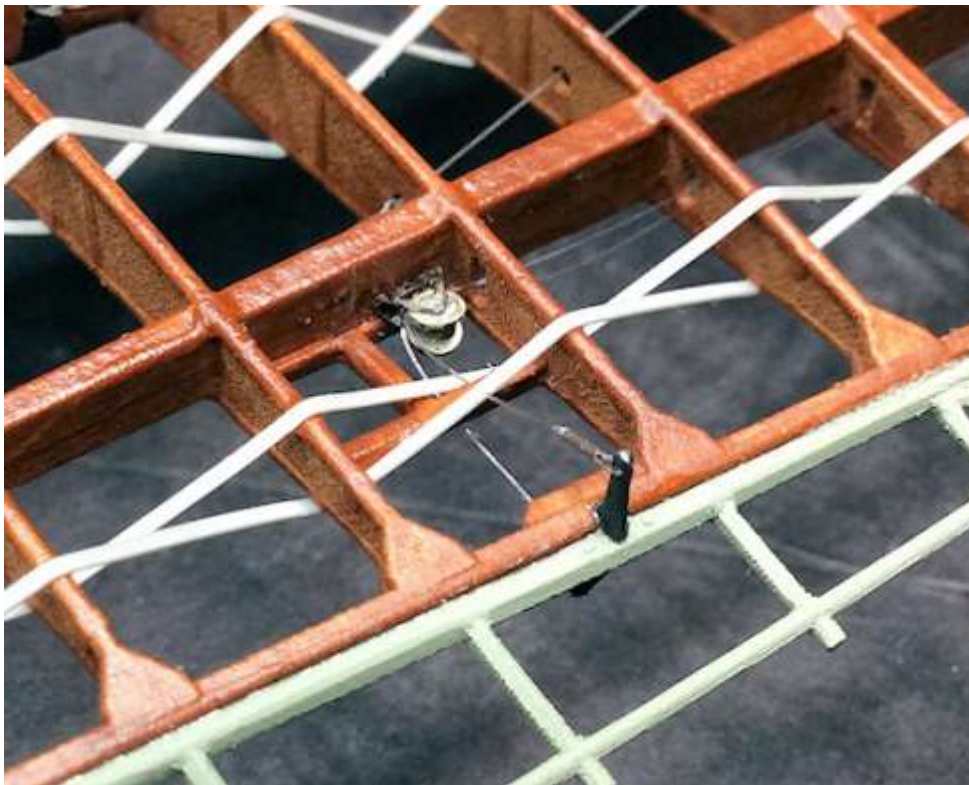

Inboard pulleys:

Cut out four pulley brackets (6) from the photo-etch set and leave them flat.

Make four pulleys (7) from the photo-etch set.

NOTE: *In the following step, make sure no adhesive gets between the rims of the two opposing pulleys, as this may block access for the control lines.*

Position a pulley at the ends of a bracket and secure using thin CA adhesive.

Position a second bracket onto the pulleys and align it with the other bracket, then secure in position using thin CA adhesive.

Repeat to create a second pulley/bracket assembly.

Brush prime then paint the brackets only with 'Tamiya' Rubber Black (XF85). Don't paint the rear face of each bracket.

NOTE: *A packing piece is required between the pulley assemblies and the rear face of the wing rear spar. This is needed to better align the control lines to the pulleys.*

From 1.0 mm thick plastic card, cut two circles to fit the rear of the pulley assemblies.

Secure the packing pieces to the rear face of the pulley assemblies.

Brush the packing pieces (not the rear face) with 'DecoArt' Burnt Sienna acrylic oil paint, to match the wing structure colour.

Position the two pulley assemblies on the rear face of the wing rear spar and between the wing ribs with the 'T-piece' bracing. The assemblies should be positioned with a slight downward tilt at the outboard pulleys.

Secure the pulley assemblies to the wing rear spar using CA adhesive.

Inboard pulleys - left side



Slide a 5 mm long 'Albion Alloys' tube of 0.4 mm diameter (NST04) onto the two top aileron control cables.

NOTE: *During the next step, position the 0.4 mm tubes on the cables over the inboard pulley assemblies.*

Using the routing diagram on the following page, thread each aileron control cable around the relevant pulleys then out through the underside of the upper wing.

Tension the cables then secure them in position on the pulleys using thin CA adhesive.

Secure the 0.4 mm tubes on top of the pulley packing pieces using thin CA adhesive.

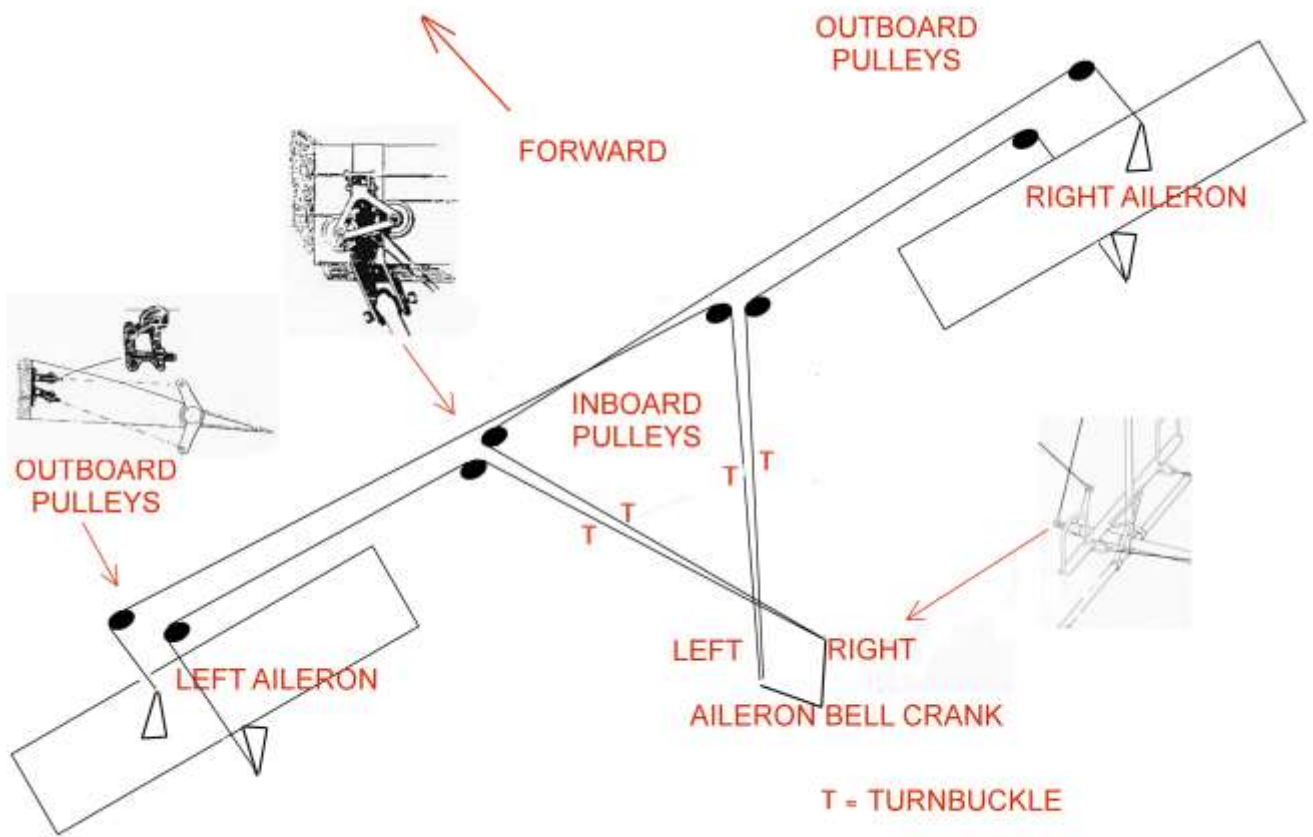

Trailing edge support wire:

Cut a long length of 'Infini Model' Medium 1:32 Aero Black Rigging (0.135 mm).

Secure one end of the line to the trailing edge of the upper wing rib, inboard from the aileron, using thin CA adhesive.

Pull slightly on the line to tension it then secure it to the trailing edge of the next inboard wing rib.

Repeat this procedure until the line is attached to all of the wing ribs, ending at the curved centre section trailing edge.

Cut away excess line from the inside edge of the innermost wing rib.

Repeat this procedure to add a trailing edge line to the other side of the upper wing.

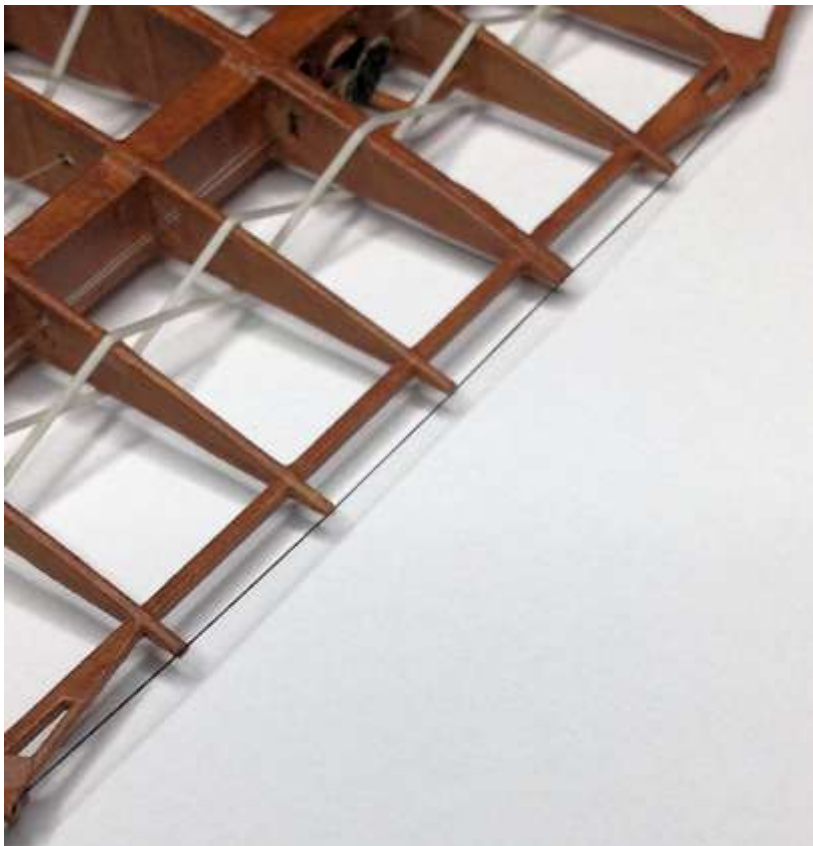

Control cable turnbuckles:

The twin aileron control cables from each side of the upper wing were connected to the cables from the cockpit (already fitted in the fuselage). They were connected by external turnbuckles located between the upper wing inboard control pulleys and the fuselage. These should be connected to the cables from the upper wing before the wing is fitted.

NOTE: *During the following steps the turnbuckles should be located on the control cables midway between the underside of the upper wing and the fuselage. They should not be fitted next to each other, but staggered on the control cables and not overlapping each other.*

Cut a short length of 'Albion Alloys' 0.4 mm Nickel-Silver tube (NST04).

Prepare a 'Gaspatch' 1/48th scale turnbuckle (Type C) by breaking it off the base and filing the tag away (diamond file).

Thread a control line through the cut tube then through an 'eye' end of a turnbuckle.

Loop the mono-filament back through the cut tube.

Position the turnbuckle on the line then slide the tube up to but not touching the turnbuckle 'eye' end.

Keeping the turnbuckle and mono-filament inline, secure the tube in position using CA adhesive.

Paint the body of the turnbuckle with a 50/50 mix of 'Tamiya' Copper (XF6) and Hull Red (XF9).

Repeat to add a turnbuckle to the remaining three control lines.



PART 12 - FINAL ASSEMBLY

Fitting the upper wing:

Make sure all of the wing strut locations in the upper and lower wings and in the fuselage are clear of paint etc and that the struts fit fully into the relevant locations.

Locate the outer wing struts into their locations in the lower wing and secure in position using thin CA adhesive.

Locate the inner wing 'tripod' struts into their locations in the fuselage with the forward strut resting on the engine bearer frame.

NOTE: *The single inner struts will be fitted later.*

Cement the 'tripod' **rear struts only** into their fuselage locations. Do not secure the forward struts at this time.

Lay the upper wing on its top surface and carefully invert the fuselage assembly over the upper wing.

Carefully locate the outer and inner wing struts into their locations on the underside of the upper wing.

Make sure all struts are fully engaged into their locations and the upper wing is correctly aligned and horizontal.

Secure the wing struts into their locations in the underside of the upper wing, using thin CA adhesive.

Leave the assembly until the adhesives have fully set.

Carefully flex the single inner wing struts to locate them into their locations in the fuselage and underside of the upper wing. Cement the fuselage location and secure the wing location using thin CA adhesive.



Fitting the wheels:

Apply thin CA adhesive to the protruding rods installed in the undercarriage axle. Locate the 'Steve Robson' hand made wheels fully onto the rods.



Connecting the aileron control lines.

At this stage the pre-installed twin aileron control cables in the fuselage can be connected to the turnbuckles, fitted to the control cables from the upper wing.

Cut a short length of 'Albion Alloys' 0.4 mm Nickel-Silver tube (NST04).

Thread a control line from the fuselage through the cut tube then through the 'eye' end of a turnbuckle on a pre-installed control line from the upper wing.

Loop the mono-filament back through the cut tube.

Slide the tube up to but not touching the turnbuckle 'eye' end.

Keeping the turnbuckle and mono-filament inline, secure the tube in position using CA adhesive.

Cut away any excess line from the tube.

Repeat to connect the remaining three control lines.



Fitting the engine exhaust:

The 'REXx' exhaust, supplied with the Heine propeller from 'Proper Plane' can now be fitted, but although it is supplied ready to fit, I decided to tone down and weather it's somewhat glossy finish. Also the exhaust needs to have locating spigots fitted.

NOTE: *The REXx exhaust is made from very thin material, so care needs to be taken when handling the exhaust as it can be easily crushed.*

Offer up the exhaust to the exhaust ports on the right side of the installed engine and make sure all exhaust pipes touch the engine ports.

NOTE: *The exhaust pipes may be covered with a thin 'skin', which are easily drilled through.*

Using a 1.0 mm diameter drill, open up (the second from the front and rear) exhaust pipes.

Cut two short lengths of 1.0 mm diameter brass rod or similar, so that when inserted fully into the opened up exhaust pipes, they protrude by 1 mm.

Locate the rods into the pipes and secure in position using CA adhesive. Make sure the rods are not tilted at an angle in the exhaust pipes.

Refer to Part 3 of this build log and apply the 'Flory' Rust over the whole exhaust and once dry, remove as much as desired to create rust areas.

Seal the exhaust by airbrushing with 'Alclad' Light Sheen (ALC-311).

Dry brush 'Tamiya' Rubber black (XF85) in and around the exhaust outlet.

NOTE: *You may find that the exhaust tail pipe needs carefully bending down (as in the following photograph) in order to clear the fuselage frame.*

Locate the exhaust in position on the engine and secure using thin CA adhesive.



Fitting the propeller:

Locate the propeller onto the engine drive shaft and secure using thin CA adhesive.



Fitting the lift handles and pilots foot step:

Locate the pilots foot step onto the lower left fuselage frame and secure in position using CA adhesive.

Locate the two lift handles on the rear lower fuselage sides and secure in position using CA adhesive.



PART 13 - FIGURES AND ACCESSORIES

The two figures I chose to use for this model were the 'Blackdog Models' German Photographer with camera (F32008) and the 'Aviatic' Legend Series - Anthony Fokker (ATTL-02). The construction and painting of these figures are covered in the associated Fokker D.VII model build.

PART 14 - DISPLAY

The display case is made from 6mm thick Piano Black Acrylic sheet and the transparent top is fabricated from 3mm thick Clear Acrylic sheet, which was by an on-line manufacturer:

Web Site - Ebay retailer - 'Inperspective'

The name plaque was also made by an on-line retailer:

Web Site - <https://theengravingshop.co.uk>

A standard 12 inch mirror tile was fixed to the acrylic display base, using self adhesive pads with the information plaque mounted on the mirrored tile.

The model itself has rubber tyres and metal wheels, so could not be fixed to the display base by using my normal method of inserting metal pins into the wheels then into the display base. Therefore this model is displayed on horizontal shelving and the model sat, unsecured, on its display base. I decided not to have any figures or groundwork, but instead to stand the model on a mirrored base. Doing this allows the viewer to see the underside detail as well as the rest of the model. It also means the viewer is not distracted from the model by surrounding detail.



COMPLETED MODEL PHOTOGRAPHS



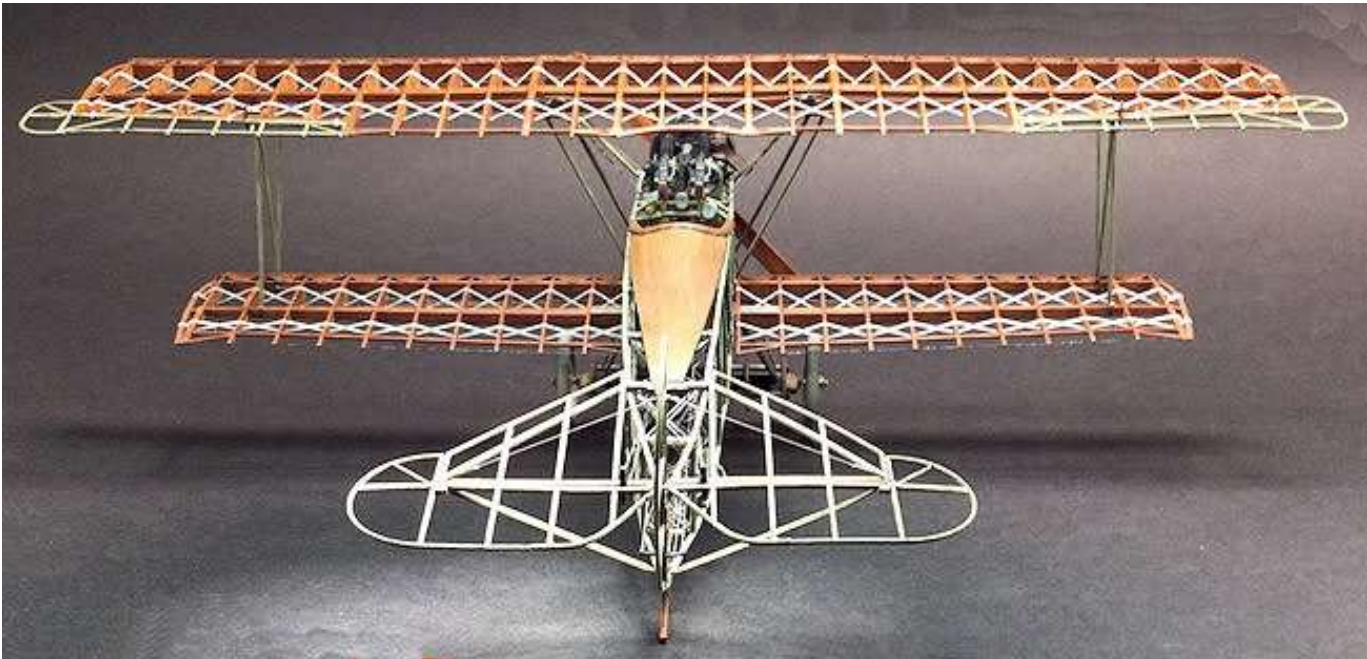
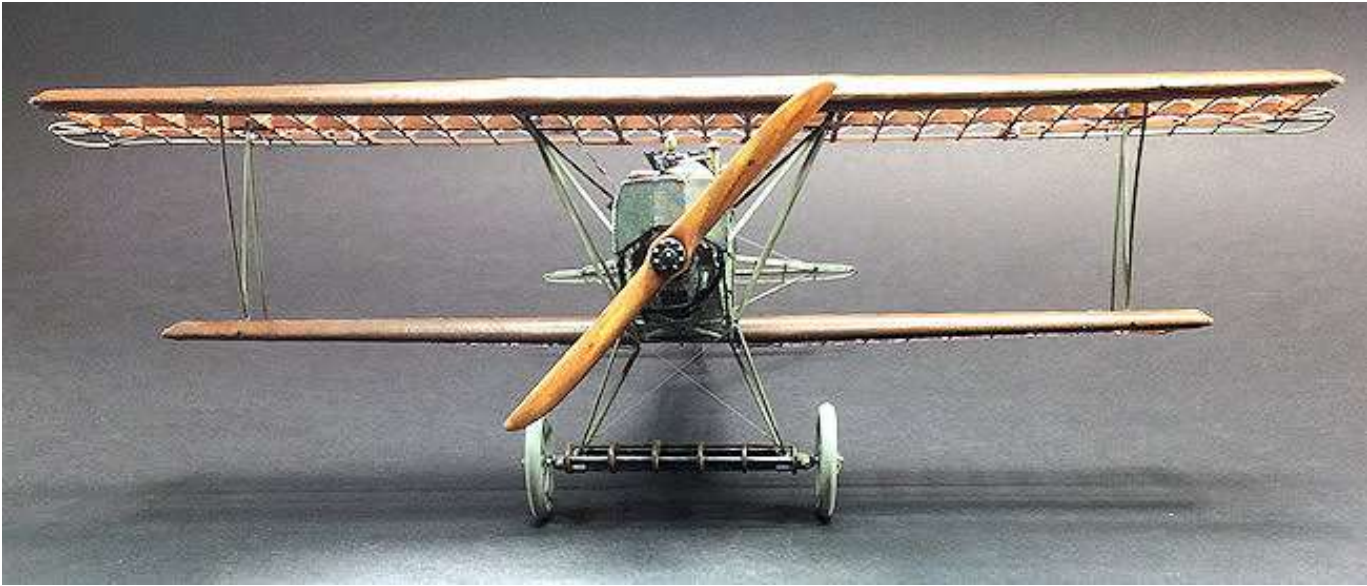

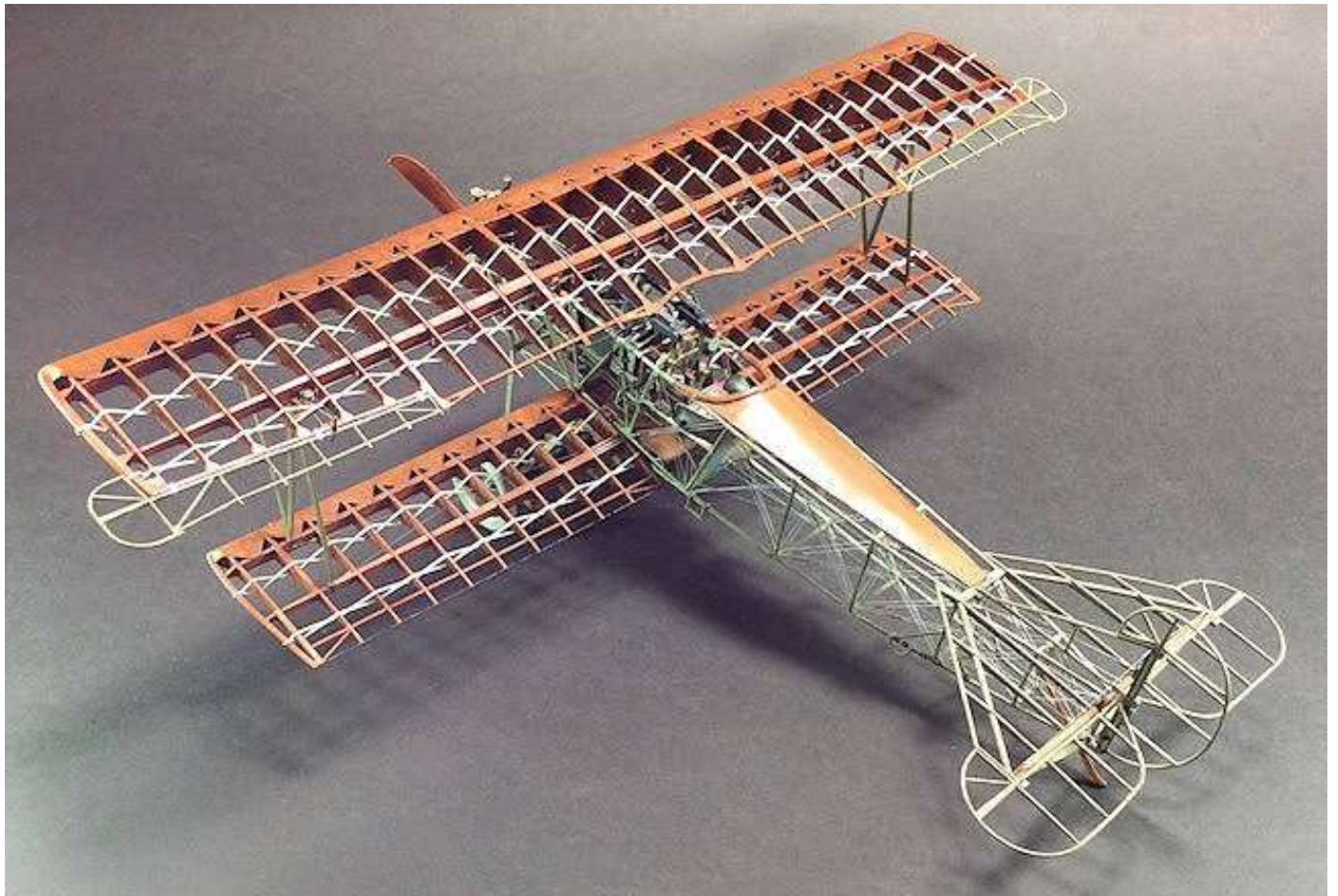
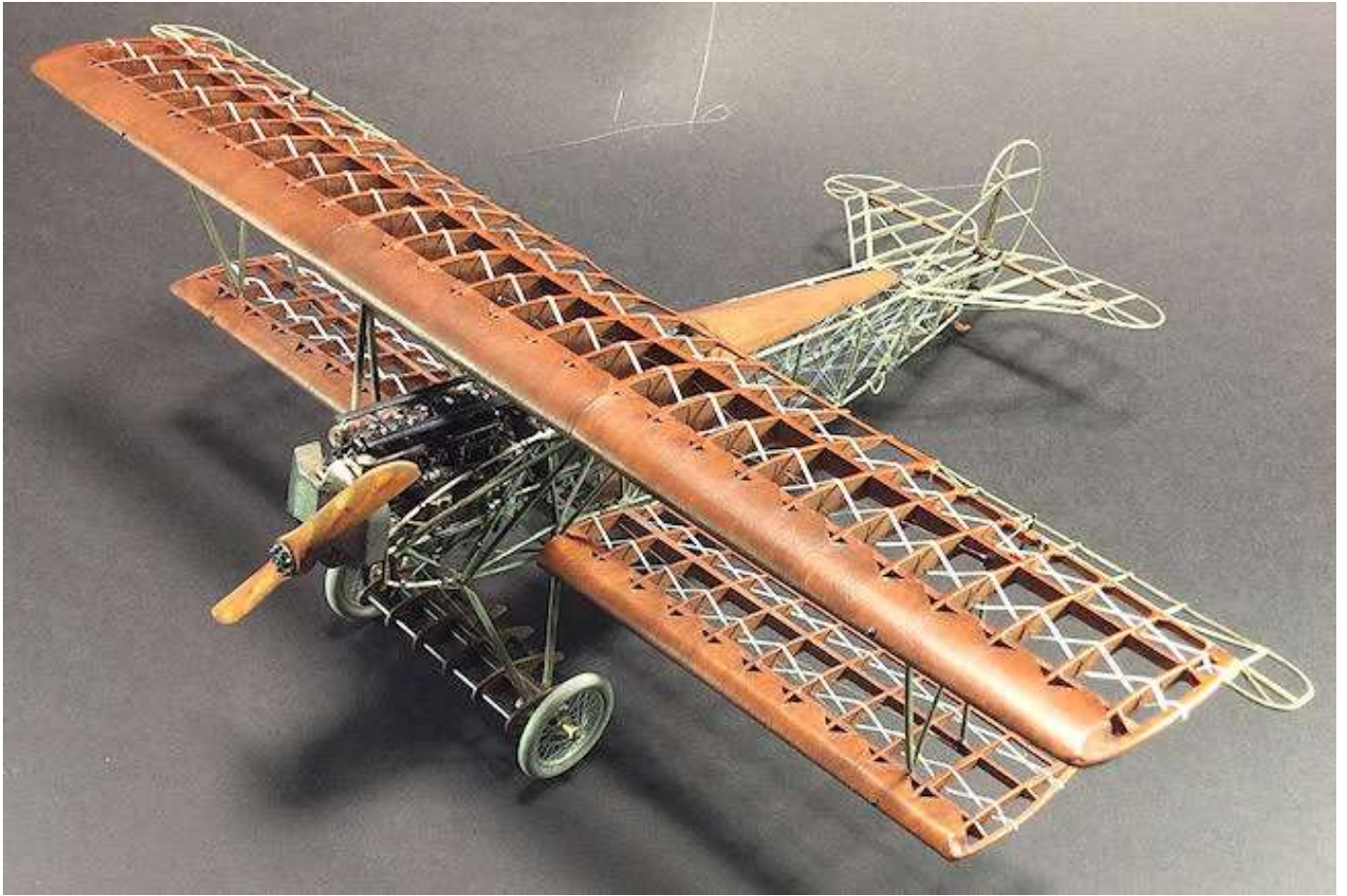

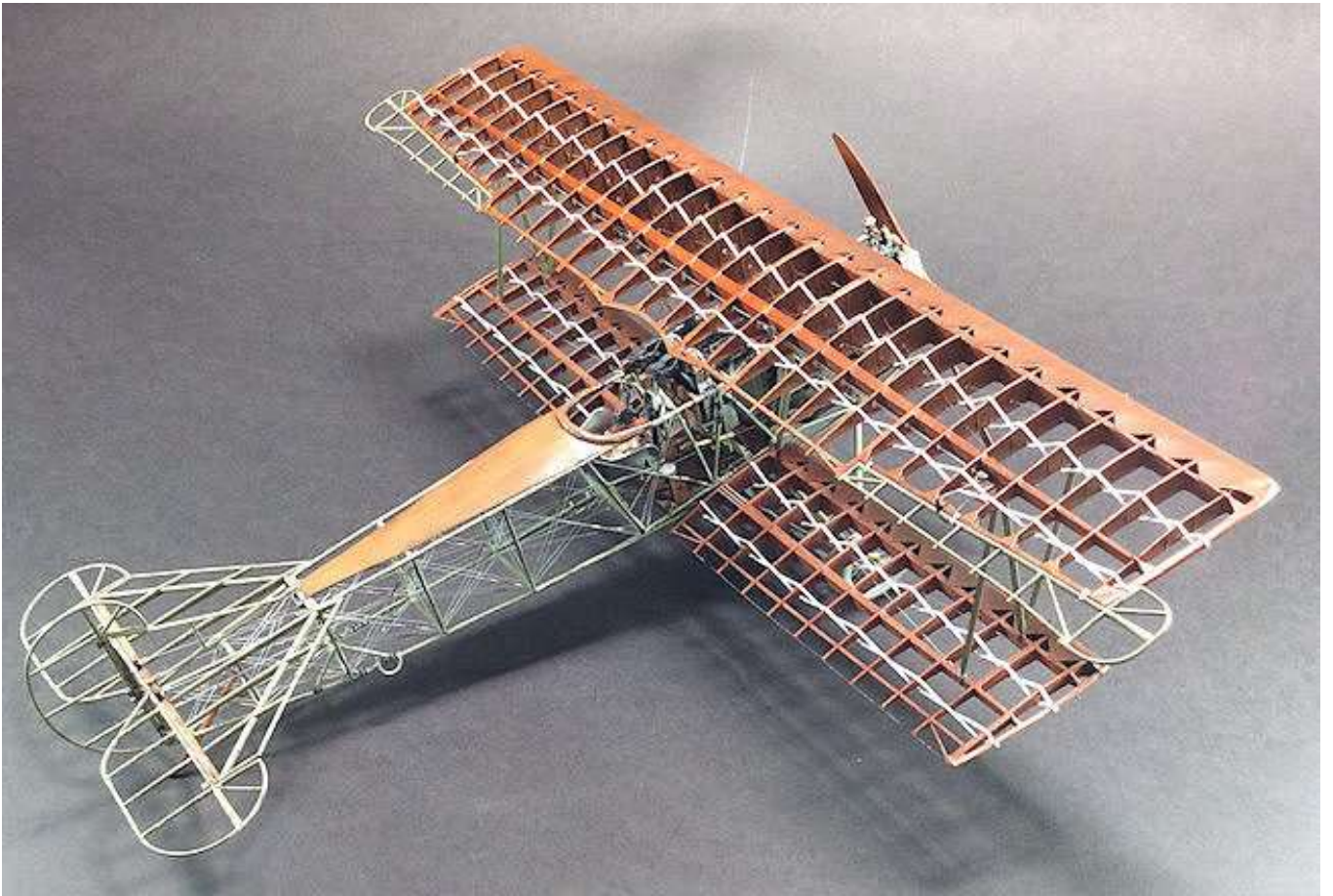

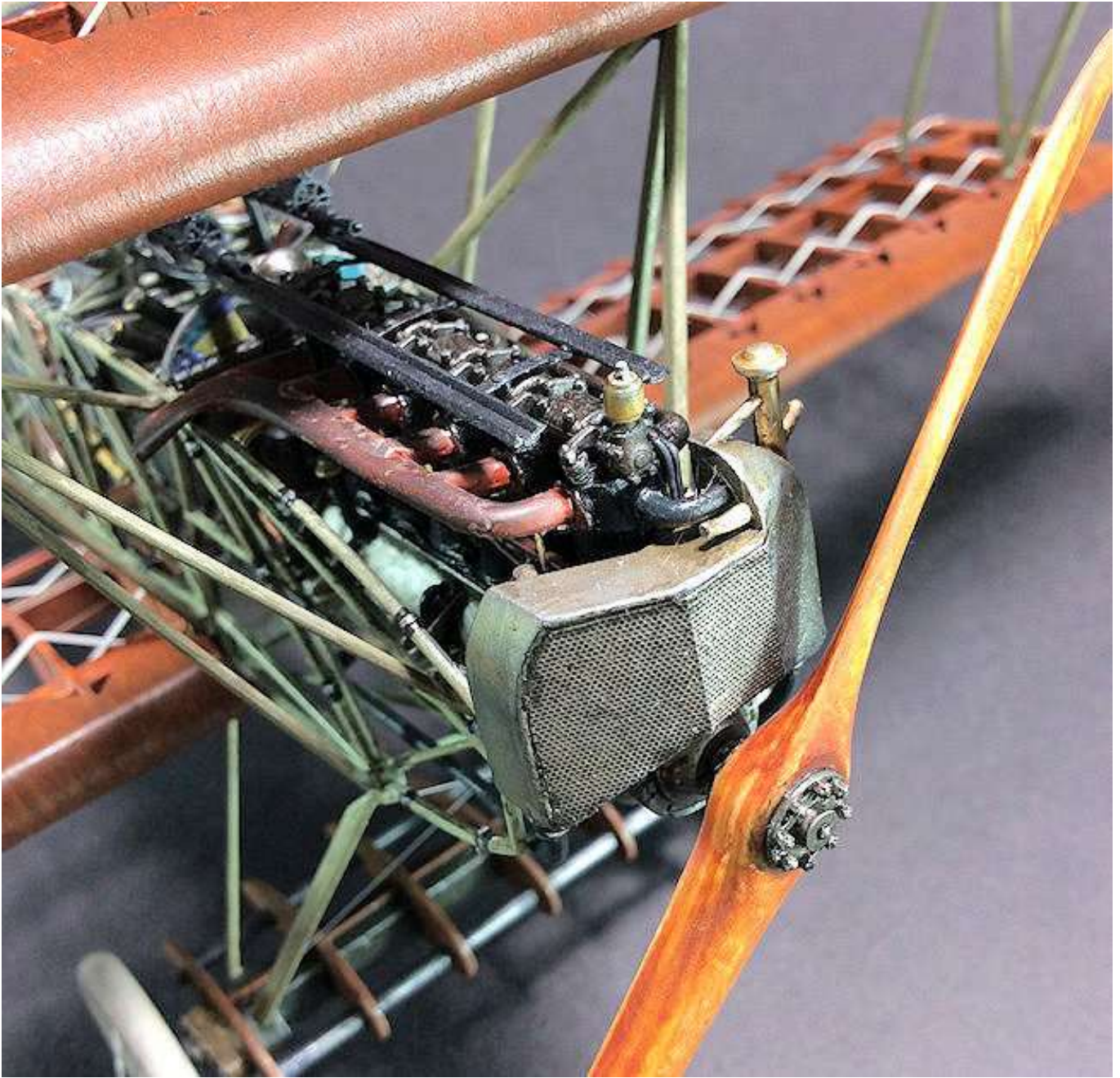

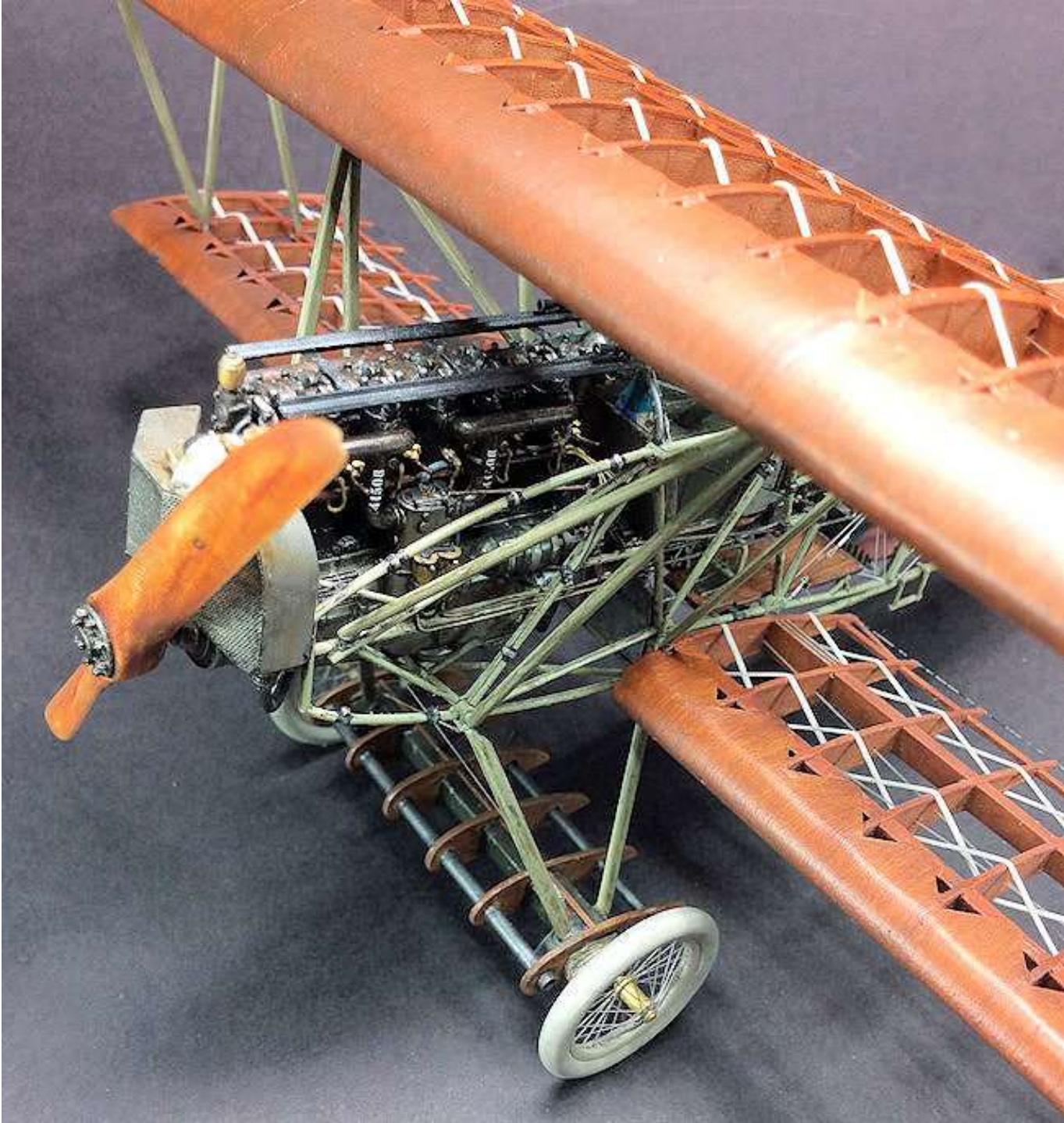

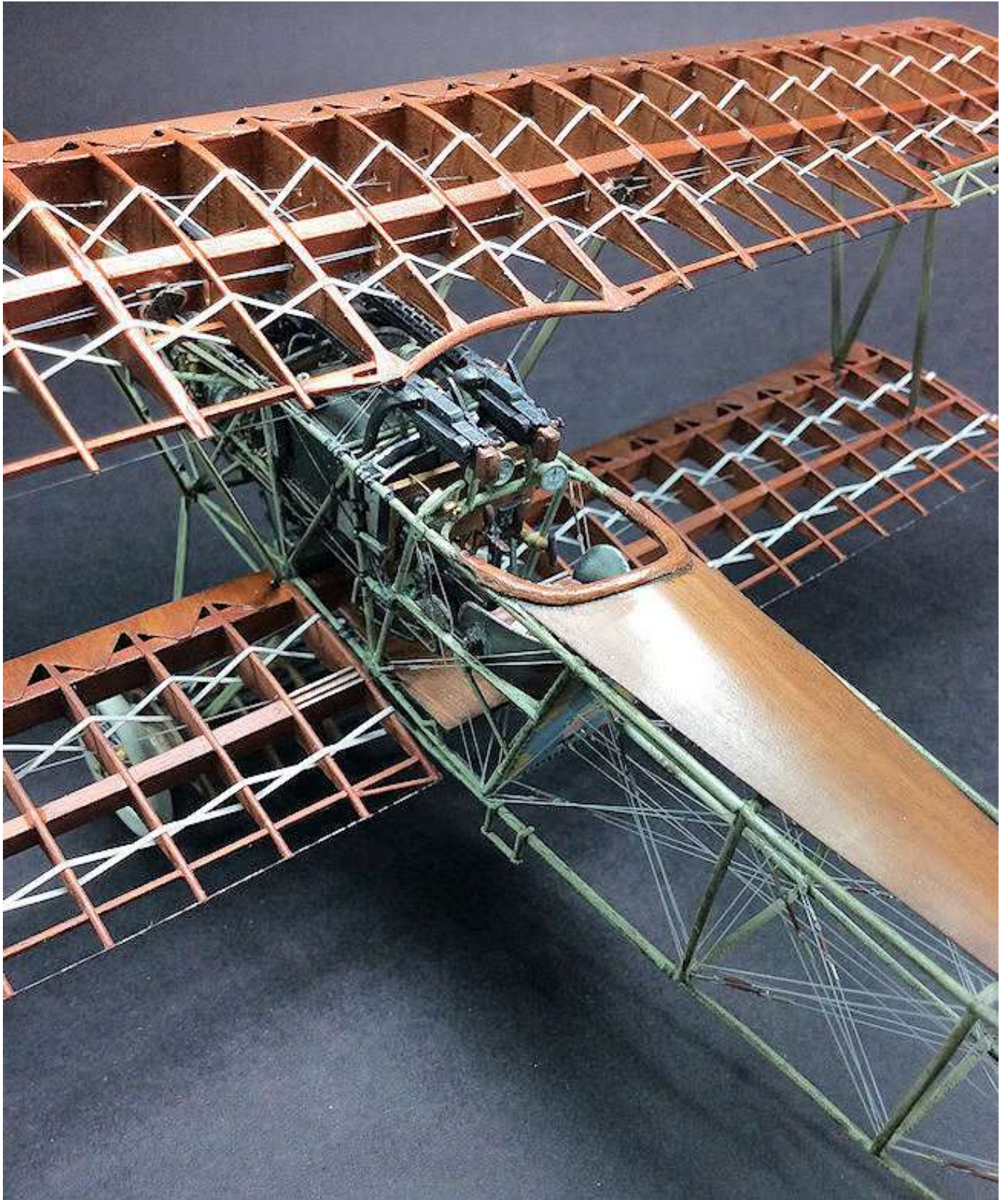

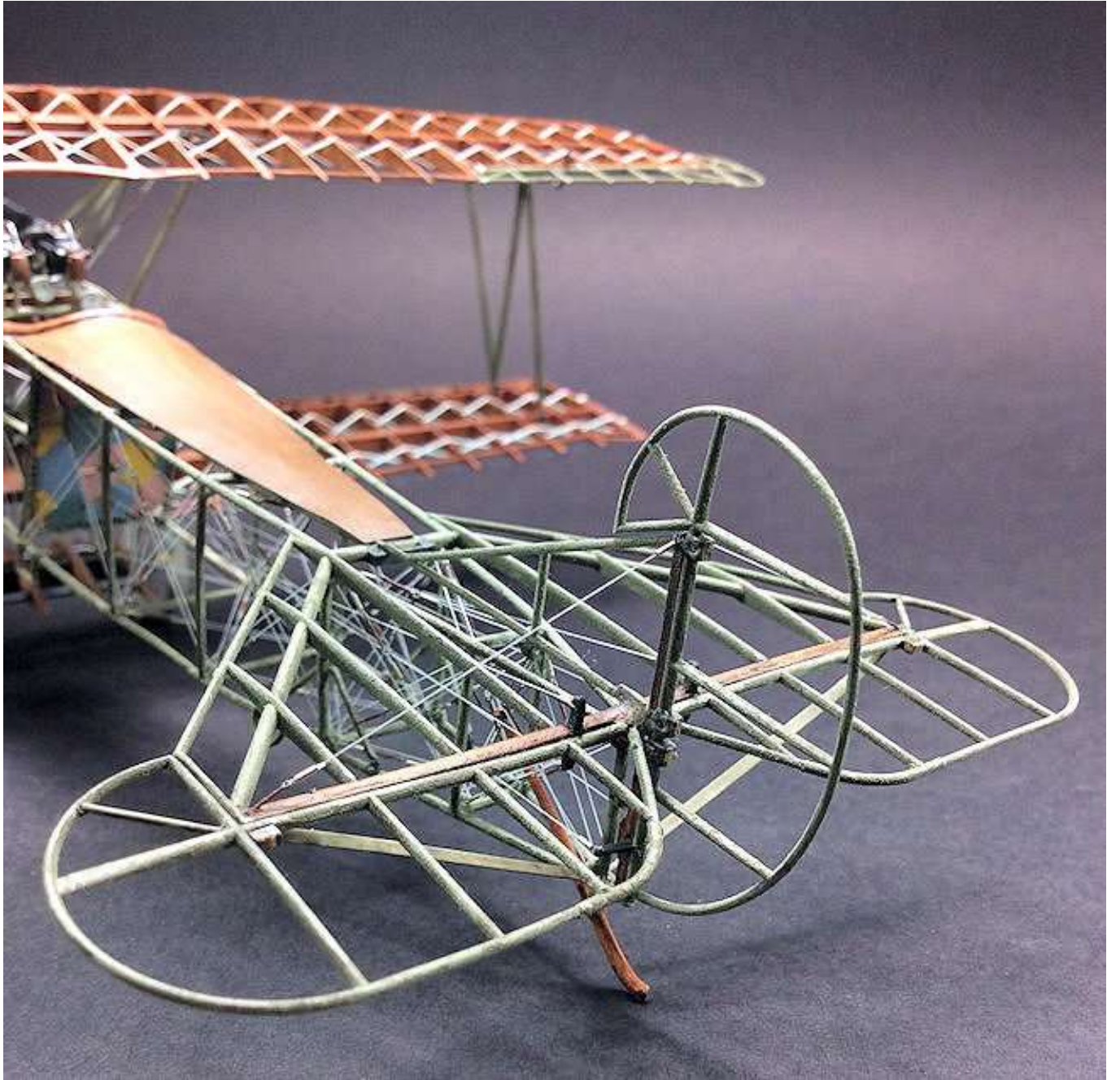

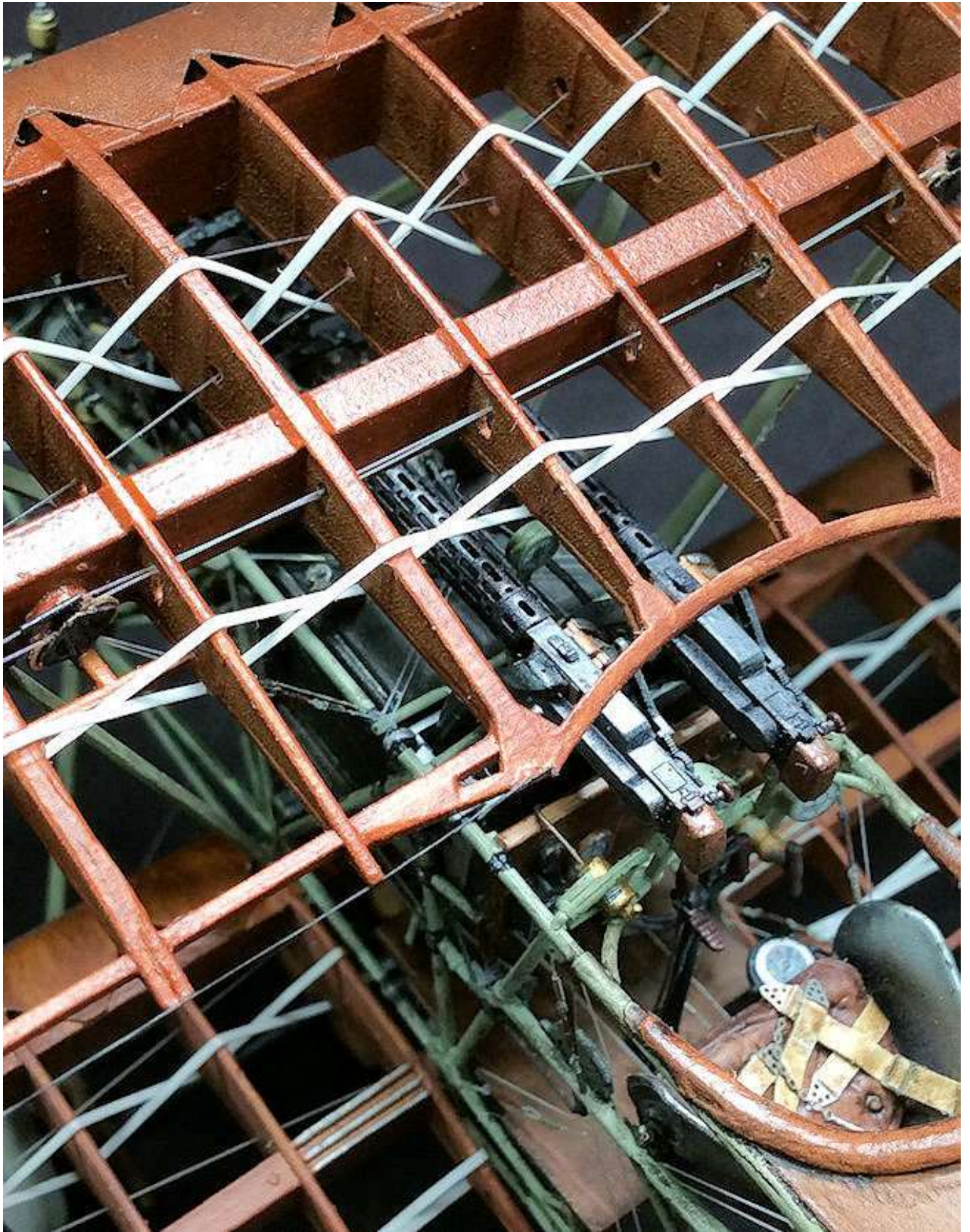

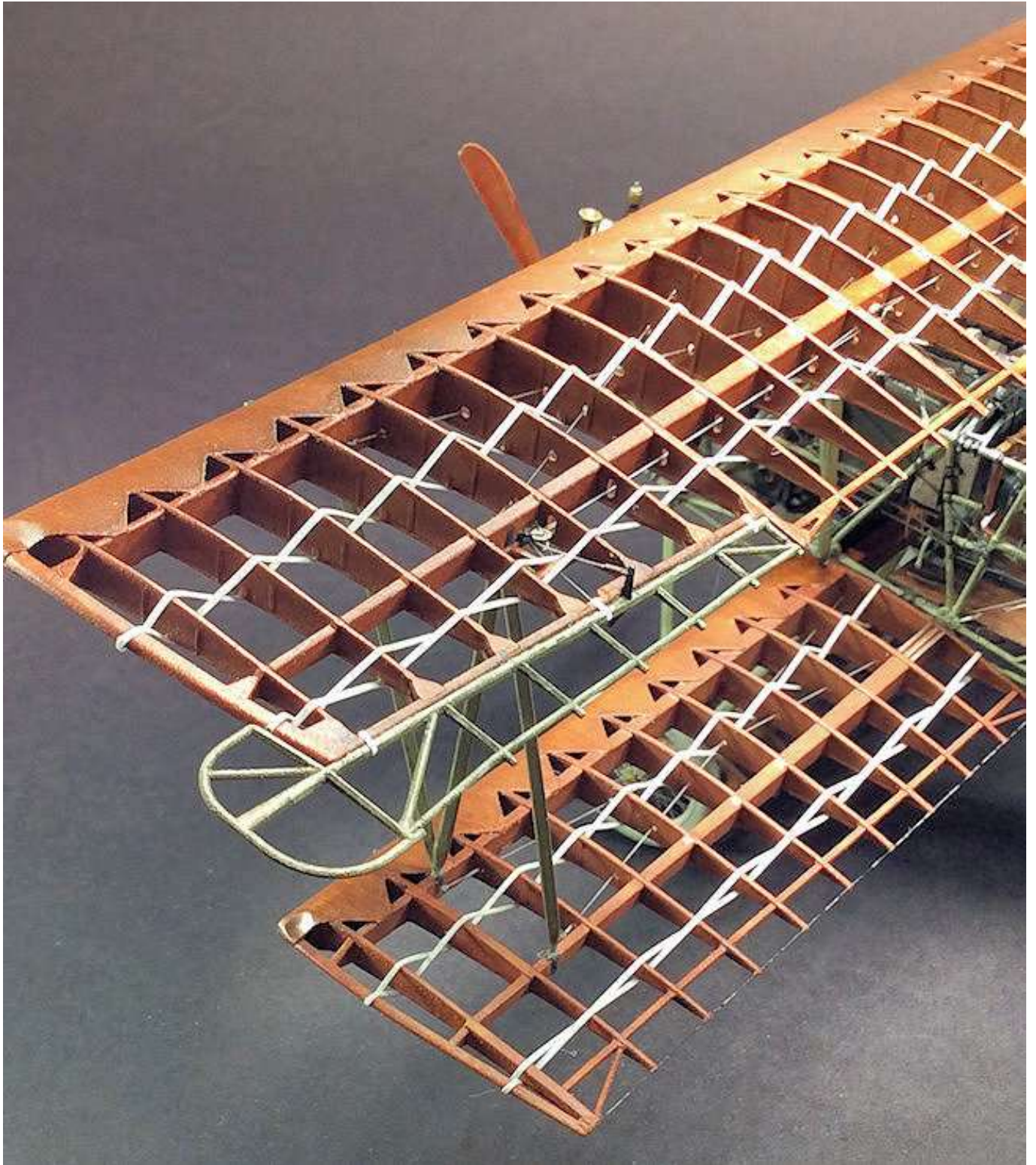

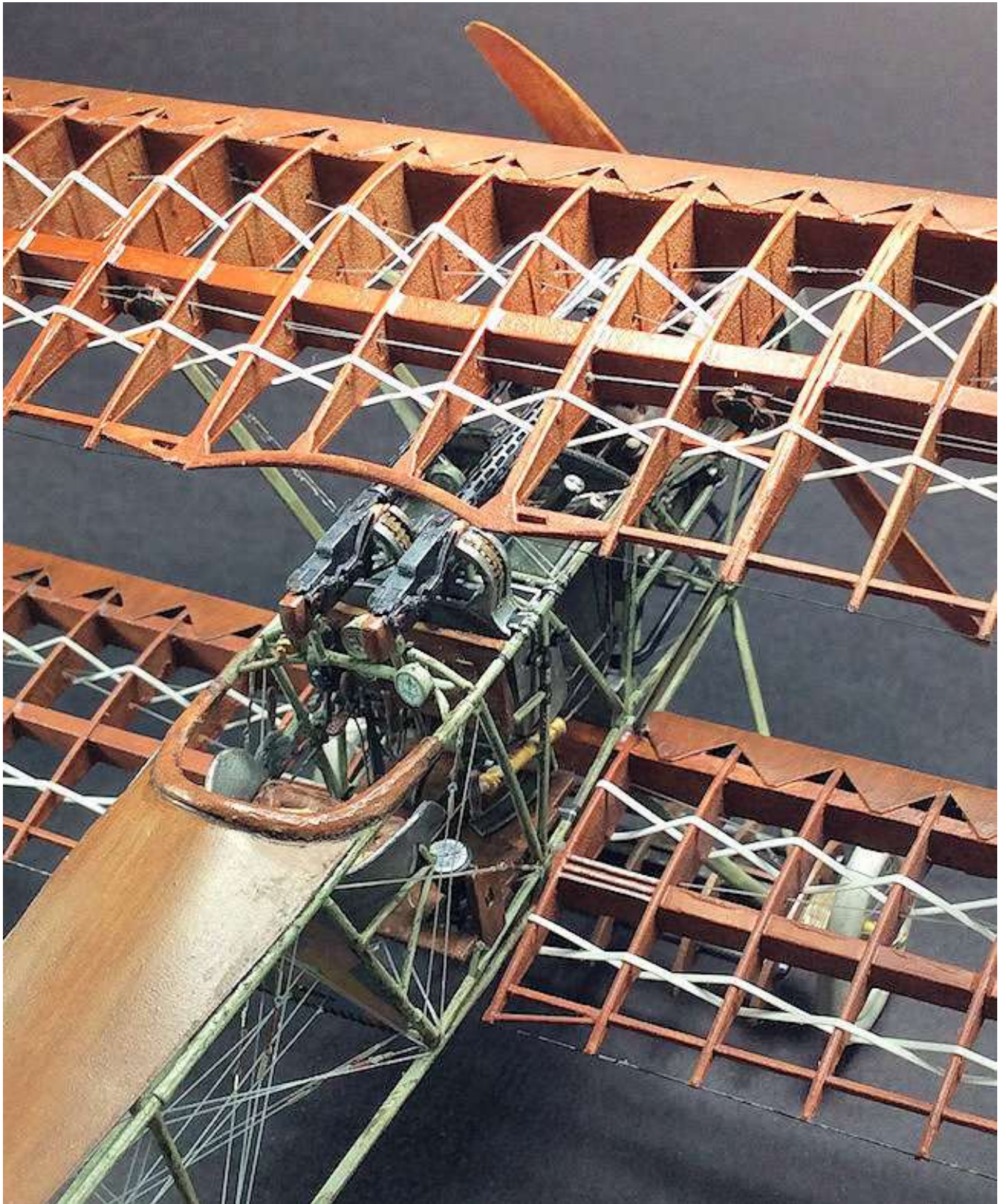

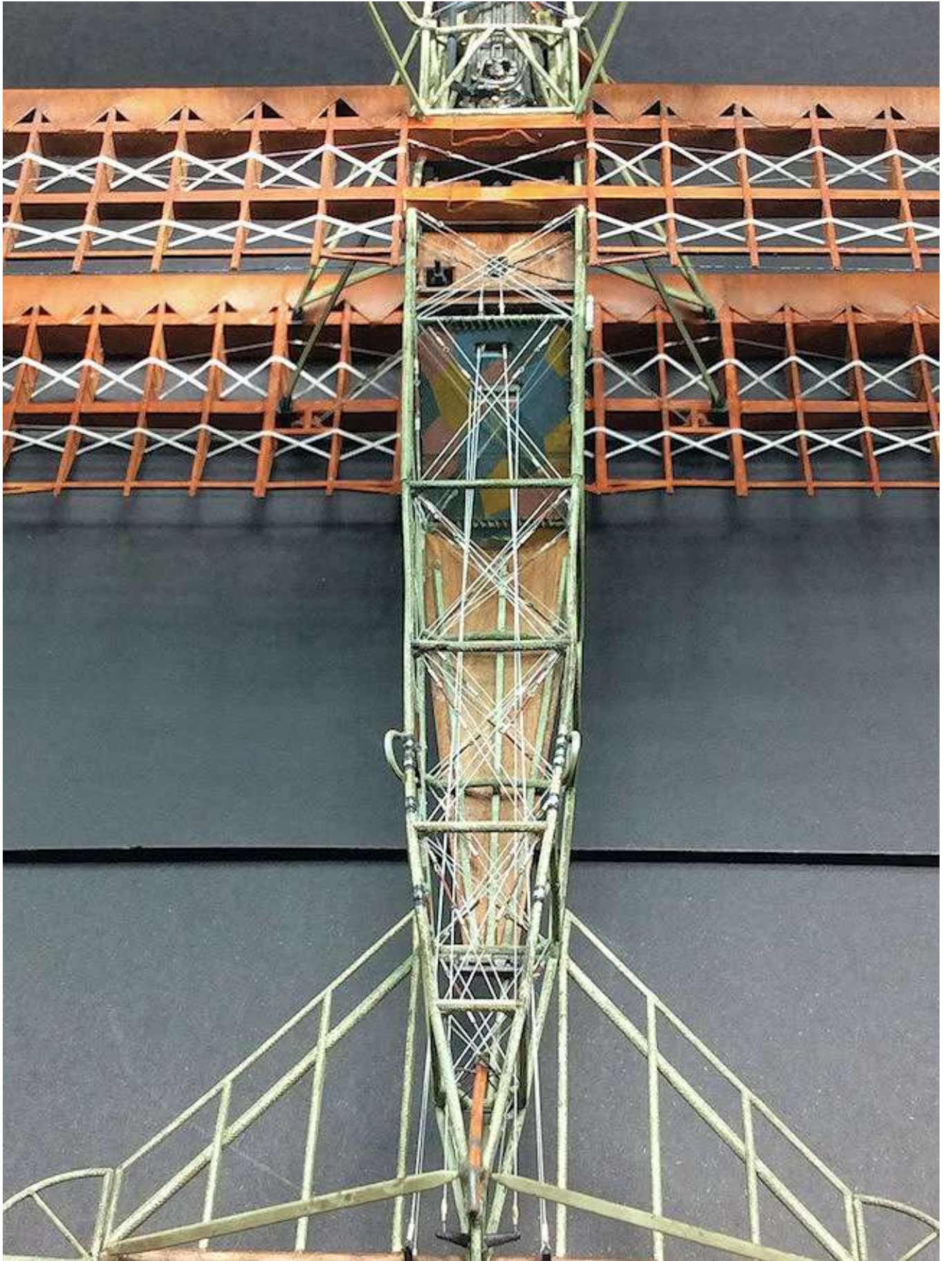

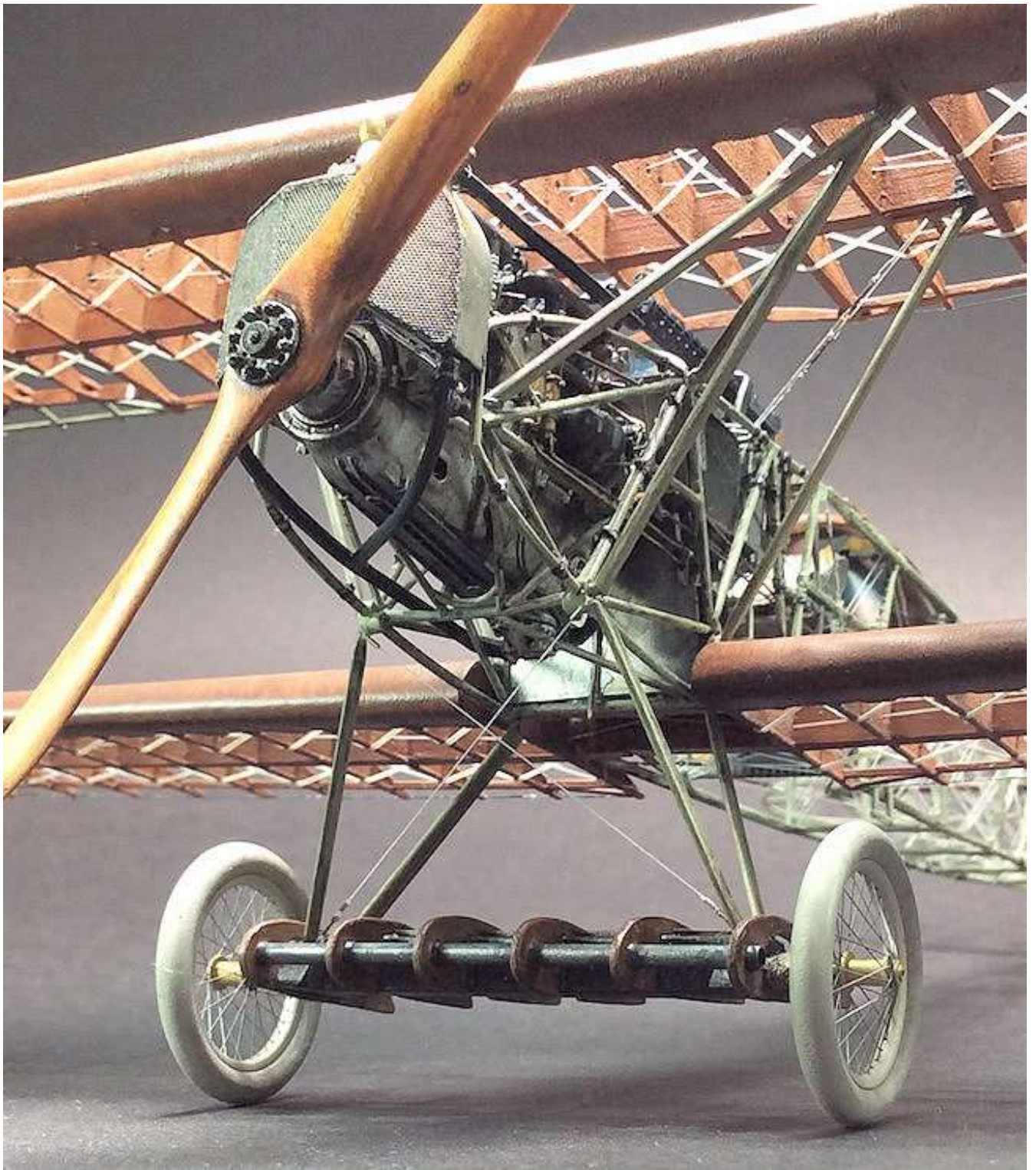

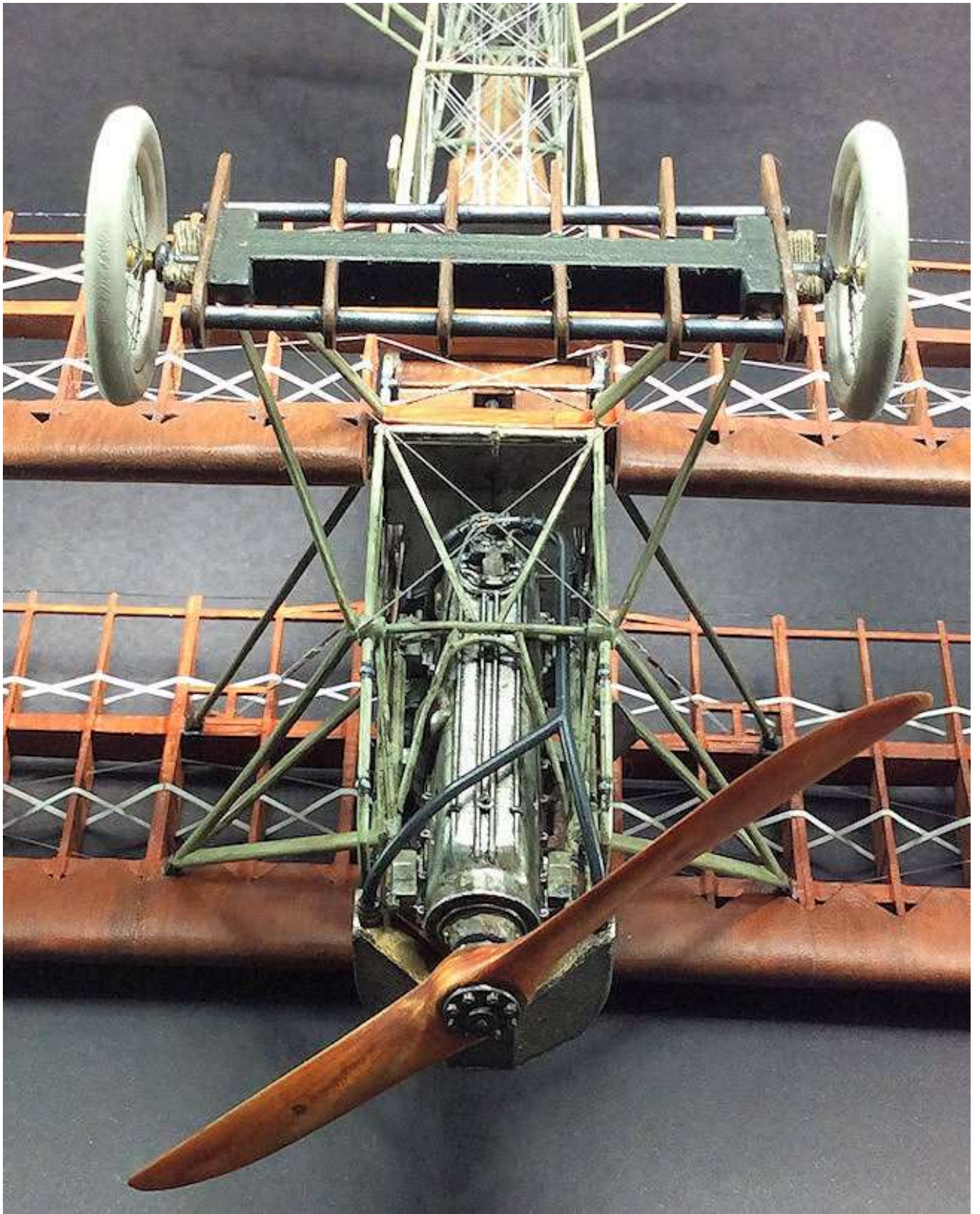

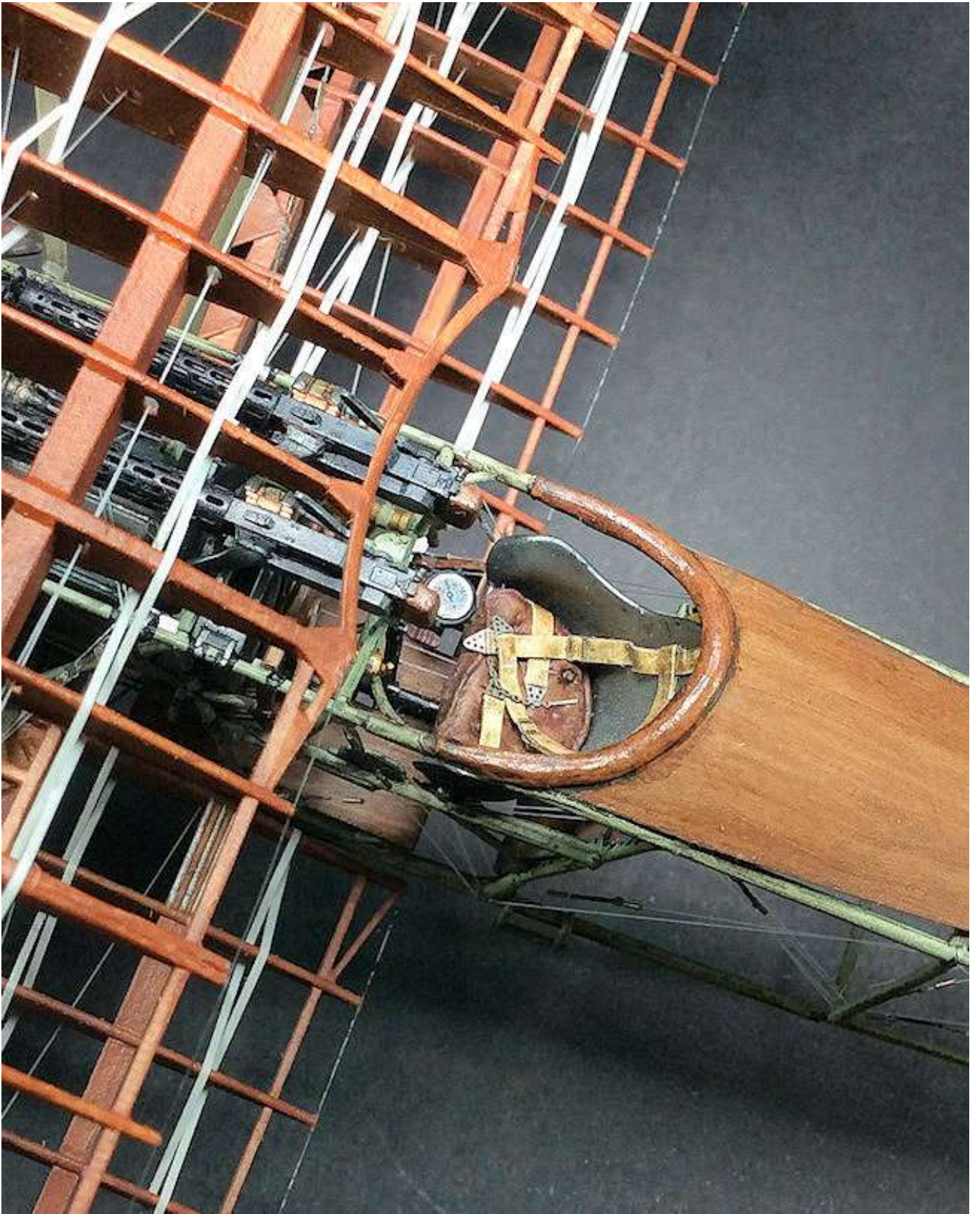

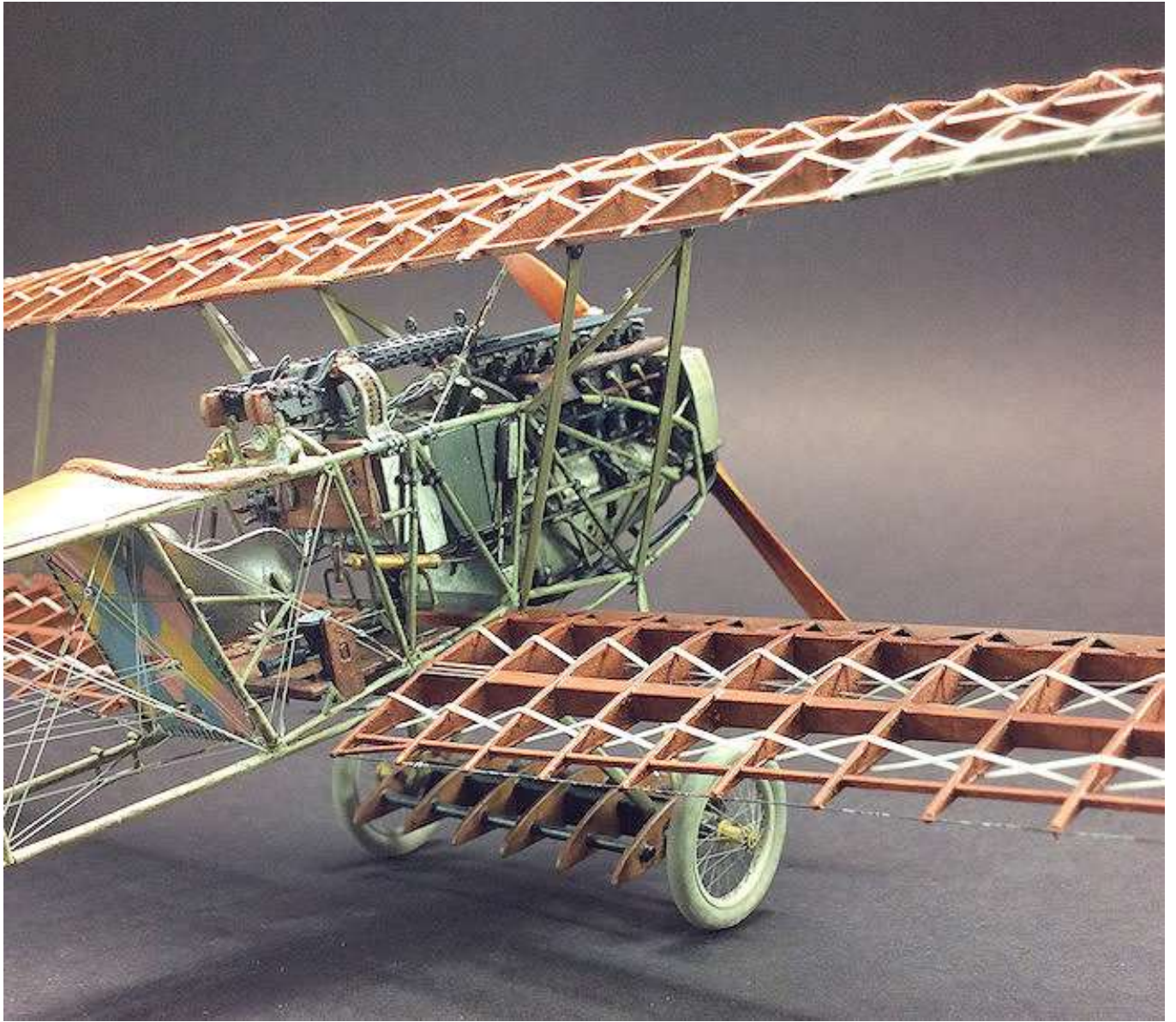

END