



World War One Aircraft Models

I have always held a fascination with early military aircraft. After serving for 27 years in the Royal Air Force, I became a Military Aerospace Technical Author. Although, as most modelers, I got involved in the world of construction kits at an early age, I stopped for most of my service career and for some years afterwards.

I started modeling again a few years ago and now enjoy the challenge of building aircraft of World War One. Since posting photographs of my completed models online, several people have asked if I would create a 'build log' for future builds.

I don't consider myself a 'master' of this craft, but hope to be able to pass on what I have learned. As such, here is my build log, which covers the 1:32 scale model of the Fokker D.II by 'Special Hobby'.

Mike 'Sandbagger' Norris

sandbaggeruk@sky.com

Completed: April 2021

CONTENTS

INTRODUCTION

AFTER MARKET

THE AIRCRAFT

PART 1 - MODEL DESCRIPTION

PART 2 - WOOD EFFECTS (General)

PART 3 - WEATHERING (General)

PART 4 - DECALS (General)

PART 5 - RESIN (General)

PART 6 - RIGGING

PART 7 - ENGINE

PART 8 - WEAPON

PART 9 - PROPELLER

PART 10 - FUSELAGE AND WINGS

PART 11 - CONSTRUCTION

PART 12 - FIGURES

PART 13 - DISPLAY BASE

PART 14 - COMPLETED MODEL PHOTOS

INTRODUCTION

Before I start with the build log, I'd like to show how I've set up my work area. I prefer to keep the work area as clear as I can (I've lost too many small items in the past). I think it's important to have the tools etc you need ready to hand and other, non-essential stuff tucked out of the way until needed. I'm lucky in that I have my 'man cave', which is sorted into a modelling area, airbrush spray booth in addition to my work station PC, games PC and games console.

Sorted



AFTER MARKET

AFTER MARKET

Figure

'Kellerkind Miniature' Germane engine crew (54101),
'Wings Cockpit' figures - seated LSK pilot (LSK 04A).

Decals

'Aviatic' WW1 Fokker 'streaked' camouflage (ATT32058),
'Aviatic' Linen Weave effect (ATT32236)
'Airscale' WW1 instrument decals (AS32 WW1),
'Xtradecal' Parallel Stripes (Black XPS1)
'Xtradecal' Parallel Stripes (White XPS2).

Propeller

'ProperPlane' Lang propeller.

Weapons

'GasPatch' early LMG 'Spandau' 08.

Rigging accessories (as required)

'GasPatch Elite Accessories' Turnbuckles 1/48 scale,
'Albion Alloy's' Micro-tube (Brass or Nickel Silver - various diameters).
'Steelon' mono-filament 0.12 mm diameter',
'Stroff' mono-filament 0.08, 0.12 mm diameter,
'Maxima' Chameleon mono-filament 0.12 mm diameter.

Sundries (as required)

'Araldite' two part epoxy adhesive, Paints ('Tamiya' Acrylic, Humbrol Acrylic,
'Mr. Metal Colour', 'AK Interactive' Primer and micro-filler (Grey AK758, White AK759),
'AK Interactive' Filters (Wood AK-261) and figure paints, Kerosene AK-2039, Oil AK-2019
and Wash AK-2033), 'Alclad II' Lacquers, 'Alclad' Aqua Gloss 600, 'Mr. Colour' Levelling
Thinners, 'Vallejo' Model Colour, PVA Adhesive (e.g. 'MicroScale' Kristal Klear),
'VMS Fleky' CA adhesive (Standard and Thin) and Metal Prep 4K, 'Bostik' Blue,
UHU White Tack, 'AV' Masilla Plastica (401) putty, 'De-Lux Materials' Perfect Plastic Putty,
Sanding and/or Polishing sticks from 'Flory Models', 'Humbrol' Maskol, 'UHU' White Tack,
'Milliput' two part putty, 'White Spirits', 'MicroScale' MicroSol/MicroSet,
'Mr. Surfacer 500, 1000,1200', 'DecoArt Crafters Acrylic' (water based) paints,
'Artool' Ultra Mask sheets, 'Vallejo' Still Water (26.230), 'Milliput' two part clay,
'Mr. Surfacer' primer and filler, 'Hataka' lacquer paints, 'Plastruct' styrene rod,
'PlusModel' lead wire, 'ANYZ' black braided line (AN001), 'Tamiya' extra thin liquid cement,
'Plastic Magic' liquid cement, 'Prismacolor' Verithin Argent Metallique 753,
'Bare-Metal' Matte Aluminium foil, 'MFH' black 0.4 mm flexible tube (P-961),
'EZ' stretch line (heavy white).

Weathering mediums (as required)

'Flory' Clay washes, Flory Pigments, AK Interactive engine washes,
'Tamiya' Weathering Master (Set C, D and E), 'Derwent' Inktense 24 ink pencils.

Display Base

Etched Plaque (name plate),
'Inperspective' custom made Acrylic base and cover,
'Polak' Wild Meadow (Variation C - 4703).

THE AIRCRAFT

THE AIRCRAFT

References:

1. 'Special Hobby' kit instructions.
2. Various online sources.
3. 'Fokker Fighters D.I - D.IV' (P.M. Grosz).

This model represents a Fokker D.II, serial number not known, attached to 'Kampfeinsitzer Staffeln' (Kest) 4b sometime between April 1917 - October 1918 at Royal Bavarian AF, Freiburg.

During 1915 the Fokker E type monoplanes were the dominant fighters operating over the Western Front, but eventually were superseded by better allied fighters, such as the French Nieuport and British Airco DH.2 fighters. In an attempt to counter these allied aircraft, Martin Kreutzer, an aircraft designer working at the Fokker company, designed several types of biplane fighter. The Fokker Type M17 was a single-bay biplane with a high fuselage almost filling the gap between the wings. Later, to ensure a better forward visibility for the pilot, the fuselage height was reduced and a slight stagger was introduced to the wings. In addition, different types of two-bay wings were tested as well as different power units. Finally, two versions reached production status, the Fokker B.II, which was a single-bay type with a 80HP Oberursel U.0 engine and the Fokker D.II, which featured a two-bay wing structure and a 100HP Oberursel U.I engine.

The construction of the D.II was based on that of the Fokker E type monoplanes and used wing warping technology as this was before the use of ailerons became standard. The aircraft was armed with a single early LMG 'Spandau 08 machine gun.

Whilst the B.II type was only used for training purposes by the German military, the D.II was chosen as an operational fighter. The D. II was armed with a single synchronized machine gun and the first production batch of 181 aircraft reached the front in the summer of 1916 and were in operational use until August 1917. However, by late 1916 they were employed less over the more exposed sections of the front and were relegated more to defend industrial centres against bomber raids of the Allies. The German Navy also used six of the type and Austro Hungary also bought a licence to build both the B.II and the D.II, putting them into production under the designation of Fokker series 03.5 and 03.6.

The aircraft being modelled, photographed at Freiburg



As usual it's difficult to ascertain the colours of the actual aircraft from photographs taken at that time. The artist Bob Pearson has created probably the nearest colour profile for the aircraft. This profile shows only the side view of the aircraft, so there could be some conjecture as to the colouring of the upper and undersides of the aircraft. However, the 'Special Hobby' colour guides along with aerial photographs of similar aircraft help to best guess what these colours were. Earlier production aircraft had their upper and lower wing top surfaces and tail plane spray painted with alternate red-brown and olive green patches with their undersides of either clear doped linen (CDL) or light blue. The fuselage for this aircraft had olive green painted forward fuselage, engine cowl and rear decking panel. It appears possible that the sides of the mid-fuselage area was the Fokker streaked linen camouflaged, as was the upper surface of the fuselage. The rear sides of the fuselage were white. The underside of the fuselage and tail plane were CDL or light blue. The rudder was painted black with the national cross in white. As was normal on rotary engine powered aircraft, the chemical effect of castor oil and fuel from the engine caused deterioration of any applied paint and dope to the rear of the engine. These particular aircraft seemed more prone to this than most.

Composite profile of this model.

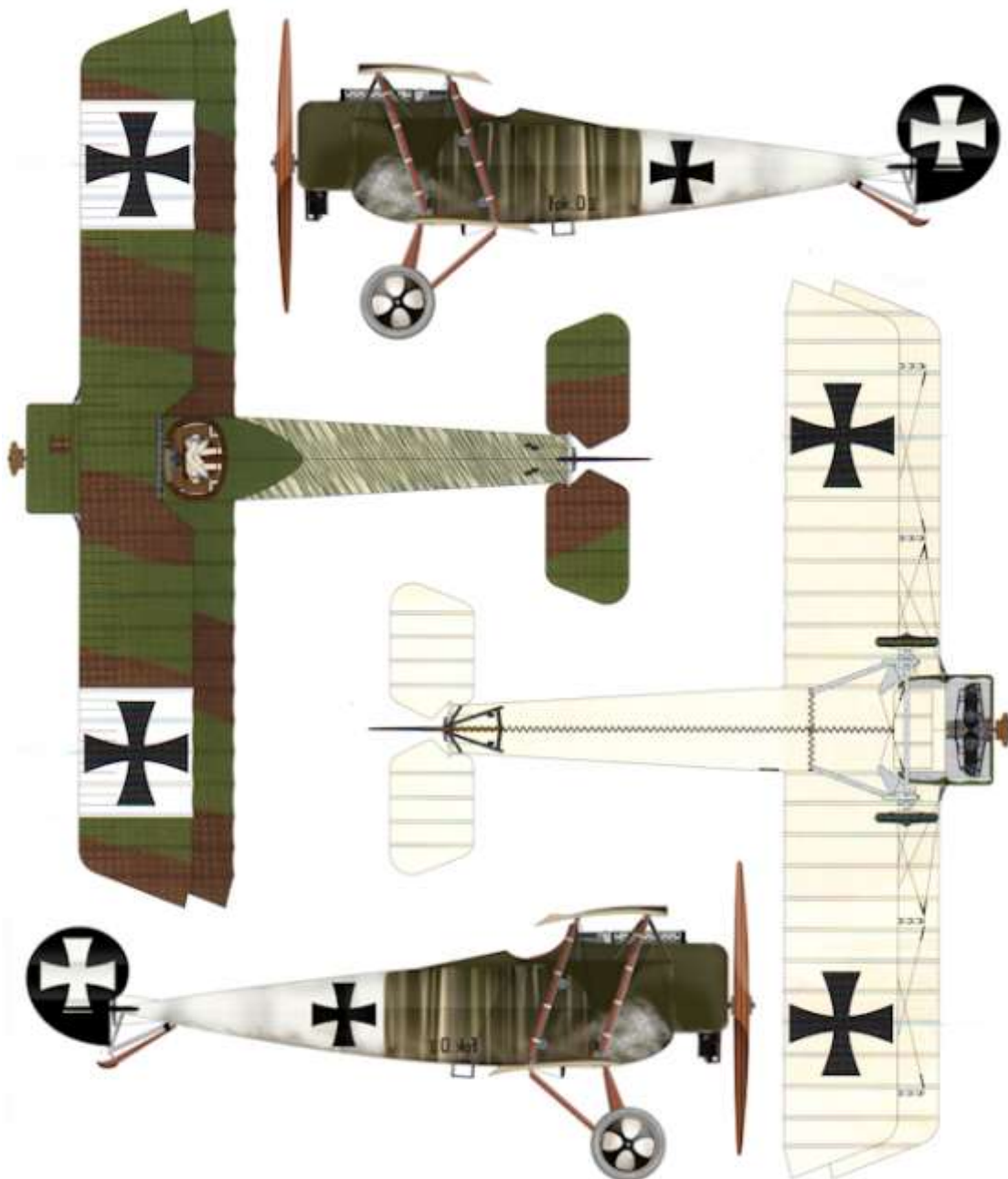

PART 1
MODEL
DESCRIPTION

PART 1 - MODEL DESCRIPTION

(‘Special Hobby’ - Kit No:SH32064)

Normally here I would write a basic description of the model, noting any points of interest or flaws.

However, there is already an excellent review of the kit by Jeroen Peters at the ‘Large Scale Modeller’ forum.

Paste the link below into your internet browser to view his review.

[Special Hobby 1/32 Fokker D.II “Black & White Tail” - Aircraft Reviews - Large Scale Modeller](#)

Observations:

The following are observations made by Jeroen in his review of this kit and my initial observations of the kit before building it.

1. I found that the supplied decal sheet is good, but there is a lot of unnecessary transparent carrier film around most of the decals. As these areas of carrier film have no colour, any air trapped under them can cause ‘silvering’, which will be obvious once the decal has dried and set. These areas of carrier film should be carefully cut away as close as you can to the decal or as I chose, to create masks where possible.
2. The rigging for this model is intended to be fitted to the model using the supplied photo-etch fittings. However, it is difficult to secure these to the model such that they don’t pull off when the rigging lines are fitted and tightened. Also, being photo-etch, they are flat (two-dimensional) and are not very convincing. Therefore I chose to replace these with ‘GasPatch’ 1:48th scale metal turnbuckles and copper wire anchor points, which are more realistic and stronger when fitted.
3. Jeroen suggests that the pilots seat cushion is basic and should be modified to make it look more realistic.
4. Jeroen suggests that the pilots seat harness, being photo-etch, could be replaced with an applicable harness from ‘HGW Models’, which are canvass effect paper with photo-etch fittings.
5. Although the propellers supplied in the kit are usable, I chose to use instead a hand made laminated wood propeller from ‘ProperPlane’, as these propellers faithfully reproduce the lamination layers of a real propeller.
6. I chose to replace the kit supplied machine gun with the early LMG 08 ‘Spandau’ machine gun from ‘GasPatch’. These weapons are resin cast with very fine detail.
7. Jeroen suggests sanding down the linen wrapping strips around the wing struts as they appear to be too pronounced.

PART 2
WOOD EFFECTS
(General)

PART 2 - WOOD EFFECTS (General)

A basic technique:

Parts of the model that are supposed to be made of wood can prove to be a challenge to replicate a wood finish to the part. Some after market companies produce accurate wood decals, which can be used to cover larger areas, such as cockpit decking and fuselage panels. However, decals can't easily be used to create realistic wood finish to smaller items or parts that don't lend themselves to having decals applied. To do this requires brush painting, using such as acrylic or oil paints, which can be enhanced with various washes or filters.

The first thing to do is to ensure the model parts are cleaned, normally with warm water with washing up fluid and something like an old tooth brush. Once cleaned and thoroughly dried, the primer coat can be applied. I use 'Tamiya' Aerosol Light Grey (Fine) or White (Fine) acrylic primer. Once the primer is dry, you can start applying the wood effect to the applicable cockpit items, such the cockpit framework, decking, seat supports, rudder bar, instrument panel and of course, the wing struts. With practice, this method can also be used on fuselage panels and propellers.

To start, apply a suitable base colour. For most painting I use an airbrush and only resort to brush painting when dealing with small items, when I add a few drops of 'Mr. Colour' Levelling Thinner', which aids brush painting. For most wood effect, I use 'Tamiya' Wooden Deck Tan (XF78) or Dark Yellow (XF60), suitably thinned with 'Tamiya' Thinners (X20A). Allow this base coat to fully dry (if you can't smell the paint, then it's dry).

Example of base coat using 'Tamiya' Wooden Deck Tan (XF78).

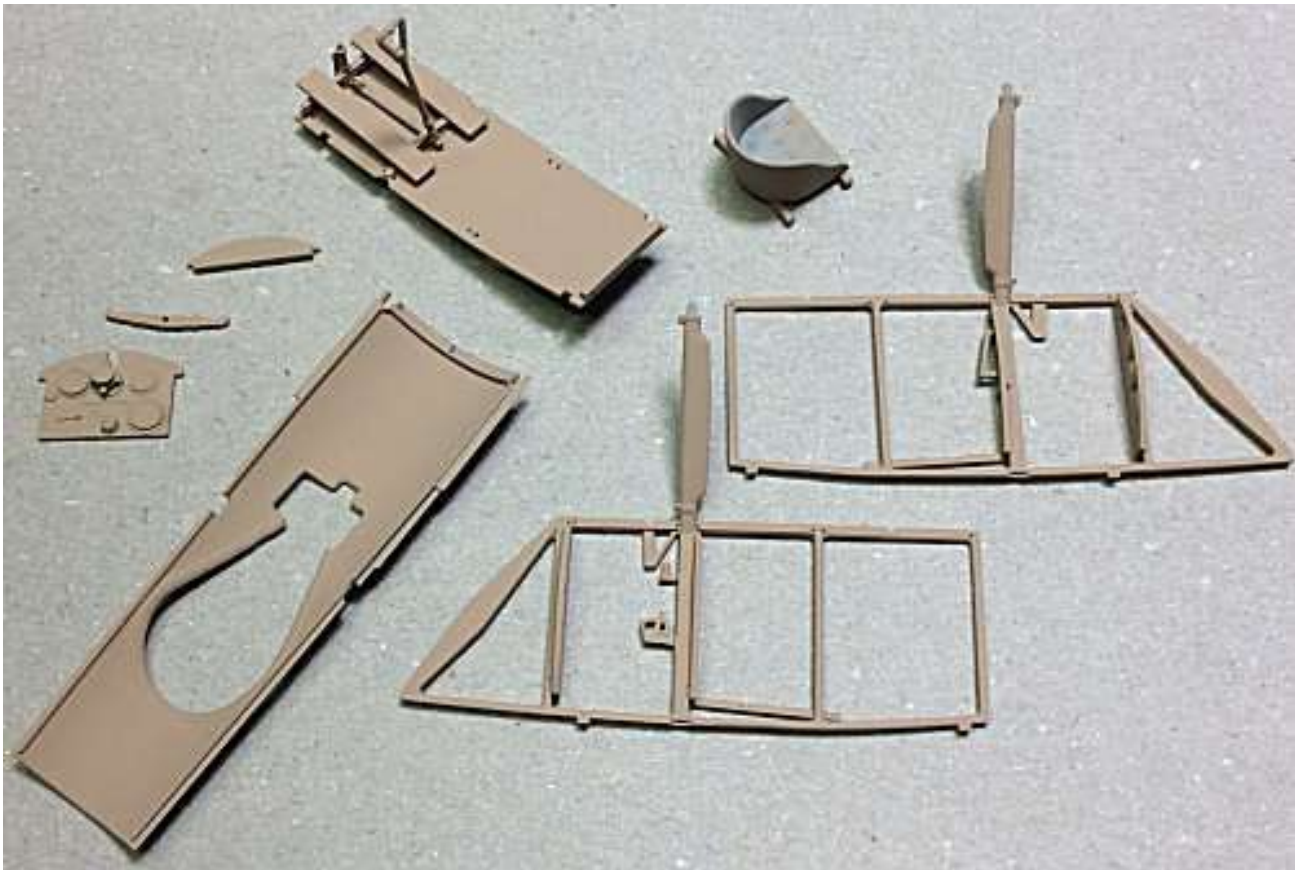

For the next step I use 'DecoArt Crafters Acrylic' paints, either Burnt Umber or Burnt Sienna. These are similar to standard acrylic oil paints, but are water based instead of oil based. This paint is not as thick as oil based paint and is more creamy, so can be brushed and controlled more easily. Also, as it is water based, it's easy to clean your brushes, and if really necessary, can be thinned slightly with water. In addition, the paints dry as quickly as normal acrylic paints, avoiding the disadvantage of using true oil paints, which can take days to fully dry.

Place a small amount of the oil paint onto a non-absorbent surface and using a suitable oil paint brush (I use a slightly curved brush), wipe a small amount of the paint onto the brush. For larger areas, such as decking or panels etc I use a small piece of fine sponge to apply the paint.

Apply the paint to the applicable item, using light strokes and in the required direction. Apply the paint along struts and across instrument panels and other smaller items. This gives variation to the wood effect and for the wing struts, is correct for the direction of the wood grain. If you apply too much paint, just brush or sponge it off immediately before it dries. Although the paint is water based, don't try to thin any applied paint with water as it will lift the paint, which builds up into clumps. If required, a second light coat can be applied. Always wait until a first coat has fully dried before applying a second coat, otherwise the first coat will 'drag' and lift from the surface.

Once painting is complete, clean the brush in water.

Below is an example of the Burnt Umber oil paint applied to a cockpit side frame.



Once the oil paint layers have dried, the final top coats can be applied to give the final effect of varnished wood.

'Tamiya' have 'Clear' coloured Acrylic paints, which are intended to be mixed with either Flat Clear (XF86), Semi-Gloss Clear (X35) or Clear (X22), to give the required finish but with a tint of the added 'Clear' colour. I use the Clear Yellow (X24) or Clear Orange (X26) to add a varnished tint to the clear coat. If using the 'Tamiya' Clear I add 'Mr. Colour' Levelling Thinners, which does improve airbrushing and avoids pooling. Otherwise I use 'Alclad' Light Sheen (ALC-311).

Although it's a lacquer, I've found that it will accept 'Tamiya' 'Clear' coloured Acrylics without any separation, which can happen with other paints. The 'Alclad' lacquers dry fast and provide a good sealing layer over the painted surfaces. When using 'Alclad' sealing coats, the golden rule is to allow the various painted surfaces to dry fully before applying 'Alclad' lacquers.

In this instance, I added a few drops of Clear Yellow (X24) into the 'Alclad' Light Sheen (ALC - 311) and thoroughly mixed it. Only add small amounts to the 'Alclad' in order to control the amount of tint you desire. I increased my airbrush air pressure to around 20 psi to airbrush the sealing coats over the various cockpit items. The first coat usually dries to a more matte finish, which I assume is due to being sprayed onto the oil paint, rather than onto straight acrylic paint. Once this first coat has dried, I airbrushed several coats of just 'Alclad' Light Sheen (ALC -311), which added not only more sealing coats, but more importantly gave the desired semi-gloss 'varnished' finish I was after.

Below is an **example** of the applied 'Alclad' lacquer/X24 mix on the propeller.



NOTE: *Once you are confident using this method of replicating wood finishes, you can vary both the colour of the acrylic base coat and tinting of the sealing coat, to replicate other types of wood used in aircraft construction.*

Once the lacquer coats are thoroughly dry, any detail painting, decals or final weathering can be applied to the parts, as required, prior to fitting them to the model.

PART 3
WEATHERING
(General)

PART 3 - WEATHERING (General)

There are many different types of weathering mediums available now to modellers of aircraft, ships, vehicles and figures, in model of any type. These weathering mediums can be washes based on enamel, clay or ink. Weather pastels, applied by sponge' as well as oil paints of various sorts are also plentiful. Some modellers have even used water colour paints, and pencils. The following are the basic weathering mediums I tend to use on most of my models.

Flory Model clay washes:

The washes I tend to use are the 'Flory Models' Clay Wash 'Grime' and 'Dark Dirt', which come in various shades and consist of a suspended and very fine clay pigment. They are brushed over the surface to be weathered and dry in around 30 minutes. When dry, use either a piece of good, absorbent kitchen roll or a soft brush to remove as much of the clay wash as you need to achieve the desired effect. The kitchen roll can be used dry or very slightly dampened. If dampened, the dried clay is re-activated and the clay wash can be more easily be removed or worked as required.

First I seal the surface with an airbrushed semi-matte clear coat, such as 'Alclad' Light Sheen (ALC-311), which dries quickly. A gloss coat tends to stop the clay wash 'gripping' the surface when it is applied and it can run off or just puddle. A more matte coat can cause the clay wash to 'grip' too much, making it difficult to remove or even to wash it off completely.

NOTE 1: The more glossy the applied sealing coat is, the more the chance there is that the applied 'Flory' clay wash will not spread fully, but rather form puddles or beads of wash. If this happens, add a few drops of ordinary kitchen washing up liquid to the clay wash. This will break the surface tension of the wash, allowing it spread fully.

NOTE 2: Always decant the amount of clay wash you need, rather than dipping the brush directly into the wash bottle. Dipping into the wash bottle can transfer contaminants from the brush into the wash, will can cause the wash to become thick and unusable.

NOTE 3: When a sealing coat is applied over areas treated with clay wash weathering, the intensity of the applied wash tends to darken. This should be considered when removing the clay wash, otherwise the final effect may appear too dark.

NOTE 4: 'Flory' current range of washes are: Dark Dirt, Grime, Black, Light (white), Mud, Sand, Rust and Concrete. All of these washes can be mixed to create many colour shades for different weathering finishes.

To apply the clay wash is just a matter of brushing all over the surface to be weathered. It doesn't matter really how much is applied as it can be left on for any period, as it is easily removed without any effect on the surface underneath. If you don't achieve your desired effect, you can wash it all off and start again. Use a soft brush or absorbent kitchen roll, which are dry or **very slightly** dampened, to brush or wipe off the clay wash in the direction of airflow over the model. Even then, dab them onto a dry piece of the paper, until they are almost dry. Any wetter and you'll find that you are removing too much of the clay wash. If that happens you can re-apply the wash and start again. If you're not happy with the final effect, you can easily remove the clay wash by brushing with a wet brush or even airbrush water over the surface. Dry off the surfaces washed and then re-apply the clay wash and try again until you are satisfied. The technique is to 'damp' brush or wipe over the surface to re-activate the clay wash and at the same time, to smear it over areas that had no clay wash. It'll dry within 30 minutes. Then very lightly brush and/or use a piece of damp absorbent paper to remove as much you want until you get the desired effect. Once finished, run the brush under a tap to rinse out any residual clay pigments. Finally, seal the surface with your chosen clear coat, which will seal in the applied clay wash.



Chipping effects:

To give the effect of chipped and weathered paint/varnish to metal engine cowls and forward fuselage panels etc, chipping fluids can be used. To achieve this effect, first prime the areas with a suitable primer then airbrush the metallic finish desired. Once dry, a chipping fluid, such as 'AK Interactive' Medium Chipping fluid or 'Vallejo' chipping fluid is airbrushed over the painted areas. An alternative is to use a cheap hair spray. This forms a barrier which will allow the top coat to be chipped off. Finally the required top coat colour is applied.

Once fully dry, moisten the top coat with water, which softens the paint. Then with a cut down (stiff) brush and wood cocktail stick, gently teased off the top coat paint. Take care when doing this as 'too much chipping' can't really be covered up. In that event you would have wet the top coat and remove it all with an old toothbrush or similar and then when dry, re-spray the top coat and try again. Once the desired effect was achieved, I sealed the surfaces with an airbrushed coat of 'Alclad' Light Sheen (ALC-311).



'Tamiya' Weathering Master sets: Each of these 'Tamiya' produced weathering sets contain three 'tablets' of different colours and an applicator, which has a brush on one end and a sponge on the other. The tablets have a wax look and feel and can be applied onto painted surfaces to reproduce various finishes. It's best to use these as the final surface treatment, as being a 'Wax', any treated surfaces can't be painted or sealed.



Pigments: Pigments, such as those produced by 'Flory Models' or 'Humbrol' are effectively very fine 'dusts', which can be applied to a model to re-create dust, dirt, stains etc. They can be applied by dry brushing or mixed with other mediums to create paintable solutions.



Washes: Washes can be applied to either enhance panel lines etc or to add a 'filter' of colour onto a painted surface. They can be purchased ready made from various manufacturers or can be 'home made' using such as oil paints with a suitable thinning agent. I tend to use 'AK Interactive' products.



Water colour pencils:

Water colour pencils can be used to add weathering detail. The colour s applied to the model part then brushed gently with a brush, slightly dampened with water. This dilutes the pencil marking, allowing it to be faded as desired. 'AK Interactive' produce these 'weathering' pencils, which are marketed specifically for the modeller, although other artist water colour pencils can be used, such as 'Derwent' Inktense 24 ink pencils.



Oil paint: A technique used more frequently now is oil paint 'dot and drag'. Basically an oil paint of the desired colour is placed onto a piece of cardboard, which over a hour or so, soaks out the oil in the paint, leaving a drier pigment. The pigment is 'dotted' onto the painted surface where it is required then dragged with a brush previously wetted with 'Tamiya' X20 enamel thinners then wiped virtually dry.

Softly 'flick' the brush to drag the pigment in the direction required, which will blend it in a thin layer.

The amount of pigment left showing depends on the effect you require. Always keep the brush wiped clean to avoid a build up of pigment and remoisten and wipe dry often. The more paint you drag, the less pigment is left showing. Blending different coloured pigments can create stains from smoke/gun blast, rain marks/runs, dirt/dust and oil/fuel stains.

A good quality oil paint and thinners are essential to produce a good finish. Some quality oil paints can be too 'gritty' when leached of oil, so I use 'Abteilung 502' oil paints and 'Tamiya' Enamel thinners (X20).



PART 4
DECALS
(General)

PART 4 - DECALS (General)

Standard decals:

The supplied markings decal sheet and the optional 'lozenge' decals sheets are not 'cookie cut' to the required shapes, but are part of the overall carrier film on the sheet. Therefore you will need to carefully cut the individual decals from the sheet. The decals appear not to be laser

printed, as with for example 'Cartograph' decals, and backing sheet is thicker than standard decal sheets. This makes it difficult to achieve a clean cut around the decals. The decals are not of the best quality, which is to be expected from a 'limited run' kit of this type and given that they have to be carefully cut out from the sheet may make the end result less than favourable.

One alternative to using these decals is, where possible, is to source replacements from commercial retailers or from your 'spares' collection if you have one. This would only apply to the larger 'standard' markings as the smaller and specific model decals are unique and would still need to be used.

A second alternative for the larger markings would be to create masks and airbrush the markings, although this would require specific masks and is not a method advised for the less experienced modeller. Again the small and specific models decals would still need to be used.

NOTE: *The following is **applicable only** for decals on a **painted surface**. If decals are to be placed on top of **previously applied decals**, the decal setting solutions may 'eat' into the previous decals. In this case a sealing coat of either 'Alclad' Gloss (ALC-310), 'Alclad' Aqua Gloss (ALC-600), Tamiya' Clear (X22) or 'Johnson' Pledge Floor Care finish should be airbrushed over the first decals, to provide a barrier against the setting solutions.*

Ensure the painted surface is smooth and free from any surface imperfections.

Airbrush a sealing coat of 'Alclad' Gloss (ALC-310), 'Alclad' Aqua Gloss (ALC-600), 'Tamiya' Clear (X22) or 'Johnson' Pledge Floor Care finish, to provide a smooth surface.

NOTE: *'MicroSet' solution softens the decal to allow it to conform to the painted surface. Do not attempt to move the decal too much or it may tear.*

Wet the area using a light coat of 'MicroScale' **MicroSet** solution.

Apply the decal after it has soaked in 'warm' water enough to start to loosen the decals from its carrier backing.

Carefully move the decal into the correct position.

Carefully press out any residual water from the decal by either pressing with a tissue or by gently rolling over the decal with a cotton bud.

NOTE: *'MicroSol' solution will soften the decal to allow it to conform fully to the painted surface. The solution usually causes the decal to wrinkle, but this is normal as the decal semi-dissolves to the surface. Once the solution has been applied, never try to disturb the decal as it will tear. Leave the solution for several hours to do its job, after which the decal will return to a smooth surface, but conformed fully to the painted surface.*

Wet the decal surface with a light coat of 'MicroScale' **MicroSol** solution.

Leave the solution for several hours to fully dry and set the decal.

Once fully dry and set, airbrush a sealing coat over the decal, dependant of your desired finish. I tend to use either 'Alclad' Light Sheen (ALC-311) lacquer or 'Tamiya' Semi Gloss (X35).

Once the decal is correctly positioned, use a flat brush to brush the water out from under the decal, working from the centre of the decal out towards the edges. I then use a dry cotton bud in the same manner. Finally, wearing cotton gloves, I apply slight pressure and slide my fingers across the decal to finally push the decal onto the surface.

Once the decals have been applied I airbrush a sealing coat of either 'Alclad' Clear Coat Gloss (ALC-310) lacquer), 'Alclad' Aqua Gloss (ALC-600), 'Tamiya' Clear (X22) or 'Johnson' Pledge Floor Care finish over areas of decals where more decals are to be applied.

Once the decals have been applied and are dry I airbrush a final sealing coat of 'Alclad' Light Sheen (ALC-311) or 'Tamiya' Semi-Matt (XF35) over the decals.

To 'knock back' the sheen for applying weathering effects (refer to Part 3 of this build log), for example 'Flory' clay washes or oil paint, I airbrush a sealing coat 'Alclad' Light Sheen (ALC-311) mixed with Flat (ALC-314) at a 3 to 2 ratio.

'Aviatic' linen effect decals:

The 'Aviatic' decals are different in both production techniques and application to those of the more traditional decal manufacturers. Traditional decals are normally created using processes such as silk screen printing and are pre-shaped for the particular model markings. When placed in warm water they will detach from the backing sheet and can then be slid onto the model surface and when they are correctly positioned, wiped with a semi-dry brush or cotton bud etc, to expel any water from under the decal. Once fully dry, decal softeners, such as 'MicroSol' and/or 'MicroSet' can be applied, if necessary, to 'weld' the decal to the model surface. Finally a sealing coat of acrylic or lacquer gloss, semi-matt or flat is applied over the decal, to seal and protect the seal and protect the decal.

However, 'Aviatic' decals are laser printed onto a very fine carrier film and although this film is thin, the decals are remarkably resilient and somewhat 'stretchy' when being applied. This allows them to be more easily moved and positioned before being finally applied. Also with most other decals, I've used softeners to help the decals conform to surface irregularities and contours, which is something I've found is not really required for 'Aviatic' decals, due to the nature of the carrier film. In addition, the decals need to be cut out from the sheet, so care is required to cut the decals accurately to avoid leaving gaps, especially at the edges, where the white base colour will show. That said, minor gaps may be able to be covered with weathering. For more information, refer to the 'Aviatic' instruction sheet supplied with the decals.

'Aviatic' decals are laser printed onto either 'clear' or 'white' backing, the 'clear' being dependent on the base coat you apply and the finished effect you desire. The decals are supplied with very clear instructions on their application, including when to add pre-shading to the base coat, where desired, before you apply the decals. For this model I chose to use the 'clear' decals, in order to show the linen effect more visibly.

Application:

If the decal is to be applied without a coloured undercoat (green, brown etc), first airbrush a primer coat of 'AK Interactive' primer and micro-filler (White - AK759) on all of the surfaces to have the decals applied.

NOTE: *'Silvering' is caused by air being trapped in the rough surface of the paint, such as on a matte finish, which after the decal is applied and dries, causes silver sheen patches showing in the decal ('silvering').*

Once dry, check the surfaces for any imperfections, such as trapped dust or raised areas of paint, which will cause 'silvering' under the decals. Any surface imperfections found should be carefully polished out.

Airbrush at least two light sealing coats of either 'Alclad' Clear Coat Gloss (ALC-310) lacquer, 'Alclad' Aqua Gloss (ALC-600), 'Tamiya' Clear (X22) or 'Johnson' Pledge Floor Care finish (similar to 'Future'), all of which will form a gloss surface for applying the decals.

NOTE: *The surface must be pre-wet with like warm water with. Care needs to be taken when you slide the decal from the backing sheet and onto the model surface, as the thin decal can fold over on itself.*

Soak each decal in warm water for approximately 20 seconds.

Wet the surface of the model where the decal is to be applied.

Carefully slide the decal onto the wetted surface. Make sure the decal does not fold over on itself.

Align the decal to the shape of the model part.

Using a broad, soft brush, brush the decal from the centre outwards to remove any water from under the decal.

Adhere the decal to the model part surface by either pressure rolling over the decal with cotton buds or, as I do, by wearing lint free cotton gloves and rubbing the decal with your fingers.

Check to make sure the decal is in full contact with the surface of the model part and that there are no areas exhibiting 'silvering' (trapped air under the decal). If so, gently prick through the decal and apply water then press out the water to adhere the decal back onto the model part.

Also check that there are no lifted decal edges around the model part.

Allow the decal to fully set, preferably overnight. Where decals have been applied to large areas, gentle heating using a hair dryer can accelerate the decal setting time.

Where decals cover location holes or other openings, prick or cut through the decal into the hole or opening then apply 'Tamiya' X20A thinners, which will soften and adhere the decal into the hole or opening. Using X20A can also conform decals around curves edges etc.

Protect and seal the decals by airbrushing a sealing coat over the decals. If more decals are to be added onto the applied decals a gloss sealing coat should be used. Otherwise a sealing coat of the desired finish can be applied, which should also be done once all of the required decals have been applied.

PART 5

RESIN (General)

PART 5- RESIN (General)

The reason for creating resin kits is that in years gone by, resin kits were able to produce much finer detail on kit parts than the plastic kit equivalents. Even today, there are many producers of resin kits and particularly after market replacement parts. However, plastic kit manufacturers have come a long way now and kits, such as those from 'Wingnut Wings' and 'Copper State' are equal to, if not better than resin kits. Manufacturers of resin kits these days tend to make kits to order or have 'limited' runs, although aftermarket parts are usually readily available. Working with resin does present different challenges to the modeller, especially if it's the first time of building a resin kit. The properties of resin differ radically to those of plastic kits.

Below I have listed what I have found to be the primary differences for resin kits from plastic kits:

1. When resin kits are cast in their moulds, a release agent is applied to enable the cast resin parts to be more easily removed, which is similar to plastic kit moulding. This release agent can leave a film on the surface of the kit parts, which, if not removed, can prevent paint or adhesives from adhering to the surfaces. The easiest way to remove this film is to carefully and fully wash all of the model parts in warm soapy water, using an old, soft tooth brush, then rinse all of the parts thoroughly and leave to dry. Alternatively wipe the parts with isopropyl alcohol (e.g. 'Tamiya' X20A thinners).
2. Resin, by its nature, is very brittle and can be damaged or broken easily, especially when handling small parts. This is particularly evident when separating the individual items from the resin cast. The best way to remove item is to cut them away with a razor saw, then clean them up afterwards.
3. Once removed from the resin cast, parts will normally have 'resin flash' around or amongst parts, especially small items. This is easily removed with a sharp scalpel blade. Heavier residue can be scraped, filed or sanded away.
4. Plastic kits are assembled using solvent adhesives, which melt the surface where it is applied and 'weld' the joint together. Resin however will not react to this type of adhesive and can really only be glued using CA adhesive. This adhesive reacts to moisture in the air and on the surface to be joined. As most people know, it will also bond skin to whatever it touches, if the skin has CA adhesive on it. Obviously extreme care needs to be exercised when assembling resin kits using CA adhesive.
5. Cutting, sanding and drilling resin will create swarf and more importantly, resin dust. The dust in particular is dangerous, especially if inhaled. Therefore always vacuum the working area, and yourself, regularly. If you have a face mask or filtered respirator and find you can wear it whilst working, then do so. Resin can easily be drilled or scraped, but remember how brittle resin is when it is being handled.
6. It is not unusual to find imperfections in resin cast parts, such as surface blemishes, small 'blow' holes or ragged edges. This can be common on some resin kits. These imperfections can be rectified by sanding/polishing and/or filling with modelling putty, then sanding/polishing.
7. Generally CA adhesive is supplied as 'instant bond' adhesive, but there are some manufacturers, such as 'VMS Fleky', that supply CA adhesive as standard, thin, slow and specific resin adhesive. Whichever adhesive is used you must ensure parts are correctly positioned and aligned before applying the adhesive. Trying to separate mis-aligned parts once the adhesive sets will prove very difficult and may result in irreparable damage to the parts.

NOTE: To separate resin parts from the thin moulding backing sheet, use sharp scissors or a scalpel blade. To separate larger parts from the moulding base block, use a fine modellers saw. The saw I use has a double sided and fine 'drag' saw blade and with its holder is available from 'RB Productions'.

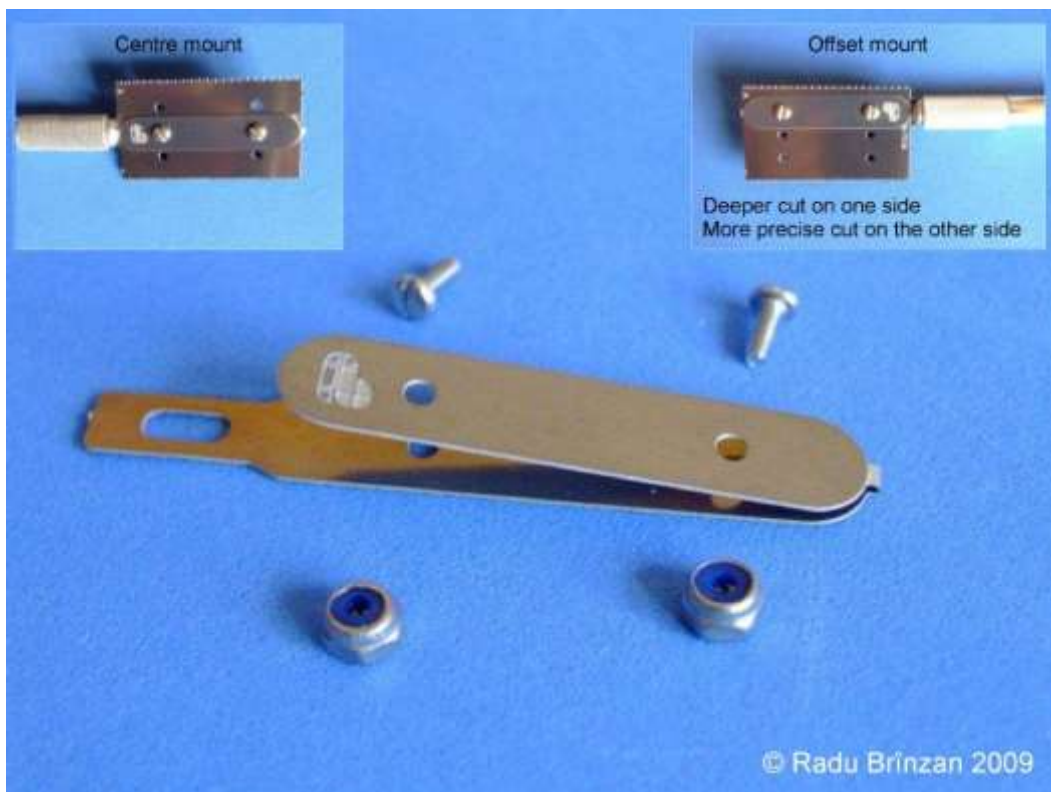
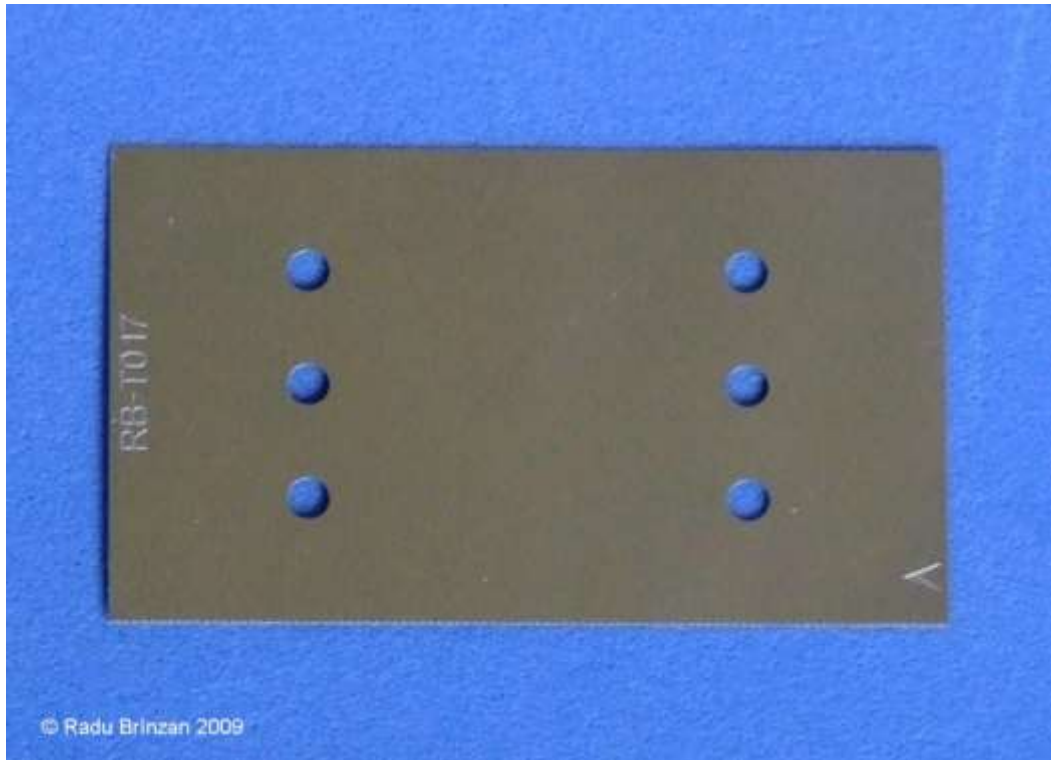

PART 6

RIGGING

PART 6 - RIGGING

General:

The first thing to check is that you have already drilled out the rigging attachment points. Most models have these located on the model, but it's best to carry out research in reference books or research on line before drilling. Some modellers use micro drills manufactured for drilling printed circuit boards etc and these drill bits sometimes have identifying coloured collars fitted to the drill shanks. I have found that care needs to be taken when using these drills, as they are sharp and instead of easing their way into the plastic of the model, they tend to bite in and effectively 'cork screw' their way in, which causes jamming and lots of broken drills. This is not only expensive but can leave broken drill bits in the model, which are virtually impossible to extract. An alternative is to use High Speed Steel (HSS) drill bits, which are cheaper and have less 'bite' when in use, although again, they are very fragile and can very easily be broken.

Some modellers drill through the wings etc of the model and rig by pulling through the rigging line/EZ thread etc, gluing in position and then rubbing down the exposed line 'tag' and then re-painting that area. I prefer to drill only part way into the plastic and attach the applicable rigging fixture with CA adhesive.

With your research complete and all necessary holes pre-drilled, the rigging can start. For the primary rigging, such as flying and landing wires and flight control cables I use mono-filament (fishing line) of 0.08 and 0.12 mm diameter. These are effectively transparent but do give a look of steel, without the need of painting or colouring with a gel pen. The turnbuckles used are either sintered metal or resin and obtained from 'Gaspatch Models'. Although the newer resin turnbuckles are better detailed, they are resin and therefore can break if stressed in the wrong direction. If in doubt, use the metal versions, which are much stronger.

The basic aircraft external rigging is shown in the following illustrations, taken from the 'Special Hobby' instruction manual, pages 8, 9 and 10. The aircraft is rigged with round, wire wound wires with adjustable turnbuckles.

The kit supplies photo-etch rigging points, these are difficult to secure in position so will be replaced with 'GasPatch' turnbuckles and copper wire anchor points.

The rigging materials to be used are:

'Stroft GTM' 0.08 mm diameter mono-filament (flight control cables)

'Stroft GTM' 0.12 mm diameter mono-filament (general rigging)

'GasPatch' 1:48th scale metal turnbuckles and 0.125 mm diameter wire anchor points.

'Albion Alloys' 0.4 mm (NST04) and 0.5 mm (MBT05) diameter tube.

External rigging - description:

NOTE: *This aircraft did not have ailerons fitted to the trailing edge of the wings to control the Aircraft when banking left or right (roll). Instead wing warping was employed to twist the outer area of the wings to roll the aircraft.*

Wing warping wires:

Three pairs of wing warping wires were fitted:

Control wires:

A pair of control wires exited the cockpit from each side, through an opening in the fuselage side, just above the lower wing roots. One wire was attached to the underside of the upper wing, inboard from the inner, rear interplane struts. The second wire was similarly attached, but at the outer, rear interplane struts. Turnbuckles were fitted to the wires at the interplane struts.

Reaction wires:

A pair of continuous wires were attached to the upper surface of the lower wings, inboard from the bottom of the outer and inner rear interplane struts. These wires were routed diagonally up and over pulleys (fitted to a cross bar located under the centre section of the upper wing) to the same locations on the opposite lower wing. Turnbuckles were fitted to the wires at the interplane struts.

Operation:

Example of banking (rolling) the aircraft to the left:

As the pilot moved the control column to the left, the pair of control wires at the left upper wing would be pulled causing the wing to twist downwards. This movement of the upper wing was transmitted through the interplane struts to the lower wing, which moved downwards, causing the reaction wires to be pulled. This pulling action was passed by the reaction wires across the pulleys at the upper wing to the right lower wing, which was pulled upwards. This movement of the right lower wing was transmitted through the interplane struts to the right upper wing, which was able to move upwards as its control wires were not being pulled by the control column (not in tension).

The overall effect was that the left wings twisted downwards and the right wings twisted upwards, due to the resistance to airflow over the wings, forcing the left wings down and the right wings up, rolling the aircraft to the left. The opposite actions would roll the aircraft to the right.

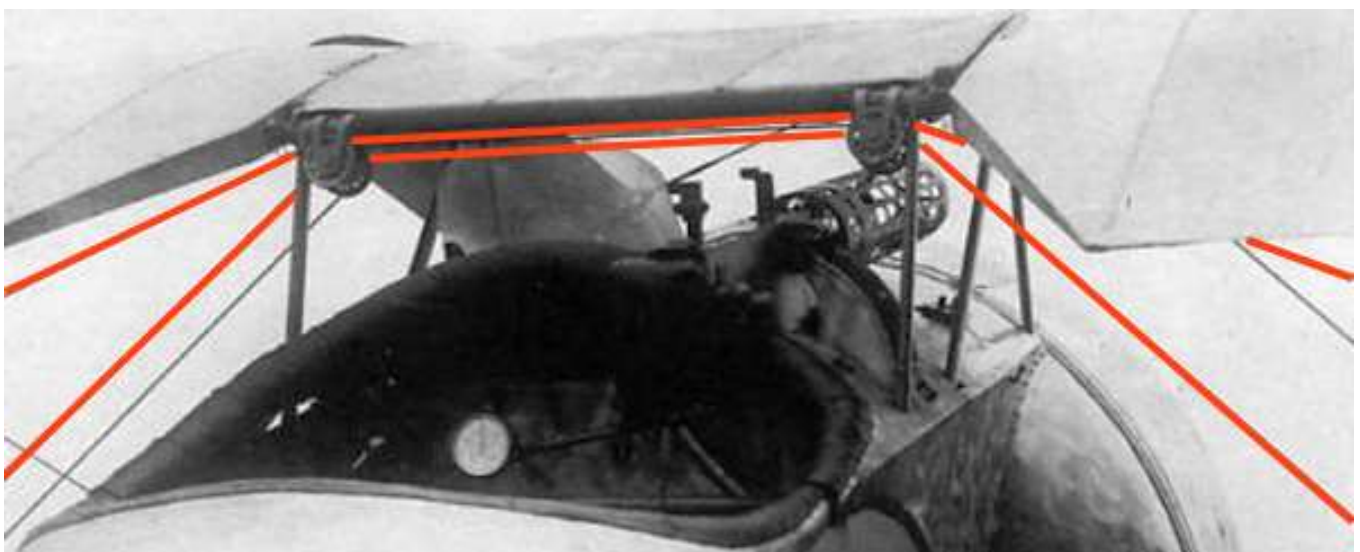

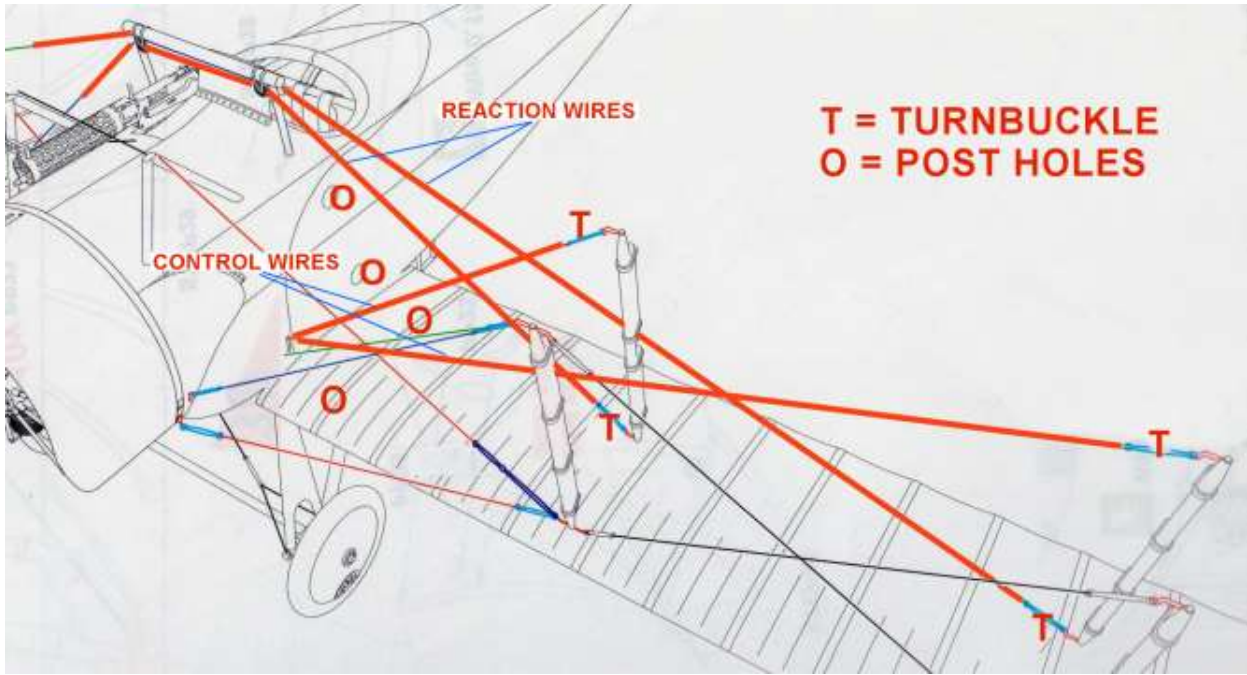

Flying wires:

Both sides of the aircraft were fitted with three flying wires, which were to restrain the wings during flight.

A single wire was attached to the sides of the fuselage, forward from the wing warp control cables exit port and above the lower wing roots. These wires were routed diagonally up and attached to the underside of the upper wing, inboard from the top of the inner, forward interplane struts. A turnbuckle was fitted at the interplane strut.

A second wire was attached to the forward sides of the fuselage, just under the bottom of the main engine cowl retaining strap at the rear of the cowl. These wires were also routed diagonally up and attached to the underside of the upper wing, inboard from the top of the inner, forward interplane struts. A turnbuckle was fitted to the wire close to the fuselage.

A third wire was attached to the upper surface of the lower wings, outboard from the bottom of the inner, forward interplane struts. These wires were routed diagonally up and attached to the underside of the upper wing, inboard from the top of the outer, forward interplane struts. A turnbuckle was fitted to the wire at the base of the inboard interplane strut.

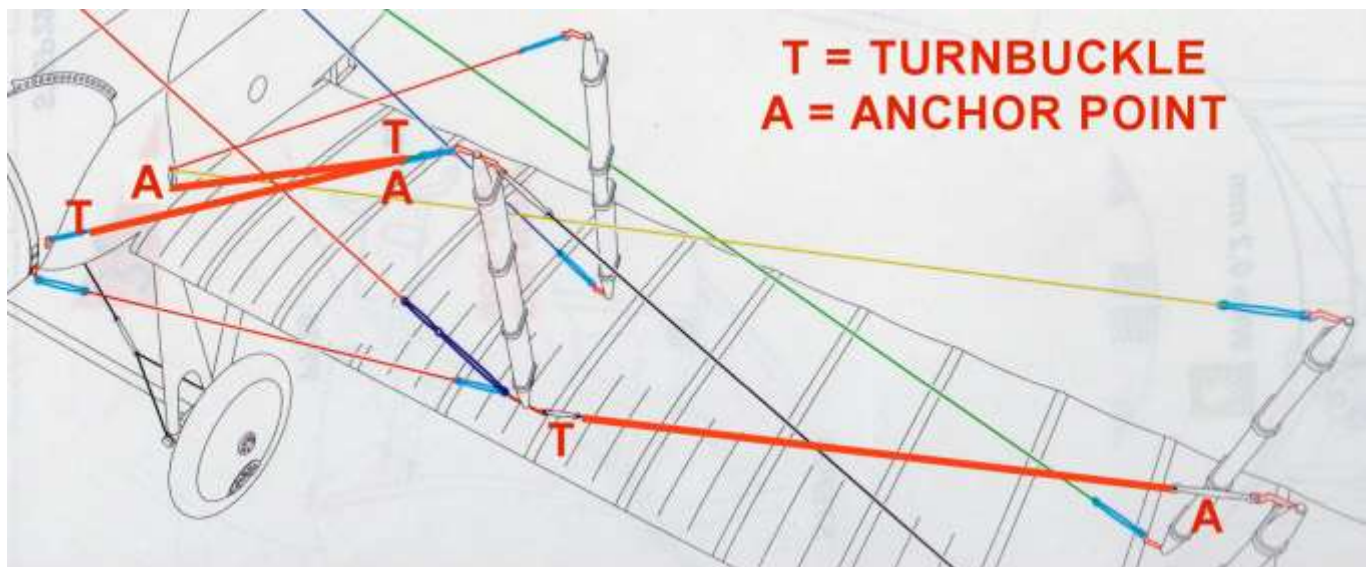

Landing wires:

Both sides of the aircraft were fitted with two landing wires, which were to support the wings when the aircraft was on the ground.

A single wire was attached to the underside of the upper wing, outboard from the top of the fuselage cabane 'V' struts. These wires were routed diagonally down and attached to the upper surface of the lower wings, inboard from the bottom of the inner, forward interplane struts. A turnbuckle was fitted to the wires at the inboard interplane strut.

A second single wire was attached to the underside of the upper wing, outboard from the top of the inner, forward interplane struts. These wires were routed diagonally down and attached to the upper surface of the lower wings, inboard from the bottom of the outer, forward interplane struts. A turnbuckle was fitted to the wires at the outer interplane struts.

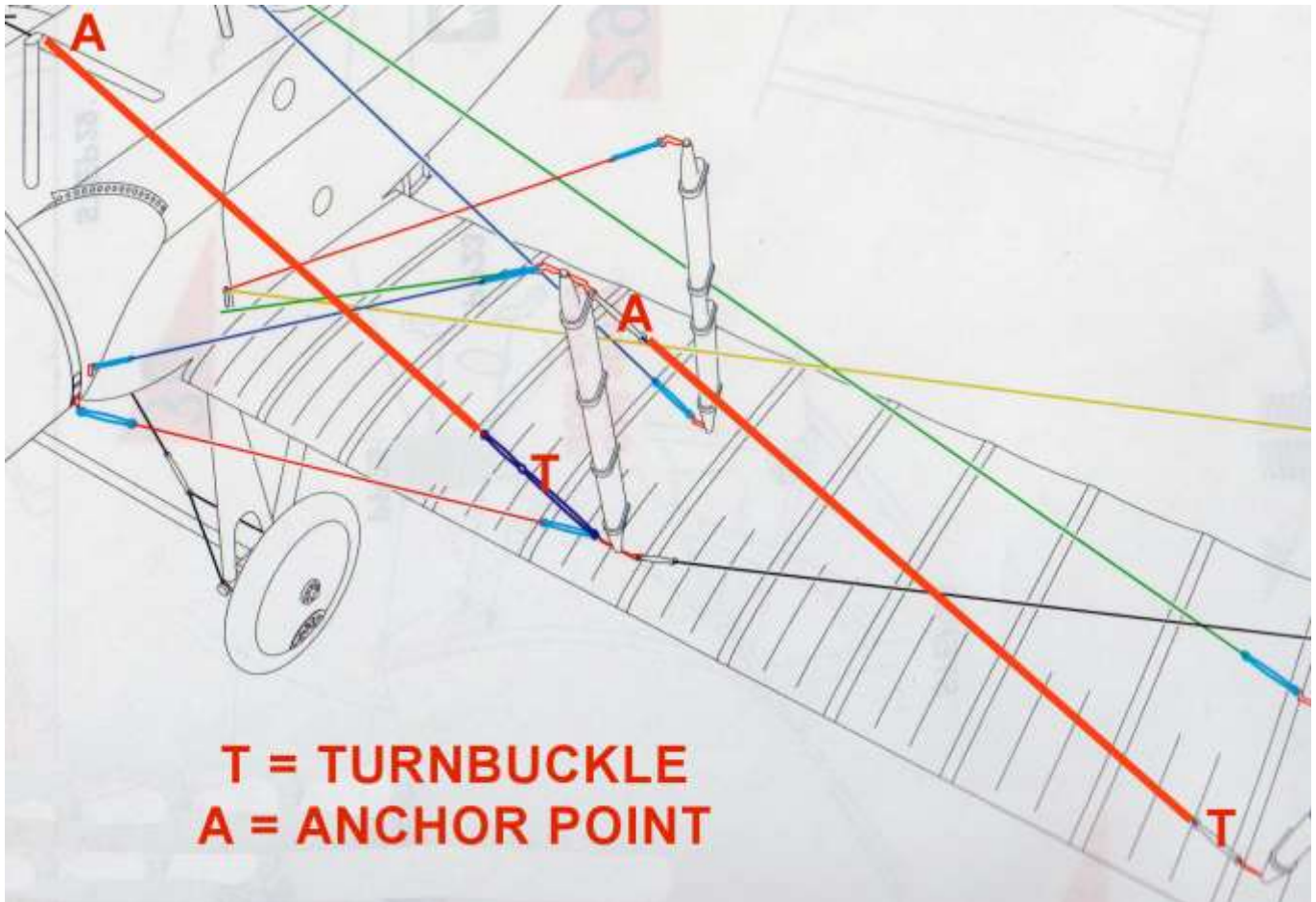

Drift wires:

Both sides of the aircraft were fitted with single drift wires, which were to counteract the tendency of the wings to be pushed back by the airflow during flight.

A single wire was attached to the sides of the fuselage at the bottom of the rear of the engine cowl. These wires were routed across to the upper surface of the lower wings, inboard from the bottom of the inner, forward interplane struts. A turnbuckle was fitted to the wires at the fuselage.

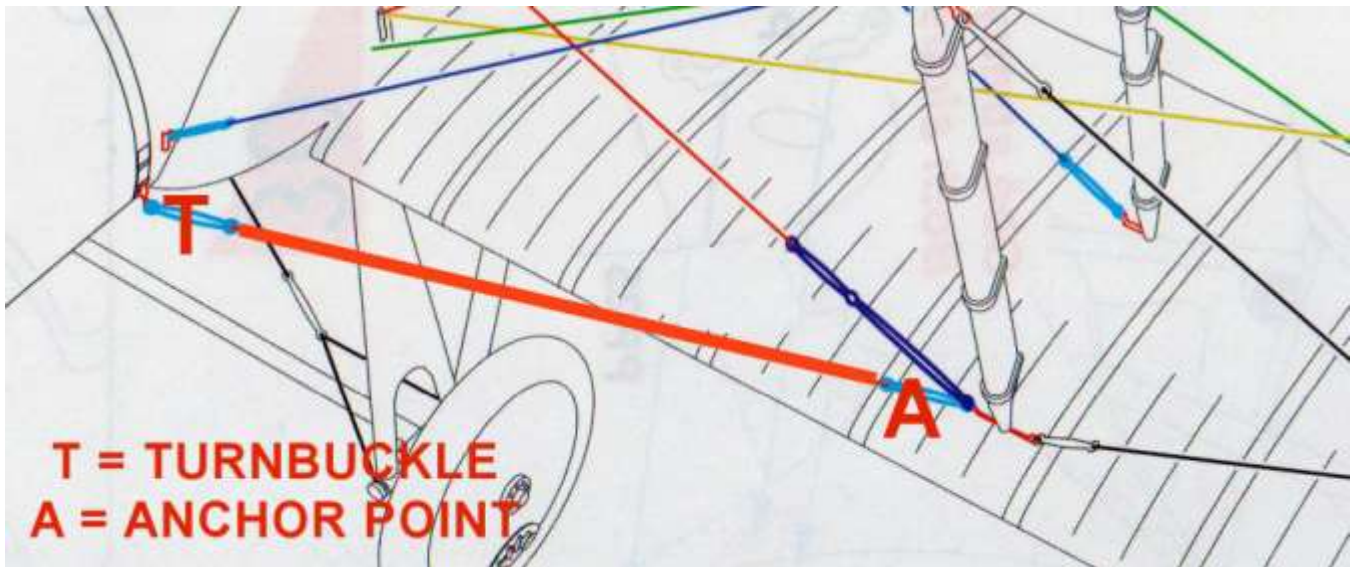

Cabane strut bracing wires:

Two single bracing wires were attached to the underside of the upper wing, inboard from the tops of the fuselage cabane 'V' struts. According to the kit instructions, these wires were routed diagonally down and crossed each other and attached to the fuselage, inboard from the bottom of the fuselage cabane 'V' rear strut. Turnbuckles were fitted at the upper wing.

NOTE: *These wires were employed on the M17 prototype aircraft, which did not carry weapons during testing. Once a machine gun was fitted, it would possibly obstruct the bracing wire attachment to that side of the fuselage. If that was the case, it's possible that the wires were attached more centrally through the fuselage onto the fuselage structure and the wire on that side would pass inboard of the machine gun and not being obstructed.*

Test fitting the cabane strut and machine gun then using thin rod to gauge the angle of the bracing wire from the upper wing, proved that the cooling jacket on the weapon obstructs the routing of the wire. Therefore I chose to add the fuselage attachment holes either side of the fuselage seam join, not at the base of the rear cabane struts.

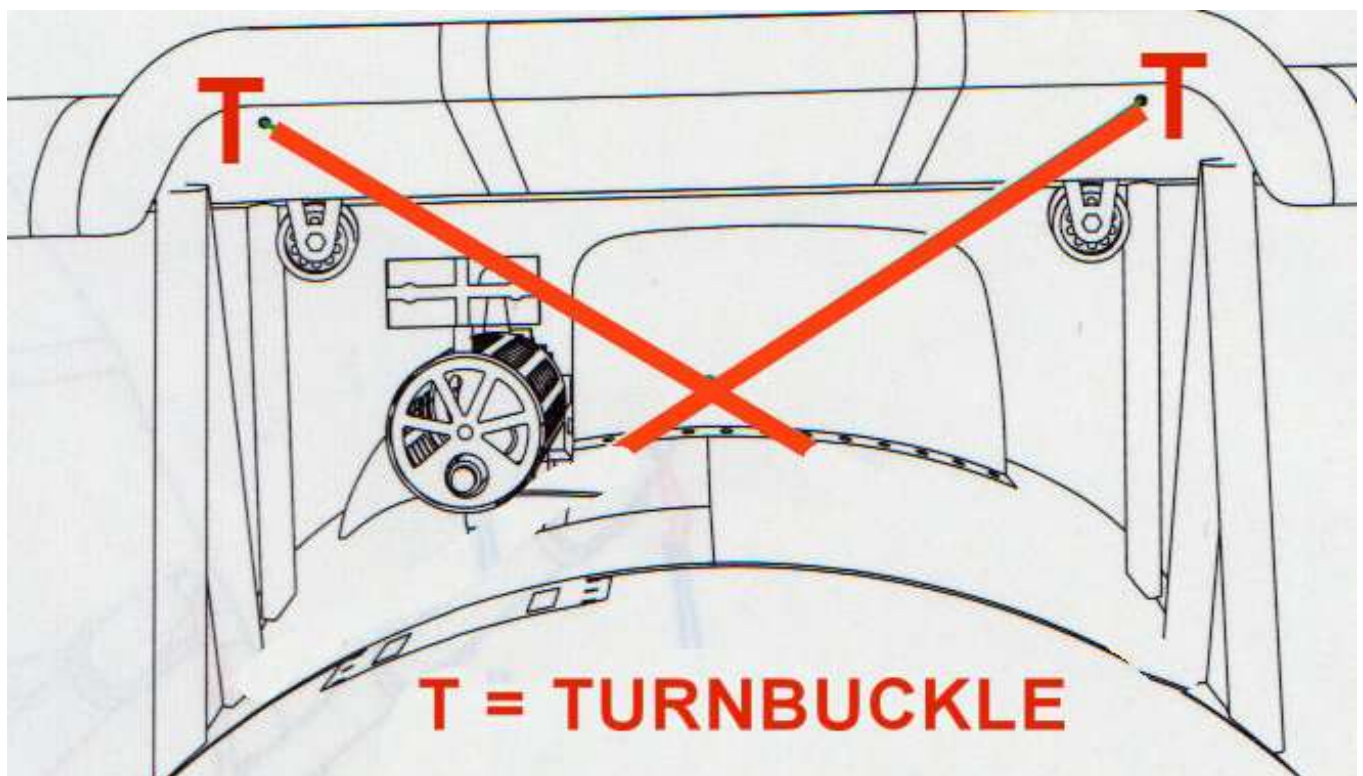

Rudder control:

A single control cable was attached to each end of the pilot's rudder bar. These two cables were routed rearwards through the fuselage to exit through ports in the top, rear of the fuselage. Each cable passed rearwards to its side of the rudder, where it was attached to its rudder control horn. It's not clear where turnbuckles would have been fitted to these wires, but it's probable they were fitted to the cables at the control horns.

As the pilot pushed the rudder bar left or right, one control cable would pull on the rudder and the other not, causing the rudder to turn in the pulled direction and yaw the aircraft left or right.

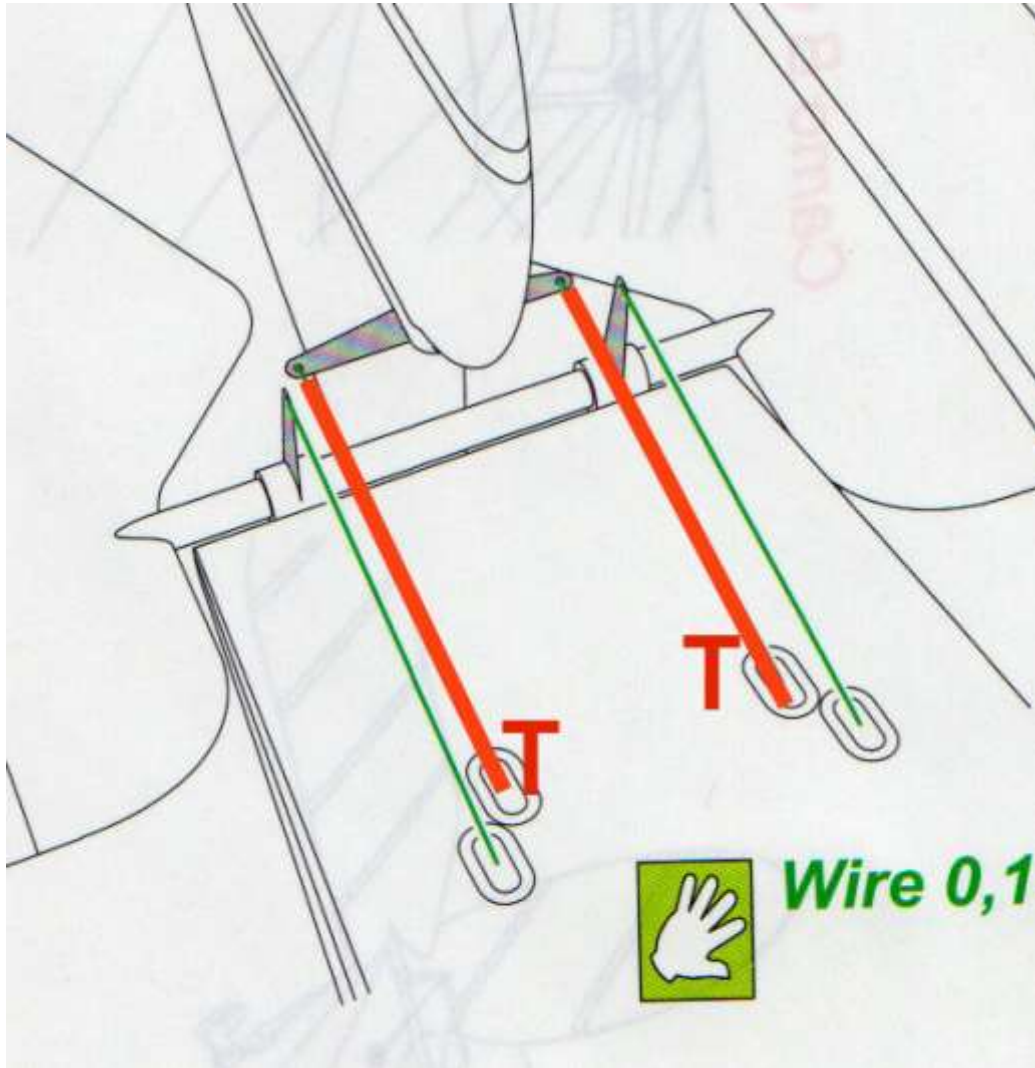

Elevator control:

Two pairs of elevator control cables were attached to the cockpit control column. These two cables were routed rearwards through the fuselage to exit through ports in the top and bottom at the rear of the fuselage. The upper cables on each side of the fuselage passed rearwards and were attached to the upper elevator control horns on their side of the elevator. Similarly the lower cables were attached to the lower elevator control horns on their side of the elevator.

It's not clear where turnbuckles would have been fitted to these wires, but it's probable they were fitted to the cables at the control horns.

As the pilot moved the control column forwards or rearwards, either the upper or lower elevator control cables would pull on the elevator and the other not, causing the elevator to be lifted or lowered. This would cause the aircraft to pitch up or down (climb or dive).

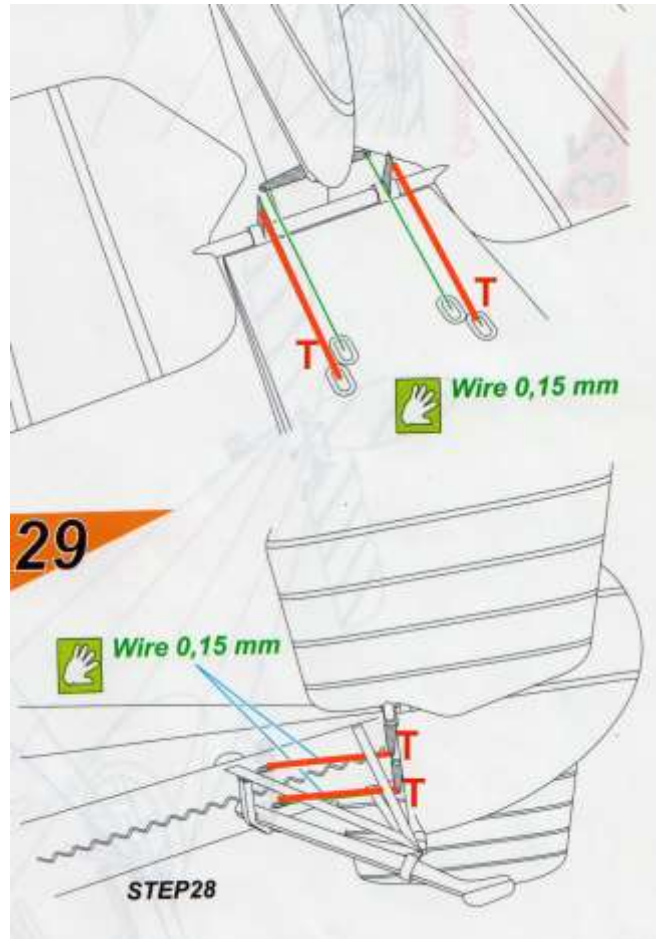

Landing gear bracing:

Two single bracing wires were attached to the underside of the fuselage, inboard from the tops of the forward landing gear struts. These wires were routed diagonally down and crossed each other to be attached to a second wire. These wires formed a 'V', the wires passing either side of the main axle to be attached to the front and rear ends of the lower bars of the landing gear axle. Turnbuckles were fitted at the intersection of the 'V' shaped axle wires.

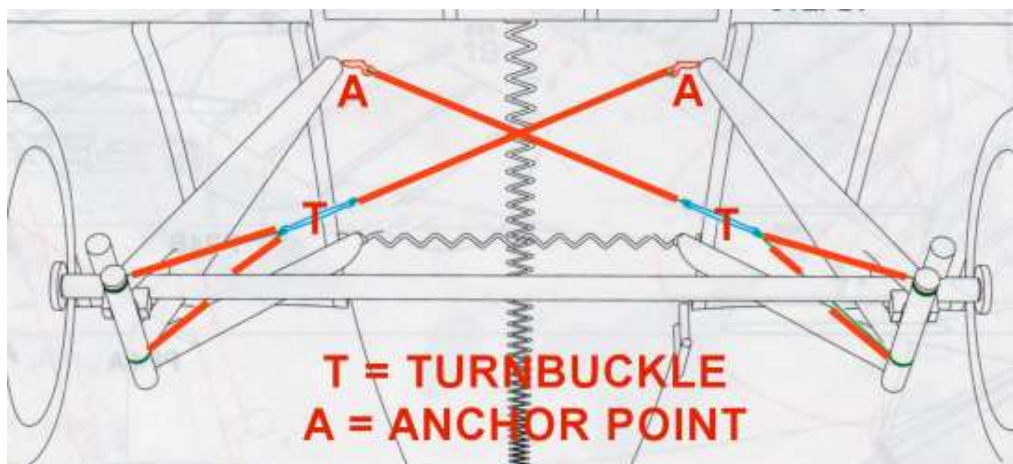

Internal rigging:

References and photographs of the inside of the cockpit are difficult to find, so exact details of cockpit bracing wires, flight control cables, controls etc can't be accurately represented. However, the intention is to add a pilot figure into the cockpit of the this model, which means that in any case, virtually all of any cockpit detail will be hidden from view.

PART 7

ENGINE

PART 7 - ENGINE

The Fokker D.II was powered by the nine cylinder Oberursel U.I (100hp) rotary engine. This engine was effectively a German copy of the French Gnome Delta engine that was being built under licence by Oberursel before the war.

NOTES:

The engine supplied in the kit will be built as designed, except for the following parts.

The supplied photo-etch ignition leads will be replaced with appropriate wire.

The supplied styrene push rods will be replaced with appropriate Nickel-Silver tube.

The kit does not supply spark plugs. These will be create from tube.

The engine propeller shaft will be replaced to fit the replacement 'ProperPlane' propeller.

The two halves of the engine do not have location pegs or associated holes. Therefore the parts need to be carefully aligned during assembly.

Preparation:

Remove engine parts C 20, 23, 24, 38, 40 and 41 from their sprues and remove any residual sprue tags, including the bar across the inside of part C40.

Assembly:

As the valve push rods are to be replaced, cut away the stubs around part C40.

Using the witness marks left, drill holes of 0.7 mm diameter through part C40.

Assemble the engine by cementing the two engine halves (C20 and 24) together, followed by parts C23 and C40 to the front of the engine and part C38 into the rear of the engine.

Cement the cylinder heads (parts C41) into the tops of the engine cylinders, with the valve levers facing the front of the engine.

Modifications:

Spark plugs:

Using the pre-moulded dimples in the rear of the cylinder heads, drill holes of 0.5 mm diameter into each cylinder.

Drill nine holes of 0.3 mm diameter down between the two flanges on the rear hub of the engine. The holes should be drilled vertically into the hub and aligned with the centreline of each cylinder.

Cut short lengths of 0.5 mm diameter tube, such as 'Albion Alloy's' MBT05 or similar.

Cut nine lengths of 0.3 mm diameter copper wire.

Carefully anneal (soften) the copper wire over a heat source, such as a cigarette lighter.

Secure one end of each wire into a tube and secure using thin CA adhesive.

Propeller shaft:

Cut away the propeller shaft from the front of the engine.

Using the witness mark left, drill a hole of 2 mm diameter through the parts C23 and C40 only (not completely through the engine).

Painting:

NOTE: *'Alclad' Lacquer paints contain much finer pigments than acrylic or enamel paints.*

Lacquer paints are also much thinner so rarely need thinning and can usually be airbrush straight from the bottle. To achieve a good finish, lacquer paints should be airbrushed in several light coats, which dry quickly. Layers should build up to achieve the desired finish. Applying too much lacquer paint at one time will cause flooding of the paint with the resultant pooling and runs.

Airbrush 'Alclad' Gloss Black primer or similar over the engine assembly.

Airbrush 'Alclad' Steel or similar over the engine assembly.

Sponge brush 'Tamiya' weathering master set D (Burnt Blue) around the top of the cylinders.

Brush paint the cylinder heads with 'Mr. Colour' Iron (212) or similar.

Brush paint the spark plug tubes with 'Tamiya' Deck Tan (XF55) or similar.

Assembly (continued):

Valve push rods:

Cut nine lengths of 0.6 mm diameter Brass, such as 'Albion Alloy's' MBT06 or similar. The tubes should be cut such that each, when inserted into the pre-drilled holes in part C40, they leave 1 mm of tube protruding.

Cut nine lengths of 0.4 mm diameter Nickel-Silver tube, such as 'Albion Alloy's' NST04 or similar.

Secure the 0.4 mm tubes in the 0.6 mm tubes using thin CA adhesive.

Cut the 0.4 mm tubes such that when its 0.7 mm tube is inserted into its hole in part C40, it can be lifted up to contact the underside of its valve lever on the cylinder head.

Secure each tube assembly in position in part C40 and under the valve lever, using thin CA adhesive.

Spark plugs and leads:

Clear out any paint and primer from the 0.3 mm diameter holes pre-drilled through the flanges on the rear hub of the engine.

Clear out any paint and primer from the 0.5 mm diameter holes pre-drilled through into the cylinders for the spark plug tubes.

Secure a spark plug tube into each of the pre-drilled holes, leaving approximately 1 mm protruding.

NOTE: *Each copper wire fitted in the rear hub should be inserted into the spark plug tube to its right (when viewed from the rear of the engine).*

Insert each copper wire into its pre-drilled hole between the flanges on the rear hub of the engine and secure in position using thin CA adhesive.

Trim the length of each copper wire such that it can be inserted into its spark plug tube and remain straight.

Secure the copper wires into their tubes using thin CA adhesive.

Weathering:

Brush 'AK Interactive' Kerosene wash (AK2039) over the engine.



PART 8

WEAPON

PART 8 - WEAPON

The kit supplied machine gun will be replaced by the 'GasPatch' early LMG 'Spandau' 08.

NOTE: *The 'GasPatch' replacement weapon requires modification to fit into the fuselage (also modified in Part 10 (Fuselage) of this build log.*

Use a flat needle file to remove 2 mm from the underside of the breach block, as indicated by the red area marked on the following photograph.



Using thin CA adhesive, secure the barrel into the cooling jacket (through the hole in the front)

Using thin CA adhesive, secure the rectangular gunsight on the stub at the top, front of the cooling jacket.

Secure the padding block onto the rear of the breech block.

Painting

Airbrush prime the weapon with a gloss black primer, such as 'Alclad' Black ALC-305-60, 'Tamiya' Gloss Black (X18) or similar.

Lightly airbrush the weapon with 'Alclad' Steel (ALC-112) or similar.

Brush paint the ammunition ports on either side of the breech blocks with a mix of 'Mr. Colour' Bronze (215) and Brass (219).

Brush paint the rear padding block with 'Tamiya' Hull Red (XF9 with 'Humbrol' Leather (62) highlights.

Using 'Tamiya' weathering master Set B (Soot), lightly sponge over the weapon to darken the finish, especially around the gun muzzle.



PART 9

PROPELLER

PART 9 - PROPELLER

NOTE: *I chose to replace the kit supplied propeller, but the kit propeller can be used.*

For this build I chose to replace the kit supplied propeller with wood laminated, hand made propeller from Alex at 'Proper Plane', which is supplied pre-varnished and with resin propeller bosses. The kit supplies two types of propeller, both difficult to identify from photographs of the aircraft taken at the time.

Whilst researching the propeller type, I found the photograph below which is of the propeller fitted to the Fokker D.III of Oswald Boelcke, restored after his death. It appears from the logo's on the propeller that it was manufactured by 'Imperial'. However an earlier photograph of Boelcke stood by this aircraft shows that then, the propeller fitted was manufactured by 'Garuda'.

'Boelcke's restored Fokker D.III with 'Imperial' propeller



'Boelcke's Fokker D.III with 'Garuda' propeller

Although this model is of the D.II version, some photographs show these aircraft could have been fitted with the 'Imperial' type propeller.

I chose to replace the kit propellers with a 'ProperPlane' Lang type propeller, which is similar in shape to the 'Imperial' propeller. Also I had spare 'Imperial' logos from a previous 'Wingnut Wings'

NOTE: *The propeller requires mounting onto a 2 mm diameter tube for fitting to the engine propeller shaft.*

Drill out the mounting hole in the propeller and the **rear** resin mounting plate to 2mm diameter.

Cut a short length of 2mm diameter tube, such as that from 'Albion Alloy's or similar.

Insert the tube into the hole in the propeller from the rear. Check that with the tube flush (or just below) the front of the propeller boss, the tube protrudes from the rear by 5 mm. If necessary, file the tube end to achieve 5 mm protrusion.

Airbrush a light coat of 'Tamiya' Hull Red (XF9), thinned with 'Tamiya' X20A thinners. The paint should be applied so that it just starts to tint the propeller (not cover the wood laminations).

Is possible, apply 'Imperial' decals to the front of the propeller blades. I used spare 'Wingnut Wings' decals left over from a previous model build.

Seal the propeller using 'Alclad' Light Sheen lacquer (ALC-311).

If desired, lightly sponge brush weathering to the leading edges and tips of the propeller, using 'Tamiya' Weathering Master Set B (Rust).

Using a fine saw, carefully cut away the 'ProperPlane' front and rear propeller boss plates.

Clean up the back of each mounting plate by holding down the front face with a finger and 'drag' the rear faces lightly over a flat sanding surface.

Brush paint the mounting plates with 'Mr. Metal' Stainless Steel (213).

Once dry, buff the surfaces to a metallic finish.

Attach the mounting plates to the propeller hub using CA adhesive.

If desired, apply 'AK Interactive' Kerosene wash (AK 2039) to the mounting plates.



PART 10
FUSELAGE AND
WINGS

PART 10 - FUSELAGE AND WINGS

NOTE: *As a pilot figure will be fitted in the cockpit, it will block from view just about all of the cockpit internal detail. Therefore the cockpit will be a basic assembly without any added detail, such as control cables, pipes and wires etc. As such the cockpit will be assembled then painted as an assembly, rather than painting each part separately then assembling the cockpit.*

Preparation:

Refer to the kit instructions, page 3 for the parts required, including the fuselage halves.

Remove the cockpit parts required, including the fuselage halves, from their kit sprues and remove any residual sprue tags and styrene 'flash' and seams around the parts.

Assembly:

Refer to the kit instruction, page 3 for the assembly instructions.

Assemble the cockpit, except for the pilot's seat harness

NOTE: *My cockpit side frame part C1 had no pre-moulded locations for the seat support frame part C13. If necessary, carry out the following step.*

Insert seat support frame part C13 into its location in the cockpit side frame Part C45.

Hold the seat frame in position and parallel to the cockpit floor.

Mark the position of the ends of the seat frame on the side frame C1.

Remove the seat support frame.

Using the marks as a guide, drill holes of 0.5 mm diameter through the side frame C1.

Cement the seat support frame in position between the two cockpit side frames.

Pilot figure:

Modification:

Before painting the cockpit assembly, Refer to Part 12 (Figures) of this build log for how to modify the pilot figure to fit into the cockpit assembly.

Painting:

Airbrush the cockpit assembly and inside surface of the fuselage halves with a grey primer, such as 'AK Interactive' Grey (AK758) or similar.

Airbrush the cockpit assembly and inside surface of the fuselage halves with 'Tamiya' Buff (XF57) or similar.

NOTE: *Refer to Part 2 (Wood Effects) of this build log for more information.*

Apply the desired wood effect to the cockpit floor part and pilot's seat. For model I used 'DecoArt' Burnt Umber acrylic paint.

Brush paint the cockpit side frames, cross members and seat support frame with 'Tamiya' Grey Green (XF76) or similar.

Brush paint the rudder bar, throttle quadrant, forward panel, fuel tank straps and filler cap and metal fittings on the cockpit floor with 'Mr. Model' Stainless Steel (213) or similar.

Brush paint the fuel tank, hand pump, panel and side frame switches with 'Mr. Colour' Brass (219) or similar.

Brush paint the control column and torque tube with 'Tamiya' Black (X18) or similar.

Brush paint the hand grips on the control column, throttle handle and hand pump handle with 'Tamiya' Hull Red (XF9) or similar.

Apply 'Tamiya' Clear Gloss (X22) onto the instrument face.

Once dry apply the kit supplied decal (16) onto the face of the instrument.

Airbrush the cockpit assembly and inside surface of the fuselage halves with a semi-matte clear coat, such as 'Alclad' Light Sheen (ALC-311), 'Tamiya' Semi-Clear (X35) or similar.

Note: Refer to Part 3 (Weathering) of this build log for more information.

Weather the inside surfaces of the fuselage halves using 'Flory Models' Dark Dirt fine clay wash.

Seal the weather wash by airbrushing with a semi-matte clear coat, such as 'Alclad' Light Sheen (ALC-311), 'Tamiya' Semi-Clear (X35) or similar.

Assembly (continued):

NOTE: The pilot figure and seat harness will be fitted later in the build.

Remove any primer and paint from the mating faces of the left and right fuselage halves.

Remove any primer and paint from the four corner contact points in the left and right fuselage sides where the cockpit assembly will locate and from the corners of the cockpit assembly (both sides).

Secure the cockpit assembly into the right fuselage side by applying cement to the four corners of the cockpit right side frame. The bottom front corner of the right cockpit side frame locates to the rear of the moulded shoulder on the bottom of the fuselage side.

Apply cement to the four corners on the left side frame of the cockpit assembly then locate the left fuselage half against the right half. Make sure the two halves are located together without any obstruction from the cockpit assembly.

Hold the fuselage halves together using elastic bands or similar, making sure all fuselage edges are correctly aligned.

Apply cement along the fuselage join seam, avoiding where possible the areas where the elastic bands or similar are located, to avoid the cement reacting with them.

Once the initial application of cement has fully set, remove the elastic bands etc and apply Cement, where necessary, to the fuselage join seam to complete adhesion.

Sand along the fuselage join seam to remove any excess cement and to blend the two fuselage halves together.

Remove the lower wing (B2), under panel (A9) and decking panel (A8) from their kit sprues and remove any residual sprue tags from their edges.

Test fit lower wing and decking panel into the fuselage and check for any misfitting or gaps etc.

Brush paint the inner surface of the under panel with 'Mr. Colour' Stainless Steel (213) or similar.

NOTE: The decking insert panel (kit part A8) will be fitted after the pilot figure has been finally fitted into the cockpit.

Brush paint the inner surface of the decking panel with 'Tamiya' Buff (XF55).

Cement the under panel into the fuselage and once the cement has set, sand the edges to blend the panel with the fuselage.

Pre-construction - preparation and modifications:

NOTE:

At this stage, certain preparation and modifications need to be made, as follows:

Strengthening the attachment of the lower wing to the fuselage.

Adding the elevator control lever and cable to the underside of the fuselage.

Preparation for adding four fuselage side 'rods'

Adding location points for the struts of the landing gear.

Adding location points for the struts of the tail skid assembly.

Replacing the tail skid struts (optional).

Shortening the tail skid.

Creating elevator cable ports.

Creating rudder cable ports.

Fuselage cabane strut locations.

Aligning the engine main and sides cowl panels.

Adding the fuselage and lower wing rigging points.

Lower wing attachment.

Elevator attachment.

Elevator control horns.

Rudder control horns.

Adding the upper wing rigging points.

Lower wing attachment:

NOTE: *The intended method of attaching the lower wing to the fuselage relies on a flimsy central 'spar' of styrene joining the two lower wings. This is intended to be cemented into its location slot in the underside of the fuselage. However, this only gives edge contact which I considered was not strong enough to support the lower wings. Therefore I added extra support for the lower wings attachment.*

Cut two strips of 0.8 mm thick styrene sheet such that when cemented together, they could be positioned in the fuselage slot between the cockpit sides.

Cement the two strips together, making sure the long edges are aligned.

File or sand the height of the combined strips and with a slight chamfer along the one long edge.

Test locate the strip into the fuselage slot with the chamfered edge facing towards to front of the fuselage.

Locate the lower wing into the slot and onto the support strip.

Check that the 'spar' of the lower wing is aligned with the bottom of the fuselage and the leading edge of the wings are aligned with the bottom edges of the fuselage. Adjust as required to achieve this fit.



Underside elevator control:

NOTE: It appears that the end of a control lever protruded from the underside of the fuselage, below the pilot's control column. A cable was attached to the end of this lever and was routed rearwards and into an opening to the rear of the lever. The exact function of this lever and cable are unclear, but my assumption is that they are part of the elevator control from the control column. The kit does not include this lever arrangement.

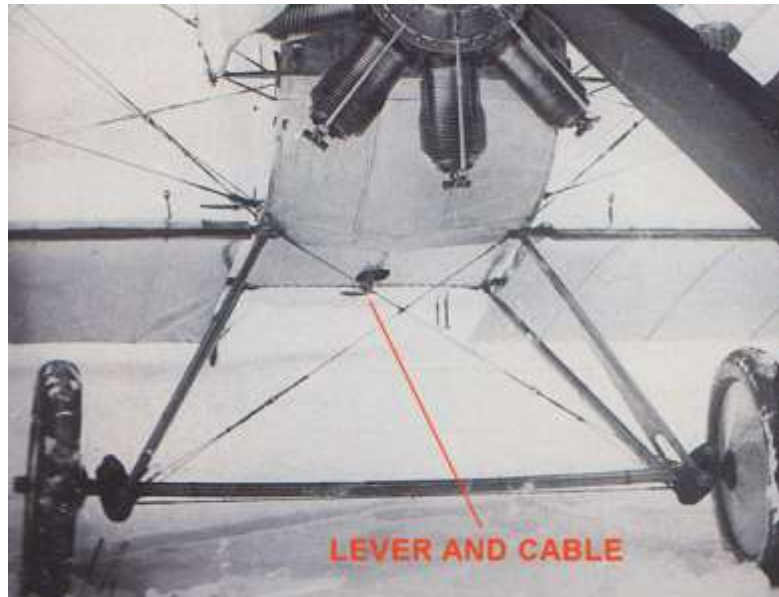

Mark a line across the underside of the fuselage 10 mm back from the rear edge of the lower wing location slot. This will be used later as the guide line for adding the kit supplied photo-etch stitching.

Point mark the fuselage seam join 6 mm forward from the line and also 4 mm rearward from the line.

Using the point marks as a guide, drill a hole of 1.2 mm diameter through the underside of the fuselage. To avoid damaging the cockpit parts, make sure the drill does not penetrate too far into the cockpit area.

Drill each side of the two holes to create slots of 4mm length.

NOTE: The control lever and cable will be added later in this build.

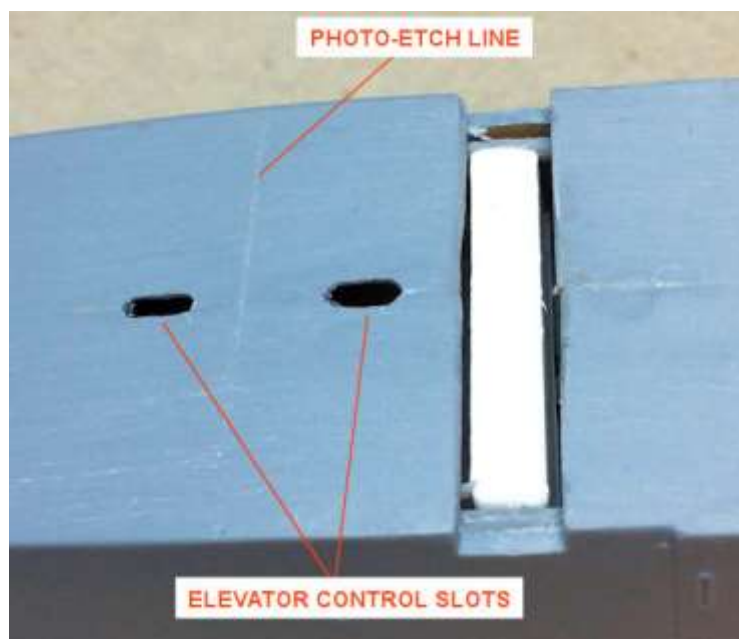

Fuselage transportation posts:

NOTE: Two short 'posts' were fitted into circular panels on both sides of the fuselage, just forward from the cockpit. These posts possibly used to secure the dismantled wings to the fuselage for transportation, as can be seen in the following photograph. The kit has these circular panel pre-moulded into the fuselage sides. Posts were also fitted at the wing root of the lower wings.

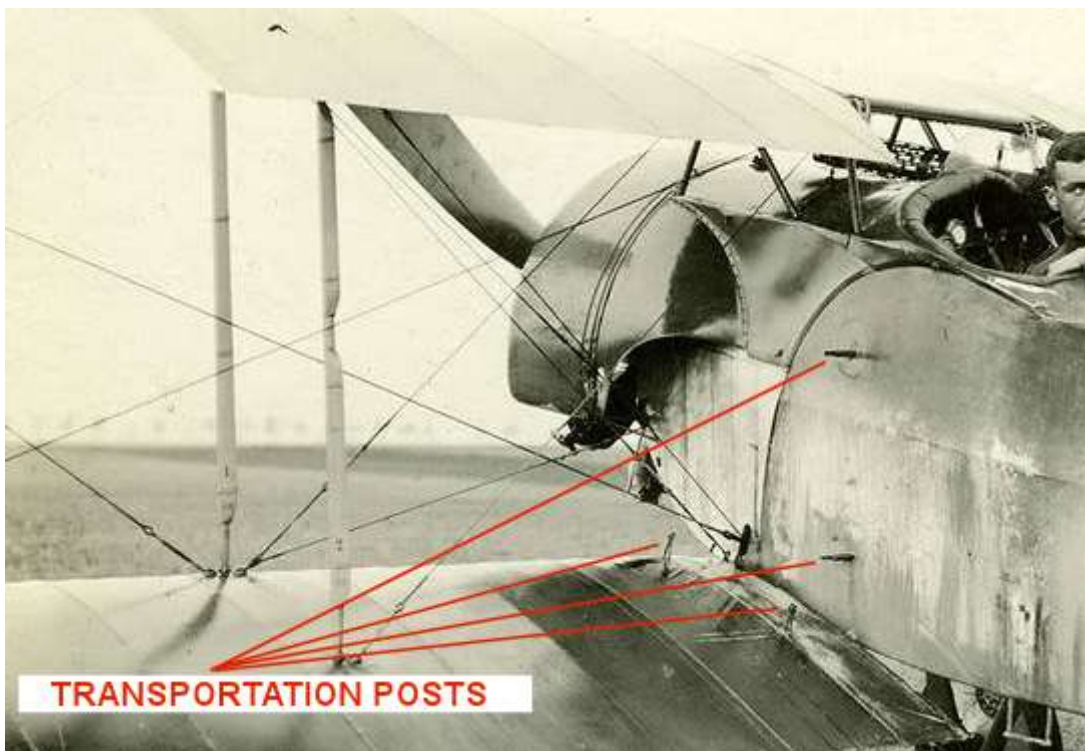
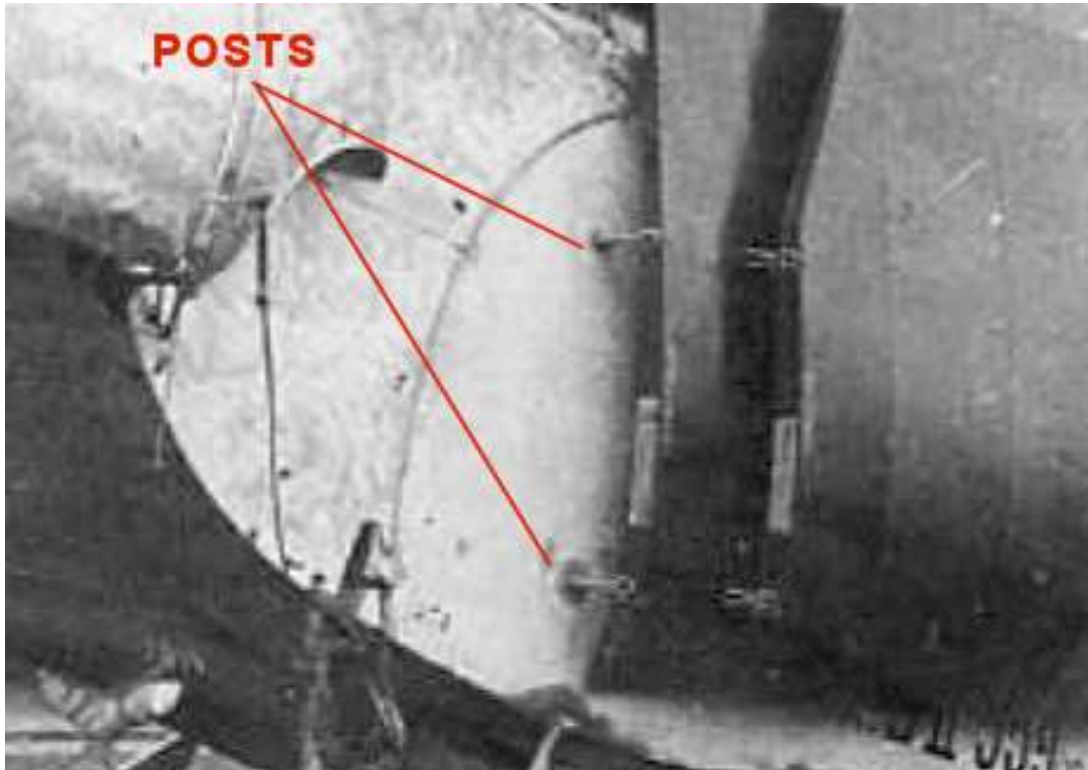

Drill a hole of 0.4 mm diameter through the centre pre-mould rings in the four pre-moulded discs on the sides of the fuselage. These will be for adding the 'rods' later in this build.

Landing gear strut locations:

NOTE: *The landing gear struts and the underside of the fuselage have no locating points and are intended to be just 'butt' glued to each other. This does not provide a strong enough method of attaching the landing gear. Therefore the landing gear struts will be pinned and the fuselage drilled with location holes.*

Remove the two landing gear struts and the axle from their kit sprues. Remove any residual sprue tags and also the small 'locating stub' on the top of the landing gear rear struts.

Point mark the centres on the top of the landing gear front and rear struts.

Using the point marks as a guide, drill a hole of 0.5 mm diameter into each of the struts to a depth of at least 5 mm. Make sure the drill is parallel to the strut when drilling so as to avoid the drill breaking through the side of the strut.

Cut four lengths of 0.4 mm brass rod such as that from 'Albion Alloy's or similar.

Secure the rods into the pre-drilled holes in the struts, using thin CA adhesive.

Point mark four location hole positions on the underside of the fuselage (two on each side). The positions of the four holes are shown on the **following photograph**.

Using a drill of 0.5 mm diameter, drill the two rear holes vertically through the underside of the fuselage. To avoid damaging the cockpit parts, make sure the drill does not penetrate too far into the cockpit area.

Using a drill of 0.5 mm diameter, drill the two forward holes vertically through the underside of the fuselage. To avoid damaging the cockpit parts, make sure the drill does not penetrate too far into the cockpit area.

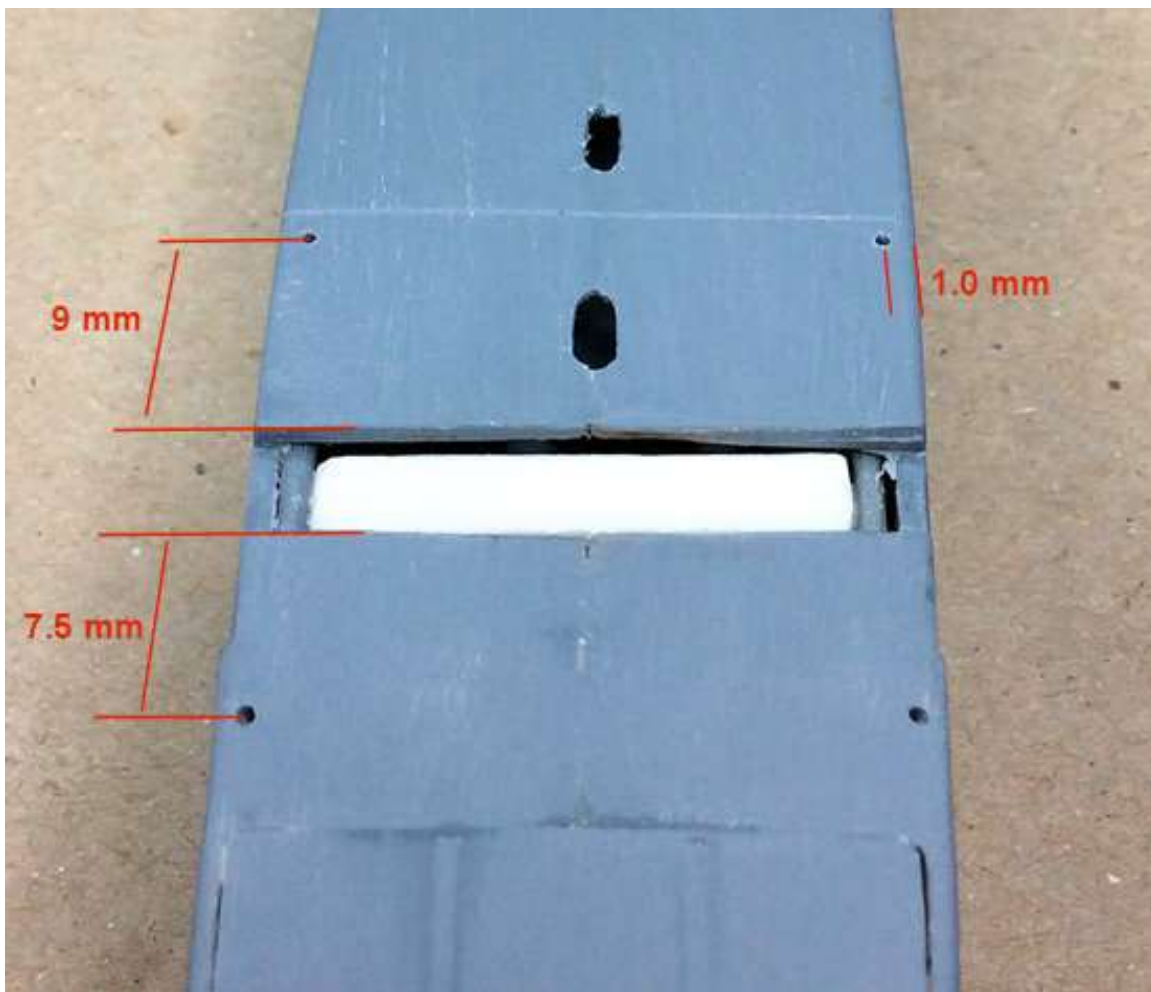

Locate the two landing gear struts into their pre-drilled holes. Make sure the struts are located on their correct side of the fuselage (chamfer on the top of the forward struts angles struts out at the bottom).

Check the location of the axle onto the landing gear struts and note how far in or out the struts need to be angled so that the axle strut locating lugs align correctly to the landing gear struts.

Remove the axle and struts and carefully bend the landing gear locating rods to the angles required such that when the struts are re-fitted, the struts are equally angled out (when viewed from the front) and the axle locating lugs align with the struts.

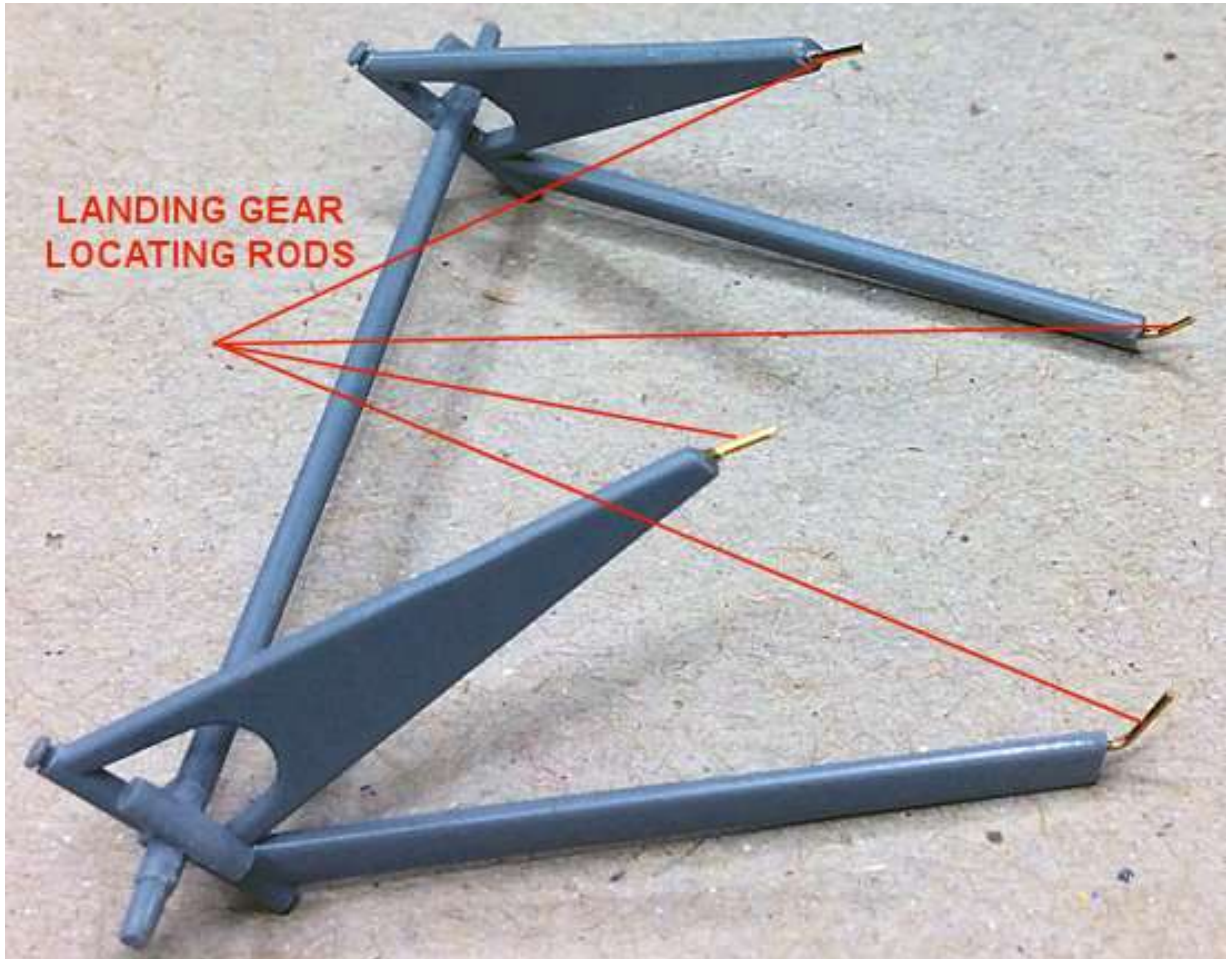

Locate the axle onto the landing gear struts and cement in position.

Once the cement has set, carefully remove the landing gear assembly.



Tail skid strut locations:

NOTE: *The two struts for the tail skid need to be located more positively into the bottom, rear of the fuselage.*

Refer to the following photograph for the positions of the strut location holes.

Drill holes into, but not through, the bottom, rear of the fuselage using a 1.2 mm diameter drill. The holes should be drilled at the angles such that when the struts are located, the tops of the struts touch.

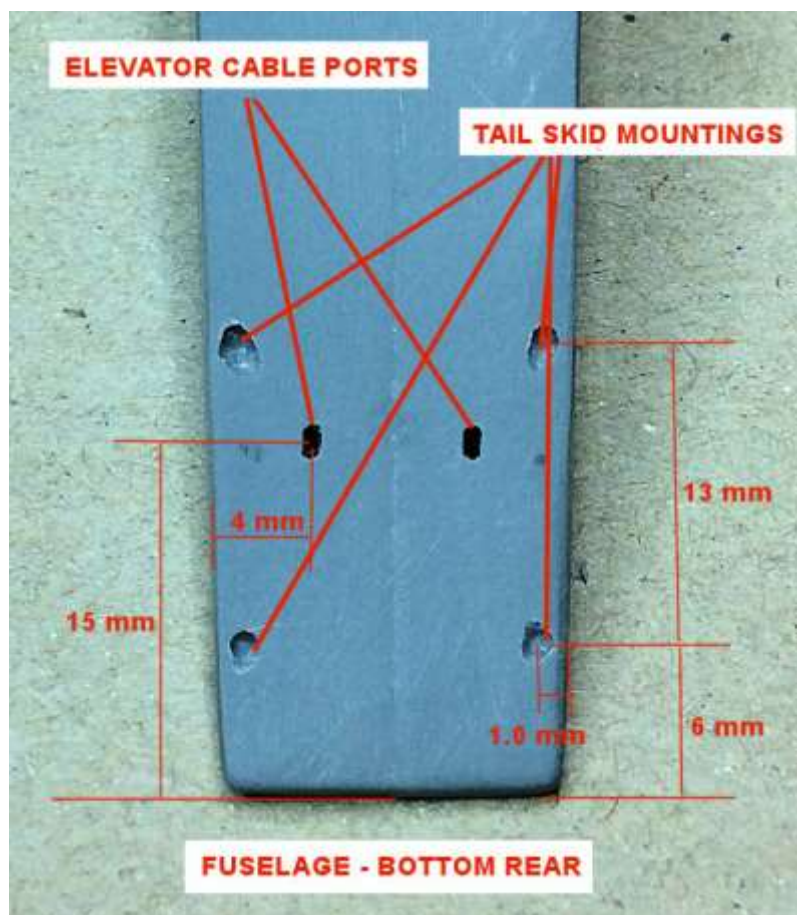

Tail skid strut - replacement:

NOTE: *The two struts for the tail skid are not very strong, so I chose to replace them with brass tube. This is my preference and is not a necessary modification for the model.*

Cut two lengths of 0.9 mm diameter brass tube, such as 'Albion Alloy's MBT09 or similar, to match the lengths of each leg of a kit supplied tail skid strut.

File a chamfer on one end of each tube such that when positioned against each other, they match the 'V' angle of the kit strut.

Cut a length of 0.5 mm diameter brass rod from 'Albion Alloy's or similar.

Bend the rod to match the kit supplied strut.

Slide the tubes onto the rod with the chamfered ends up to the 'V' of the rod.

Using solder paste, solder the tubes to the rod.

Drill a hole of 0.5 mm diameter vertically into the struts locating recesses in the rear, underside of the fuselage.

Cut the ends of the protruding rods at the tube ends to 4 mm protruding.

Bend the protruding rods such that when inserted into the pre-drilled holes in the fuselage, the ends of the tube locate into their recesses and the tip of the 'V' on the strut is central over the fuselage underside (when viewed from above).

Repeat to create the opposite strut.

Test fit the two created struts and make sure they fully locate and the tips of the 'V' are in contact with each other.

Hold the struts in position in the fuselage and using solder paste, solder the tips of the 'V' together.

Remove the strut assembly from the fuselage.

Cut a length of 0.4 mm diameter brass rod from 'Albion Alloy's or similar.

Bend the rod around the 'V' joint of the struts with one end of the rod is located at the front of the struts and angle backwards.

Using solder paste, solder the bent rod to the 'V' joint of the strut assembly.

Cut the 0.4 mm diameter rod to leave approximately 3 mm protruding.

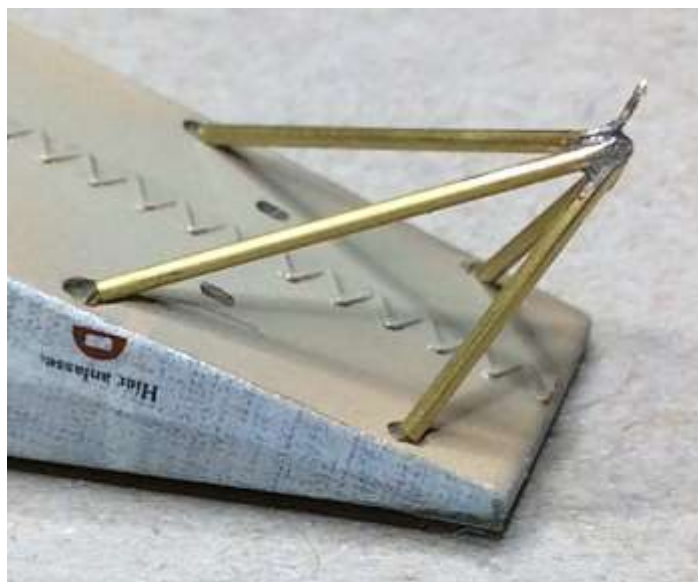

Tail skid - modification:

NOTE: *The kit supplied tail skid seems to be too long, when compared to drawings and colour profiles, such as that shown below. The length of the tail skid from its location on the strut assembly needs to be shortened so that the 'shoe' of the skid is just to the rear of the struts.*



Cut the 'shoe' from the tail skid.

Cut the remaining skid off at the mounting bracket.

Drill a hole of 0.4 mm diameter into the cut edge of both the 'shoe' and the tail skid.

Cut a short length of 0.4 mm diameter brass rod from 'Albion Alloy's or similar.

Secure the cut rod into the shoe' using thin CA adhesive.

Locate the 'shoe' rod into the pre-drilled hole in the tail skid, making sure the 'shoe' is correctly positioned (bottom of 'shoe' facing away from the struts).

Temporarily locate the tail skid strut assembly into its pre-drilled holes in the rear, underside of the fuselage.

Locate the tail skid onto its mounting rod on the struts and check that the mounting rod is not obstructed by the 'shoe' locating rod. If necessary cut the end of the 'shoe' rod until it fully locates.

Secure the 'shoe' rod into the tail skid, using thin CA adhesive.

Remove the tail skid from its support struts.

Remove the strut assembly from the fuselage

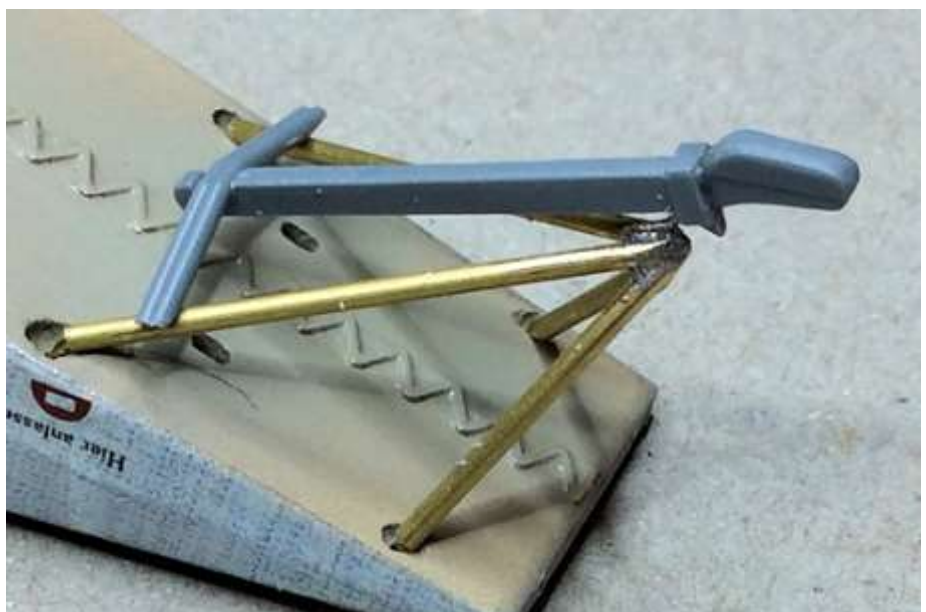

Elevator cable ports - bottom:

NOTE: *The two ports for the elevator control cables need to be drilled through the bottom of the fuselage.*

Refer to the above photograph for the positions of the elevator cable ports.

Drill holes through the bottom, rear of the fuselage using a 0.6 mm diameter drill. Drill two inline holes the join them to for a slot.

Elevator cable ports - top:

NOTE: *The two ports for the elevator control cables need to be drilled through the top of the fuselage.*

Refer to the following photograph for the positions of the elevator cable ports.

Drill holes through the top, rear of the fuselage using a 0.6 mm diameter drill. Drill two inline holes the join them to for a slot.

Rudder cable ports - top:

NOTE: *The two ports for the rudder control cables need to be drilled through the top of the fuselage.*

Refer to the following photograph for the positions of the elevator cable ports.

Drill holes through the top, rear of the fuselage using a 0.6 mm diameter drill. Drill two inline holes the join them to for a slot.

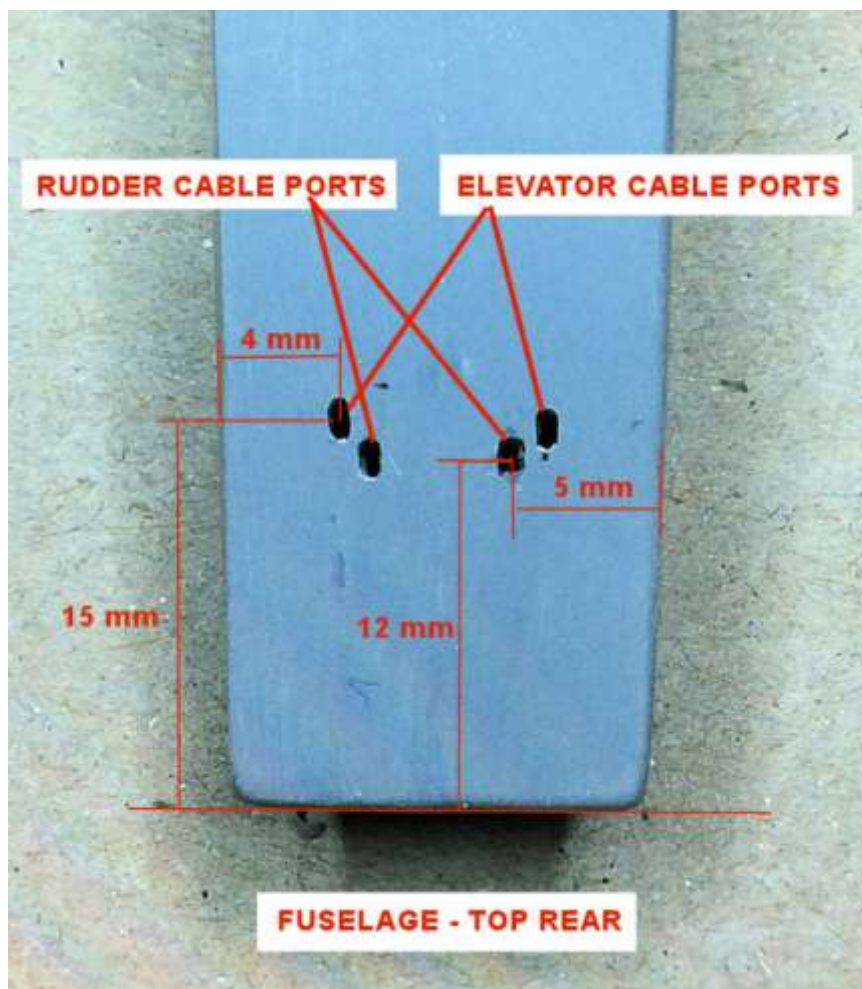

Cabane strut locations:

NOTE: *The two fuselage cabane struts and the wing warp control pulley support at the forward, top of the fuselage locate in shallow recesses in the fuselage. These recesses are not Moulded precise enough and do not provide a positive contact for the struts.*

Using an appropriate modelers chisel, carefully 'square off' the six recesses to give a more positive location for the ends of the struts.

Alignment of engine cowl panels:

NOTES:

The kit instructions, on page 4, shows a diagram for modifying the fuselage forward side cowl panels. This involves cutting away the bottoms of the panels as well as packing the out from the fuselage sides. This is because when fitted, the side panels will not align with the outer profile of the engine cowl. I can only assume this is an afterthought by the kit manufacturer, but why the kits parts are not moulded to correctly align is another question?

The engine can be located up and into its locating hole in the front of the fuselage, even with the main cowl fitted. During the following steps, do not squash together the sides of the main engine cowl, as this can cause stress lines.

I chose to ignore the kit instructions for modifying the cowls to fit correctly and instead used the procedure that follows.

Remove any sprue tags or flash from the main engine cowl (A10) and the two side cowl panels (A5 and A6).

Scrape or sand away the inside edges of the main cowl and the two cowl side panels to reduce their thickness to a more realistic scale.

Using a horizontal grid marking line on a cutting mat, align the bottom edges of the main engine cowl on a horizontal line.

Keeping the cowl on that line, position it such that the top, centre of the cowl is on a vertical line by making sure the distances of the cowl bottom edges from their nearest vertical lines are equal.

Using the vertical line as a guide, mark the centre line of the main cowl on its rear edge.

NOTE: *During the following steps, do not squash together the sides of the main engine cowl, as this it needs to be 'relaxed' in its moulded shape when being cemented in position.*

Position the main cowl onto the front of the fuselage and align the centre mark with the fuselage seam join. Make sure the cowl align to the curve on the fuselage.

Cement the main cowl onto the fuselage.

Cut away 1.5 mm from the bottom tip of the two side cowl panels.

Locate the right side cowl panel in position against the fuselage and the rear edge of the fitted main cowl.

Check that the side panel aligns fully with the fuselage and main cowl. If necessary scrape or sand the edges to achieve a good fit and alignment.

Repeat the procedure on the left side cowl panel.

Cement the two side cowl panels in position and correctly aligned.

Insert temporary packing in the gap between the side of the fuselage and the bottom tip of the side cowl panels. This will prevent the panel flexing when being drilled.

Drill a hole of 0.5 mm diameter through the bottom of each side cowl panel, approximately 4 mm up from the tip and 1.5 mm back from the panel to main cowl joint.

Remove the temporary packing and using the drilled hole as a guide, drill into the fuselage.

Cut two lengths of 0.5 mm diameter rod from such as 'Albion Alloy's or similar.

Insert the rods through the pre-drilled hole in the side cowl panel and into the fuselage hole.

Make sure the outer end of each rod is just above the surface of the side cowl panels.

Secure the rods to the side cowl panels and the fuselage, using thin CA adhesive.

If necessary, use modelling putty to fill any gaps around the panels.

If necessary, carefully sand the various cemented joints to blend them with the surrounding areas.



Rigging points:

NOTE: At this stage of the build, it's best to add the various rigging points to the fuselage. Refer to Part 6 (Rigging) of this build log for more information.

Refer to the following photograph.

The rigging points required for the fuselage are:

Wing warping wires (x4) to the top of the rear interplane struts.

Flying wires (x4) to the top of the inboard, forward interplane strut.

Drift wire (x2) to the bottom of the inboard, forward interplane strut.

Landing gear bracing wires (x2) to axle.

Forward cabane strut bracing wires (x2).

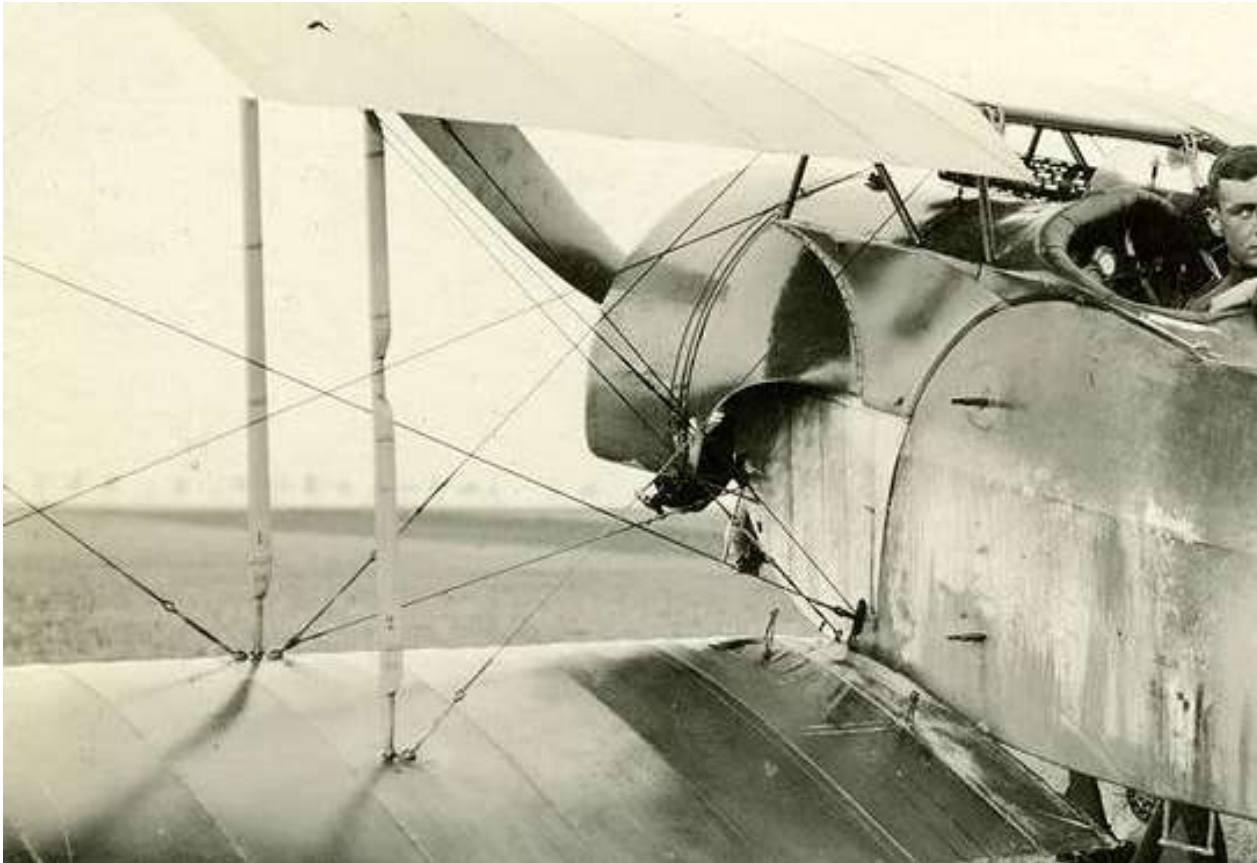

Using the pre-moulded outlet in the fuselage for the wing warp cables, drill holes of 0.4 mm diameter through both sides of the fuselage to create a slot. The drilled holes can be merged using a fine scribe.

Drill holes of 0.3 mm diameter through both sides of the fuselage:

Flying wire - through the fuselage sides, just forward and to the bottom of the slot for the wing warp cables.

Flying wire - through the lower part of the cowl side panels.

Drift wire - through the fuselage sides, just under the bottom tip of the cowl side panels.

Landing gear bracing - through the underside of the fuselage, just inboard from the forward landing gear strut locations.

Forward cabane bracing wires - through the top of the fuselage, each side of the fuselage seam joint (see following photograph).

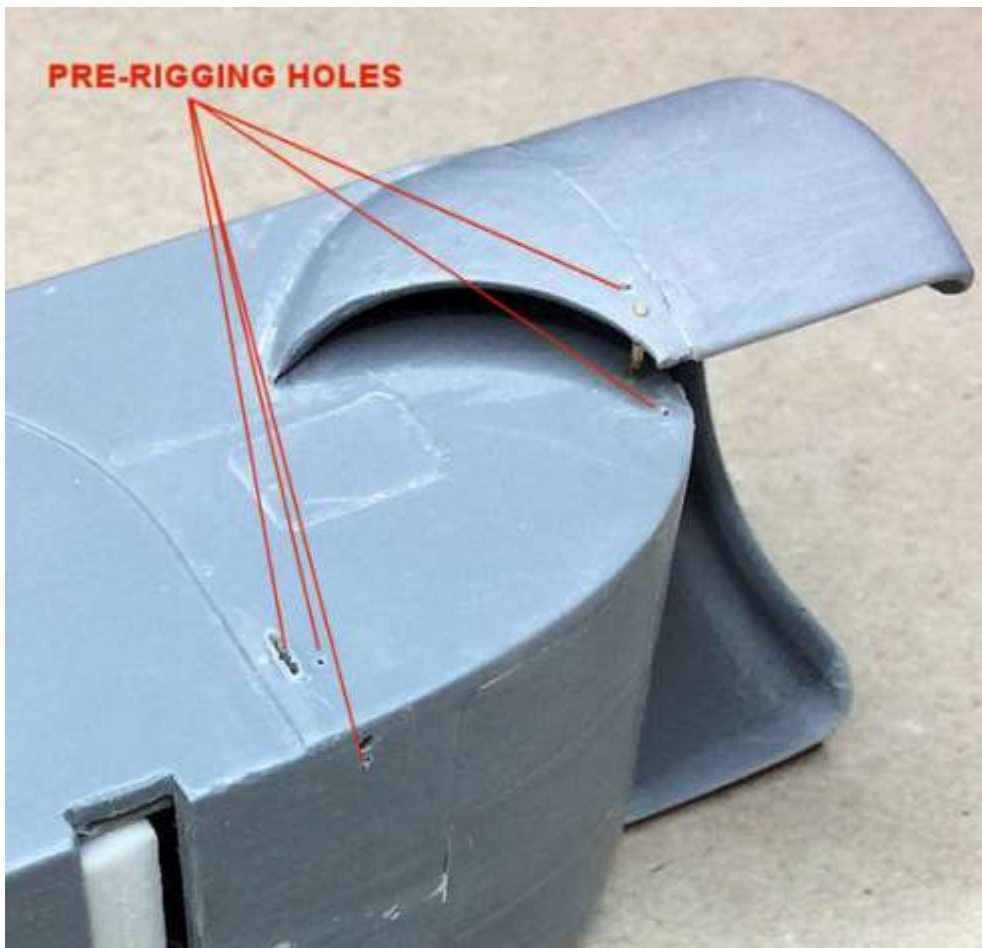
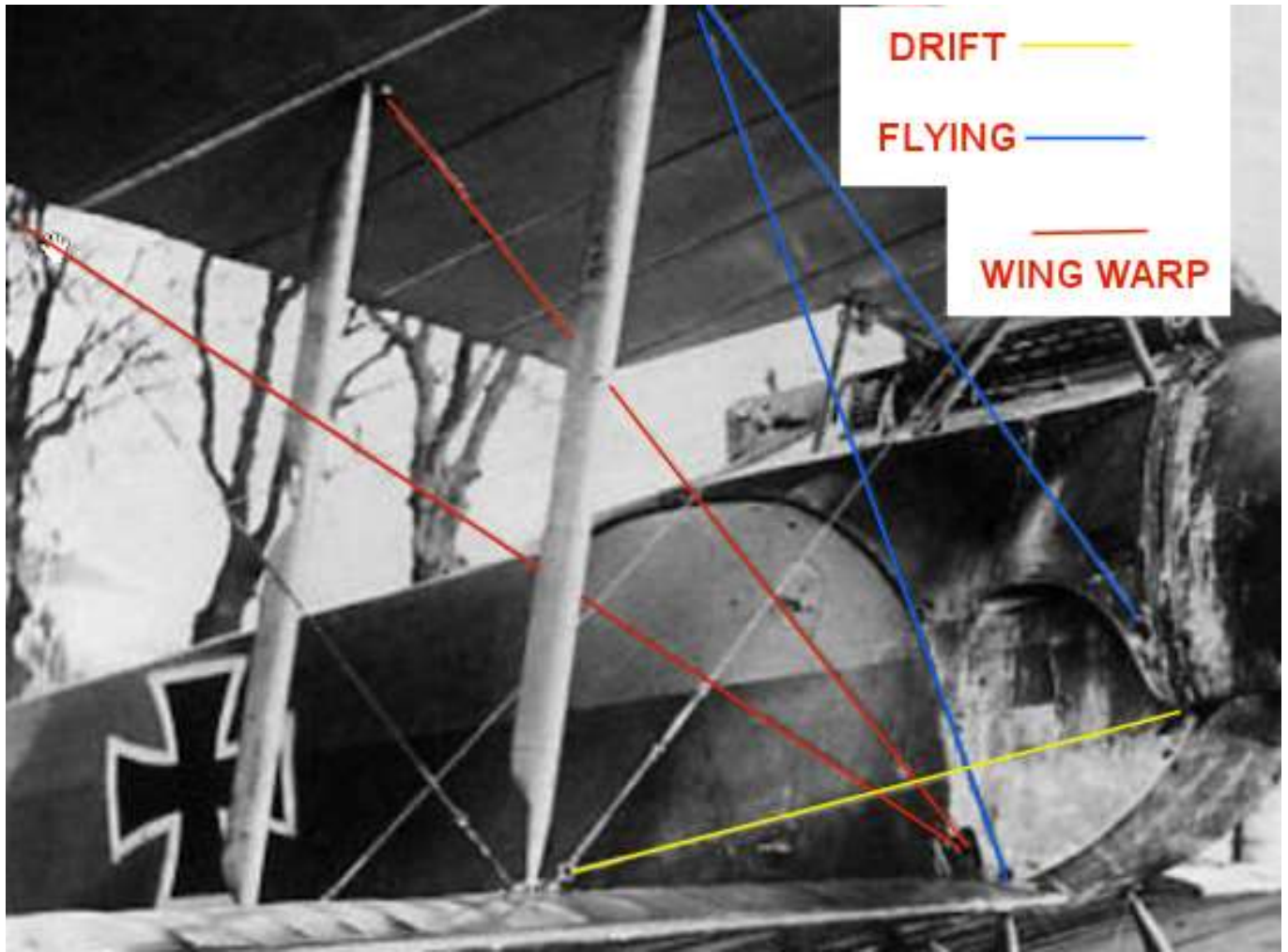

Remove 1 mm from the right side of the machine gun slot in the forward decking of the fuselage. This clearance is for when the 'GasPatch' machine gun is fitted.

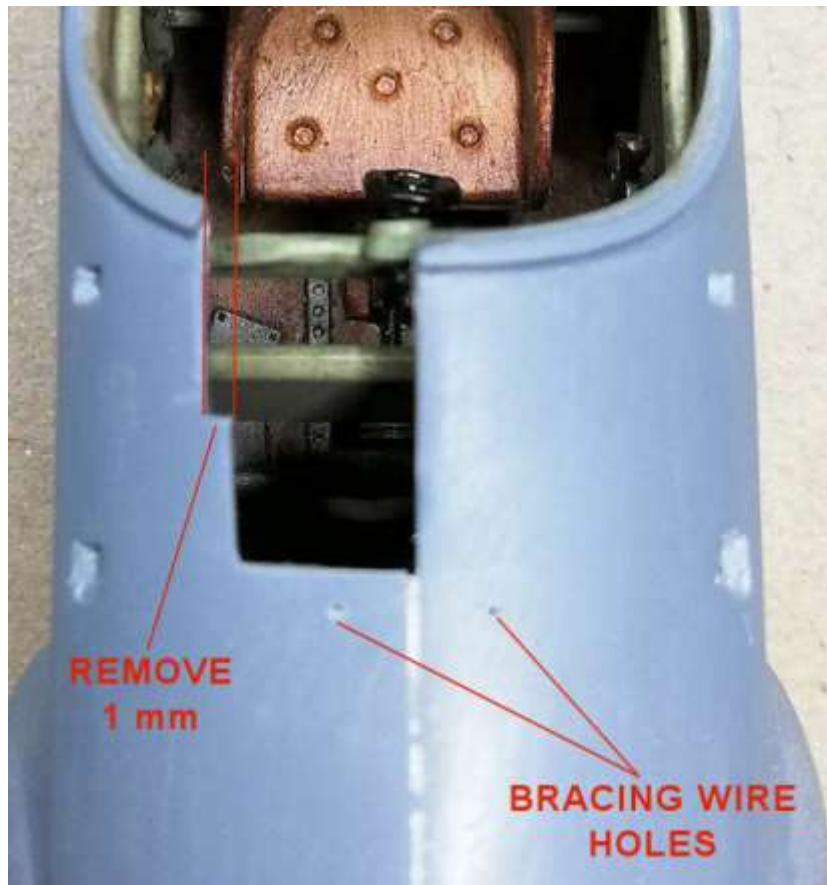

Assembly (continued):

Temporarily locate the machine gun into its slot and position the photo-etch muzzle blast plate onto the main engine cowl.

Note the position on the main engine cowl of the blast plate, which should be centrally aligned to the muzzle of the machine gun.

Remove the machine gun and secure the blast plate on the engine main cowl using thin CA adhesive.

Lower wing preparation:

Remove the lower wing from its kit sprue and remove any residual sprue tags of styrene flash around the edges.

Drill two holes into, but not through, the upper surface of the lower wings. The holes should be drilled on the first wing rib tap from the edge of the wing roots and 14 mm then 21 mm from the trailing edges of the wings. These holes will be used for fitting the transportation posts later in the build.

Lower wing - attachment:

NOTE: *The lower wing needs to be fitted to the fuselage then filled as required and sanded flush with the underside of the fuselage.*

Test fit the lower wing 'spar' into its locating slot on the underside of the fuselage. When located the wing should be horizontal when viewed from the front with the leading edges aligned to the bottom edge of the fuselage.

Cement the lower wing into the fuselage.

Drill two holes of 0.8 mm diameter through each side of the 'spar' of the lower wing and into the styrene packing block previously attached to the underside of the cockpit assembly.

Cut two lengths of 0.8 mm diameter rod, such as that from 'Albion Alloy's' or similar.

Secure the two rods into the pre-drilled holes in the lower wing 'spar', using CA adhesive.

File across the 'spar' of the lower wing to remove the exposed ends of the reinforcing rods.

Fill any gaps around the lower wing joint with CA adhesive.

Fill the lower wing joint area with either a modelling putty.

Once the modelling filler has set, sand the joint area on the underside of the fuselage to blend it with the surrounding fuselage surface.



Secure the two photo-etch 'stitch' rows (PE18 and 21) onto the underside of the fuselage.

Elevator attachment:

NOTE: *The elevator is intended to be 'butt' glued to the rear edge of the fuselage, which does not provide good attachment. Therefore I chose to pin the elevator to the fuselage to give extra support.*

Drill a hole (front to rear) of 0.3 mm diameter through the two 'bands' on the elevator cross bar. If the elevator is to be fitted slightly down, the holes should be drilled at the required angle.

Cut two lengths of 0.3 mm diameter brass rod, such as 'Albion Alloy's' or similar.

Secure the rods into the pre-drilled holes using thin CA adhesive. The ends of the rods should be flush with the rear of the elevator cross bar.

Position the elevator to the rear edge of the fuselage and mark the position of the two rods.

Using the two marks as guides, drill two holes of 0.4 mm diameter into the rear edge of the fuselage.

Test locate the elevator into the rear edge of the fuselage, making sure the cross bar locates fully against the fuselage.

Remove the elevator.

Elevator control horns:

NOTE: *The photo-etch control horns for the elevator (PP4B) are intended to be 'butt' glued onto the elevator cross bar. This does not create a strong joint for when rigging is subsequently fitted. Therefore I chose to cut grooves into the cross bar to more fully locate the control horns.*

Using a sharp and narrow modellers chisel or similar, make a slight groove depression into the upper and lower sides of the 'bands' on the elevator cross bar. The grooves on each side of the cross bar should be directly opposite each other.

Remove the four photo-etch control horns (PP4B) from their sheet and cut or file away any residual tags on their edges.

Using a slow, thicker CA adhesive, secure the four control horns into the created grooves, making sure the control horns are vertical when viewed from the front or rear of the elevator.

If necessary, apply more CA adhesive around the base of the control horns to strengthen the joint.

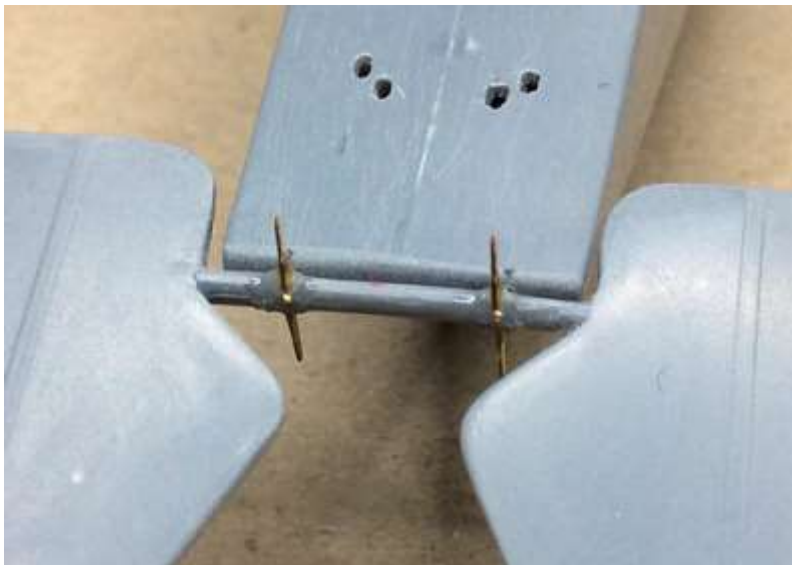

Rudder control horns:

NOTE: *The photo-etch control horns for the rudder (PP4A) are intended to be 'butt' glued onto the sides of the rudder. This does not create a strong joint for when rigging is subsequently fitted. Therefore I chose to cut grooves into the sides of the rudder to more fully locate the control horns.*

Using a sharp and narrow modellers chisel or similar, make a slight groove depression into the both sides of the rudder at the top of the rudder post. The grooves should be directly opposite each other and be from the front to rear of the rudder.

Remove the two photo-etch control horns (PP4A) from their sheet and cut or file away any residual tags on their edges.

Using a slow, thicker CA adhesive, secure the two control horns into the created grooves, making sure the control horns are horizontal when viewed from the front or rear of the rudder.

If necessary, apply more CA adhesive around the base of the control horns to strengthen the joint.



Upper wing preparation:

Remove the upper wing from its kit sprue and remove any residual sprue tags of styrene flash around the edges.

PART 11

CONSTRUCTION

PART 11 - CONSTRUCTION

NOTE: *White primer is used to both provide the fuselage and rudder base colour and to provide the base coat for when the 'Aviatic' streaked camouflage decals and Clear Doped Linen (CDL colour is applied.*

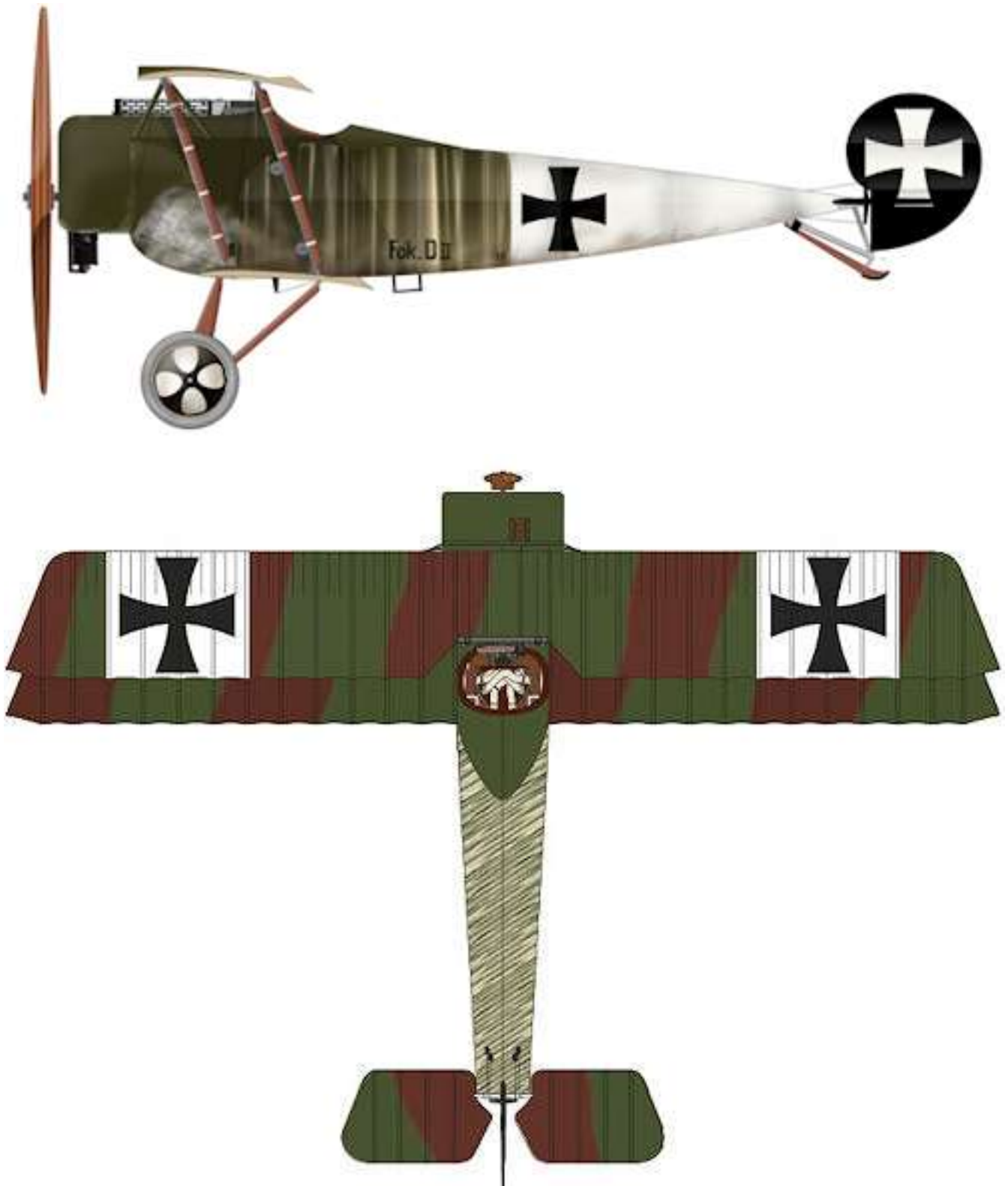

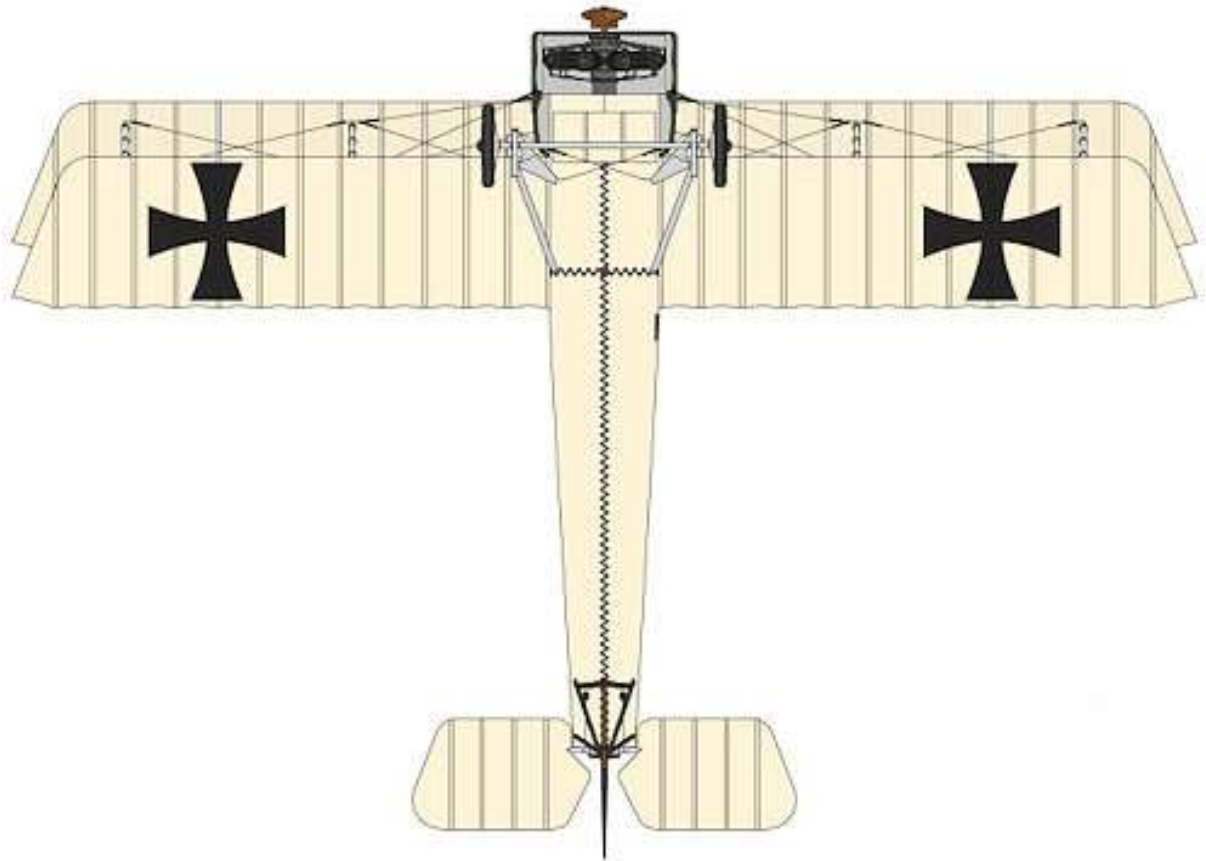

Masking - general:

Mask off the cockpit area, hole for the engine mounting and the two underside slots for the elevator control lever and cable.

Clear Doped Linen (CDL):

Priming:

Airbrush the following with a white primer, such as 'AK Interactive' White (AK-759) or similar.

Undersides of the upper and lower wings.

Underside of the elevators.

Underside of the fuselage.

Sides and top of the fuselage (not including forward fuselage, rear decking panel and engine cowls.

Rudder.

Masking:

Refer to the previous illustrations and mask off the white area on the fuselage sides, the fuselage forward panels and engine cowls, the top rear decking panel and the wing root area on the upper surface of the lower wing.

CDL areas:

Airbrush 'Tamiya' Buff (XF57) or similar over the **exposed** areas on the fuselage top and sides, underside of the elevators and undersides of the upper and lower wings and fuselage.

Masking:

Remove the masking.

Masking for pre-shading:

Cut masking tape strips of 1 mm width and mask over the wing ribs tapes on the undersides of the upper and lower wings and the elevators.

Cut masking tape strips of 1 mm width and mask the top, sides and bottom of the exposed areas on the fuselage, to represent the fuselage internal frames and both sides of the rudder.

Cut masking tape strips of 2.5 mm width and mask across the undersides of the upper and lower wings to represent the front and rear wing spars.

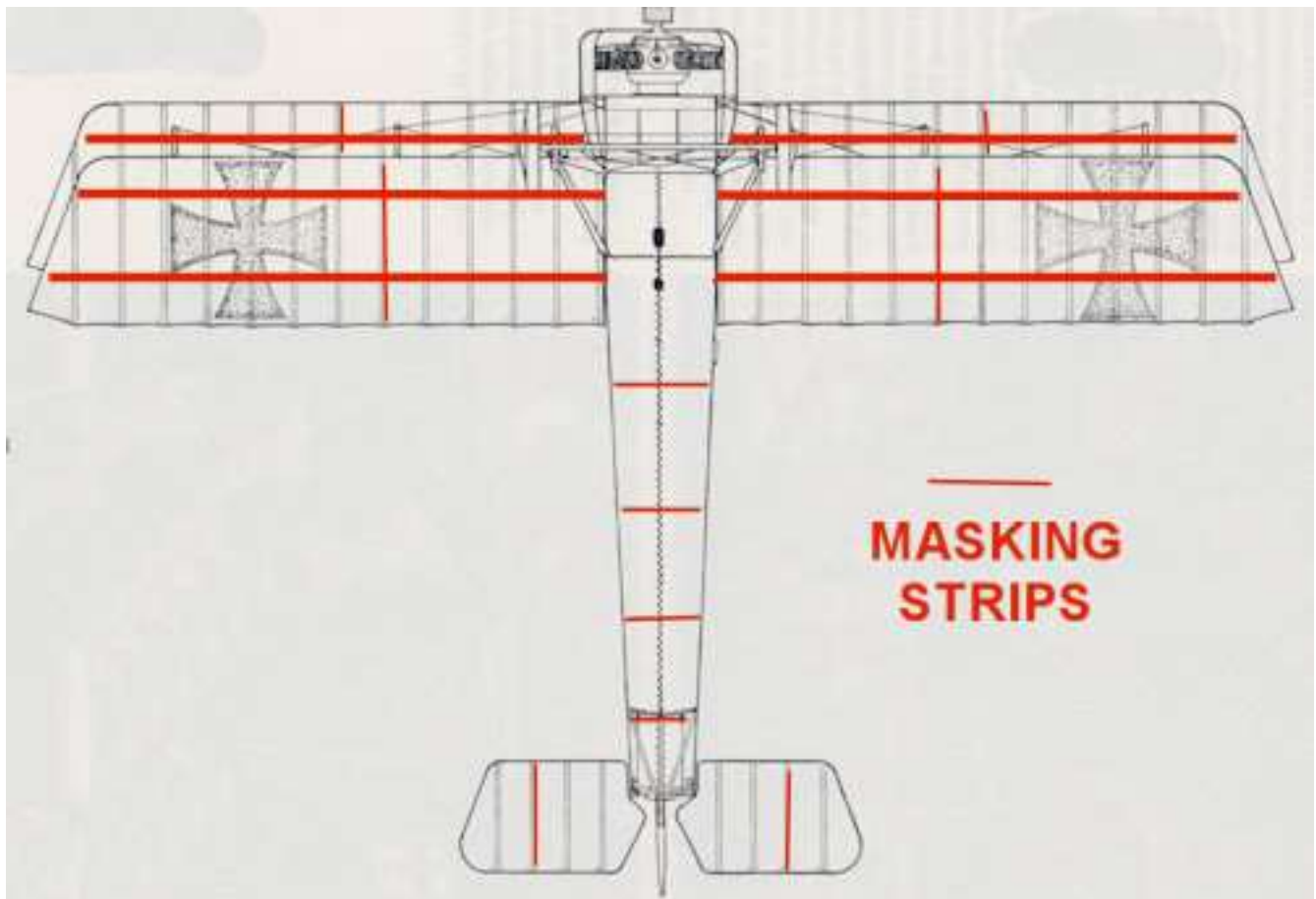
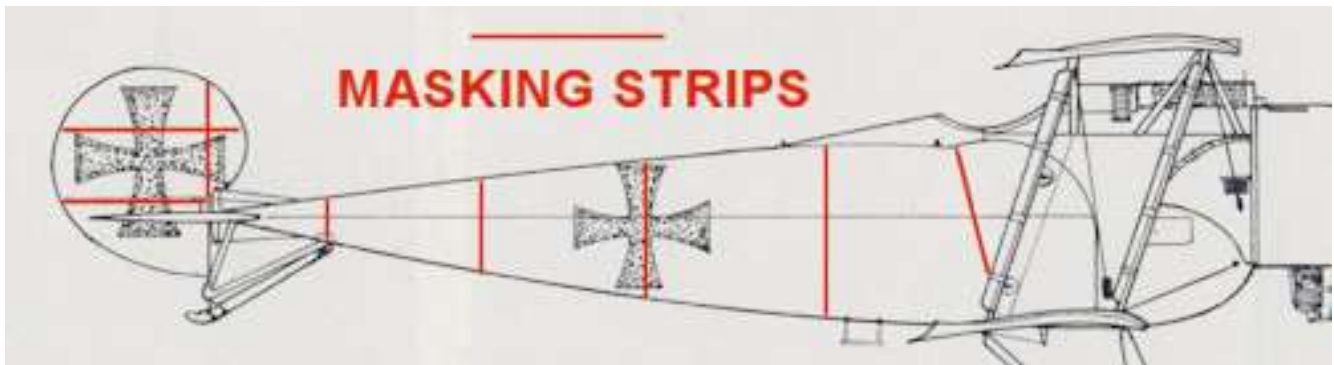

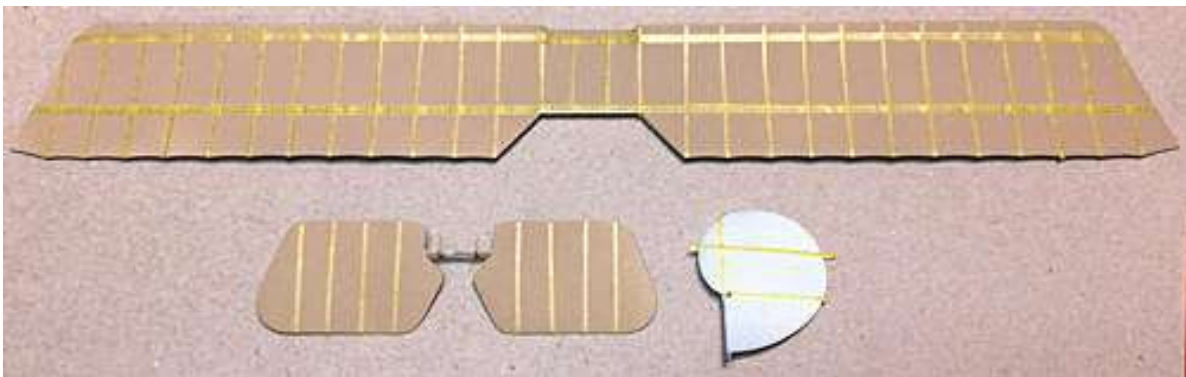
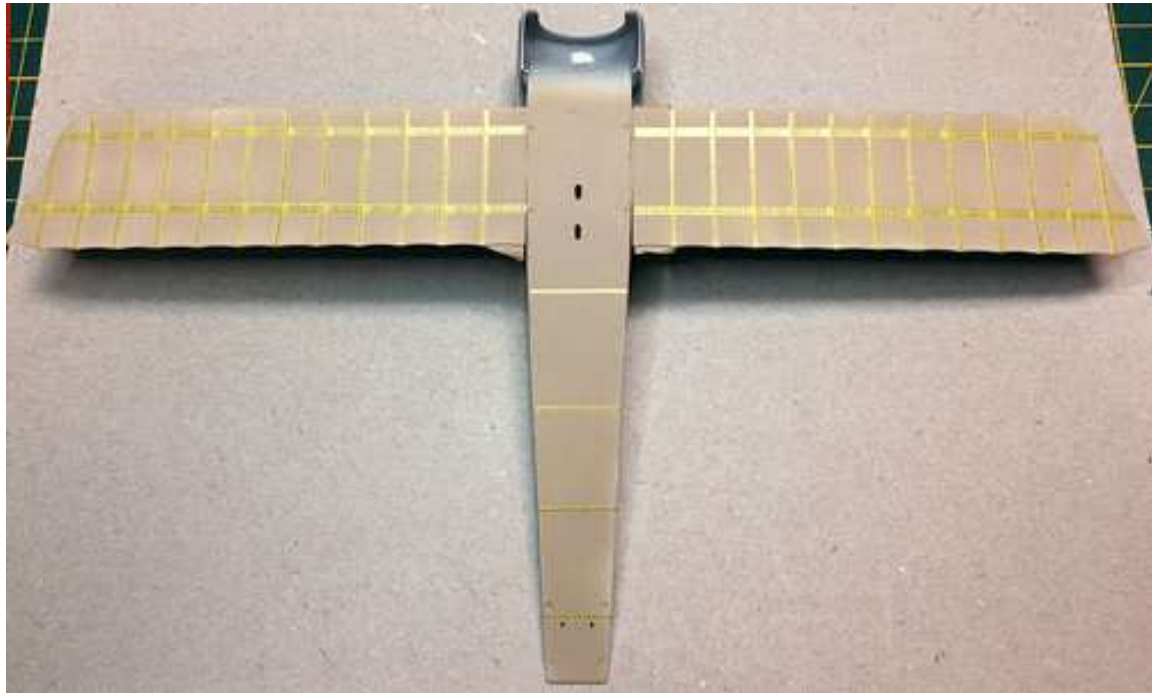

Pre-shading:

Airbrush **light coats** of 'Tamiya' Smoke (X19) along the applied the masking strips:

On the underside of the upper and lower wings.

Along the lower wing roots and the trailing edges of the upper and lower wings.

Along the bottom edges of the fuselage.

Around the fuselage.

Remove all masking strips.

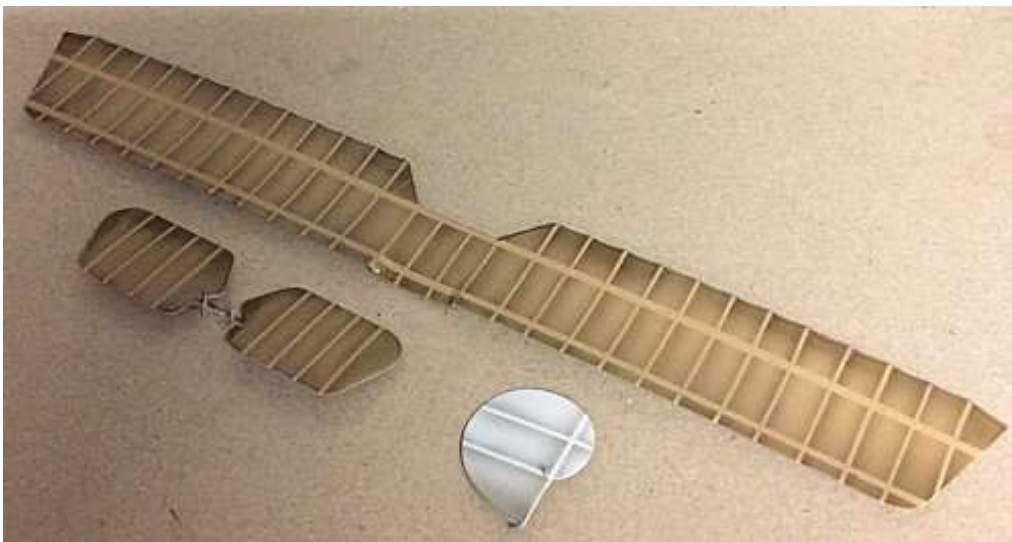

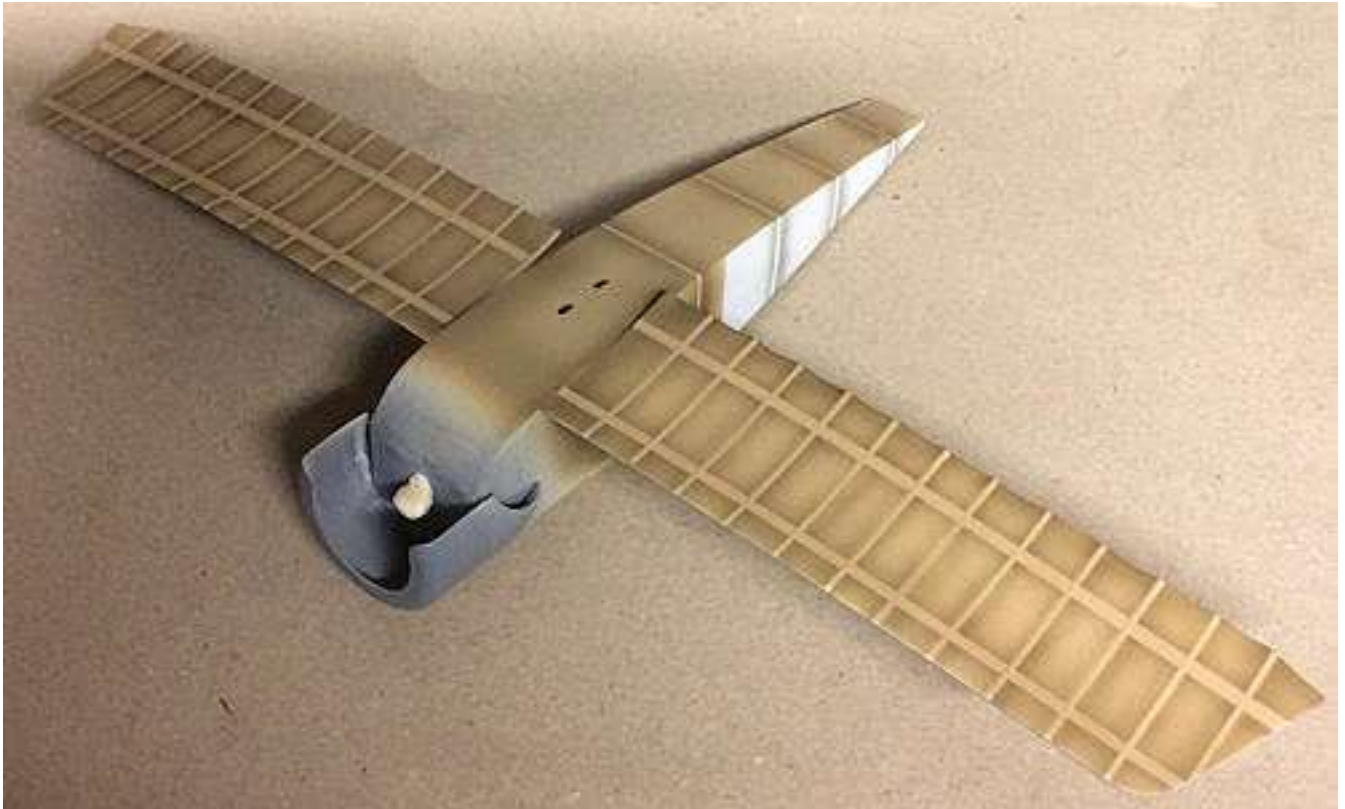

Over spraying:

NOTE: *When over spraying the applied pre-shading, the intention is to fade the pre-shading and blend it into the base colours. It's best to apply light coats and to wait between coats as the pre-shading will tend to show more as the over sprayed coat dries. Airbrushing too much in one go may cover the pre-shading and leave a blank colour, which is not the intention.*

CDL areas:

Refer to the previous illustrations and mask off the white area on the fuselage sides, the fuselage forward panels and engine cowls, the top rear decking panel and the wing root area on the upper surface of the lower wing.

Airbrush **light misting coats** of 'Tamiya' Deck Tan (XF55) or similar over the exposed areas on the fuselage top and sides, underside of the elevators and undersides of the upper and lower wings and fuselage.

Remove all masking.



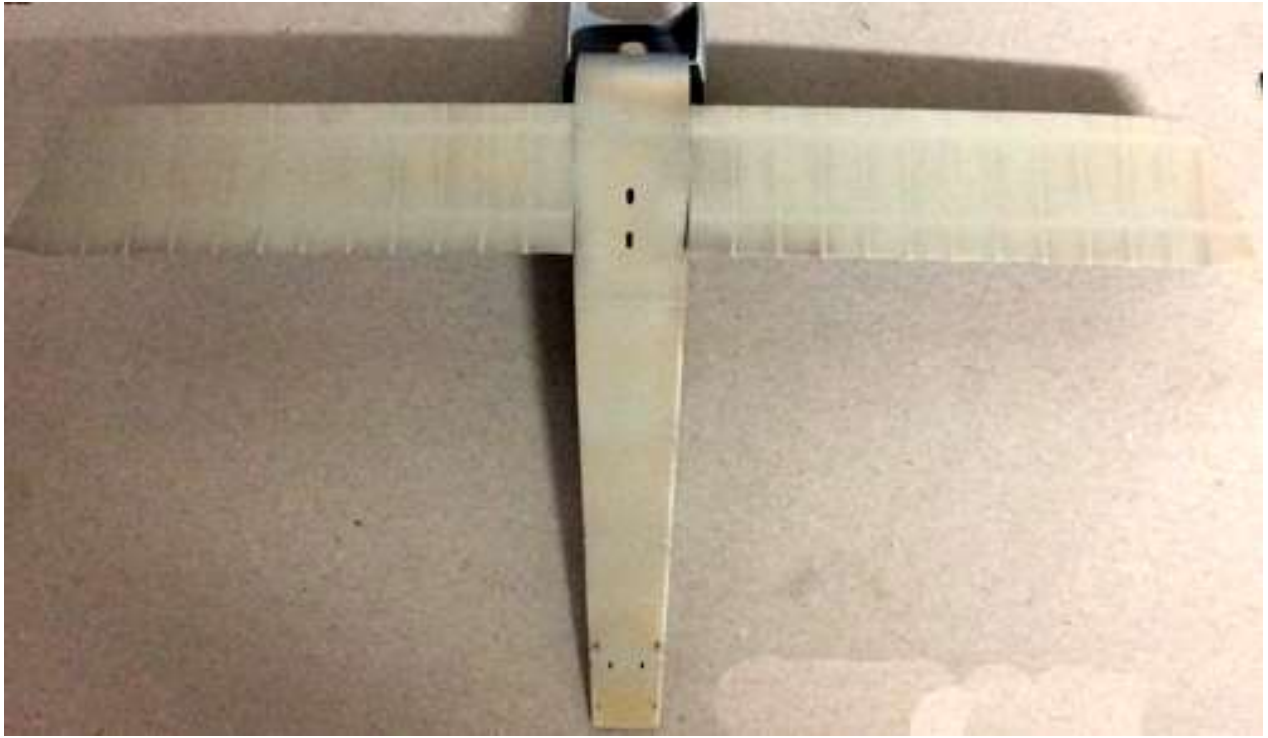

White areas:

Refer to the previous illustrations and mask off all areas **except** for the white fuselage sides and the rudder.

Airbrush **light misting coats** of the white primer previously used, such as 'AK Interactive' White (AK-759) or similar over the exposed fuselage sides and the rudder sides.

Remove all masking.

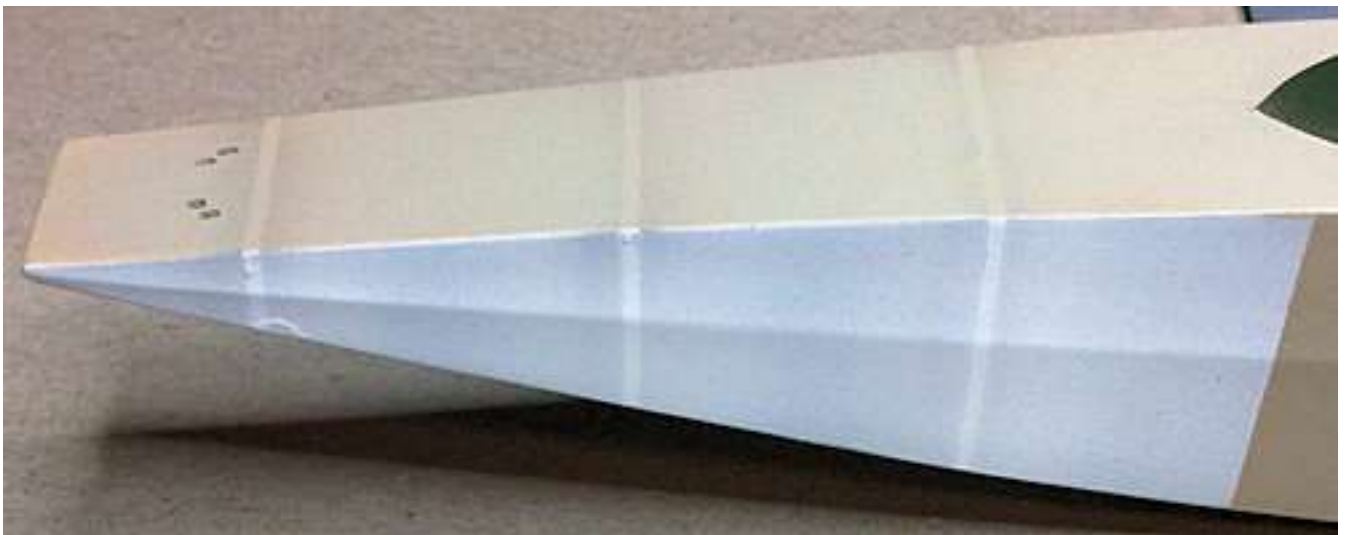

Metal green areas:

Refer to the previous illustrations and mask off all of the white and CDL areas on the fuselage, undersides of the lower wings and the wing root area on the upper surface of the lower wing, leaving just the fuselage forward panels, engine cowls and top rear decking panel exposed.

Airbrush a grey primer, such as 'AK Interactive Grey (AK-758) or similar over the exposed fuselage forward panels, engine cowls, top rear decking panel and the gun infill decking panel (A8).

Airbrush the same with 'Tamiya' J.A Green (XF13) or similar.

Remove all masking from the fuselage.



Camouflaged surfaces:

NOTES: *The green and brown camouflage for this particular aircraft was applied to the upper surfaces of the upper and lower wings and the upper surface of the elevators.*

Make sure the upper surfaces of the upper and lower wings and the elevators are smooth and free from surface imperfections.

Mask off the fuselage surfaces above the lower wings.

Airbrush a grey primer, such as 'AK Interactive Grey (AK-758) or similar over the upper surfaces of the upper and lower wings and elevator.

NOTE: *When airbrushing the upper surfaces of the wings and elevators, direct the airbrushing from above the surface and down towards the leading and trailing edges. This reduces the chance of paint spray on the already painted underside surfaces.*

The camouflage colours were sprayed onto the aircraft as opposed to be brush painted. As such the division between the two colours is not sharply defined, but rather airbrush blurred.

Refer to the colour illustration on the following page for the camouflage colour scheme.

Mask off the upper wing leaving just the white areas exposed.

Airbrush a white primer, such as 'AK Interactive Grey (AK-759) or similar

Mask off the white painted areas.

Airbrush a grey primer, such as 'AK Interactive Grey (AK-758) or similar over the top surfaces of the upper and lower wings and elevator.

Following the illustration scheme, airbrush the green areas of the top surfaces of the upper and lower wings and elevator with 'Tamiya' J.A Green (XF13) or similar.

Following the illustration scheme, airbrush the brown areas of the top surfaces of the upper and lower wings and elevator with 'Tamiya' Red Brown (XF64) or similar.

Remove all of the masking.

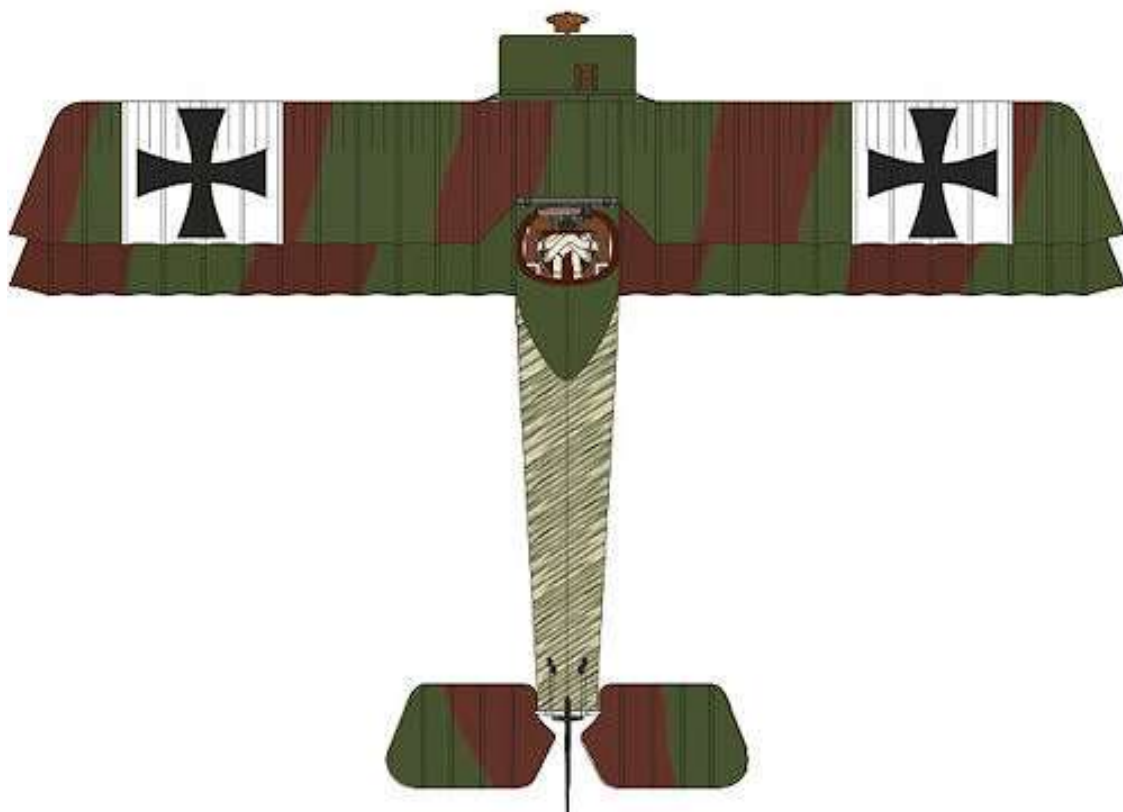

National markings:

NOTE: *I found that the supplied decal sheet is good, but there is a lot of unnecessary transparent carrier film around most of the decals. As these areas of carrier film have no colour, any air trapped under them can cause 'silvering', which will be obvious once the decal has dried and set. These areas of carrier film should be carefully cut away as close as you can to the decal **or as I chose, to create masks where possible.***

To create masks for the crosses on the wings, fuselage and rudder, I scanned the kit supplied decal sheet, then using 'Paint Shop Pro', enhanced, resized and saved them BMP files. These were imported into the software for my 'Cricut Explore Air2' crafters cutter. The masks were cut on 'Artool' Ultra Mask masking paper.

The masks were position onto the upper and lower wings, fuselage sides and the rudder sides.

Masking tape was added around each mask to prevent over spray.

Each cross was airbrush with 'Tamiya' NATO Black (XF69).

Before the paint fully dried, all masking and the masks were removed.



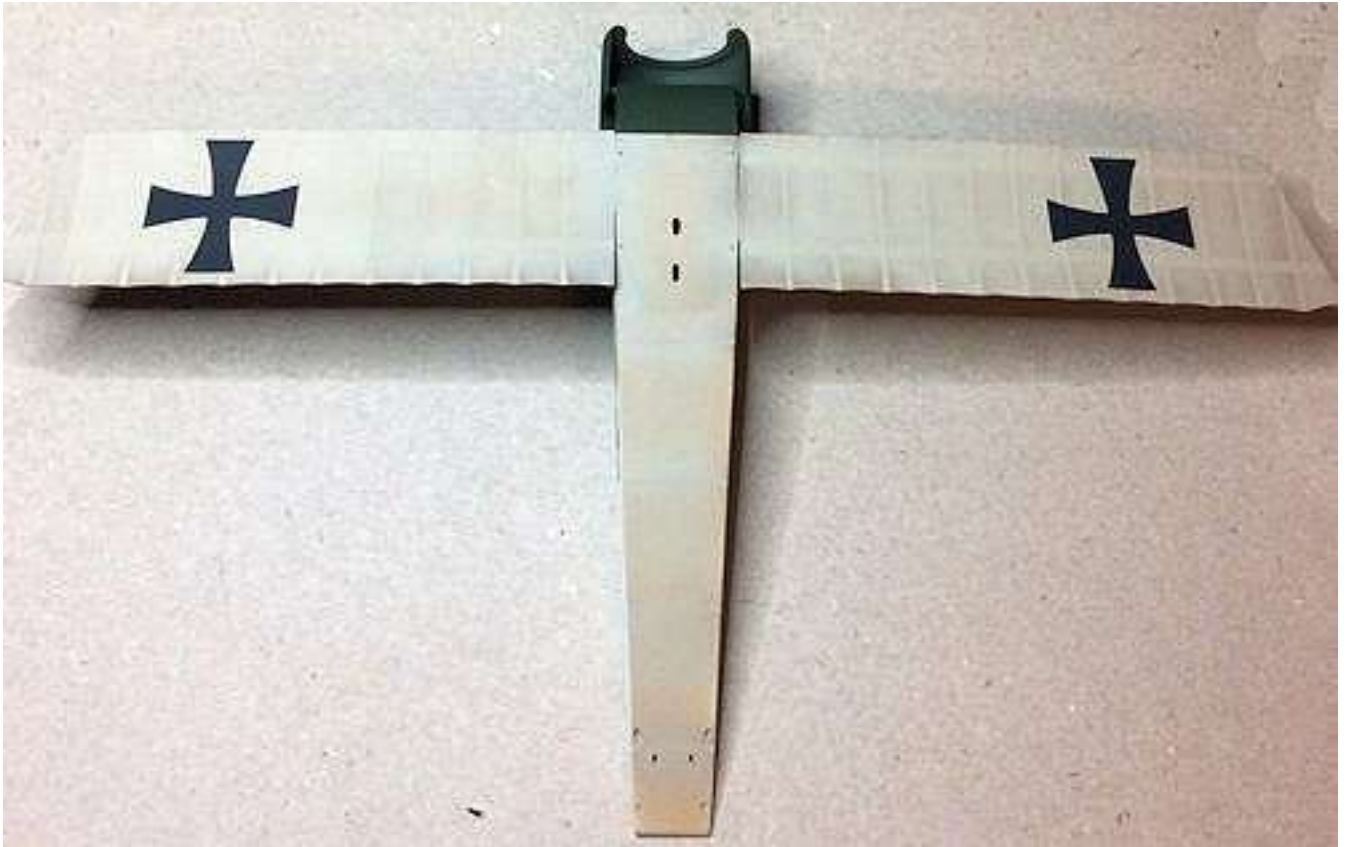

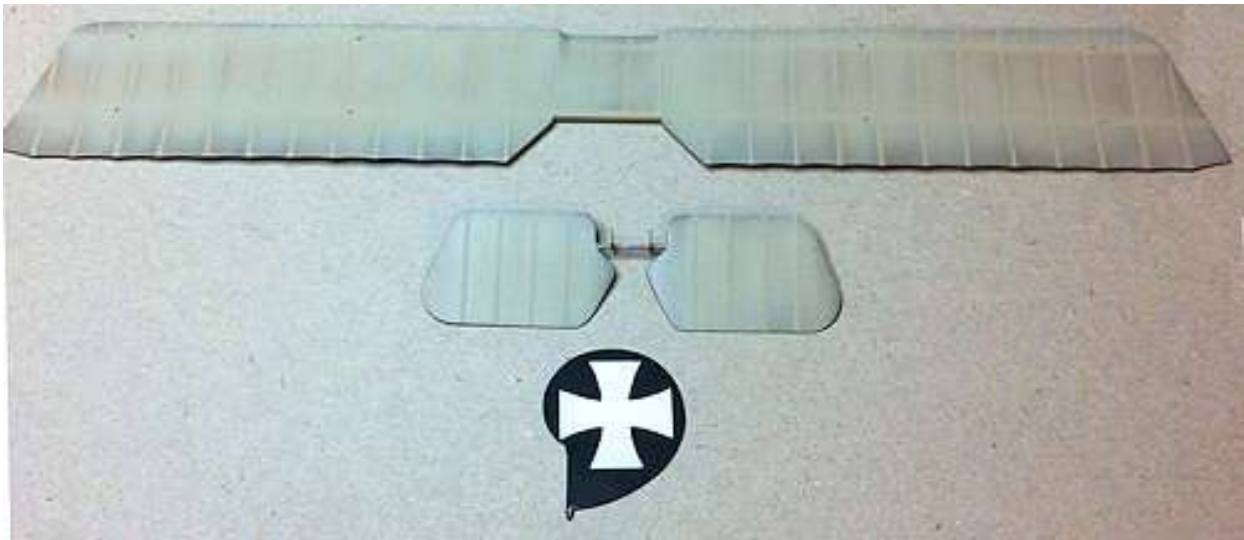

Engine cowls:

Brush paint the inside of the engine cowls, the two side panels and the forward under fuselage panel with 'Mr. Colour' Stainless Steel (213) or similar.

Elevator cross bar:

Brush paint the elevator cross bar and the four control horns with 'Tamiya' Semi-Gloss Black (X18) or similar.

Cockpit surround padding:

Brush paint the cockpit surround padding with 'Tamiya' Hull Red (XF9) with 'Humbrol' Leather (62) highlights.

Wing warp pulley control bar:

Brush paint the pulley control bar with 'Tamiya' J.A. Green (XF13).

Wheels:

Cement the two halves of both wheels together.

Sand the joints to blend the two half tyres together.

Airbrush the tyres on the two wheels with a grey primer, such as 'AK Interactive' Grey (AK-758) or similar.

NOTE: *To airbrush the front and rear wheel covers without over spraying the surrounding tyres, I use a circle drawing tool (Linex 1217 T). I selected the correct size of hole and position the wheel face under the hole.*

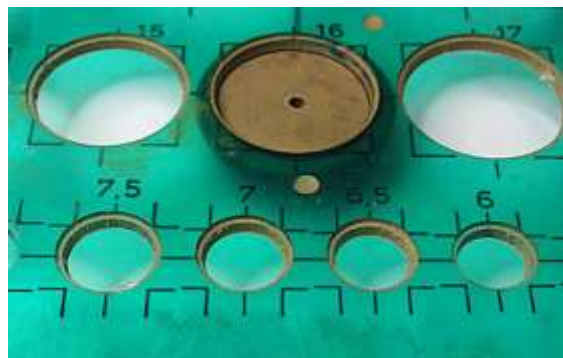

Airbrush the front and rear wheel covers with a white primer, such as 'AK Interactive' white (AK-759) or similar.

Decals:

NOTE: *As the crosses on the wings, fuselage and rudder were masked and painted, the only kit supplied decals to be used are the wheel decorations and the part of the serial numbers. The 'lift here' and data plate for the engine cowl were from spare 'Wingnut Wings' decals. The parts to have decals applied are:*

Fuselage/lower wing assembly, upper wing, elevators, rudder and the two wheels.

Make sure the painted surfaces of the parts are smooth and free from any surface imperfections.

NOTE: *Mask off the cockpit to prevent it being over sprayed with the gloss clear coat.*

To prepare the surfaces for applying decals, airbrush the surfaces of the parts with a clear gloss, such as 'Alclad' Aqua Gloss 600, 'Tamiya' Clear Gloss (X22) or similar. If necessary apply further, thin coats to achieve a smooth gloss finish.

Fuselage streaked decals:

NOTE: *Refer to Part 4 (Decals) of this build log for more information on decal application.*

*The linen effect decals from 'Aviatic' are not 'cookie' cut. **Therefore the outline of each decal to be applied must be cut accurately to shape before application.***

*The method used by the 'Fokker' company to streak camouflage their aircraft was by brushing the colours. On the fuselage it was normal practice to apply the streaks vertically on the sides of the fuselage, but at an angle on the top of the fuselage. The 'Aviatic' decals used are cut from the **ATT32058** decal sheet.*

A tip to help decals to adhere more to the painted surface is to stir in some PVA adhesive (white glue) into the decal water. When stirred in the water, it will disperse and form a weak adhesive, which, like plain water, is brushed onto the painted surface before the decal is applied.

Fuselage sides:

Cut out a paper template and test fit it onto the forward side of the fuselage.

Cut a streaked camouflage strip of your choice from the **ATT32058** decal sheet.

Lay the paper template onto the back of the linen effect decal sheet and trace the outline onto the decal sheet. Remember to reverse the paper template on the back of the decal sheet, otherwise you'll cut the opposite decal shape.

Carefully cut out the decal and apply it to the forward fuselage.

Repeat the procedure to apply decal to the opposite side of the fuselage.



Fuselage top:

NOTE: *The streaked camouflage for the top of the fuselage needs to be cut as sections from the two large squares (turtle deck and tail plane) of decal on sheet ATT32058. This is because the decals are not long enough and the streaking needs to be angled.*

Cut out two paper templates to cover the length of the top of the fuselage.

Test fit the templates onto the top surface of the fuselage.

Cut out the two large square decals from the decal sheet ATT32058.

NOTE: *The streaks on the cut decals need to be at an angle of approximately 30 degrees (refer to the illustration).*

Lay the paper templates onto the back of the square decals sheet and trace the template outlines onto the decal sheets. Remember to reverse the paper template on the back of the decal sheet, otherwise you'll cut the opposite decal shape. Also make sure the streaks on the two cut decals will be at the same angle.

Carefully cut out the decals and apply them to the top of the fuselage, making sure the join does not overlap.



Linen effect decals:

NOTE: *The 'Aviattic' decal used is ATT32236 and two sheets are required. The areas to be covered are both sides of the upper and lower wings, both sides of the elevators, both sides of the rudder, both sides of the wheels and the fuselage.*

A tip to help decals to adhere more to the painted surface is to stir in some PVA adhesive (white glue) into the decal water. When stirred in the water, it will disperse and form a weak adhesive, which, like plain water, is brushed onto the painted surface before the decal is applied.

*Refer to Part 4 (Decals) of this build log for more information on decal application. The linen effect decals from 'Aviattic' are not 'cookie' cut. **Therefore the outline of each decal to be applied must be cut accurately to shape before application.***

Upper wing - top surface:

Lay the top side of the upper wing onto the back of a blank sheet of paper.

Trace the outline of one side of the wing (inboard end at the edge of the wing centre section) onto the paper. Remember to reverse the paper template on the back of the decal sheet, otherwise you'll cut the opposite decal shape. Also remember to take into account the curve of the wing surface.

Cut out the paper template and test fit it onto the top surface of that side of the upper wing.

Lay the paper template onto the back of the linen effect decal sheet and trace the outline onto the decal sheet.

NOTE: *If when applying the decal you find it does not conform to a curved edge, brush a setting solution, such as 'MicroScale' MicroSol (red bottle) or if necessary, 'Tamiya' X20A thinners can be used, but should be applied sparingly as it will melt and weld the decal to the surface.*

Carefully cut out the decal and apply it to the wing surface.

NOTE: *After applying the decal, do not attempt to cut away any decal overhang at edges. Make sure the decal has not folded over the edge and adhered to the underside of the wing, as this will show darker when the underside decal is applied. Leave the decal overnight to fully dry and set, then decal overhang can be removed from the edges by either gently sanding (away from the decal, not towards it) or by cutting away using a sharp blade, such as a shielded razor blade.*

If necessary, remove any decal overhang at the edges.

Repeat the procedure to apply decal to the opposite side of the wing and the centre section.

Upper wing - underside:

Repeat the procedure to apply linen effect decal to the underside of the upper wing.

Lower wing - top surface:

Repeat the procedure to apply linen effect decal to the top surface of the lower wings.

Lower wing - underside:

Repeat the procedure to apply linen effect decal to the underside of the lower wings.

Fuselage rear side sections:

Repeat the procedure to apply linen effect decal to the fuselage left and right rear sections.

Rudder:

Repeat the procedure to apply linen effect decal to both sides of the rudder. Cut the decal to allow it to fit around the control horns.

Elevators:

Repeat the procedure to apply linen effect decal to both sides of the elevators.

NOTE: *The fuselage underside decal will require application of setting solution to conform it over the photo-etch. If necessary dab, don't brush, 'Tamiya X20A thinners.*

Fuselage underside:

Repeat the procedure to apply linen effect decal to the underside of the fuselage.

If the decal traps air or water along the added photo-etch 'stitching', prick holes through the decals along the stitching and apply decal solvent, such as 'MicroScale' MicroSol or if necessary sparingly 'Tamiya' X20A thinners.

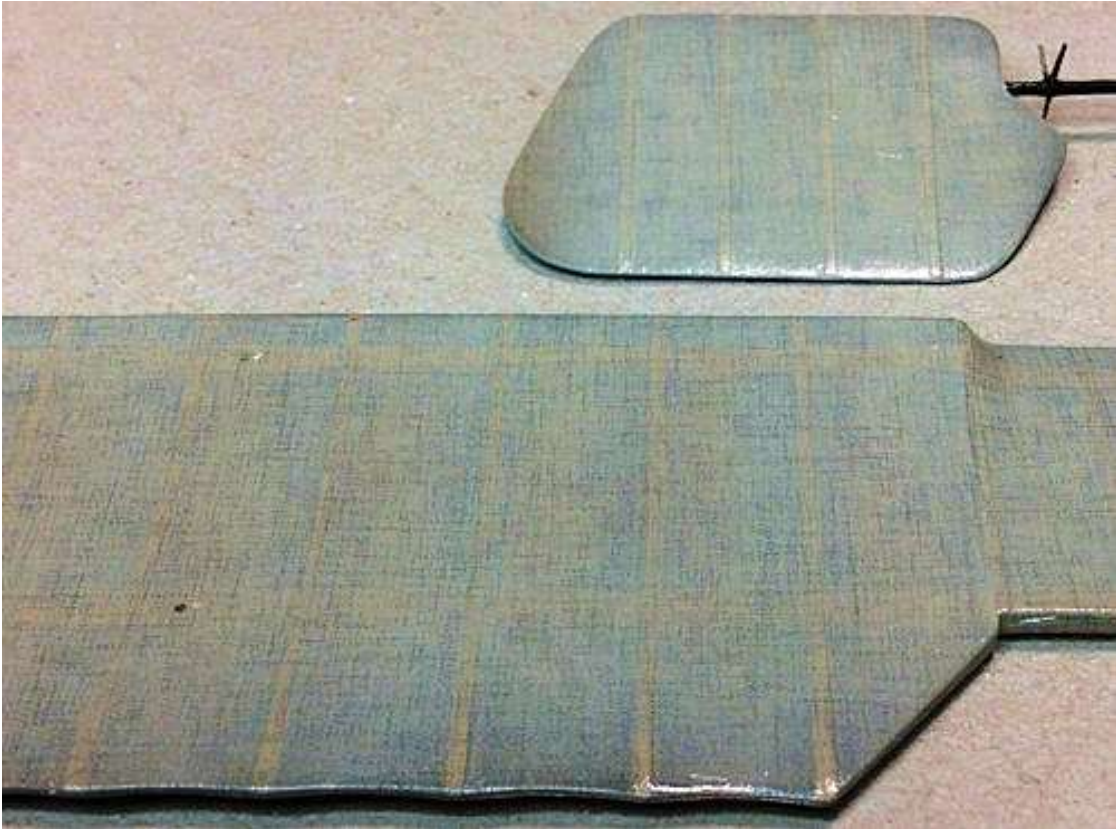

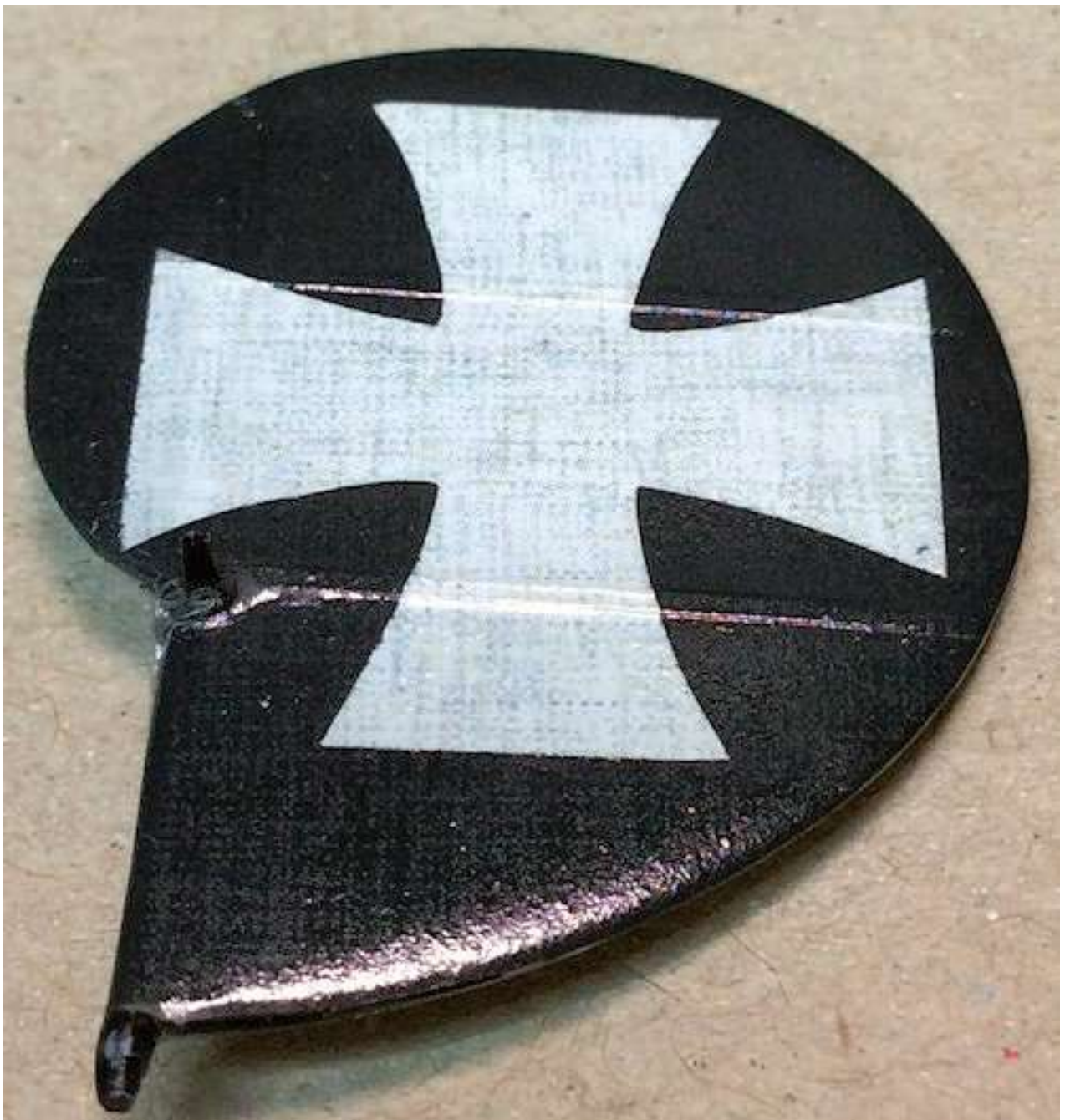

Wheel covers:

NOTE: To cut discs from decal sheets I use a 'ThinnerLine' circle cutter. There is also a similar tool available from 'DSPIAE'.

'Thinnerline' circle cutter



Cut four discs of the same diameter as the wheel covers.

Cut or drill a hole in the centre of each disc such that they can fit over the hubs in the centre of the wheels.

Cut a shallow segment in each decal, from the centre hole to the outer edge. This will allow the decal to conform to the slight curve of the wheel covers.

Apply the two kit supplied decals onto the outer wheel covers.

Apply the linen decals to the front and rear wheel covers.

Brush paint the centre hubs on both sides of the wheels with 'Tamiya' Sem-Gloss Black (X18) or similar.



Remaining decals:

Refer to the following illustration and apply the data plate decals to the right side only of the engine cowl.

Refer to the following illustration and apply the two 'lift here' decals to each side of the fuselage, at the lower, rear edges.

NOTE: *As the serial number of this particular aircraft is not known, the kit supplied decals were used, but cut to remove the serial numbers, leaving separate 'Fok. DII' and '/16' decals.*

Refer to the following illustration and apply the two 'Fok. DII' decals to each side of the fuselage, at the lower edges.

Refer to the following illustration and apply the two '/16' decals to each side of the fuselage, at the lower edges and spaced back from the 'Fok. DII' decals.

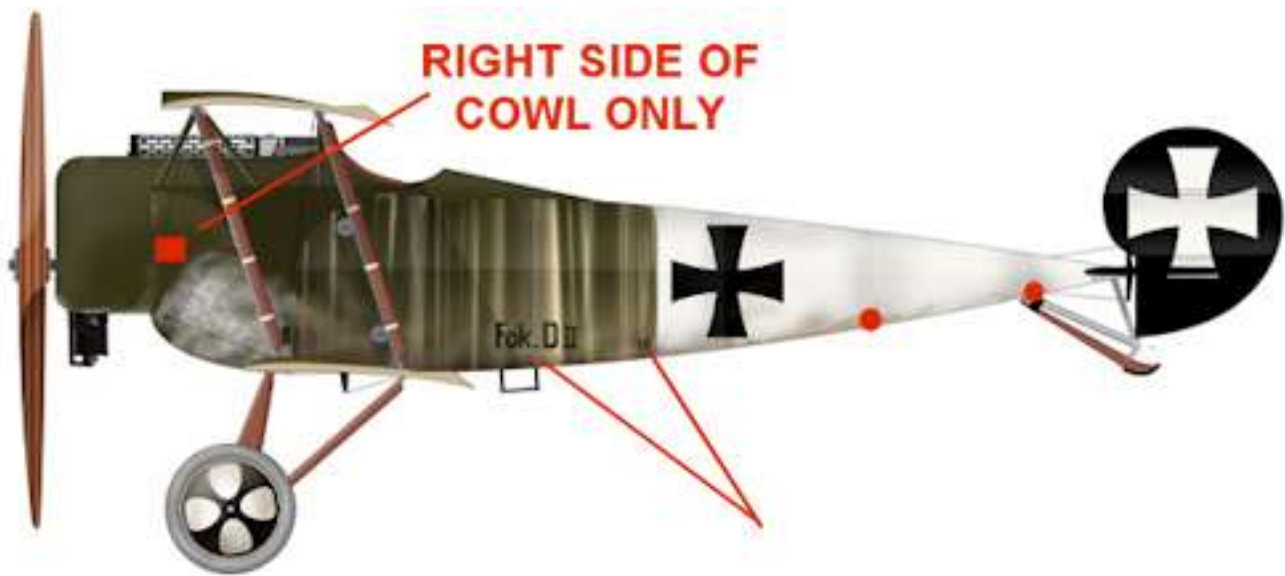

Weathering:

NOTE: *Refer to Part 3 (Weathering) for more information on weathering. The weathering to be applied covers:*

Erosion of the painted and doped surfaces.

General grime over the aircraft.

Engine exhaust/oil stains.

General dirt.

NOTE: *If in doubt of to apply erosion, practice first on scrap plastic card to perfect the technique. Too much paint applied will cover the base coat and result in a metal looking finish, rather than eroded paint.*

Paint erosion:

To represent the paint erosion, exposing the metal surface to the rear of fuselage side cowl panels, use either a small piece of fine sponge or a short cut down brush to stipple (gently dab) 'Tamiya' Flat Aluminium (XF16) or similar onto the green area to the rear of the panels, but not onto the streaked decal areas.

Doped linen erosion:

Use the same technique, but with 'Tamiya' Deck Tan (XF55), to represent the dope erosion on the streaked linen at the rear of the fuselage forward metal panels.

General grime:

Airbrush the fuselage/lower wing assembly, upper wing, elevators, rudder and both wheels with a semi-matte clear coat, such as 'Alclad' Light Sheen (ALC-311), 'Tamiya' Semi-Matte (X35) or similar.

Refer to Part 3 (Weathering) of this build log. Brush the parts with 'Flory Models' Dark Dirt fine clay wash.

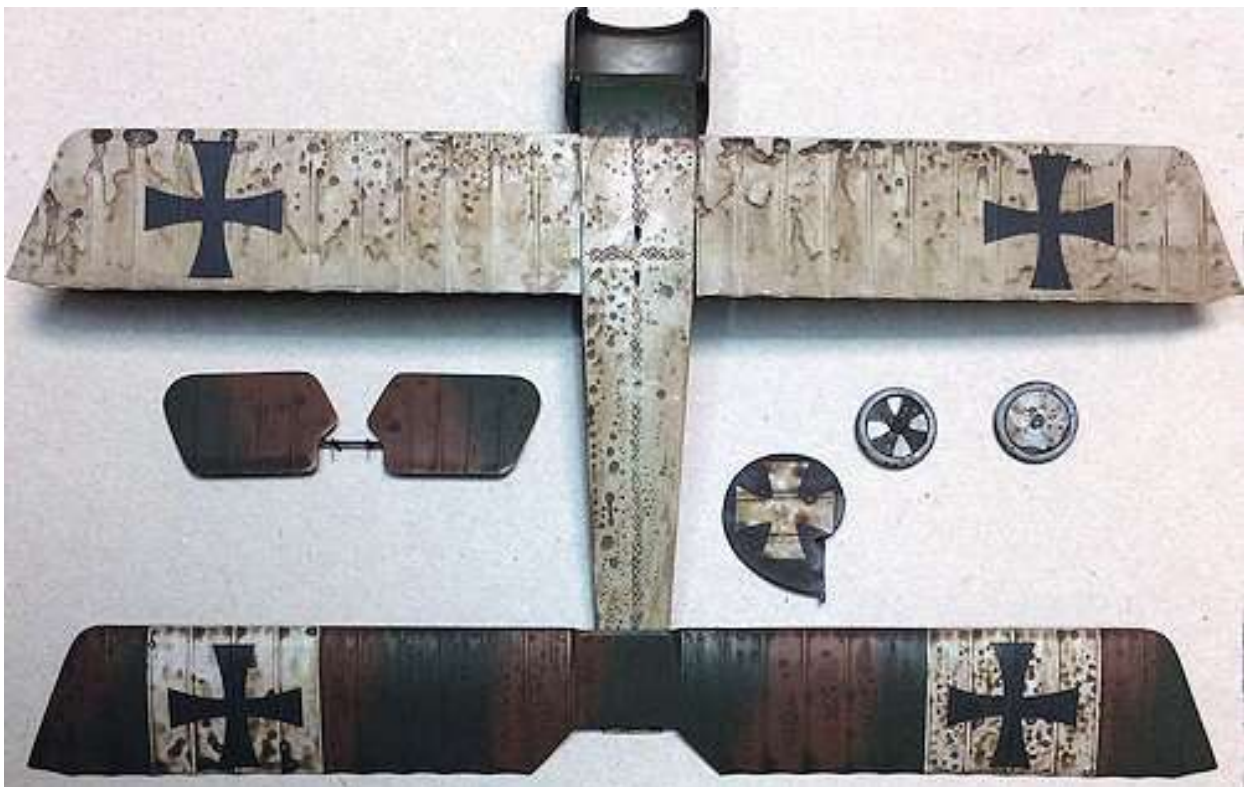

Once dry, remove to your desired finish.

To seal the applied wash, a light coat of a semi-matte clear coat, such as 'Alclad' Light Sheen (ALC-311), 'Tamiya' Semi-Matte (X35) or similar.

Engine exhaust/oil stains.

Brush 'AK Interactive' Engine Oil (2019) wash over the engine bulkhead and inside the engine cowl to represent oil spray. Also the fuselage forward under panel as streaked oil stains flowing rearwards.

General dirt:

Sponge apply 'Tamiya' Weathering Master Set A (Mud) as desired across areas such as the trailing edge wing root of left lower wing and along the bottom edge of the fuselage.

NOTE: *The following photographs were taken with the pilot figure and engine test fitted only.*





Cowl band:

NOTE: *The engine cowl was held in position by a retaining band clamped to the lower edge on both sides of the cowl. The strap needed to be defined more as parts of this pre-moulded band were sanded away during earlier construction.*

Cut a 1.0 mm wide strip from the 'Xtradecal' Parallel Stripes (Black XPS1) decal set.

Apply the decal strip around the rear edge of the engine cowl.

Conform the decal to the surface by applying 'MicroSet' MicroSol over the decal.

Once the decal has fully set, secure the two photo-etch clamps (PP25) to both ends of the decal strap, using thin CA adhesive.

To blend the decal strap and end clamps to the surrounding area, mask the surrounding areas then **lightly** airbrush 'Tamiya' Green (XF13) over the strap **but do not completely cover** the strap with paint.

Pilot figure - fit:

NOTE: Refer to Part 12 (Figure) for the preparation and painting of the pilot figure. At this stage of the build the pilot figure must be fitted into the cockpit, so that the machine gun can then be fitted. Otherwise the weapon will obstruct the fitting of the pilot.

Locate the pilot figure fully into the cockpit.

If possible, secure the pilot figure in position by applying thin CA adhesive under each arm where they rest on the cockpit surround padding.

NOTE: Decking panel insert (kit part A7) and photo-etch strip (PP10) are not used for this particular model build.

Cement the decking insert panel (A8) in position in the cockpit front decking.

Check the insert panel is flush with the surrounding area. If not, apply a modelling putty filler over the panel and when set, sand to make the area flush, then mask off the area, the pilot figure and under the front decking panel. Reprime, repaint and reseal that area to match (i.e. 'Tamiya' Green [X13]).

Machine gun:

NOTE: Refer to Part 8 (Weapons) for preparation and painting of the machine gun.

Cement the machine gun into its locating slot in the front decking panel, making sure the machine gun is level with the fuselage when viewed from the side and parallel to the fuselage when viewed from above.

NOTE: The machine gun was fitted with an empty ammunition belt chute, which routed the empty belt down and back into a container in the cockpit area. This chute is not supplied in the kit.

To represent the empty ammunition belt chute, I used part of a spare ammunition drum from a 'Wingnut Wings' Parabellum machine gun. The drum was cut to shape so that it could be located against the breech outlet and onto the cockpit forward decking panel.

Airbrush the ammunition feed chute (kit part C35), created empty belt chute and the ammunition belt (from the 'GasPatch' early LMG 'Spandau' 08 set) with a grey primer, such as 'AK Interactive' Grey (AK-758) or similar.

Airbrush the ammunition feed chute with 'Alclad' Duraluminium (ALC120) or similar.

Airbrush the empty belt chute with 'Tamiya' Green (XF13).

Brush paint the ammunition on the belt with 'Tamiya' Deck Tan (XF78) or similar.

Brush paint both ends of each ammunition round with 'Mr. Colour' Brass (219) or similar.

Clear paint and primer from the contact surfaces for the ammunition feed and empty belt chutes and the fuselage.

Cement the ammunition feed and empty belt chutes onto the fuselage and against the breech blocks of the machine gun.

Trim the length of the 'GasPatch' ammunition belt such that it can be located onto the feed chute. Secure the ammunition belt in position on the feed chute, using thin CA adhesive.



PE outlets:

Airbrush the photo-etch outlet surrounds (PP5) for the rudder and elevator control lines with 'Humbrol' Leather (62) or similar.

Secure a photo-etch outlet surround over each of the control line outlets on the top and bottom of the fuselage rear, using a PVA adhesive, such as 'MicroScale' Kristal Klear or similar. This will secure the parts in position and will dry clear, allowing you to move the parts into position and when set, will allow you to see and clear the fuselage openings if necessary.

Once the adhesive has set, check that the openings within the outlet surrounds are clear, so control lines can be inserted later in this build.



Transportation posts:

Brush paint the four fuselage discs for the 'posts' with 'Tamiya' Sky Grey (XF19) or similar.

Prepare eight 'Gaspatch' turnbuckles (one end type), making sure the holes in the 'eye' ends are clear.

Refer to the photographs below and snip the tang ends of the turnbuckles such that they represent the length of the 'posts' when inserted into their pre-drilled holes in the fuselage and lower wings. Test fit the turnbuckles and if necessary, increase the size of their locating holes.

Using thin CA adhesive, secure the eight transportation 'posts' into their pre-drilled holes in the lower wing and sides of the fuselage. Make sure the 'posts' are correctly orientated (refer to the following photographs). When the aircraft was operational, the fuselage 'posts' would be fitted with the 'eye' ends aligned with the fuselage (horizontal) and the 'posts' in the lower wings with their 'eye' ends aligned across the chord of the wings.

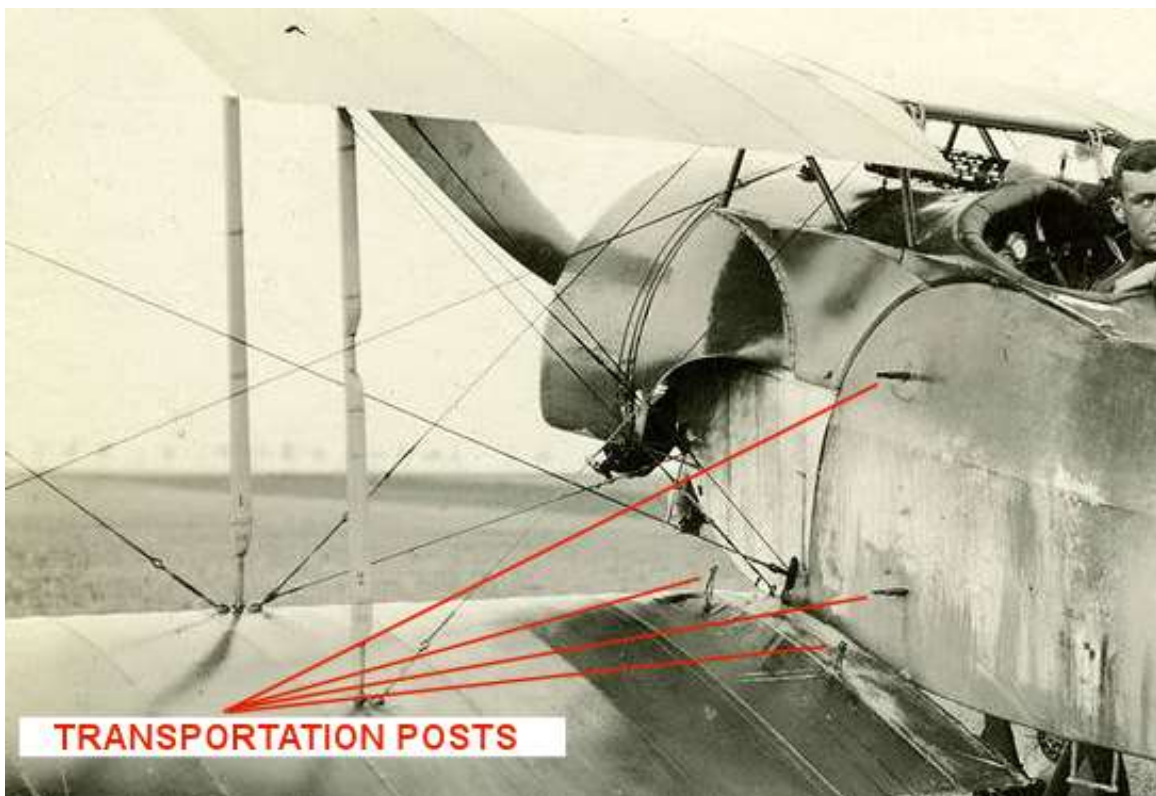

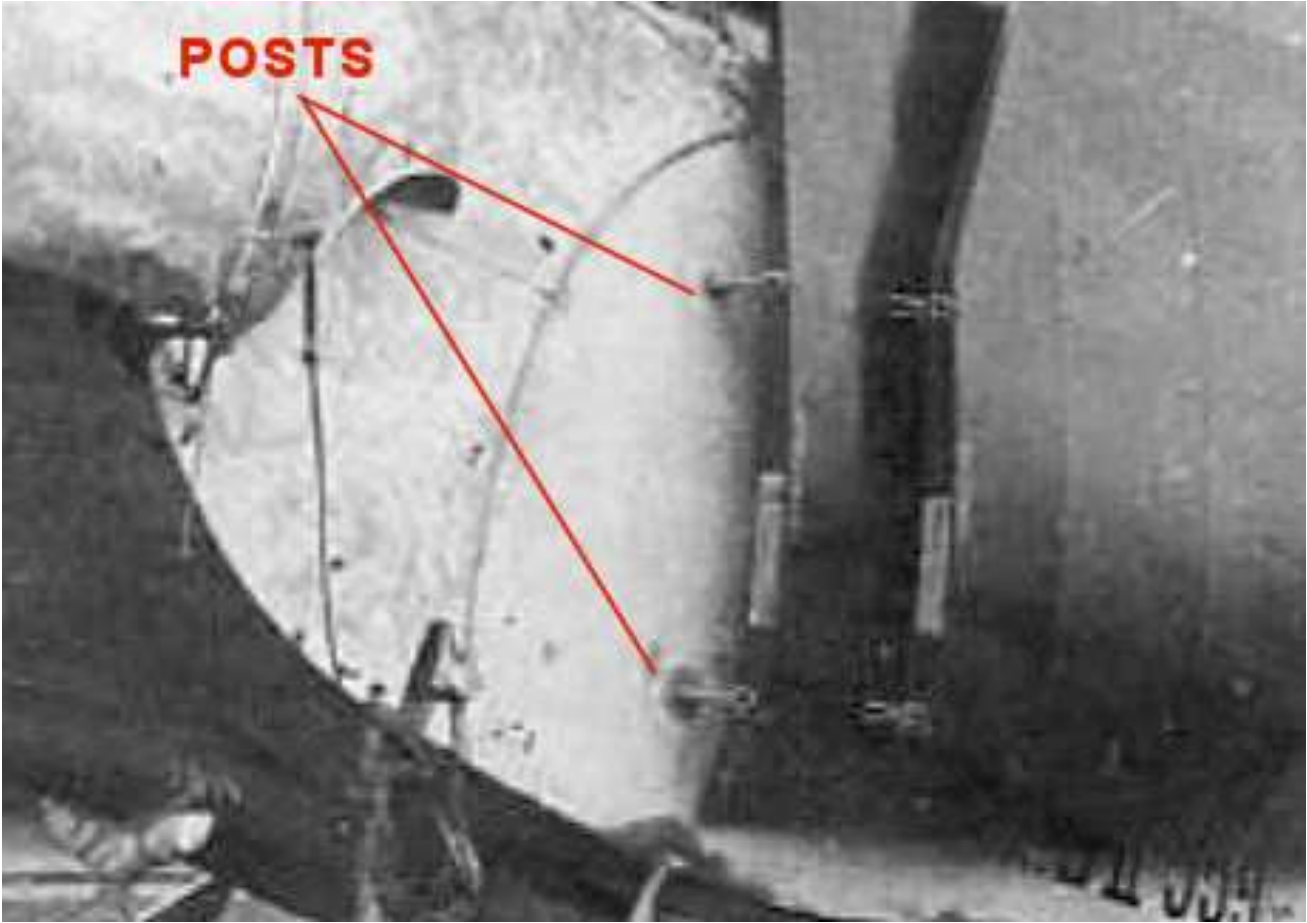

Interplane struts:

NOTE: *The eight interplane struts need modification to replace the reinforcing wrappings around the interplane struts as they are too thick. Also the wooden struts had a metal reinforcing rod along their leading edges, which are not represented on the kit struts. It's not clear from photographs of the actual aircraft to determine the type of 'wrappings' around the struts. Normally these would have been made of linen, but it's possible for this aircraft they were metal. **I chose to represent the 'wrappings' as linen.***

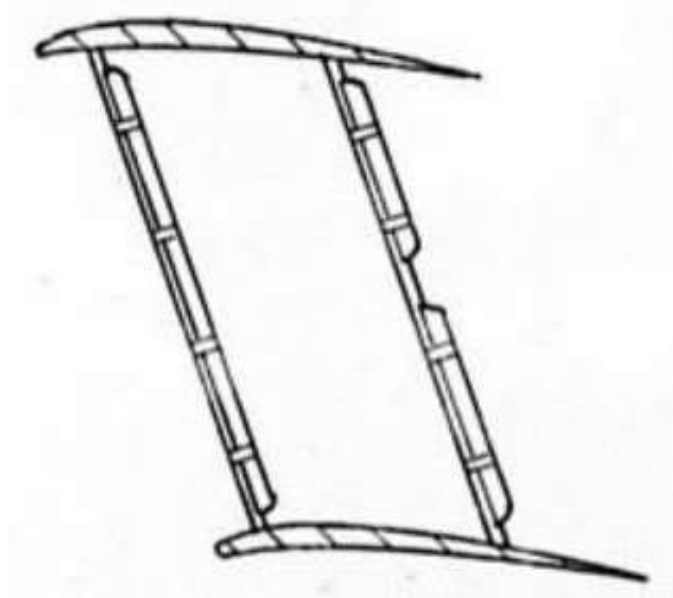

Carefully sand down the wrapping tapes around the eight interplane struts to the surface of the struts.

Scribe along the leading edges of the interplane struts to represent the reinforcing rods.

Airbrush the interplane struts with a grey primer, such as 'AK Interactive' Grey (AK-758) or similar.

Airbrush the interplane struts with 'Tamiya' Deck Tan (XF78).

Refer to Part 2 (Wood Effects) of this build log and apply wood effects to the interplane struts. I used 'DecoArt' Burnt Umber acrylic paint.

Airbrush the interplane struts with a clear gloss coat, such as 'Alclad' Aqua Gloss 600, 'Tamiya Clear Gloss (X22) or similar.

Mask off the 'wood effect' of the struts to leave the leading edge rods exposed and airbrush the rods with 'Alclad' Steel (ALS112) or similar.

Cut a 1.0 mm wide decal strip from the 'Xtradecal' Parallel Stripes (White XPS2) decal set into 7 mm lengths.

Apply the decal strips around the interplane struts, as shown on the illustration above.

Refer to Part 3 (Weathering) of this build log. Brush the parts with 'Flory Models' Dark Dirt or Grime fine clay wash.

Once dry, remove to your desired finish.

To seal the applied wash, a light coat of a semi-matte clear coat, such as 'Alclad' Light Sheen (ALC-311), 'Tamiya' Semi-Matte (X35) or similar.



Fuselage cabane struts:

Airbrush the two fuselage cabane 'V' struts with a grey primer, such as 'AK Interactive' Grey (AK-758) or similar.

Airbrush the two fuselage cabane 'V' struts with 'Tamiya' J.A. Green (XF13).

Landing gear:

Airbrush the landing gear assembly with a grey primer, such as 'AK Interactive' Grey (AK-758) or similar.

Airbrush the landing gear assembly with a semi-matte clear coat, such as 'Alclad' Light Sheen (ALC311), 'Tamiya Clear Semi-Matte (X22) or similar.

Refer to Part 3 (Weathering) of this build log and apply weathering to the landing gear assembly. I used the 'Flory Models' Dark Dirt clay wash, but the Grime could be used instead.

Seal the applied weathering with a semi-matte clear coat, such as 'Alclad' Light Sheen (ALC311), 'Tamiya Clear Semi-Matte (X22) or similar.

Tail skid:

Airbrush the tail skid strut assembly and the tail skid with a grey primer, such as 'AK Interactive' Grey (AK-758) or similar.

Airbrush the tail skid strut with 'Tamiya' Deck Tan (XF55) or similar.

Refer to Part 2 (Wood Effects) of this build log and apply your chosen wood effect. I chose to brush with 'DecoArt' Burt Umber.

Brush paint the mounting point and 'shoe' of the tail skid with 'Mr. Metal' Stainless Steel (213) or similar.

Wing warp control pulley frame:

Remove parts PP19 (x 4) and PP20 (x 2) from their sheet and remove any residual photo-edge tags.

Bend the two pulley brackets (PP20) around the cross bar of the support frame, such that they can fit over the pre-moulded pulleys at each end of the bar.

Secure a pulley wheel (PP19) onto each side of the pre-moulded pulleys on the support frame, using thin CA adhesive.

Secure the pulley support brackets onto the support bar and photo-etch pulley wheels, using thin CA adhesive.

NOTE: *When airbrushing primer and paint onto the wing warp support frame assembly, make sure only light coats are applied, otherwise the fine detail of the photo-etch pulleys will be filled.*

Airbrush the wing warp control pulley frame assembly with a **light coat** of grey primer, such as 'AK Interactive' Grey (AK-758) or similar.

Carefully brush paint the two control pulleys with 'Mr. Colour' Stainless Steel (213) or similar.

NOTE: *The following step is necessary to allow rigging lines to be routed across the two wing warp pulleys.*

Make sure there is a slight gap between the top of the four photo-etch pulleys the their pre-moulded pulleys on the frame. If necessary, use a 0.2 mm diameter drill to create the gaps.

Pre-rigging:

NOTE: *To allow easier final rigging of the assembled model, pre-rigging should be carried out for both sides of the aircraft.*

*Preparing the pre-rigging for the **wing warping 'reaction cables' and their pulley support frame, the rudder and elevators are detailed separately***

Refer to the following illustrations and the model assemblies to determine the length required for each rigging line, which should be longer than the span of the finally fitted wires.

Pre-rigging location holes:

Prepare the upper and lower wings and the fuselage for attaching rigging by drilling holes of 0.3 mm diameter into the fuselage and into, but not through, the upper surface of the lower wings and the underside of the upper wing. Refer to the following illustrations for the location of the required pre-rigging holes

Drift wires

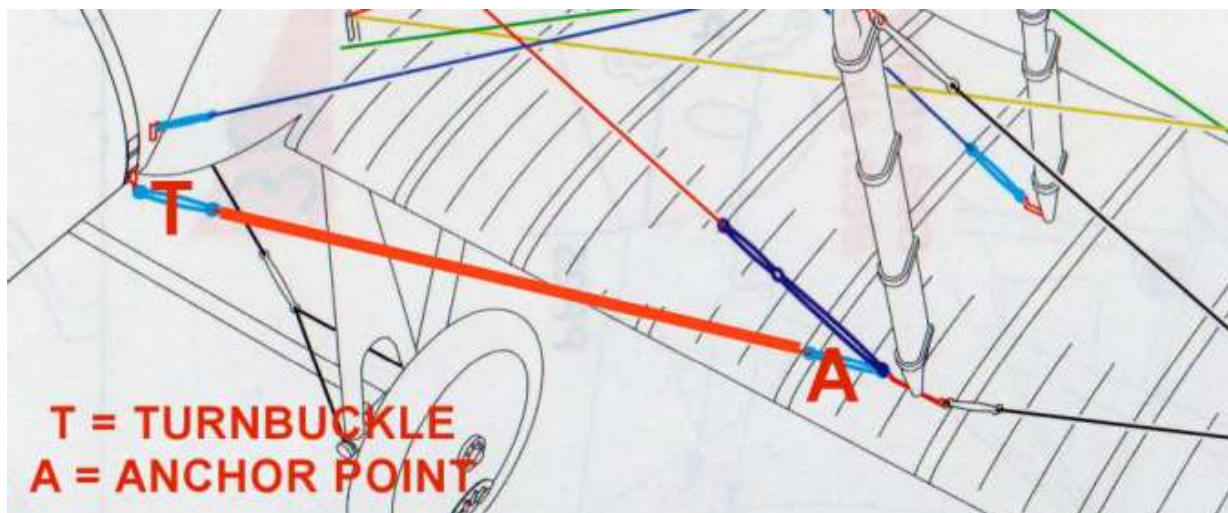

Flying wires

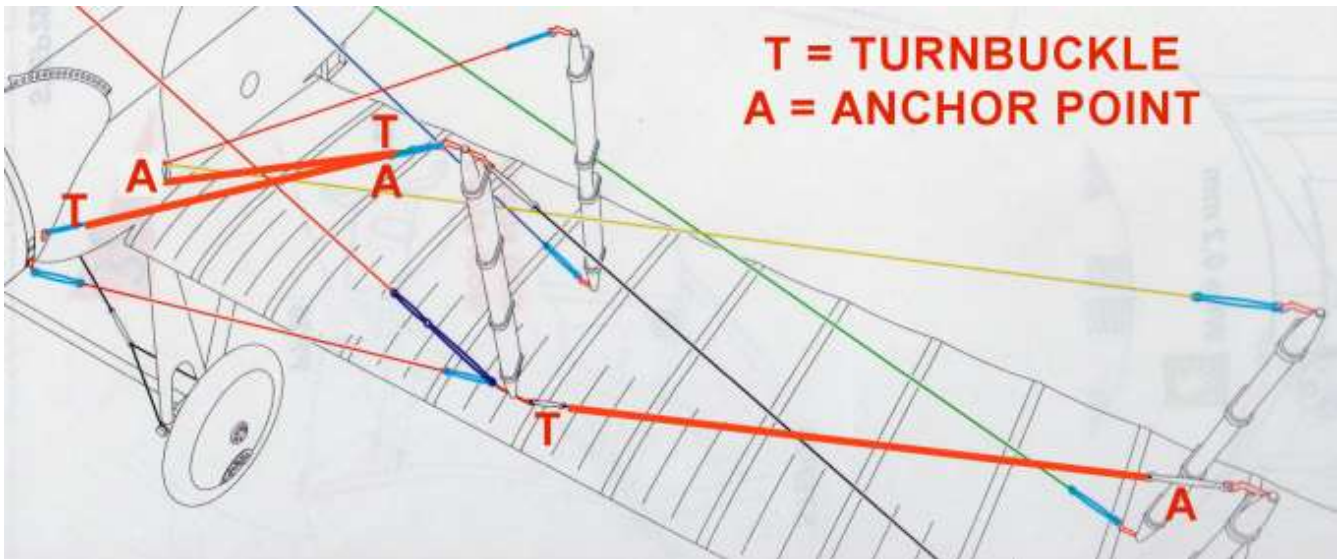

Landing wires

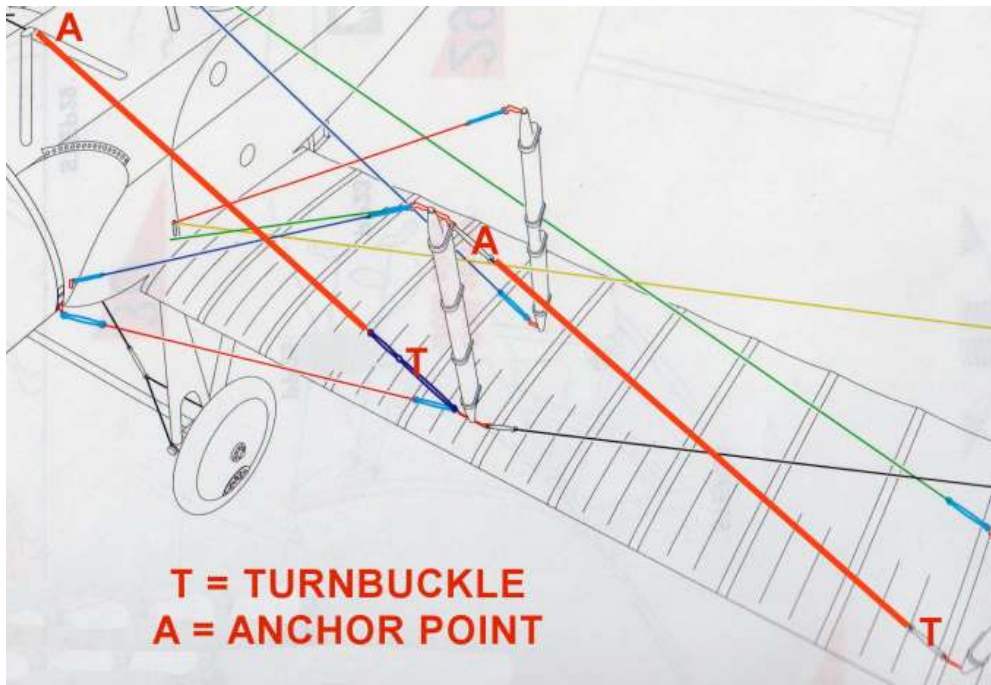

Landing gear

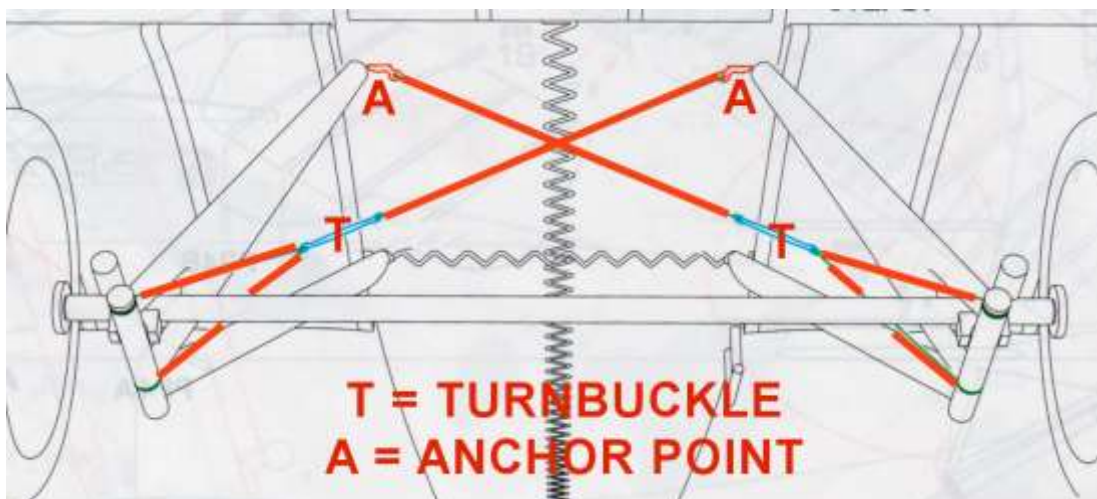

Fuselage cabane wires

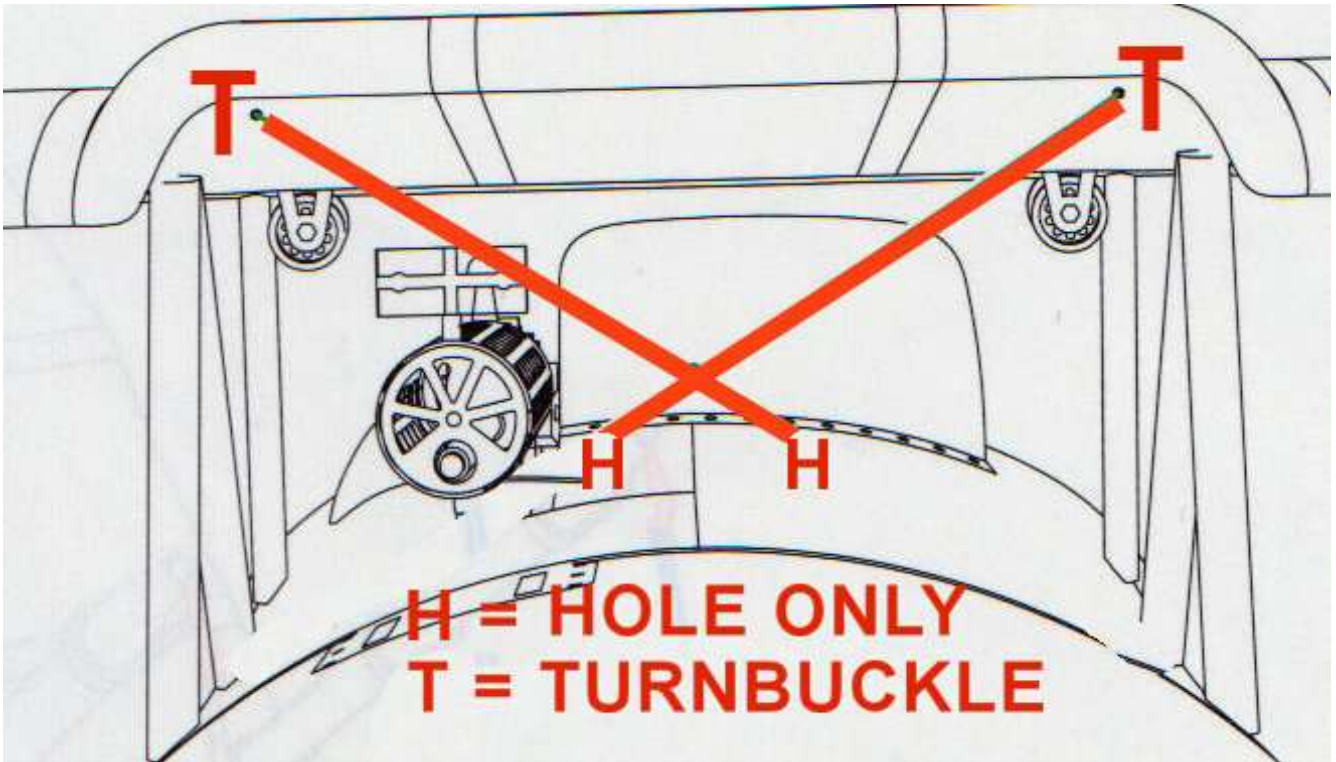

Wing warping 'control wires' only

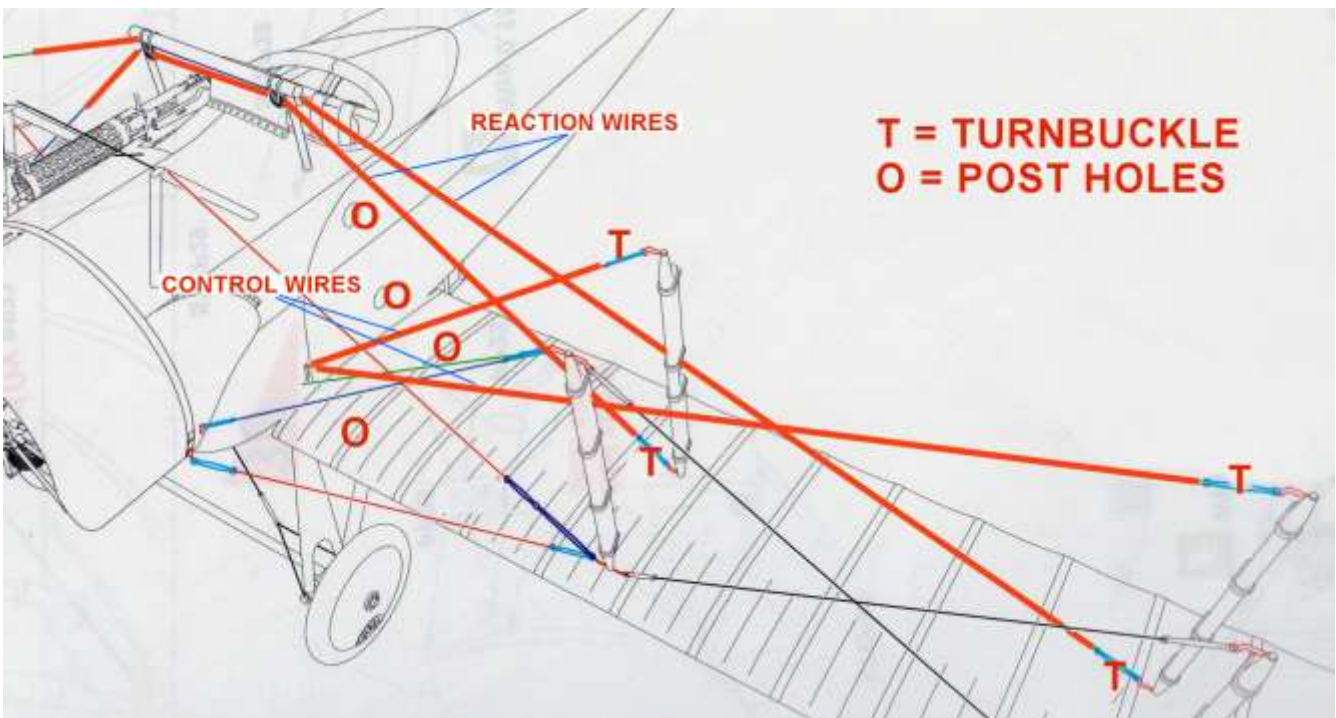

Pre-rigging a line:

Cut a length of 'Stroft' 0.12 mm diameter mono-filament or similar. The length should be long enough to be fitted to the aircraft, as indicated in the above illustration.

Pass one end of each line through a blackened 0.5 mm diameter Brass tube, such as 'Albion Alloy's' MBT05 or similar.

Pass the lines through the 'eye' end of 'GasPatch' 1:48th scale turnbuckle (Type C).

Pass the lines back through the tube.

Move the tubes up to, but not touching' the 'eye' end of the turnbuckles.

Secure the tubes to the lines using thin CA adhesive.

Cut away the residual tags of line.



Required pre-rigged lines:

Refer to the previous rigging illustrations and note how many rigging lines terminate with a turnbuckle (denoted by the letter 'T').

Cut long lengths of 'Stroft' 0.12 mm diameter mono-filament or similar. The length of the lines should be longer than that of the fitted line. This will allow extra line for final attachment.

Attach a 'GasPatch' turnbuckle (Type C) to each line, as described in the previous 'Pre-rigging a line' paragraph, **except for the two drift wires**, which should have 'One End' type turnbuckles fitted.

Wing warping 'reaction' wires:

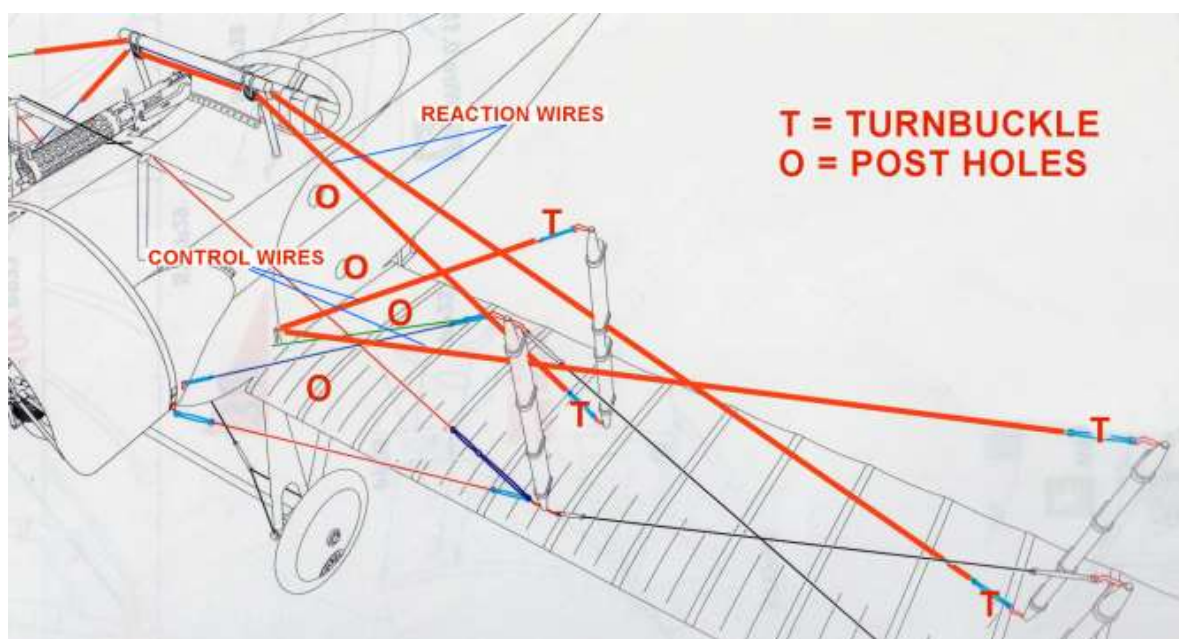

Pass one end of a line through a blackened 0.4 mm diameter Brass tube, such as 'Albion Alloy's' MBT04 or similar.

Pass the line through the 'eye' end of a 'GasPatch' 1:48th scale turnbuckle (Type C).

Pass the line back through the tube.

Move the tube up to, but not touching' the 'eye' end of the turnbuckle.

Secure the tube to the line using thin CA adhesive.

Cut away the residual tag of line.

Pass the free end of the line through the pre-drilled holes on the same side and above the wing warp control pulleys on the support frame.

Repeat the above procedure to add a tube and Type C turnbuckle to the free end of this line, **but do not secure this tube to the line** (to be carried out during final rigging).

Repeat the procedure to add a control line across the two pulleys on the other side of the support frame.

NOTE: *The support frame and reaction wires can't be finally fitted until the upper wing has been fitted.*

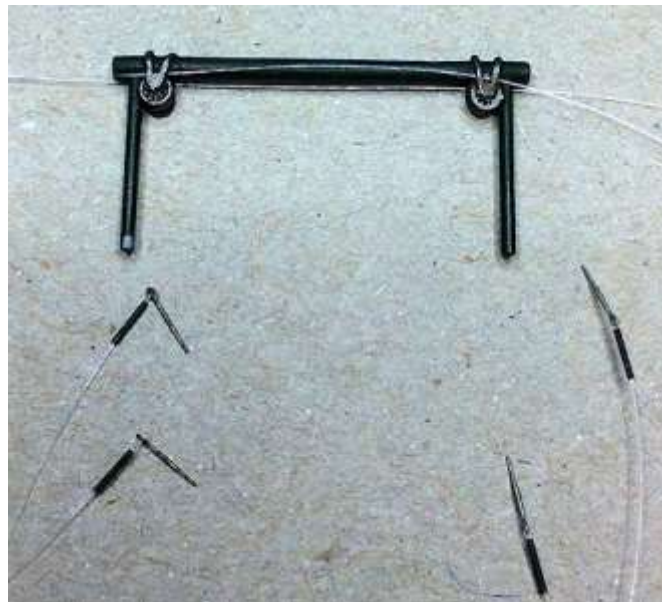

Rudder control cables:

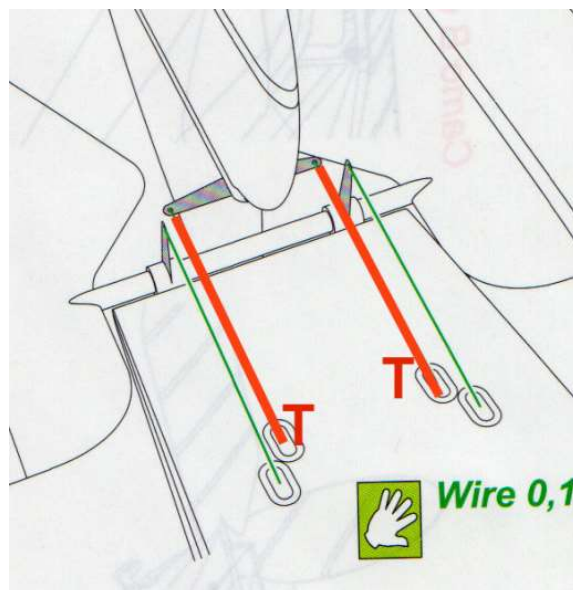

Cut two long lengths of 'Stroff' 0.08 mm diameter mono-filament or similar. The lengths should be long enough to be fitted to the rudder, as indicated in the previous illustration.

Pass one end of a line through a blackened 0.5 mm diameter Brass tube, such as 'Albion Alloy's' MBT05 or similar.

Pass the line through the hole in the end of a rudder control horn.

Pass the line back through the tube.

Pass the other end of the line through the 'eye' end of a 'GasPatch' 1:48th scale turnbuckle (Type C).

Pass that line back through the tube.

Move the tube up to, but not touching' the 'eye' end of the turnbuckle.

Move the other tube up to, but not touching' the 'eye' end of the turnbuckle.

Secure the tube to the lines using thin CA adhesive.

Cut away the residual tag of line.

Pass one end of the remaining line through a blackened 0.5 mm diameter Brass tube, such as 'Albion Alloy's' MBT05 or similar.

Pass the line through the other 'eye' end of the 'GasPatch' 1:48th scale turnbuckle (Type C).

Pass that line back through the tube.

Move the tube up to, but not touching' the 'eye' end of the turnbuckle.

Secure the tube to the lines using thin CA adhesive.

Cut away the residual tag of line.

Repeat the procedure to add a control line to the other side of the rudder.

NOTE: *The free end of the control lines will be finally fitted later in this build.*



Elevator control cables:

Cut four long lengths of 'Stroft' 0.08 mm diameter mono-filament or similar. The lengths should be long enough to be fitted to the elevators and into the openings in the fuselage, as indicated in the previous illustration.

Add a control line to the four control horns for the elevator, as described for the rudder control cables.

NOTE: *The free end of the control lines will be finally fitted later in this build.*

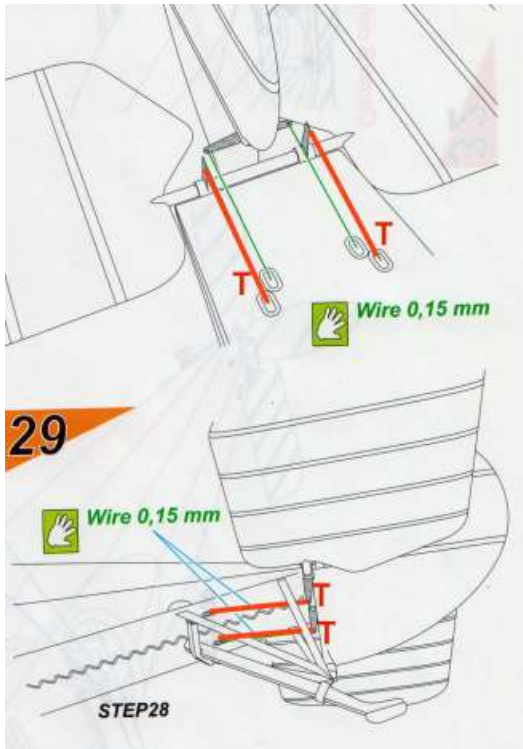

Pre-rigged lines - fit:

NOTE: *Only those pre-rigged lines that will be difficult to fit with the upper wing located will be fitted at this stage. The following rigging will be attached after the upper wing has been fitted:*

Drift wires

Forward flying wires

Wing warping 'reaction wires (with pulley support frame)

Landing gear bracing

Rudder and elevator control cables.

Upper wing:

NOTE: *Make sure you fit the correct length of pre-rigged line to its correct anchor point.*

Cut a length of 'Stroft' 0.12 mm diameter mono-filament or similar.

Pass the line through a short length of blackened 0.5 mm diameter tube, such as 'Albion Alloy's MBT05 or similar.

Pass the line through the free 'eye' of the type C turnbuckle attached to the rigging line.

Pass the line through the relevant anchor point on the underside of the upper wing.

Loop both ends of the 0.08 mm diameter mono-filament back through their end of the 0.5 mm diameter tube.

Pull the two ends of the 0.08 mm diameter line to draw it between the anchor point and the 'eye' of the turnbuckle.

Make sure the 0.08 mm tube is not too close to the anchor point.

Secure the tube to the lines at the anchor point end of the 0.5 mm diameter tube, using thin CA adhesive.

Carefully cut away the residual tags of 0.08 mm diameter line.

Repeat the procedure to attach a pre-rigged turnbuckle line to the eight anchors (4 each side) on the underside of the upper wing, as shown of the following photograph.

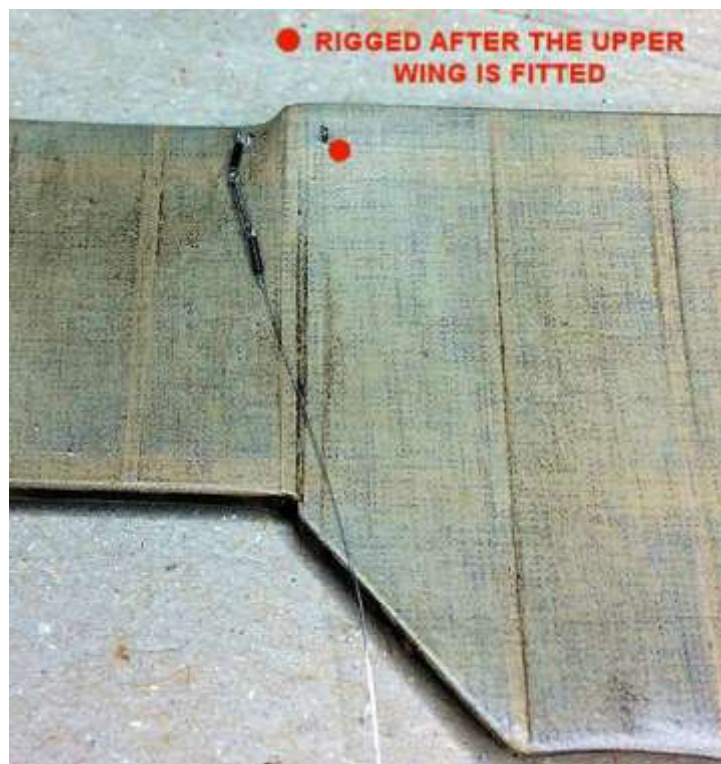
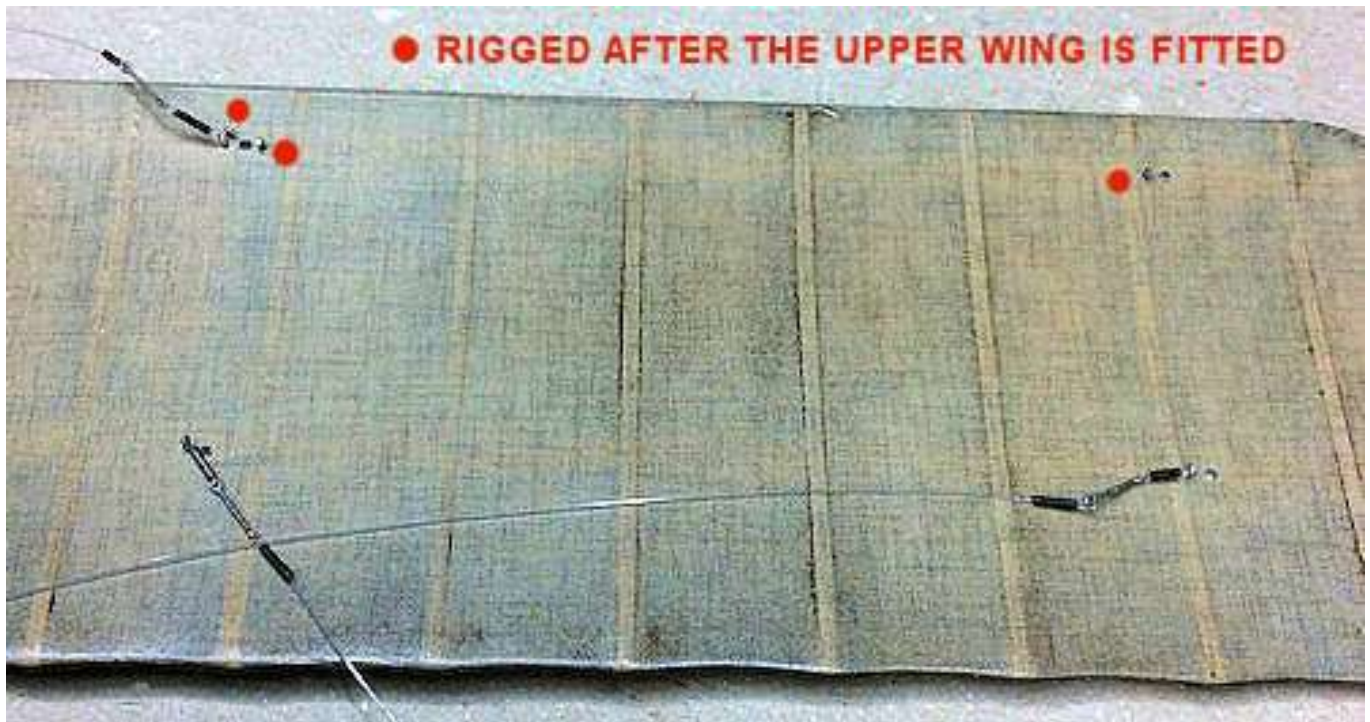

Lower wings:

NOTE: Make sure you fit the correct length of pre-rigged line to its correct anchor point.

Repeat the previous procedure to attach a pre-rigged turnbuckle line to the six anchors (3 each side) on the top surface of the lower wings, as shown of the following photograph.



Attached pre-rigged turnbuckle lines (upper wing not shown)

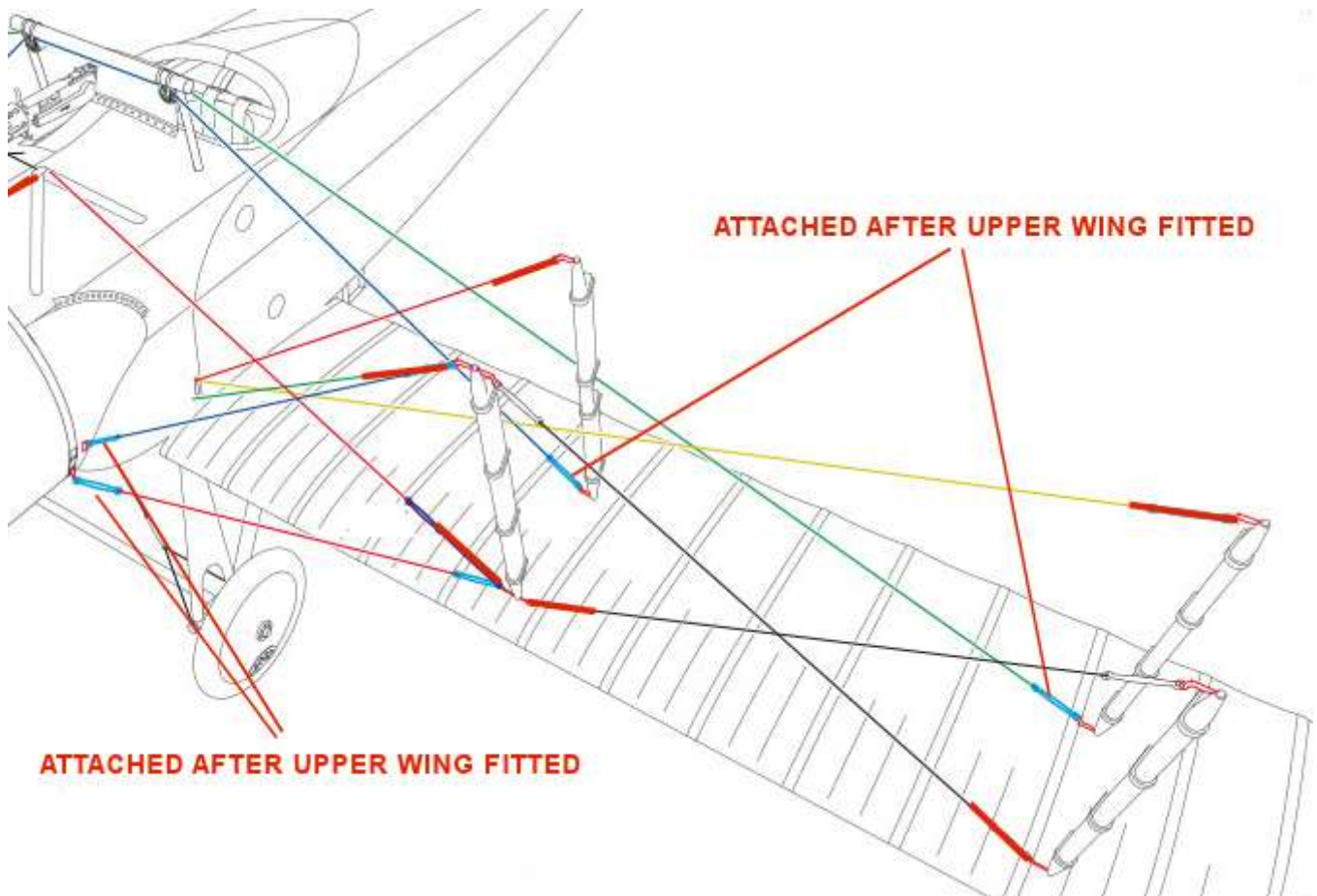

Upper wing - fit:

NOTE 1: *The interplane struts are fitted vertical, when viewed from the front, but angled forwards when viewed from the side.*

NOTE 2: *The fuselage cabane 'V' struts have no locating point on the underside of the upper wing, only on the fuselage. If they are fitted to the fuselage before the upper wing is fitted, it's uncertain whether they will be too tall and stop the wing from locating fully onto the interplane struts or be too short and not contact the upper wing. Therefore it's best to fit the cabane struts after the upper wing has been attached onto the eight interplane struts. In that way the fit of the struts can be ascertained and adjustments made if necessary.*

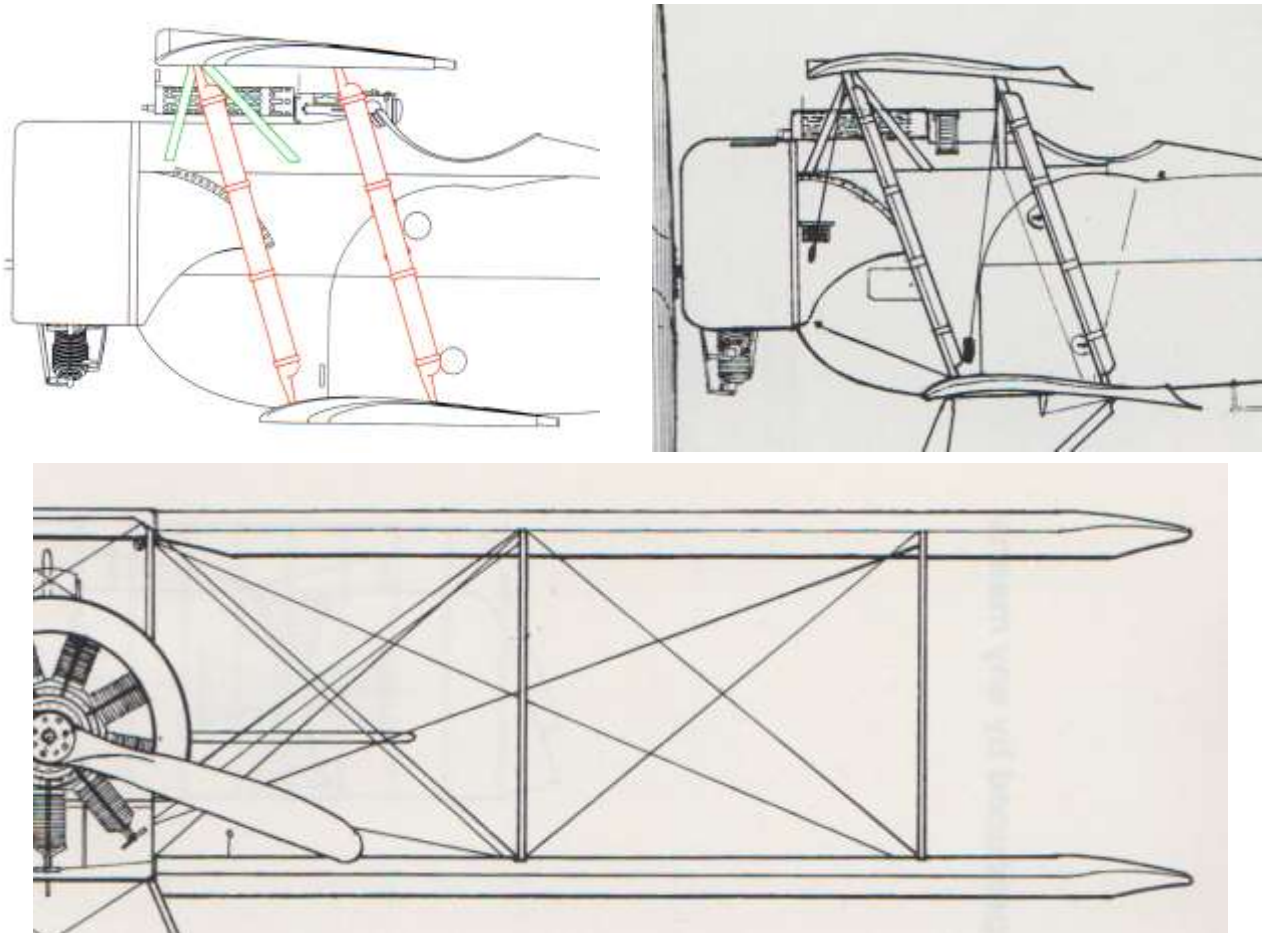

Make sure all primer and paint is removed from the ends of the interplane struts and their locating recesses in the underside of the upper wing and top surface of the lower wings.

Make sure all primer and paint is removed from the location recesses in the fuselage for the two cabane 'V' struts.

Make sure all primer and paint is removed from the locating ends of the two fuselage cabane 'V' struts.

Make sure the various pre-rigged lines are kept away from the interplane strut locating holes by using small pieces of de-tacked masking tape.

NOTE: *The two interplane struts with the central cut-out are at the rear, inboard locations of the wings.*

During the following step, make sure the interplane struts are vertical, when viewed from the front, correctly angled forwards when viewed from the side and are correctly spaced between the front and rear struts (to match the distance between the struts on the lower wings).

Dip the one end of each of the eight interplane struts into thin CA adhesive and secure them into the strut locating holes in the underside of the upper wing.

Position the lower wings of the fuselage assembly on a flat surface with support packing under the rear of the fuselage.

Carefully locate the interplane struts into their locating holes in the lower wings, Make sure all of the interplane struts are fully located into the lower wings.

NOTE: *During the next step, use suitable supports at the leading edge tips of the upper wing, to prevent the upper wing tipping too far forwards, to keep it central over the cockpit and to keep its trailing edge parallel to the lower wings trailing edges.*

The leading edge of the upper wing should be slightly forward from the front cabane 'V' struts locating recesses in the fuselage.

Check the position and alignment of the upper wing

Apply cement carefully to the base of each strut to secure them into the lower wing.

Once the cement at the struts has fully set, remove and upper wing supports and check that the wing is securely attached and correctly aligned.

NOTE: *When fitting the fuselage cabane 'V' struts, the shorter legs of the struts are the forward struts. The longer legs of the struts are the rear struts.*

Test fit the two fuselage cabane 'V' struts into their recesses in the fuselage. They should locate fully and their tops contact the underside of the upper wing, just outboard from the central recess in the wing.

Cement the fuselage cabane 'V' struts into their fuselage locating recesses. **Do not cement** the tops of the struts to the upper wing at this stage.

Once the cement at the cabane 'V' struts has fully set, secure the tops of the struts to the underside of the upper wing using thin CA adhesive. Make sure the adjacent anchor points are not contaminated with the adhesive.

Wings - final rigging:

WARNING: *The model should be handled carefully until the wings are fully rigged, which will provided additional strength and rigidity to the wings. Otherwise damage to or break away of any of the fitted struts is possible.*

Rig to anchor points:

NOTE: *Refer to the following illustration for these particular final rigging locations.*

Pass the free end of each fitted pre-rigged line (except the forward flying wires and drift wires) line through a blackened 0.5 mm diameter Brass tube, such as 'Albion Alloy's' MBT05 or similar.

Pass the lines through the 'eye' end of the relevant 'GasPatch' 1:48th scale Anchor Point.

Pass the lines back through the tube.

Keeping the line taut, move the tubes up to, but not touching' the 'eye' end of the anchor point.

Secure the tubes to the lines using thin CA adhesive.

Cut away the residual tags of line.

Trim each of the four wing warping control lines such that they can be inserted into the open slot in the bottom edge of the fuselage above the lower wing roots.

Apply CA adhesive to the top then bottom of the slots and keeping the lines taut, insert the one at a time into the slot and hold in position until the adhesive sets.

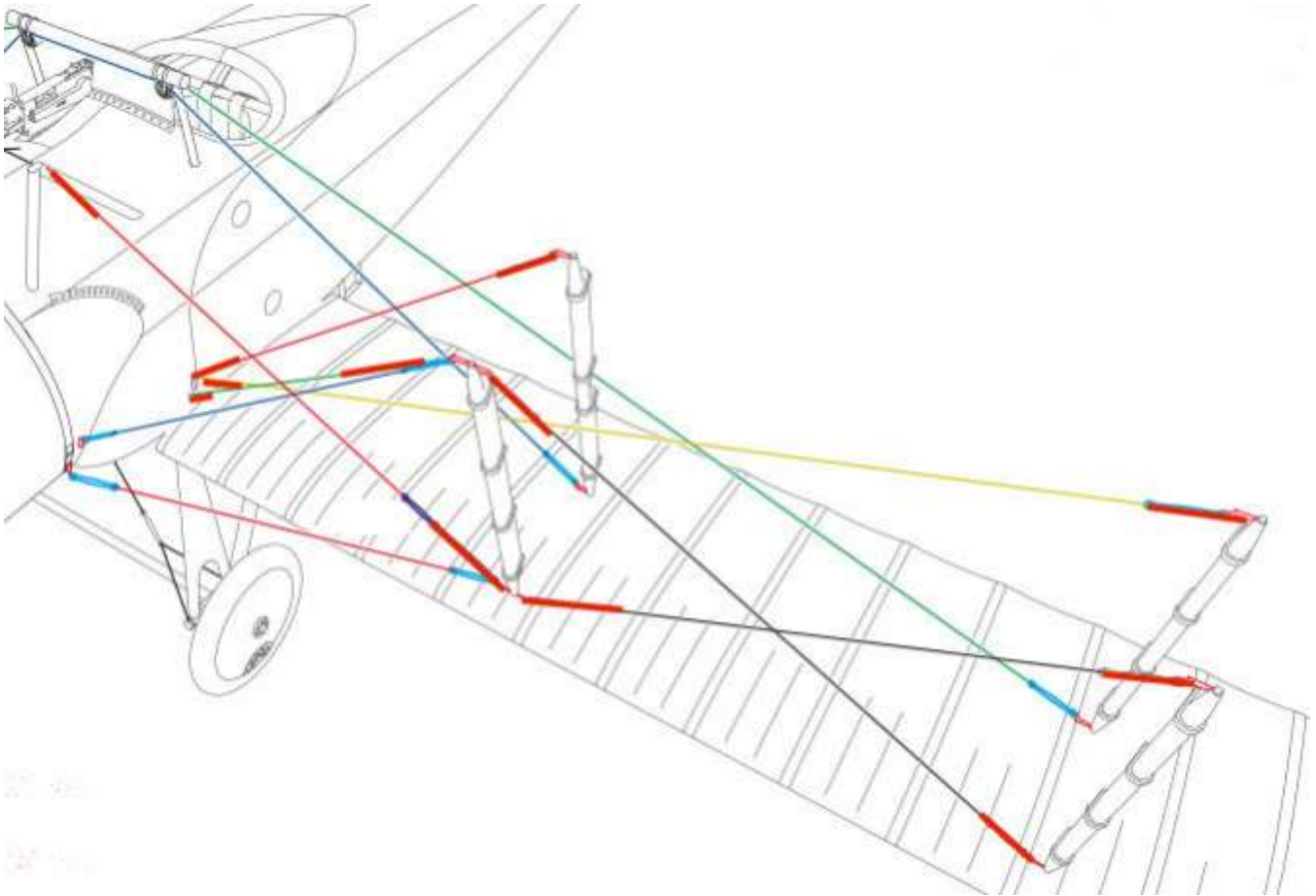

Wing warping control cables:

NOTE: *The wing warp reaction wires should have already been pre-rigged (with the ends of two of the lines secured with turnbuckles) and added to the pulley support frame.*

Test locate the pulley frame into its locating recesses in the fuselage sides. The frame should locate fully with the pulley cross bar within the upper wing centre cut-out and against the trailing edge of the wing. If necessary, sand or file the ends of the cross bar to achieve the correct fit.

NOTE: *The pulley cross bar will be secured against the upper wing after the control wires have been finally rigged.*

Locate the pulley frame into its locating recesses in the fuselage sides and cement them in position.

Cut a length of 'Stroft' 0.08 mm diameter mono-filament.

Pass the line through a short length of blackened 0.5 mm diameter tube, such as 'Albion Alloy's MBT05 or similar.

Pass a free end of the line through the 'eye' of the relevant 'GasPatch' anchor point on the top surface of the lower wing.

Pass the other end of the line through one of the securely attached 'GasPatch' Type C turnbuckles on one of the reaction wires.

Loop both ends of the 0.08 mm diameter mono-filament back through their end of the 0.5 mm diameter tube.

Pull the two ends of the 0.08 mm diameter line to draw it between the anchor point and the 'eye' of the turnbuckle.

Make sure the 0.5 mm tube is not too close to the anchor point.

Secure the tube to the lines at the anchor point end of the 0.5 mm diameter tube, using thin CA adhesive.

Carefully cut away the residual tags of 0.08 mm diameter line.

Repeat the procedure to attach the securely attached Type C turnbuckle on the other reaction wires to its anchor point on the top surface of the lower wing.

Repeat the procedure on the opposite ends of the two reaction wires on the loosely attached Type C turnbuckles at the opposite lower wing.

NOTE: *During the following steps, do not pull too hard on the two reaction wires, otherwise they may pull through and detach from the pulleys on the support frame.*

Keeping a reaction line taut, move its tube up to, but not touching' the 'eye' end of the relevant anchor point in the lower wing.

Secure the tube to the lines using thin CA adhesive.

Cut away the residual tags of line.

Repeat the procedure to attach the other reaction line to its anchor point.

Using thin CA adhesive, secure the pulley cross bar against the trailing edge of the upper wing centre section.

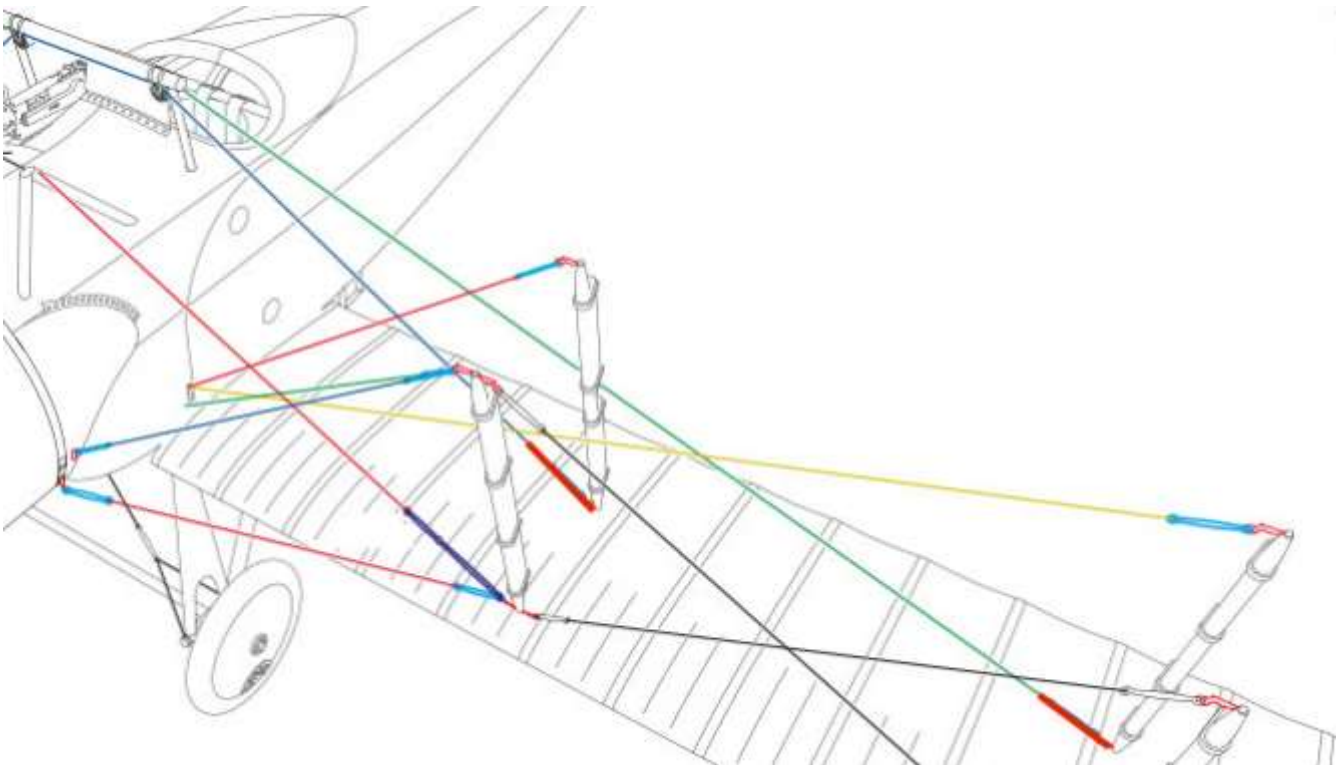

Cabane struts - bracing:

Trim the pre-rigged bracing wires for the fuselage cabane struts such that they can cross each other and be inserted into their relevant pre-drilled holes in the forward decking panel.

Insert the free ends of the bracing wires diagonally across each other and into their pre-drilled holes.

Keeping the lines taut, secure them in position using thin CA adhesive.

NOTE: *When the upper wing is fitted, the top of the eyes of the pilot figure are more or less aligned to the trailing edge of the upper wing, as can be seen in the following photographs.*



Drift wires:

Pass the free end of each pre-rigged drift wire line through a blackened 0.5 mm diameter Brass tube, such as 'Albion Alloy's' MBT05 or similar.

Pass the lines through the 'eye' end of the relevant 'GasPatch' 1:48th scale anchor point on the lower wings.

Pass the lines back through the tube.

Leave the loop of line slack at this stage.

Cut a length of 'Stroff' 0.08 mm diameter mono-filament.

Pass the line through a short length of blackened 0.5 mm diameter tube, such as 'Albion Alloy's' MBT05 or similar.

Pass a free end of the line through the 'eye' of the 'GasPatch' Type C turnbuckle on the drift wire.

Pass the line through the anchor point fitted to fuselage side below the engine cowl side panel.
Loop both ends of the 0.08 mm diameter mono-filament back through their end of the 0.5 mm diameter tube.

Pull the two ends of the 0.08 mm diameter line to draw the 0.5 mm tube between the anchor point and the 'eye' of the turnbuckle.

Make sure the 0.5 mm tube is not too close to the anchor point.

Secure the tube to the lines at the anchor point end of the 0.5 mm diameter tube, using thin CA adhesive.

Carefully cut away the residual tags of 0.08 mm diameter line.

Keeping the line taut, pull the exposed end of the line at the anchor point on the lower wing to draw the 0.5 mm tube up to, but not touching, the anchor point.

Make sure the 0.5 mm tube is not too close to the anchor point.

Secure the tube to the lines at the anchor point end of the 0.5 mm diameter tube, using thin CA adhesive.

Carefully cut away the residual tags of 0.08 mm diameter line.

Repeat the procedure to attach the opposite drift wire.

Forward flying wires:

Follow the previous procedure to attach the two forward flying wires, but with these differences:

The lines should have been pre-rigged with 'GasPatch' 1:48th scale 'One End' type turnbuckles.

Before securing in position, the tang of the turnbuckles should be carefully bent such that when fitted into the pre-drilled holes in the engine cowl side panels, the rigged lines aligns correctly to the anchor point in the upper wing.

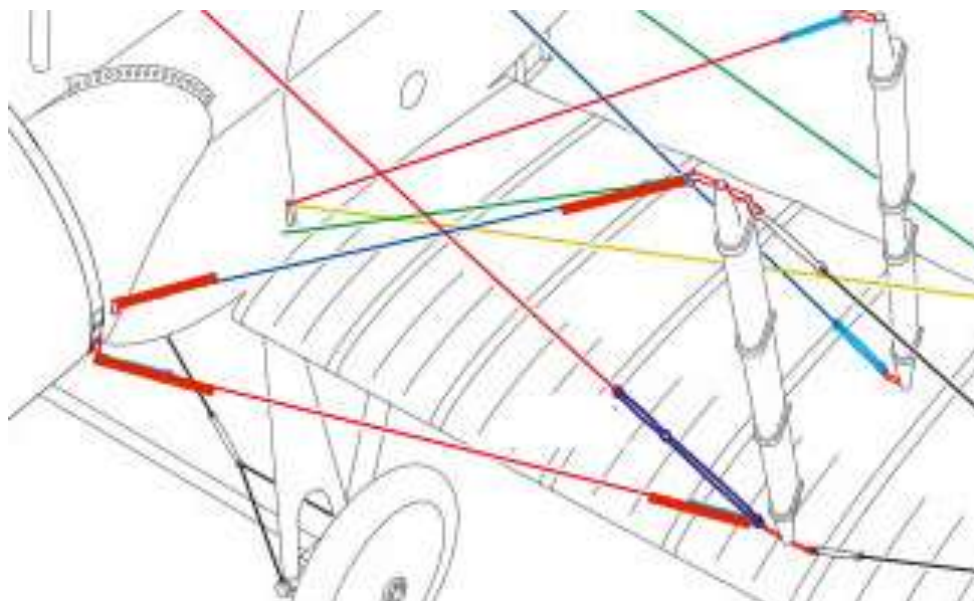

Turnbuckle - painting:

Carefully brush paint the centre section (barrel) of each turnbuckle with a mix of 'Mr. Colour' Copper (215) and Brass (219) or similar, to give a Bronze colour.

Tightening of rigged lines:

NOTE: *No-matter how careful you are to keep all installed rigging taut, there will be instances when after completing the rigging, one or more of the lines will be slack. This can be remedied by the careful application of heat close to and along the relevant line. Heat causes the mono-filament to shrink and therefore the line tightens.*

WARNING: *Apart from the obvious hazards associated with a heat source, care should also be taken not to apply too much heat, hesitate at one location along the line or touch the line. Otherwise the line will melt and snap. Also take care not to touch the model.*

If a rigging line requires tightening a suitable heat source will be required. I use a small electrical soldering iron.

Move the heat source close to and along the line watching for the line to shrink. Keep the heat source moving and avoid touching the line or the model.

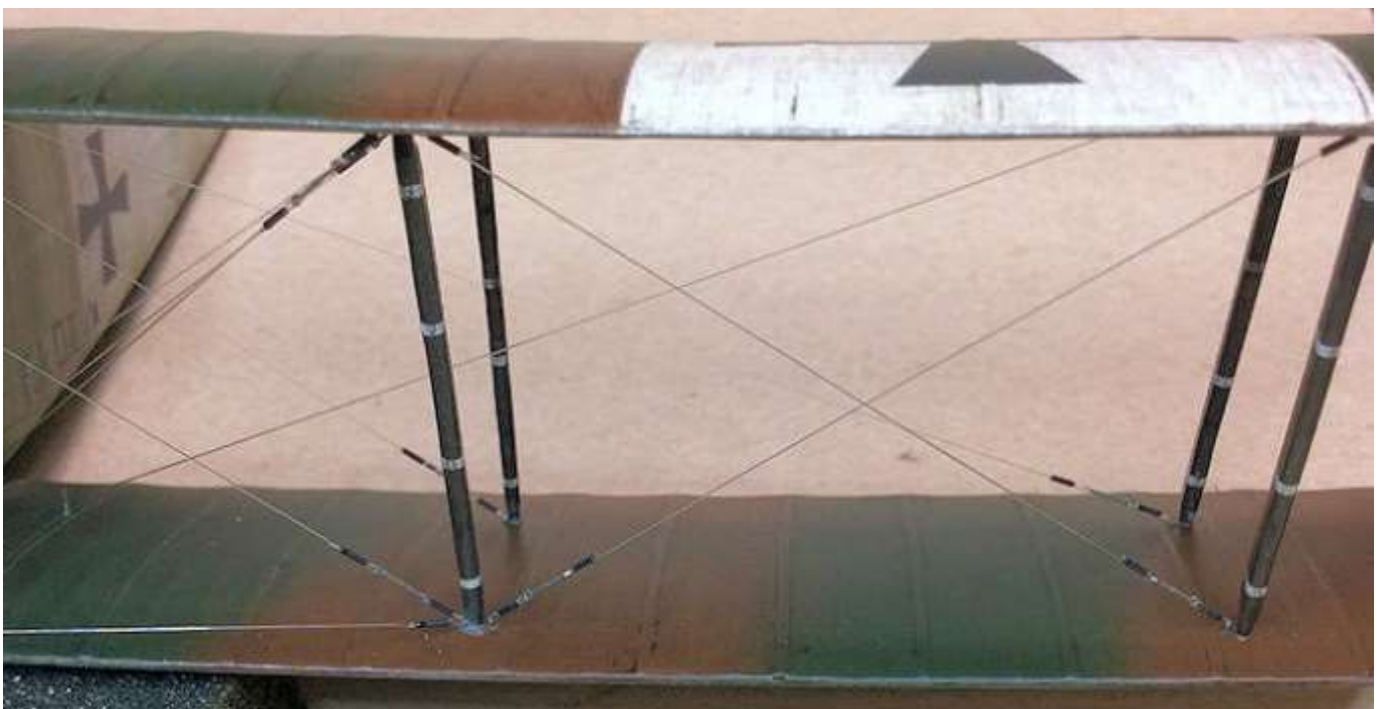

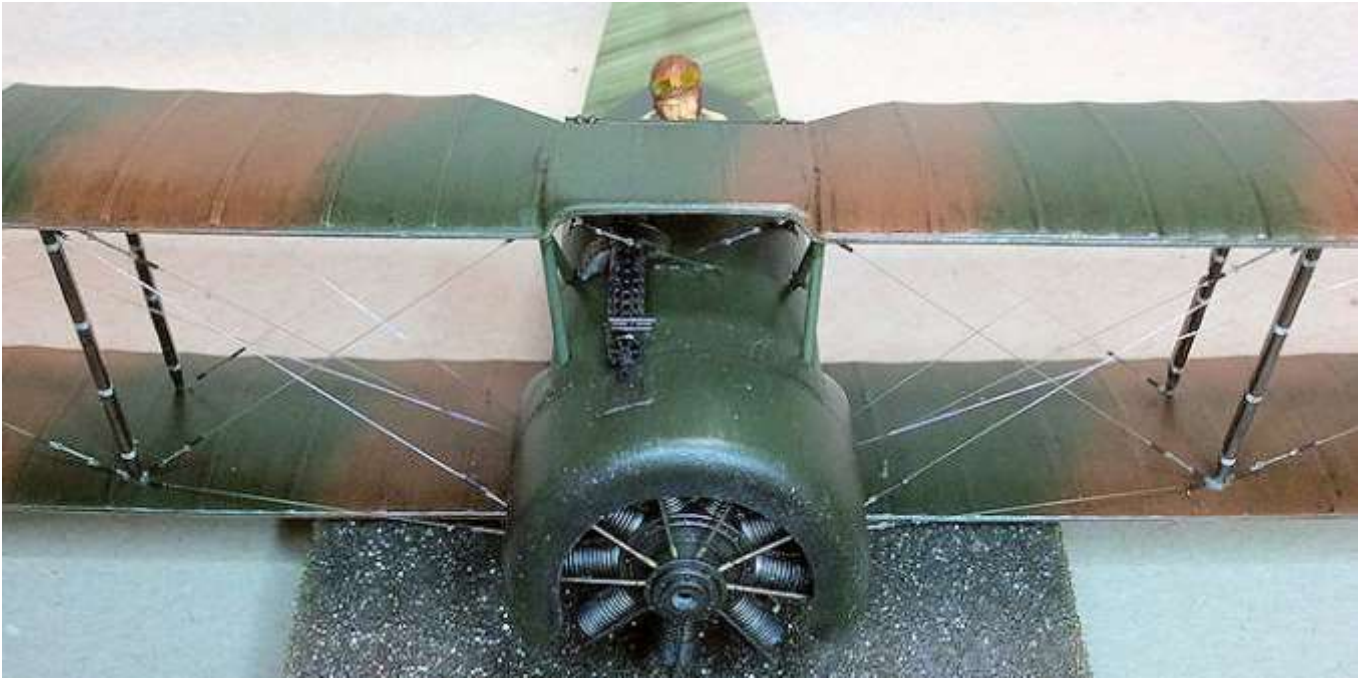

Landing gear:

Using thin CA adhesive, secure the fitted location rods in the landing gear assembly into their pre-drilled holes in the underside of the fuselage. Make sure the landing gear struts fully locate.

Using thin CA adhesive, secure a 'GasPatch' 1:48th scale anchor point into the two pre-drilled holes in the underside of the fuselage, inboard from the landing gear forward struts.

Pass the end of a pre-rigged line (Type C turnbuckle) through a 0.5 mm diameter blacked tube then through one of the fitted anchor points.

Loop the line back through the tube and leave the line loop slack.

Cut a length of 'Stroff' 0.12 mm diameter mono-filament or similar.

Loop one end around the **diagonally opposite** landing gear axle bar at the bottom, rear of the landing gear and secure it using thin CA adhesive.

Pass the free end of the line through a 0.4 mm diameter blacked tube, such as 'Albion Alloy's' MBT04 or similar.

Pass the line through the free 'eye' end of the turnbuckle.

Pass the line through another a 0.4 mm diameter blacked tube, such as 'Albion Alloy's' MBT04 or similar.

Loop the end of the line around the groove at the front of the landing gear axle bar at the bottom, front of the landing gear.

Pull on the exposed end tags of line at both the turnbuckle and the line loop at the front of the axle bar. The intention is to have both lines tight.

Using thin CA adhesive, secure the 0.5 mm diameter tube at the anchor point and the loop around the front of the axle bar.

Carefully cut away the residual line tags.

Repeat the procedure to attach the opposite landing gear bracing wire.

NOTE: *The landing gear suspension was formed by 'bungee' cord, which was wrapped separately around the front and rear of the axle bars. This suspension is not represented in the kit so needs to be created.*



Cut four long lengths of 'EZ' stretch line (heavy white).

Using thin CA adhesive, attach one end of each line to the bottom, front and rear of the landing gear axle bars.

Wrap each line several times through the opening at the bottom of the struts and around the opposite end of the other axle bar then back again around the first axle bar. Secure in position using thin CA adhesive.

Brush several coats of 'AK Interactive' Kerosene wash AK2039) over the 'EZ' line to darken the colour.



Tail skid:

Locate the created tail skid strut assembly into the four pre-drilled holes in the bottom, rear of the fuselage by securing the locating rods in the holes with thin CA adhesive.

If already fitted, remove the kit supplied 'bungee' cord that spans between the two forward struts. Leave the slot in the tail skid.

Locate the tail skid onto the support rod on the strut assembly.

Wrap 'MFH' black 0.4 mm flexible tube (P-961) around the two forward struts and over the slot in the tail skid, securing in place with thin CA adhesive.

Secure the tail skid to its support rod with thin CA adhesive.



Engine - fit:

Apply CA adhesive around the engine locating hole in the front of the fuselage or around the rear mounting cylinder of the engine.

NOTE: *During the next step, make sure the engine is positioned centrally on the face of the fuselage and within the cowl opening.*

Locate the assembled engine up into the underside opening of the engine cowl and into the fuselage locating hole.

Elevators - fit:

NOTE: *The elevator assembly should have already have locating rids added for inserting into pre-drilled holes in the rear end of the fuselage.*

Make sure the holes in the fuselage are free from primer, paint and decal.

Locate the elevator assembly onto the fuselage by inserting the locating rods into the pre-drilled holes.

Secure the elevator to the fuselage using CA adhesive.

Trim the length of the four pre-rigged elevator control line such that they can be inserted fully into the four elevator cable slots in the rear top and underside of the fuselage.

Make sure the four cable slots are open to accept the control cables.

Keeping the lines taut, secure each into its relevant cable slot, using thin CA adhesive.

Rudder - fit:

Make sure the two rudder cable slots in the rear, top of the fuselage are clear to accept the control cables.

Locate the rudder against the elevator cross bar with the bottom of the rudder post onto the tail skid strut assembly. If the rudder tilts back, file a slight groove into the front of the rudder post to enable it to fit over the elevator cross bar and therefore sit more vertically.

Secure the bottom of the rudder post to the tail skid strut using CA adhesive and against the elevator cross bar using cement.

Make sure the rudder is positioned vertically and aligned with the centre line of the fuselage.

Trim the length of the two pre-rigged rudder control line such that they can be inserted fully into the two rudder cable slots in the rear top of the fuselage.

Keeping the lines taut, secure each into its relevant cable slot, using thin CA adhesive.



Wheels - fit:

Cement the two wheels onto the ends of the axle, making sure the wheels are vertical when viewed from the front and aligned with the fuselage and parallel to each other when viewed from above.

Elevator control - under fuselage:

NOTE: *The elevator control lever and cable in the underside of the fuselage are not represented in the kit. The two slots in the underside of the fuselage should already have been created.*

I used a spare photo-etch double ended control horn, which I drilled through the centre using a 0.5 mm diameter drill.

I cut a short length of 0.4 mm diameter rod, such as 'Albion Alloy's' or similar, which was secured through the hole using thin CA adhesive.

I cut a length of 'Stroft' 0.08 mm diameter mono-filament.

I passed the line through a blackened 0.4 mm diameter tube, such as 'Albion Alloy's MBT04 or similar then through a hole on the end of the control horn.

I passed the line back through the 0.4 mm diameter tube.

I moved the 0.4 mm diameter tube up to, but not touching, the control.

Secure the tube to the lines at the end of the 0.4 mm diameter tube, using thin CA adhesive.

Carefully cut away the residual tags of 0.08 mm diameter line.

Insert the control lever into the forward slot created in the underside of the fuselage.

Position the control horn in-line with the centre line of the fuselage and with the added rod resting on the inside of the fuselage at each side of the centre line.

Secure the control horn and rods in position using thin CA adhesive.

Keeping the line taut, insert the free end of the line into the rear slot created in the underside of the fuselage.

Secure the line in the rear slot using thin CA adhesive.

Brush paint the control horn with 'Tamiya' Semi-Gloss Black (X18) or similar.

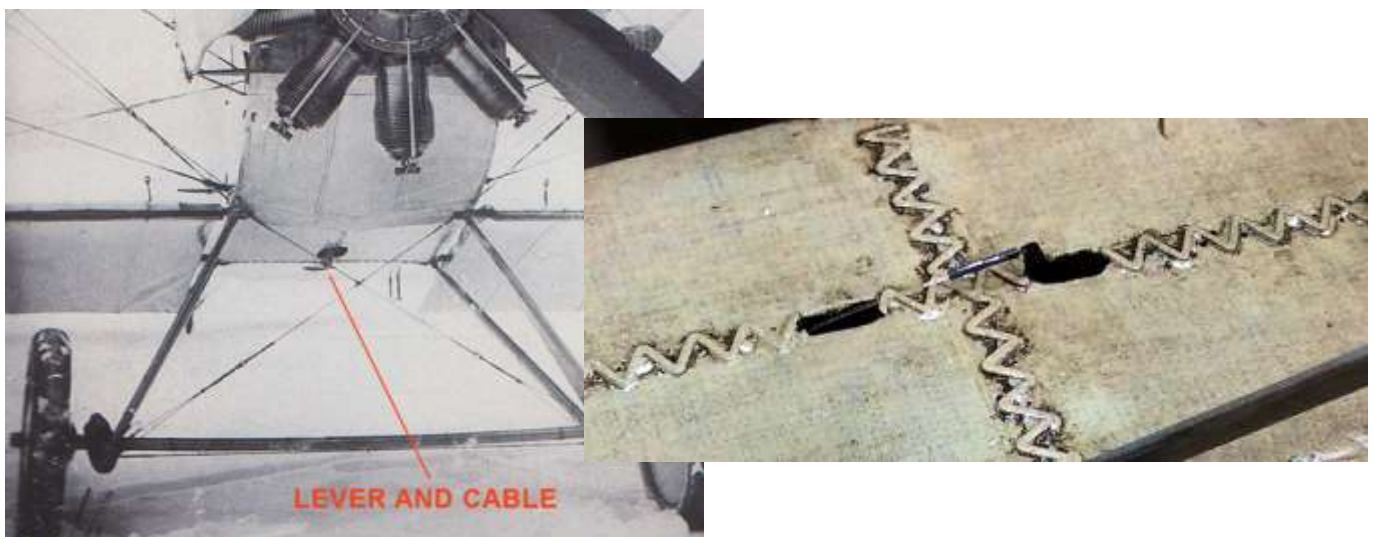

Pilot's foot step - fit:

Drill two holes of 0.8 mm diameter into the underside edge of the fuselage, on the left side just rear from the trailing edge of the lower wing. The holes should match the legs of the pilot's foot step.

Brush paint the pilot's foot step with 'Tamiya' Semi-Gloss Black (X18) or similar

Cement the pilot's foot step into the pre-drilled holes.

Propeller - fit:

NOTE: *The intention is to have two mechanic figures included in the final display with one priming the engine cylinders and the other hand turning the propeller to position the cylinders. As such, fitting of the propeller needs to be carried out using the figures to be able to position the propeller accurately.*

The propeller being fitted is a replacement for the kit supplied propeller

Place the aircraft on a flat surface with the propeller fitted but not secured in position.

NOTE: *Refer to Part 12 (Figures) of this build log for the mechanic figures 1 and 2.*

Position the two mechanic figures such that the propeller is being held by the mechanic 2 whilst mechanic 1 is working on the engine.

Note the position of the propeller.

Remove the propeller and apply either cement (if you're using the kit supplied propeller) or slow acting CA adhesive to the propeller shaft and re-locate it in the noted position. Alternatively leave the propeller a loose fit to allow it to be repositioned.



Windscreen - fit:

The windscreen supplied with the kit is just an acetate outline of the windscreen, which needs to be cut to shape. The biggest problem with the acetate windscreen is that it is too thin and flexible and therefore there is no way to easily secure it in position on the curved fuselage and at the same time conform it around the front of the cockpit. Also on this model in particular, there is very little space between the underside of the fitted upper wing and top of the fuselage, making locating the windscreen extremely difficult. Finally the shape of the kit windscreen is different to that seen on photographs taken at the time.



Given all of the above, I chose to not use the kit supplied acetate windscreen and instead, I used an appropriately shaped windscreen from my 'spares' box. The windscreen was secured in place using 'MicroScale' Kristal Klear PVA adhesive.

PART 12

FIGURES

PART 12 - FIGURES

The figures I chose to use are the 'Kellerkind Miniature' German engine crew (54101) and the 'Wings Cockpit' figures - seated LSK pilot (LSK 04A), sculpted by Steve Warrilow.

Pilot figure:

NOTE: The 'Wings Cockpit' figures - seated LSK pilot (LSK 04A), requires extensive modification in order for it to fit into the cockpit assembly, which was not designed to have a seated figure. The cockpit assembly (pre-painting) has been created in Part 10 (Fuselage) of this build log.

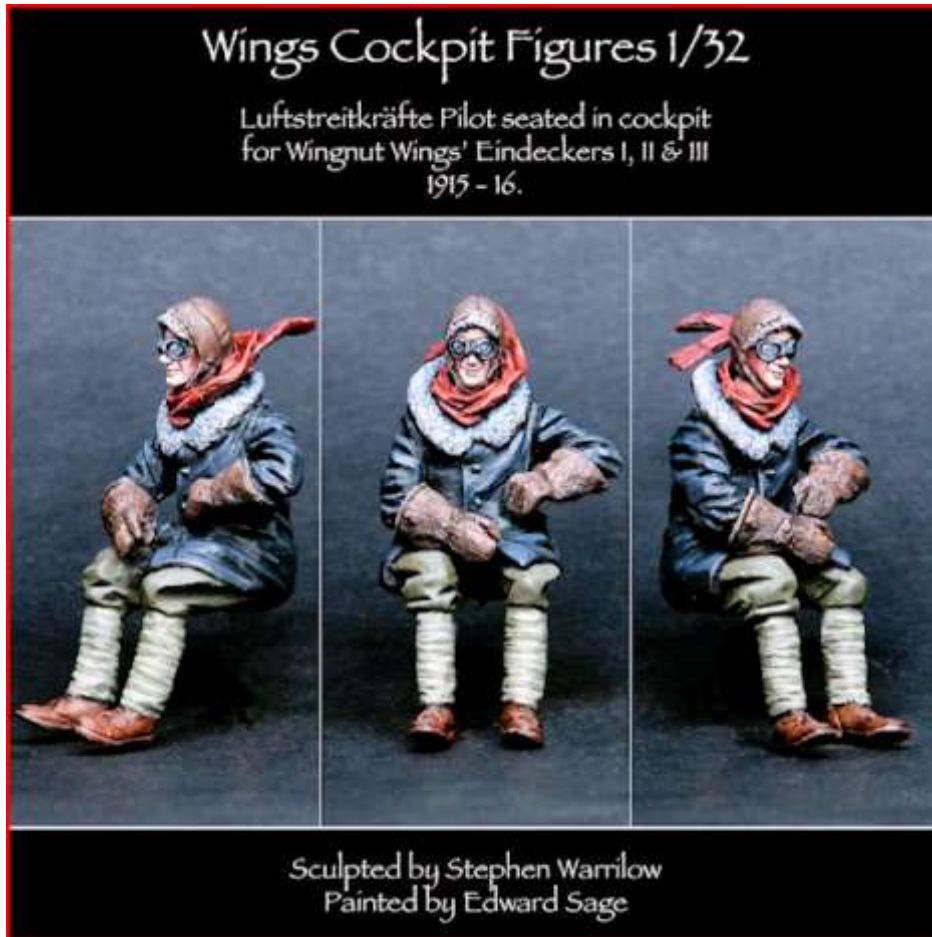

Scrape or sand away any mould imperfections or seams lines from the pilot figure, head and arms.

Carefully lower the pilots body into the seat in the cockpit assembly, but do not force it into the seat.

Note the areas on the figure where material needs to be removed to allow the figure to locate fully into the seat. I found that large areas of the bottom, lower back and outer edges of the figure needed to be removed. Also the pilot's feet, which will not be seen once the figure is installed, needed to be removed to clear the fitted rudder bar.

Scrape or sand away the necessary areas until the pilot can be lowered unobstructed into the seat.

Drill a hole of 0.6 mm diameter into the centre of the arm sockets in the pilots body.

Drill a hole of 0.6 mm diameter into the centre of the arm locating 'stubs'.

Cut short lengths of 0.5 mm diameter rod, such as that from 'Albion Alloy's'.

Secure the rods into the pre-drilled holes in the arms.

NOTE: *The following step will require several test fits of the body and right arm.*

Locate the right arm into the pilot's body the carefully position the body into the cockpit. Note how the arm needs to be angled to allow the body to fully locate in the seat with the hand of the right hand resting on the instrument.

Scrape or sand away the necessary areas of the right arm and body until the body can be lowered unobstructed into the seat with the arm correctly positioned.

Remove the body and secure the right arm to the body in the correct position, using a thicker, slow action CA adhesive.

Before the adhesive sets, reposition the body into the cockpit with the arm positioned and leave until the adhesive has set.

Repeat the procedure to add the left arm to the body. The left arm should be modified so when the body is located in the cockpit, the arm is resting on the side of the cockpit.

Once the adhesive securing the two arms gas fully set, fill any areas that have been modified, such as the arms sockets, with a modelling paste, such as 'Perfect Plastic Putty' or similar.

Once the putty has fully set, file or sand the repaired areas to blend them into the body.

Secure the pilot's head onto the body at the desired angle.

Remove the figure from the cockpit.



NOTE: *At this stage, the straps of the kit supplied photo-etch seat harness need to be fitted.*

Remove the four photo-etch seat straps from the kit supplied sheet and remove any residual photo-etch tags from their edges.

Anneal (soften) the four straps by applying heat from such as a cigarette lighter or similar. Move the heat source continuously along each strap until you see a colour change, then stop. Applying too much heat will melt the photo-etch.

Test fit the lap straps such that the triangular end fittings overlap each other in the centre of the pilot's body. If necessary, file or scrape away the figure to create a smooth 'belt line' around the body.

Secure one lap strap end fitting to the figure, using thin CA adhesive.

Secure the other lap strap end fitting onto the first, using thin CA adhesive.

Cut away the excess lap straps at the edge of the pilot's waist.

Secure both lap straps to the sides of the figure, using thin CA adhesive.

Cut the shoulder straps above the lap end fittings such that they can be located onto the figure with their cut ends at the body to collar join.

Secure both cut shoulder straps to the figure, using thin CA adhesive.

Cut two lengths of plain shoulder strap such that they can be located on the rear of the pilot's shoulders and just below the cockpit rim when the figure is fitted into the cockpit.

Secure both cut shoulder straps to the figure, using thin CA adhesive.



Temporarily fit the pilot onto the seat in the cockpit.

Make sure the figure fully locates into the cockpit and if necessary, make any adjustments to the figure to achieve this.

NOTE: *The decking insert (kit part A7) is not used for this particular build.*

Test fit the decking panel insert (kit part A8) in position and if necessary adjust the pilot's right hand, to allow the insert panel to be fitted correctly.

Test fit the machine gun into its opening in the cockpit decking and if necessary adjust the pilot's right hand or the opening to allow the machine gun to be fitted correctly.

Remove the pilot figure from the cockpit.

Painting:

NOTE: *The figure was painted primarily using "Tamiya" acrylic paints, thinned with 'Tamiya' X20A thinners.*

Airbrush the figure with a grey primer, such as 'AK Interactive' Grey (AK-758) or similar.

Trousers: Ocean Grey (XF82) and mixed with Rubber Black (XF85) highlights.

Jacket: Red Brown (XF64) with Hull Red (XF9) highlights.

Helmet: Hull Red (XF9) with 'Humbrol' Leather (62) highlights.

Gloves: Flat Earth (XF52) with Desert Yellow (XF59) highlights.

Collar: White (XF2) with Flat Earth (XF52) highlights.

Flesh: Flesh (XF15) and White (XF2) with 'AK Interactive' Light Flesh (AL3012) highlights.

Harness: Desert Yellow (XF59).

Goggles: Red Brown (XF64) with 'Humbrol' Leather (62) highlights.

Scarf: Light Blue (XF23).



Mechanic 1 (engine priming):

Assembly:

Cut away the moulding blocks from the figure and the two arms.

File or sand the underside of the two feet making sure the model can stand correctly without leaning.

Check fit the two arms into their locating recesses in the torso of the figure and adjust when necessary to achieve a good fit.

Using CA adhesive to secure the two arms onto the figure.

Use the figure to check the positioning of the propeller on the aircraft (refer to the last pages of Part 11 (Construction)).

Drill a hole of 0.9 mm diameter up through one of the legs. This will be used to fit a locating rod for holding during painting and for final locating onto the display base.

Using thin CA adhesive, secure a length of 0.8 mm diameter rod, such as a standard paper clip, into the pre-drilled hole in the leg of the figure.

Check the joints of the arms and file or sand, if necessary, to blend the arms with the body.

Painting:

NOTE: *The figure was painted using "Tamiya" acrylic paints, thinned with "Tamiya" X20A thinners.*

Airbrush the figure with a grey primer, such as 'AK Interactive' Grey (AK-758) or similar.

NOTE: *The figure was painted primarily using “Tamiya’ acrylic paints, thinned with ‘Tamiya’ X20A thinners.*

Airbrush the figure with a grey primer, such as ‘AK Interactive’ Grey (AK-758) or similar.

Trousers: Rubber Black (XF85) with mixed Ocean Grey (XF82) highlights.

Jacket: Rubber Black (XF85) with mixed Ocean Grey (XF82) highlights.

Jacket epaulets: Flat Brown (XF10).

Under jacket: Ocean Grey (XF82) mixed with Rubber Black (F85).

Hat: Ocean Grey (XF82) with Flat Red (XF7) trim.

Boots: Flat Brown (XF10).

Fuel primer: ‘Mr. Colour’ Stainless Steel (213).

Rag: Deck Tan (XF55).

Flesh - ‘AK Interactive’ Light Flesh (AK3012) with ‘Model Colour’ Light Flesh (70.928) highlights.

Hair - ‘Tamiya’ Flat Earth (XF52).

Metal fittings - ‘Mr. Colour’ stainless Steel (213).

Surface finish:

Boots - ‘Tamiya’ Weathering Master Set A (Mud).

Trousers - ‘Tamiya’ Weathering Master Set D (Oil Stain).



Mechanic 2 (propeller turning):

Assembly:

Cut away the moulding blocks from the figure and the two arms.

Assemble the figure as for Mechanic 1.

Painting:

NOTE: *The figure was painted using ‘Tamiya’ acrylic paints, thinned with ‘Tamiya’ X20A thinners.*

Airbrush the figure with a grey primer, such as ‘AK Interactive’ Grey (AK-758) or similar.

Trousers: Rubber Black (XF85) with mixed Ocean Grey (XF82) highlights.

Jacket: Rubber Black (XF85) with mixed Ocean Grey (XF82) highlights.

Jacket epaulets: Ocean Grey (XF82).

Hat: Ocean Grey (XF82) with Flat Red (XF7) trim.

Boots: Flat Brown (XF10).

Flesh - ‘AK Interactive’ Light Flesh (AK3012) with ‘Model Colour’ Light Flesh (70.928) highlights.

Hair - Rubber Black (XF85).

Metal fittings - ‘Mr. Colour’ stainless Steel (213).

Surface finish:

Boots - ‘Tamiya’ Weathering Master Set A (Mud).

Trousers - ‘Tamiya’ Weathering Master Set D (Oil Stain).



PART 13

DISPLAY BASE

PART 13 - DISPLAY BASE

The display case is made from two sheets of 3mm thick Piano Black Acrylic sheet cemented together with a transparent top fabricated from 3mm thick Clear Acrylic sheet. This was custom made for me by Paul Moss at 'Inperspective' (Ebay). The name plaque was also made by an on-line retailer 'The Engraving Shop'.

The grass mat was cut to shape from a sheet of 'Polak' grass mat (Wild Meadow variation C 4703). The cut mat was then positioned on the base and the model and figure test placed to achieve the best effect and to make sure the transparent cover of the case would be able to be located without touching the model. The model and figures were then removed with the grass mat left in position on the display base. The edges of the grass mat were then carefully lifted and a soft marker pen was used to mark the outline of the grass mat, but approximately 5 mm inside the mat edge. The grass mat was then removed and the area of the display base inside the marks was scuffed using a coarse grit sand paper, in order to give a key for the adhesive.

NOTE: *When applying the adhesive, make sure it is not applied too thickly and close to the edges of the finally positioned grass mat. Otherwise the adhesive may be squeezed out from under the grass mat once weight is applied to hold down the mat during setting of the adhesive.*

A coat of PVA adhesive (white glue) was applied to the scuffed area on the display base and to the back of the grass mat. The grass mat was then laid onto the PVA adhesive and positioned correctly. Light pressure was applied to ensure the mat was in contact with the adhesive.

Finally an acrylic plaque stand was positioned to the left, front corner of the display base (just in from the edges of the shoulder for locating the transparent acrylic cover. The area on the underside of the stand and its contact are on the display base were scuffed using a coarse grit sand paper, in order to give a key for the adhesive. A thin coat of contact adhesive was then applied to both scuffed areas and once the adhesive started to set, the stand was carefully position onto the display base and pressed down to make full contact. The self-adhesive backed information plaque was the positioned onto the stand and pressed to make full contact.

The model and figures were then positioned on the base in their final positions and the support pins in the figures leg marked into the grass mat. Holes of 1.0 mm diameter were then drilled through the grass mat and into, but not through, the base. The holes were cleared of residual acrylic to ensure the pin in the figures would fully locate. The figures were then test fitted and where necessary, the support pin was snipped to the required length to fully locate into the display base.

NOTE: *The aircraft model is not secured to the display base as this can cause shock damage to the model if the display is transported to shows etc. For that the aircraft model would be packed separately for transporting.*

Thin CA adhesive or PVA adhesive was then applied to the support pins of the figures, which were then located, in the desired positions, into their pre-drilled location hole. The aircraft itself, being light in weight, will tend to sit on top of the grass on the mat, rather than seat fully down, as would a real aircraft. Therefore the location of the aircraft wheels and tail skid were marked onto the grass mat and those areas scrapped through the mat to create slight and unobstructed troughs, into which the aircraft could be located.

PART 14
COMPLETED
MODEL
PHOTOGRAPHS

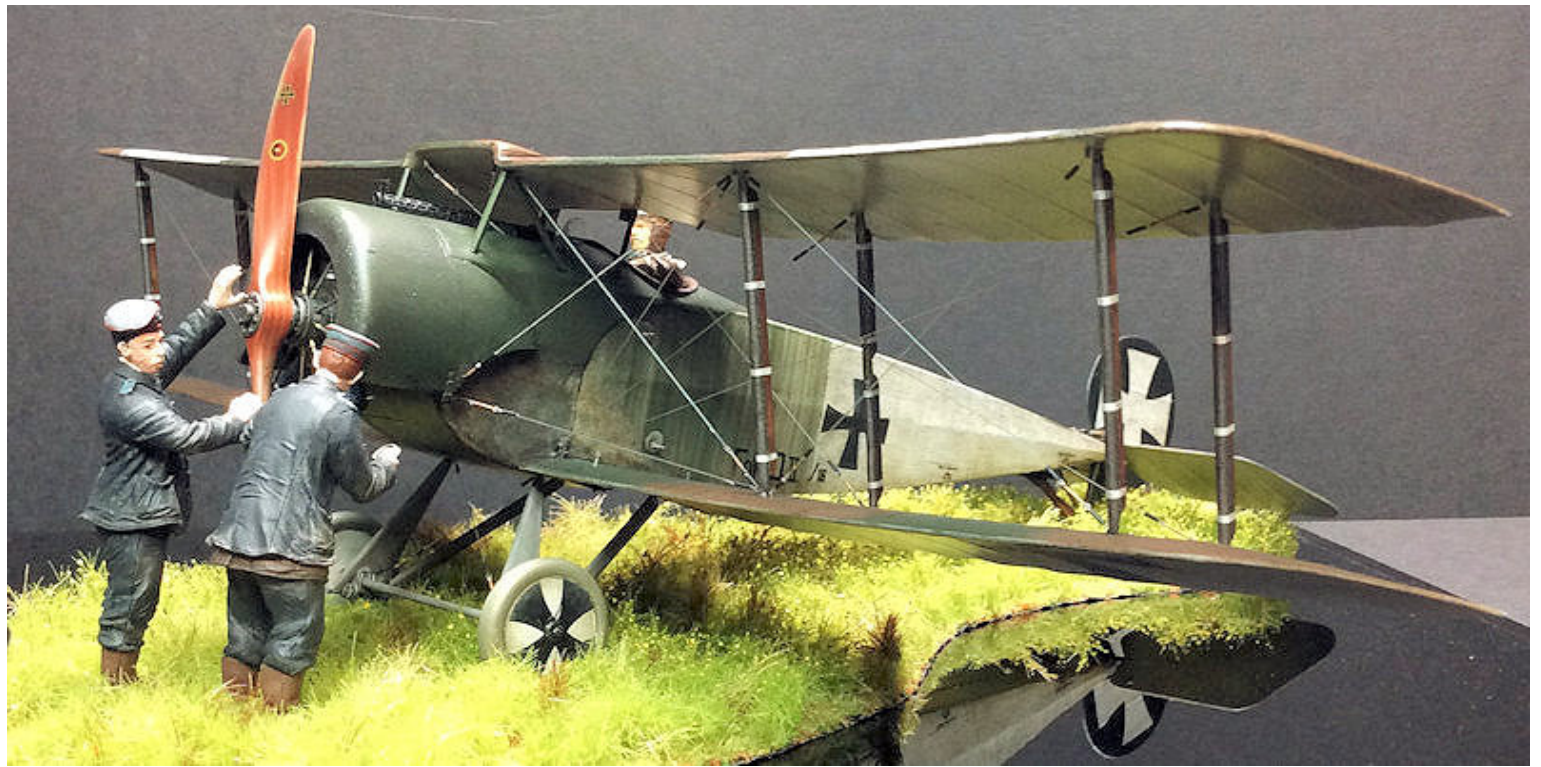



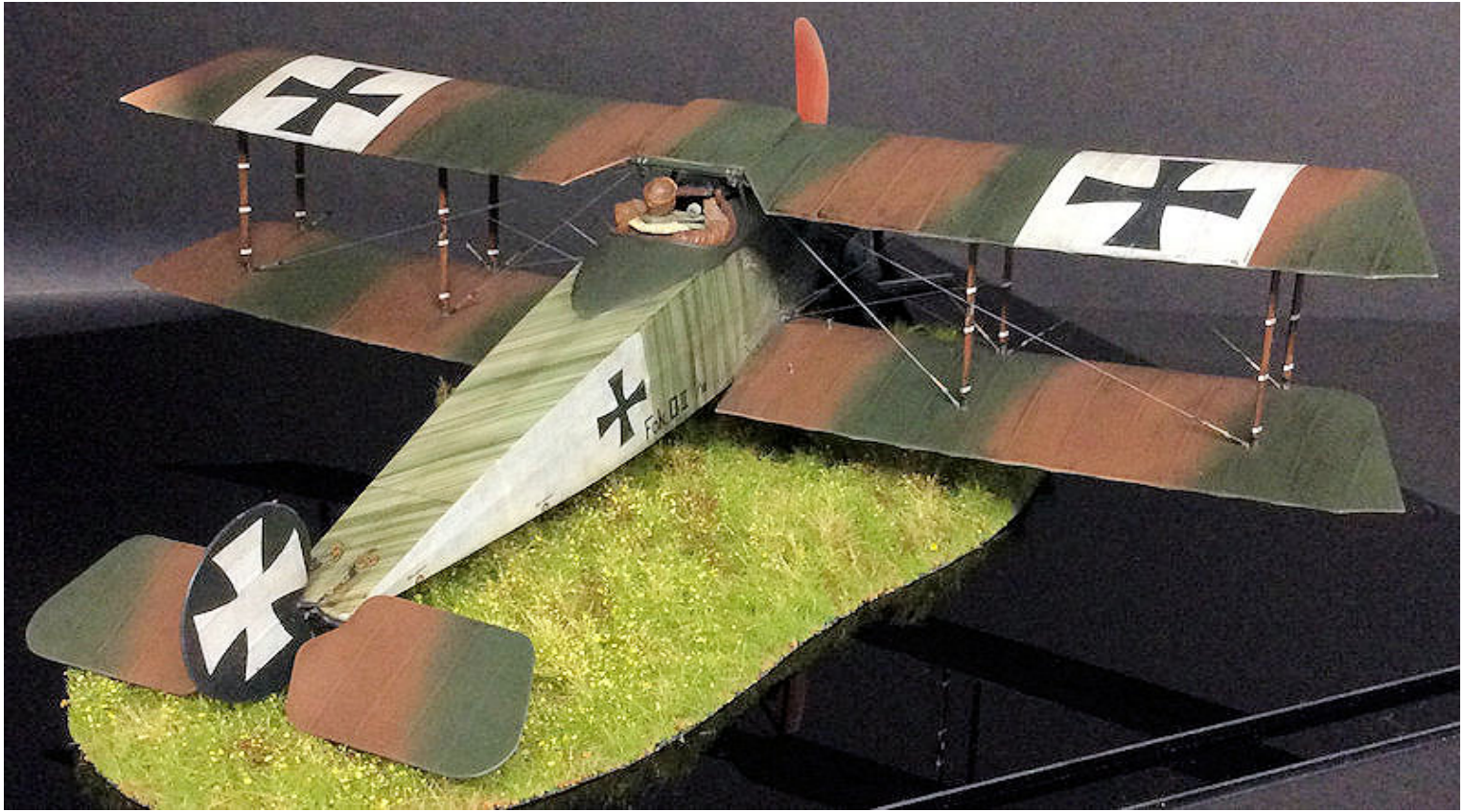







END