



World War One Aircraft Models

I have always held a fascination with early military aircraft. After serving for 27 years in the Royal Air Force, I became a Military Aerospace Technical Author. Like many modelers, I got involved in the world of construction kits at an early age, but stopped for most of my service career and for some years afterwards.

I started aircraft modeling again in 2015 and now enjoy the challenge of building aircraft of World War One. Since posting photographs of my completed models online, I been asked if I would create 'build logs' for my model builds.

Although I'm not a 'master' of this hobby, I do hope to be able to pass on what I have learned. As such, here is my build log, which covers my build of the 'Wingnut Wings' 1:32 scale model of the Bristol F.2b.

Mike 'Sandbagger' Norris

<https://mikesww1aircraftmodels.com>

mike.norris@mikesww1aircraftmodels.com

Completed: October 2023

CONTENTS

INTRODUCTION

AFTER MARKET

PART 1 - THE MODEL KIT

PART 2 - THE AIRCRAFT

PART 3 - WOOD EFFECTS

PART 4 - WEATHERING

PART 5. DECALS

PART 6 - RIGGING (GENERAL)

PART 7 - BASIC ENGINE

PART 8 - PROPELLER

PART 9 - FUSELAGE

PART 10 - WEAPONS

PART 11 - CONSTRUCTION

PART 12 - PREPARATION FOR EXTERNAL RIGGING

PART 13 - CONSTRUCTION (CONTINUED)

PART 14 - FIGURES

PART 15 - DISPLAY BASE

PART 16 - COMPLETED MODEL PHOTOGRAPHS

INTRODUCTION

Before I start with the build log, I'd like to show how I've set up my work area. I prefer to keep the work area as clear as I can (I've lost too many small items in the past). I think it's important to have the tools etc you need ready to hand and other, non-essential stuff tucked out of the way until needed. I'm lucky in that I have my 'man cave', which is sorted into a modelling area, airbrush spray booth in addition to my work station PC, games PC and games console.



AFTER MARKET

Figures

'Kellerkind' RFC mechanic middle East (54/107),
'Copper State Models' Aussie Digger (F32-052),
'Master Box' Camel and rider from box set (MB3564).

After Market Parts

'Proper Plane' Bristol wood propeller and 'REXx' exhaust (PR-036-32015),
'Gaspatch' British wicker seat (tall) (22-32249).

Decals

'Aviattic' Bleached Clear Doped Linen (ATT32044),
'Aviattic' Off White Linen (ATT32241),
'Aviattic' PC10 Medium Linen (ATT32090),
'Xtradecal' White parallel stripes (XPX2),
Microscale's 'MicroSet/Sol' setting solutions.

Rigging accessories

'GasPatch' Elite Accessories resin British late turnbuckles (1:48th scale),
'GasPatch' Elite Accessories metal turnbuckles Type C (1:48th scale),
'Steelon' or 'Stroft GTM' Mono-Filament 0.08 and 0.12 mm diameter,
'MFH' 0.4 mm diameter Clear (P-957),
'YLI' silk thread #100 (232 or 225).

Sundries (as required)

Paints ('Tamiya' Acrylic, 'Humbrol' Acrylic, Mr Metal Colour, 'Hataka' lacquers,
'Alclad' lacquers, 'AK Interactive' acrylic, 'AK Interactive' Primer and micro-filler
(Grey AK758 or White (AK759), 'Hataka' orange top lacquer,
'MFH' 0.4 mm diameter Black colour tube (P-961),
'Tamiya' X20A thinners, 'Mr. Colour' Levelling Thinners, PVA Adhesive,
'Fleky 5' CA thin adhesive, 'Flory Models sanding or Polishing sticks,
'PlusModel' lead wires, 'UHU' White Tack, 'Deluxe Materials' Perfect Plastic Putty,
'Alclad' Aqua Gloss 600 or 'Ammo' Aqua Gloss Clear (A.MIG-2503),
'Mr. Hobby' Mr. Surfacer 500 or 1000, 'Microscale' Micro Kristal Clear,
'Mr. Colour' self levelling thinner 400, 'AK Interactive' weathering pencils,
'Albion Alloy' micro-tube and rod (various diameters).

Weathering mediums (as required)

'Flory Models' clay washes and pigments, 'Tamiya' Weathering Master sets',
'Abteilung 502' smoke oil paint (ABT005),
White Spirits or 'AMMO Mig' enamel odourless thinners (A.Mig-2019),
'AK Interactive' weathering pencils, 'AK Interactive' Kerosene wash (AK2039).

Display Base

Purpose built Acrylic base and cover, etched plaque (information plate),
'Javis' Desert Zone Battle landscape mat (BZ3M),
A3 foam board 5mm thick, 'Sharpie' Black permanent marker (W10).

PART 1

THE MODEL

PART 1 - THE MODEL
(Wingnut Wings Kit No.32004)

This particular model kit was released by Wingnut Wings as an earlier wartime (32004) or late post war (32060) version.

As expected, any model from WingNut Wings (WNW) is at the top of quality and accuracy. The parts are manufactured from traditional 'plastic', not resin. There is minimal mould flash that needs to be removed and also virtually no ejection pin marks that need to be filled and sanded away. All of the main sprues, including the transparencies and photo-etch (PE) parts, are sealed in separate plastic bags, which prevents and sprue damaging another. There are seven main sprues, one transparency and one photo-etch sheet for this model. There are parts supplied in the kit that are not required for this model. The decal sheet supplied are by 'Cartograf' so should be of the best quality in both colour and registration. The decal sheet covers five individual aircraft. However some modellers have experienced problems with the decals supplied in some 'Wingnut Wings' released kits, finding they can crack or break up when being applied. Therefore, care should be taken during application of the decals. The instruction manual is in the well known format that WNW produce and has clear and concise instructions, including coloured illustrations and photos for reference. Also the manual has a lot of information on the aircraft including a colour profiles of the various aircraft colour schemes.

Independent reviews of this model kit can be found at the following URLs:

1. Hyperscale

https://www.hyperscale.com/2009/reviews/kits/wingnutwing32004reviewrb_1.htm

2. Aeroscale

<https://archive.aeroscale.net/review/4132>

**A description of the particular aircraft being modelled can be found in the following
Part 2 (The Aircraft).**

NOTE: *The model being represented served with No.111 Squadron, RFC in Palestine. This unit operated its aircraft primarily as fighters, restricting enemy reconnaissance flights and engaging German fighters over Suez. The following parts of the models will not be required for this particular model build, including those parts that will be replaced with aftermarket parts:*

Landing gear struts (A8 and A9)

Holt flares (C2 and D11)

Bomb racks (D1)

Cooper bombs (D5 and B10)

Bomb decals (43 and 44)

Closed radiator shutters (A35)

Propeller spinners (A28 and A29)

Propellers (B11 and B14)

Propeller back plate (A5)

Pilots seat and cushion (A20, A26 and A37)

Coolant pipe (A53) (can't be seen).

PART 2

THE AIRCRAFT

PART 2 - THE AIRCRAFT

This model represents Bristol F.2b, Serial No. A7194 when operating with No.111 Squadron (RFC), Deir-el-Belah, Palestine during 1917.

References:

Windsock Data File No.115 - Bristol Fighter (L.A. Rogers)
Windsock Data File No.4 - Bristol Fighter (J.M Bruce)
Windsock Data File Special No.1 - Bristol Fighter (J.M Bruce)
Windsock Data File Special No.2 - Bristol Fighter (J.M Bruce)
Profile Publications No.21 - Bristol Fighter
Schiffer Military History Book - British Aviation Squadron Markings WW1 (L.A Rogers)
Wingnut Wings kit instruction manual
Fetubi Books - The Sky their Battle Field II (Trevor Henshaw)
The Official History of Australia in the War of 1914-1918 (Vol 8 the AFC) - (F.M Cutlack 1933)
Australian War Memorial web site - <https://www.awm.gov.au/collection/B01646>

Adapted from the 'Wingnut Wings' manual

Initially conceived in early 1916 as the Bristol R.2a reconnaissance aircraft to replace the RFC's aging BE2 series, Frank Barnwell's design evolved into the Bristol Fighter in July 1916 following the incorporation of the brand new Rolls Royce 190hp 'Falcon' engine. An order was placed for 50 aircraft and the first production Bristol F.2a Fighter (A3303) made the types maiden flight on 9 September 1916.

Deliveries of this new aircraft to No.48 Squadron RFC started in December 1916 and continued through to March 1917 at which time they flew their 18 new Bristol F.2a Fighters to France. Their operational debut on 5 April 1917 was somewhat less than successful. Despite having the Bristol Fighter on strength for 3 months No.48 Squadron thought it to be structurally unsound and despite its name, flew them in a rather sedately manner similar to two seat reconnaissance aircraft, slow and steady as a platform for the rear gunner.

Not surprisingly they were shot down just like slow and steady reconnaissance aircraft. It was soon realized that Bristol's fighter was actually a very sturdy aircraft that could and should be maneuvered as if it were a single seat fighter with rear protection. A fighter it was, with over 240 pilots and gunners achieving ace status in the type before the end of the Great War. Further refinements to the design, of which the most obvious was angling the front longerons downwards to improve pilot visibility, resulted in the F.2b appearing in April 1917.

Several different engine types, including 150-200hp Hispano Suiza and Sunbeam's 200hp Arab, were fitted to the 'Biff' of 'Brisfit', as it became known, but by far the most common and successful were the 190-275hp V12 Rolls Royce 'Falcon'.

The Bristol Fighter continued to serve long after the war with many different air forces and was not finally withdrawn from Commonwealth service until it was retired by the RNZAF in 1936.

The basic aircraft statistics are:

Wingspan - 39' 3" (11.96m)

Length - 25' 9" (7.85m)

Maximum weight - 2800lbs (1070kg)

Maximum speed - 113mph (182kph)

Engine - Rolls Royce V12 'Falcon' 1 (190hp), 2 (220hp) and 3 (275hp)

Weapon (observer) - One or two Lewis .303" machine guns mounted on a 'Scarff' ring

Weapons (pilot) - One 0.303 Vickers machine gun

Bombs - 25 and 112lb bombs (maximum of 300lbs).

No.111 Squadron (RFC):

No.111 Squadron (RFC) was formed on the 1st of August 1917 at Deir-el-Belah, Palestine and was commanded by Major Shekleton. The Squadron was formed from aircraft of No.14 Squadron (RFC) and operated as a single seat fighter unit.

Initially it had a mixture of aircraft, such as the Bristol M1c, Airco DH2, Vickers FB19, Nieuport scouts and Bristol fighters. Eventually the Squadron was finally equipped in 1918 with the SE5a single seat fighter.

As the first Squadron in theatre, its mission was to restrict enemy reconnaissance flights and challenge the German fighter presence over Suez, which included on occasion acting as escorts to the aircraft of No.1 Squadron (AFC - Australian Flying Corps). The first Bristol F.2b aircraft were delivered in September 1917 and one of these claimed the first aerial victory for the Squadron on the 8th of October. The squadron began to receive the Royal Aircraft Factory S.E.5a in October 1917 and was fully equipped with the type during 1918 to wars end. During October saw a change of command when Major Shekleton was replaced by Major Strent as Major Shekleton became Commander of the 40th (Army) Wing. By December 1917, No.111 Squadron was based at Julis. Bristol F.2b, Serial No. A-7194 was built by 'Avro & Co' of Manchester and was delivered (along with A-7190 and A-7198) on the 25th of August 1917.

Pilot:

Arthur Hicks Peck was commissioned as a temporary (wartime only) second lieutenant in the British Army on the 7th of December 1914 and served in the Devonshire Regiment in France and Salonika. He eventually joined the RFC, being transferred to the General List and appointed a flying officer on the 4th of October 1916. He was appointed a flight commander with the temporary rank of captain on the 23rd of June 1917 and served in No.111 Squadron (RFC) based in Palestine. Flying a Bristol F.2 two-seater Peck scored three aerial victories with John Lloyd Williams acting as his observer/gunner. Peck was recommended for a Military Cross, following an action on the 29th of October 1917, when he single-handedly drove off three enemy reconnaissance aircraft over the Gaza Front. Eventually the squadron were re-equipped with the S.E.5a single-seat fighter and on the 4th of December he drove down an Albatros D.III out of control over Junction Station. Peck's award of the Military Cross was gazetted on 18 January 1918. On the 3rd of March 1918, he and Major F. W. Stent shared in the destruction of a Type C reconnaissance aircraft south-east of Yehudieh, which was Peck's fifth victory, earning him the status of 'ace'. The next day, the 4th of March, he was awarded the Distinguished Service Order. Finally, on the 23rd of March, Peck drove down out of control a Type C and two Albatros D.III's north of Jericho, an action which earned him a Bar to his Military Cross. On the 13th of April Peck was promoted to temporary major. He continued serving in the RAF until 1944. He died on the 14th of February 1975, aged 85.

Observer:

John Lloyd Williams was commissioned as a second lieutenant in the Denbighshire Hussars, a Yeomanry cavalry unit of the Territorial Force, on 17 July 1913. On the outbreak of war the 1st Battalion, Denbighshire Hussars, were mobilized as part of the Welsh Border Mounted Brigade. In November 1915 they were converted to infantry and in March 1916 were sent to Egypt to form part of the 4th Dismounted Brigade. In August 1917 Lloyd Williams was attached to No.111 Squadron (RFC) in Palestine, serving as an observer/gunner in Bristol F.2b fighters. Between the 8th of October and the 8th of November 1917, he was credited with three enemy aircraft destroyed and two captured, two with pilot Second Lieutenant R. C. Steele and three with Captain Arthur Peck. Lloyd Williams then trained as a pilot, being appointed a flying officer on the 30th of March 1918. He was awarded the Military Cross on 17 December 1917, which was gazetted on 19 April 1918. He continued flying in the RAF and was retired in 1934. The date of his death is not recorded.

Known victories of A7194 when operating in No.111 Squadron (RFC) during 1917.

Date/Time	Serial No.	Opponent	Result	Location	Pilot	Observer
8th Oct 17	Bristol F.2b A7194	Albatros D.III	Captured	N/K	R.C. Steele	John Lloyd Williams
15th Oct 17 0825	Bristol F.2b A7194	Albatros D.III	Destroyed	Shellah- Sharia	R.C. Steele	John Lloyd Williams
30th Oct 17 0925	Bristol F.2b A7194	Two seater	Captured	NW of Al-Khalasa	Arthur Peck	John Lloyd Williams
6th Nov 17 1045	Bristol F.2b A7194	Rumpler C	Landed but Destroyed	Um Dabkal	Arthur Peck	John Lloyd Williams
8th Nov 17 1300	Bristol F.2b A7194	Albatros D.III	Destroyed	Hulayqat	Arthur Peck	John Lloyd Williams

The two victories of this aircraft when crewed by Steele and Williams are described as follows:

8th of October 1917 - 2nd Lt. R.C Steele (Canada) and Lt. John Lloyd-Williams drove down the Albatros, Serial No.636/14 of Oblt. Dittmar of Fab300. This was the first German aircraft captured in Egypt. Pilot Steel was awarded the Distinguished Service Order (DSO).

15th of October 1917 - 2nd Lt. R.C Steele (Canada) and Lt. John Lloyd-Williams destroyed an Albatross D.III. Initially the enemy pilot indicated he was surrendering, but then tried to make for his lines and had his wing shot off.

The squadron handed over its Bristol F.2b aircraft to No.1 Squadron (AFC) in February 1918 after re-equipping with the single seat SE5a fighters.



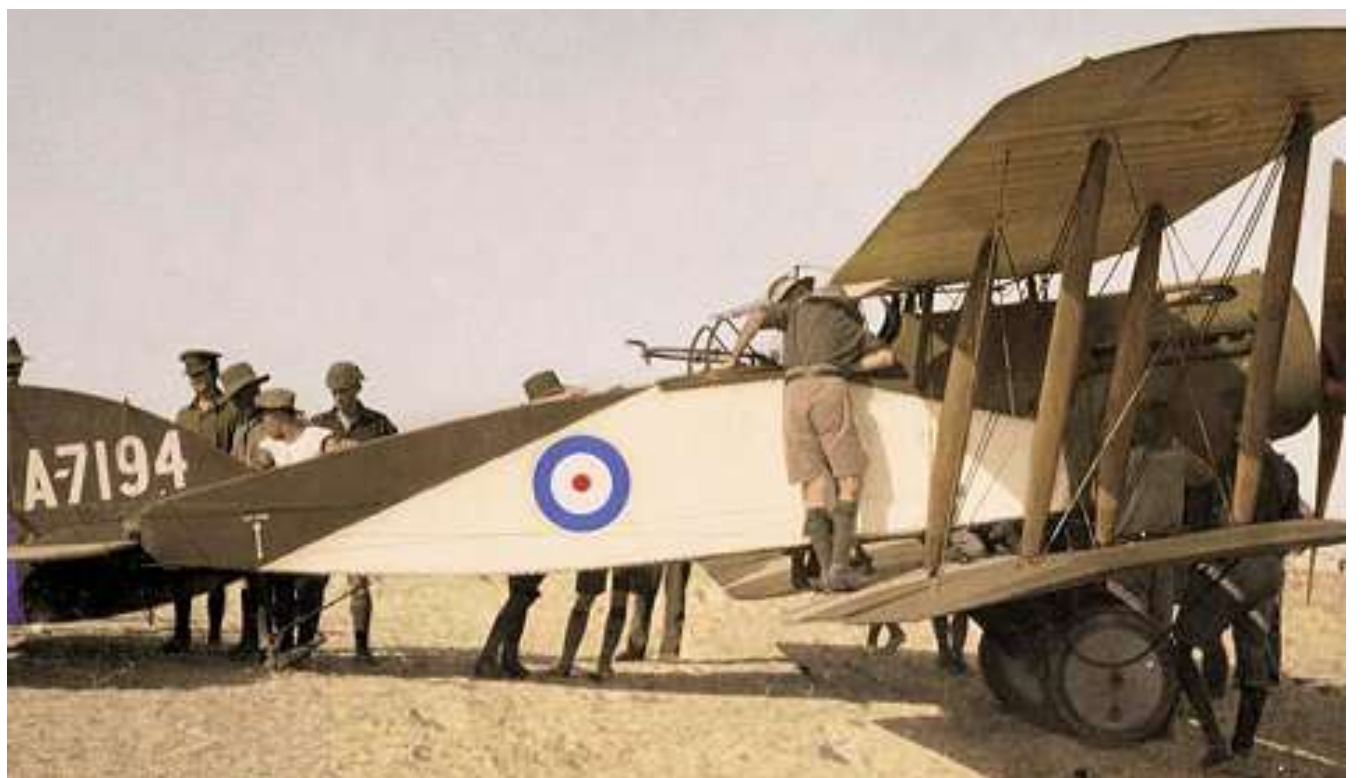

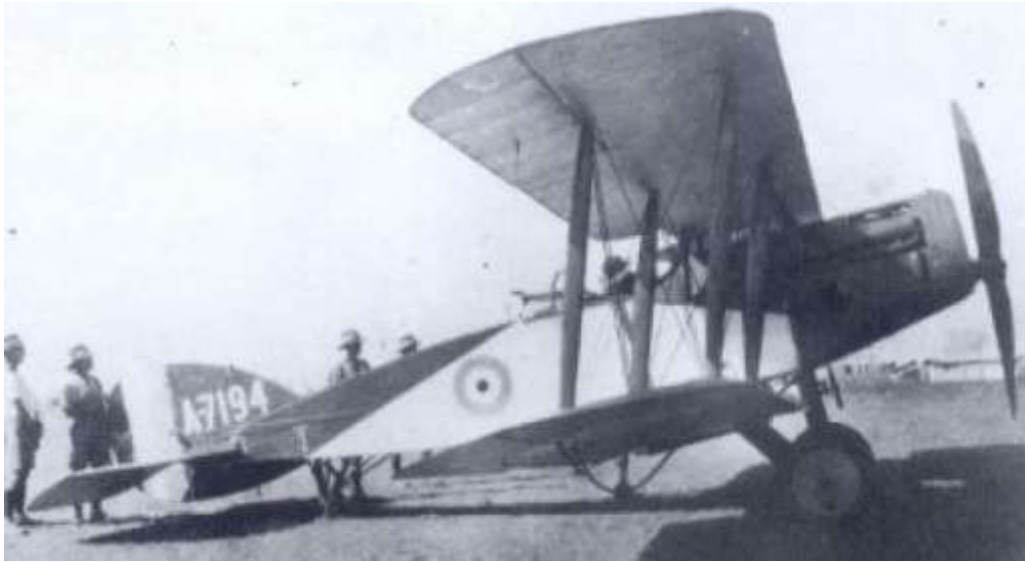

Painting by Norman Clifford



NOTE: Of interest is the 1:48th scale die-cast model of this aircraft from CORGI (AA28803). The model notes that the aircraft flew with No.111 Squadron (RFC) in October 1917, which would be correct for that time frame. The crew are stated as being Capt. Arthur H Peck (pilot) and Lt. John Lloyd-Williams (observer), who were aircrew in No.111 Squadron.

However, the colour scheme depicted for the model is, I believe, incorrect and is in fact the scheme used when the aircraft was being flown by No.1 Squadron (AFC) in 1918.



No.1 Squadron (AFC):

No.1 Squadron (AFC), operating from El Mejdel, Palestine, began to replace its RE8 two seater aircraft with the Bristol F.2b aircraft in early 1918. By the end of March all older types had disappeared and the squadron comprised eighteen Bristol Fighters. The Mk.1 Bristol Fighters (190hp Rolls-Royce engines) were gradually replaced during 1918 by the Mk.3 type (260-h.p. Rolls-Royce). No.1 Squadron (AFC) carried out most of the Army's distant reconnaissance missions and all the photography for map-making purposes. It also carried out frequent bombing patrols and special escorts, its pilots regularly seeking out the enemy for combat. The Squadron operated with No.111 Squadron (RFC) and later No.142 Squadron (RFC) as part of the 40th (Army) Wing (RFC). The wing formed part of the Palestine Brigade (RFC). The other part of the Brigade was formed by 5th (Corps) Wing (RFC), comprised of No.14 and No.113 Squadrons (RFC).

Bristol F.2b, Serial No. A'7194 was transferred from No.111 Squadron (RFC) via Kantara to No.1 Squadron (AFC) on the 11th of January 1918 as can be seen in the following record log. During its time with No.1 Squadron (AFC), this aircraft was flown regularly over February and March 1917. It also seems to have had a few problems that required subsequent air tests after maintenance.

The following flight entries were extracted from the records of the Squadron found on the Australian War Memorial web site - <https://www.awm.gov.au/collection/B01646>

Delivery of A7194 to No.1 Squadron (AFC)

11.1.18		Machines Serviceable 14 - Unserviceable 4.
0815 to 1050	Strategical Reconnaissance - TULKERAM - KAKON - NABLUS - HUWARA (Pilot Lieut.C.C.Cameron, Observer Lieut.W.A.Kirk escorted by Pilot Lieut.R.A.Austin M.C., Observer Lieut.R.A.Mustard)	
0930 to 1230	Strategical Reconnaissance - JERICHO - TALAT ED DUMM - RIJM EL BAHR (Pilot Lieut.T.Taylor, Observer Lieut.F.Hancock)	
One new Bristol Fighter (Mk.I Rolls Royce) No.A7194 arrived from KANTARA and was taken on charge of Squadron.		
Time flown during the day - 33 hours 30 minutes.		

Typical example of No.1 Squadron record log.

TYPE	Pilot.	Observer	Duty	Hour of		Duration	
				Departure.	Return	Hrs	Mins
B.F. 1148	Lt.Spragg	Sgt.Thomas	Test	0810	0840		30
" "	Lt.Spragg	Lt.Beaton	Reconnaissance(Strat)	1010	1220	2	10
Mart 3946	Lt.Tonkin		Bomb Raid	1010	1130	1	20
" "	Lt.Garson		do	1008	1130	1	22
B.F. 1128	Lt.Austin	Lt.Finlay	Escort Duty.	1015	1145	1	30
B.F. 7200	Lt.Halg		Escort Duty	1035	1155	1	20
" "	Lt.C.Brown	Lt.Cushman	Reconnaissance(Strat)	1015	1230	2	15
Mart 3945	Lt.Watt		Bomb Raid	1005	1145	1	40
B.F. 1147	Lt.Cameron	Cpl.Stecker	Test	1645	1710		25
BE12 6328	Lt.Taylor		Bomb Raid	1005	1115	1	45
BE2K 6826	Lt.Curwen-Walker		Practice	1050	1125		35
" "	Lt.Headlam	Capt.Macaulay	To Ramleh	1215	1245		30
" "	do	do	To Julia	1505	1545		40
Mart 3944	Lt.Naughan		Bomb Raid	1010	1150	1	40
" "	Lt.Paul		do	1010	1150	1	40
B.F. 1146	Lt.Fraser	Cpl.Tucker	Test	0830	0900		30
" "	do	Lt.Kirk	Photography	1140	1215	2	35
" "	Lt.Kenny	Lt.Challiner	Photography(engine failure)	1145	1155		10
" "	do	do	Photography	1200	1245	1	45
						2	27

Flights of A7194 (P=Pilot O=Observer A/M= Airman A/G= Air gunner)

- 3 Feb 18 - Lt.L.M. Potts (P) Lt.Traill (O) Recon escort
- 4 Feb 18 - Lt. Kenny (P) Lt. Challiner (O) Photo Recon (engine fail at first attempt)
- 7 Feb 18 - Lt.L.M. Potts (P) Lt.Traill (O) Recon (gun fail at first attempt)
- 11 Feb 18 - Lt.L.M. Potts (P) A/G Jensen (O) Escort
- 12 Feb 18 - Lt.L.M. Potts (P) Lt. Challiner (O) Escort
- 13 Feb 18 - Lt. Peters (P) Lt. Challiner (O) Escort
- 14 Feb 18 - Lt.L.M. Potts (P) Lt.Traill (O) Formation flying
- 15 Feb 18 - Lt.L.M. Potts (P) Lt.Challiner (O) Escort
- 16 Feb 18 - Lt. Peters (P) A/G Jensen (O) Escort
- 17 Feb 18 - Lt.L.M. Potts (P) Lt.Traill (O) Escort
- 18 Feb 18 - Lt. L.M Potts (P) Lt. Kirk (O) Photo Recon
- 18 Feb 18 - Lt. L.M. Potts (P) Sgt Jones (O) Airtest
- 22 Feb 18 - Lt. L.M Potts (P) A/M Gillet (O) Airtest
- 24 Feb 18 - Capt. Smith (P) Lt. Mustard (O) Recon

26 Feb 18 - Lt. L.M Potts (P) A/M Jensen (O) Escort
28 Feb 18 - Lt. Kenny (P) Lt. Mustard (O) Photo
28 Feb 18 - Capt. Smith (P) A/M Luxton (O) Airtest
1 Mar 18 - Lt. Fraser (P) Lt. Kirk (O) Photo
2 Mar 18 - Lt. L.M Potts (P) Lt. Traill (O) Escort
3 Mar 18 - Lt. Peters (P) Lt. Traill (O) Phot Recon (engine problem)
4 Mar 18 - Lt. L.M Potts (P) A/M Shires (O) Airtest
6 Mar 18 - Lt. Kenny (P) A/M Jensen (O) Escort
8 Mar 18 - Lt. L.M Potts (P) Lt. Traill (O) Recon
8 Mar 18 - Lt. L.M Potts (P) Lt. Traill (O) flown to JULIS
9 Mar 18 - Lt. L.M Potts (P) A/M Auld (O) Airtest
10 Mar 18 - Lt. Paul (P) Lt. Challiner (O) Escort
11 Mar 18 - Lt Kenny (P) Lt. Cashman (O) WASHOUT
13 Mar 18 - Lt. L.M. Potts (P) Lt. Beaton (O) Recon
14 Feb 18 - Lt.L.M. Potts (P) A/G Jensen (O) Escort
15 Mar 18 - Lt. Burton (P) A/M Zander (O) Airtest
16 Mar 18 - Lt. LM Potss (P) A/M Marshall (O) Airtest
20 Mar 18 - Lt. L Petts (P) Lt. Traill (O) Recon
22 Mar 18 - Lt. Blake (P) A/M French (O) Airtest
23 Mar 18 - Lt. Tonkin (P) Lt. Challiner (O) Recon
26 Mar 18 - Lt. LM Potts (P) Lt. Dawson (O) Escort
26 Mar 18 - Lt. Adair (P) Practice
26 Mar 18 - Lt. Murphy (P) Practice
27 Mar 18 - Lt. Garson (P) Lt. Letch (O) **CRASHED at T/Off**

As I could find no further flight records for A7149, my assumption is that the aircraft was written off charge after the crash.

Colour profile by Ronny Bar.

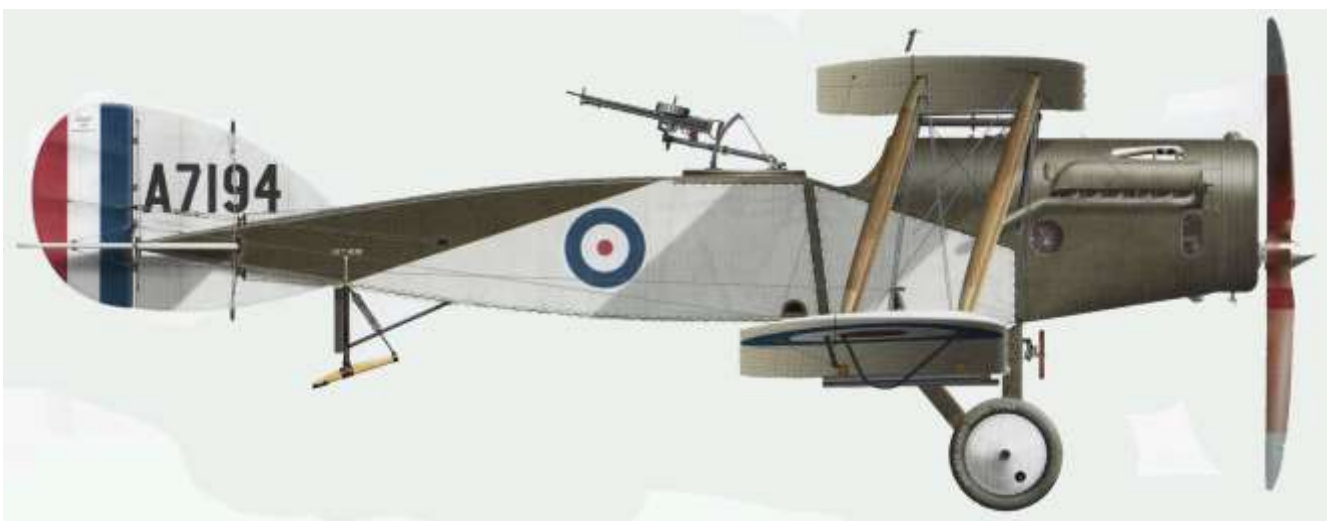

NOTE: According to the Australian War Memorial web site, the following photograph was taken by James Francis (Frank) Hurley at the No.1 Squadron (AFC) airfield at El Mejdel, Palestine in 1918.



Bristol f.2b with pilot (left), either Lieutenant Leonard Malcolm Sumner Potts or Lieutenant G. C. Peters. Taken at No.1 Squadron (AFC). The observer is Lieutenant James Hamilton Traill (right).

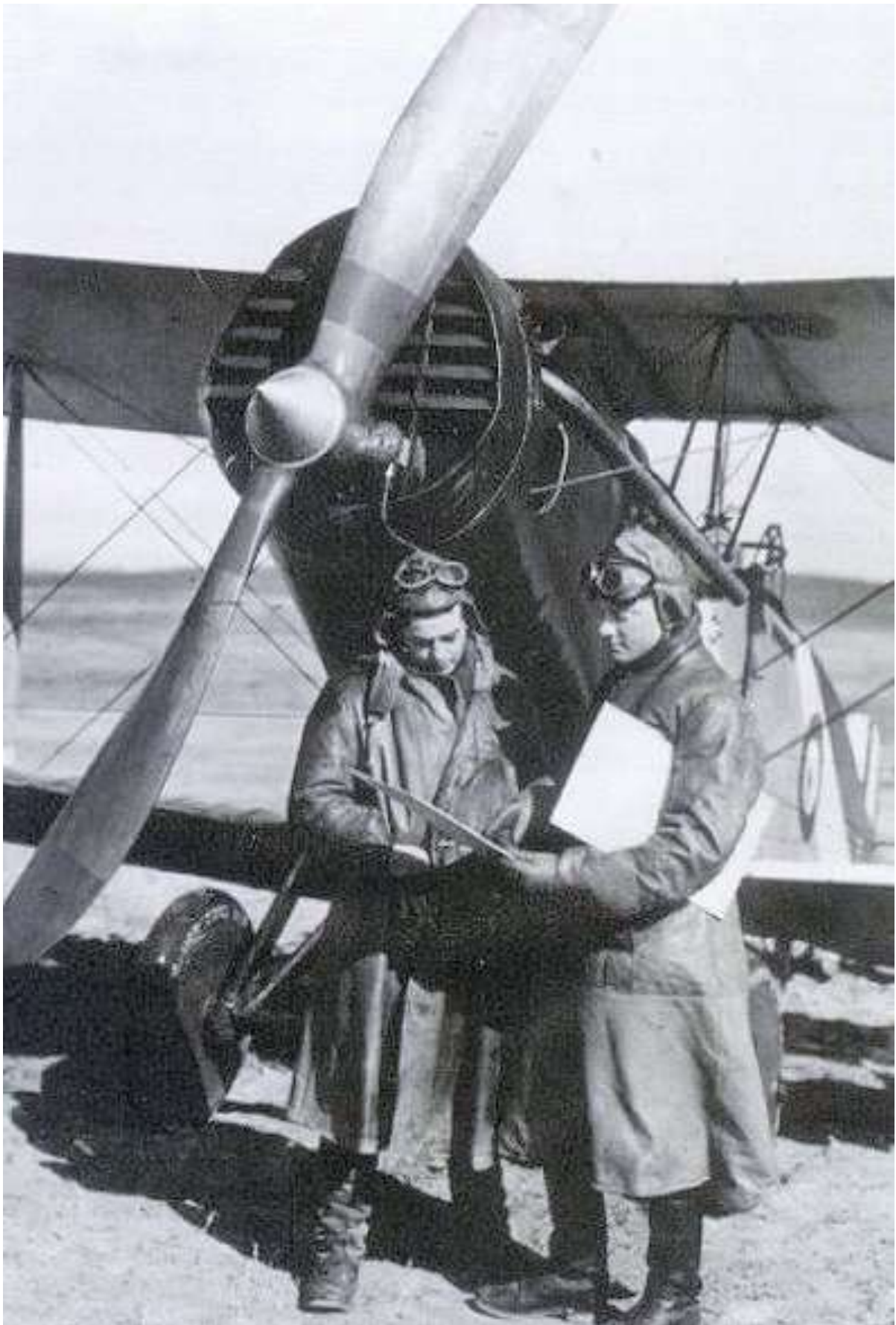

Palestine colour schemes:

It can be seen from photographs of aircraft operating in the Near East theatre that although some still had the Protective Covering (PC10) applied to the linen covered surfaces, others had a lighter off-white colour applied to the upper surfaces. It may have been an attempt to combat the heat of the desert sun or possibly that with air superiority secured, there was more possibility of losing an aircraft due to a technical issue than during combat and should a crew have to set their aircraft down in the desert, this scheme would make the aircraft more visible from the air for those sent to rescue them. Bristol F.2b Serial No.A7149 appears to be one of those aircraft, as can be seen in the previous photographs. It seems that the light, off-white dope was applied to the fuselage, tail unit and centre sections of the wings, rather than pure white or Aluminium dope, such as applied to some French aircraft. The previous photographs show this aircraft had at least two different colour schemes and style of the serial number, dependent on which Squadron it was being operated by.

Conclusions:

Given the available information, my assumption for A7194 when operating with No.111 Squadron (RFC):

It can be seen that the aircraft then had Protective Covering (PC10) dope applied to the upper, outer sections of both upper and lower wings and to the front and upper, rear sides of the fuselage as well as the upper and lower fins.

The remainder of the aircraft was doped in the lighter, off-white lighter colour with the undersides most likely left as CDL.

Given the available information, my assumption for when A7194 when operating with No.1 Squadron (AFC):

It can be seen that the aircraft then had Protective Covering (PC10) dope applied to the forward fuselage and upper rear of the fuselage sides. The remainder of the aircraft, including the wheel covers were doped in the lighter, off-white colour. The undersides were most likely left as Clear Doped Linen (CDL).

General:

It seems from photographs that these aircraft did not have standard light and PC10 dope colour schemes. Photographs of two other Bristol F.2b aircraft show the coloured dopes applied to different areas of the aircraft, as well as other aircraft which were doped totally in PC10 colour.

Bristol F.2b Serial No. A7198



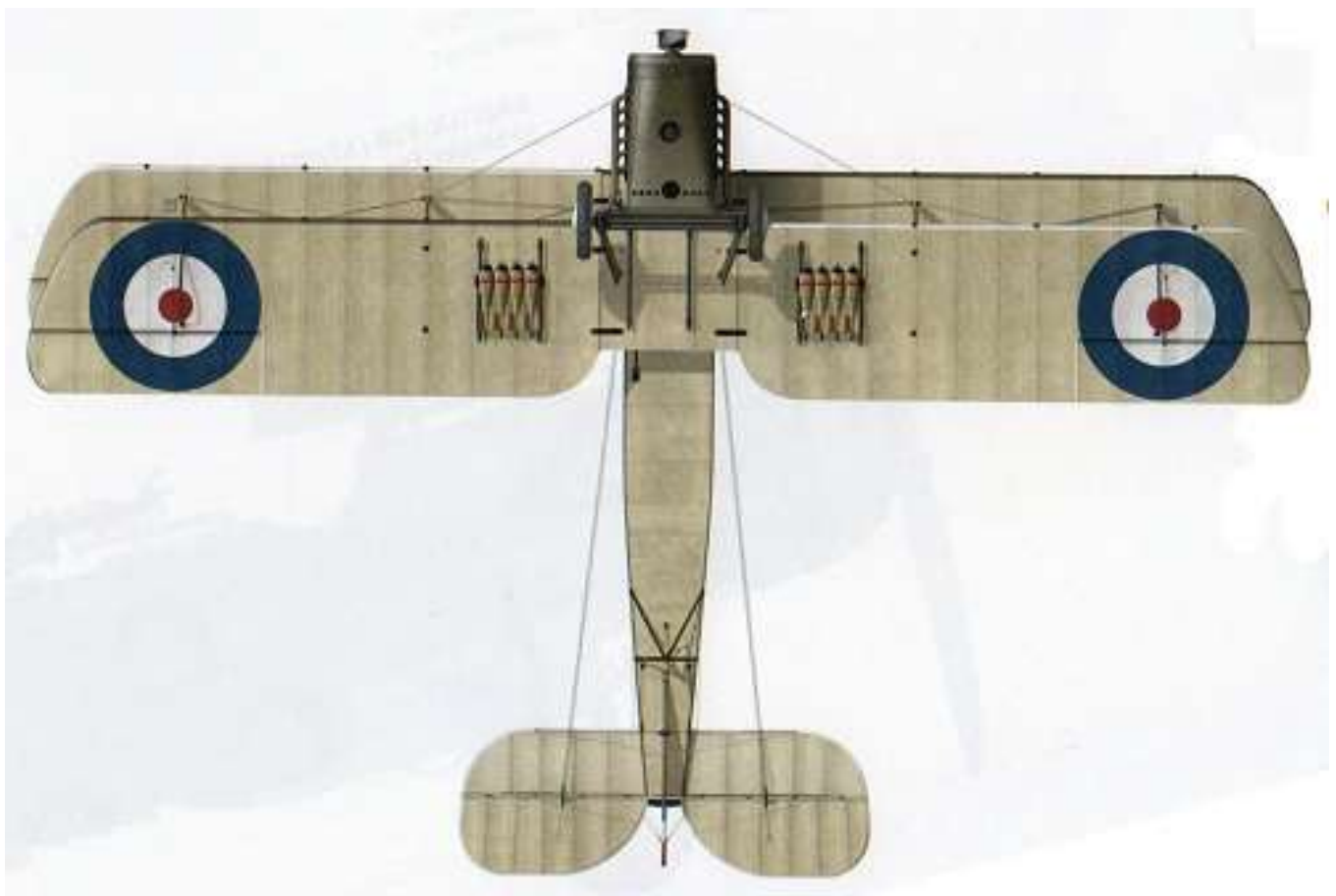
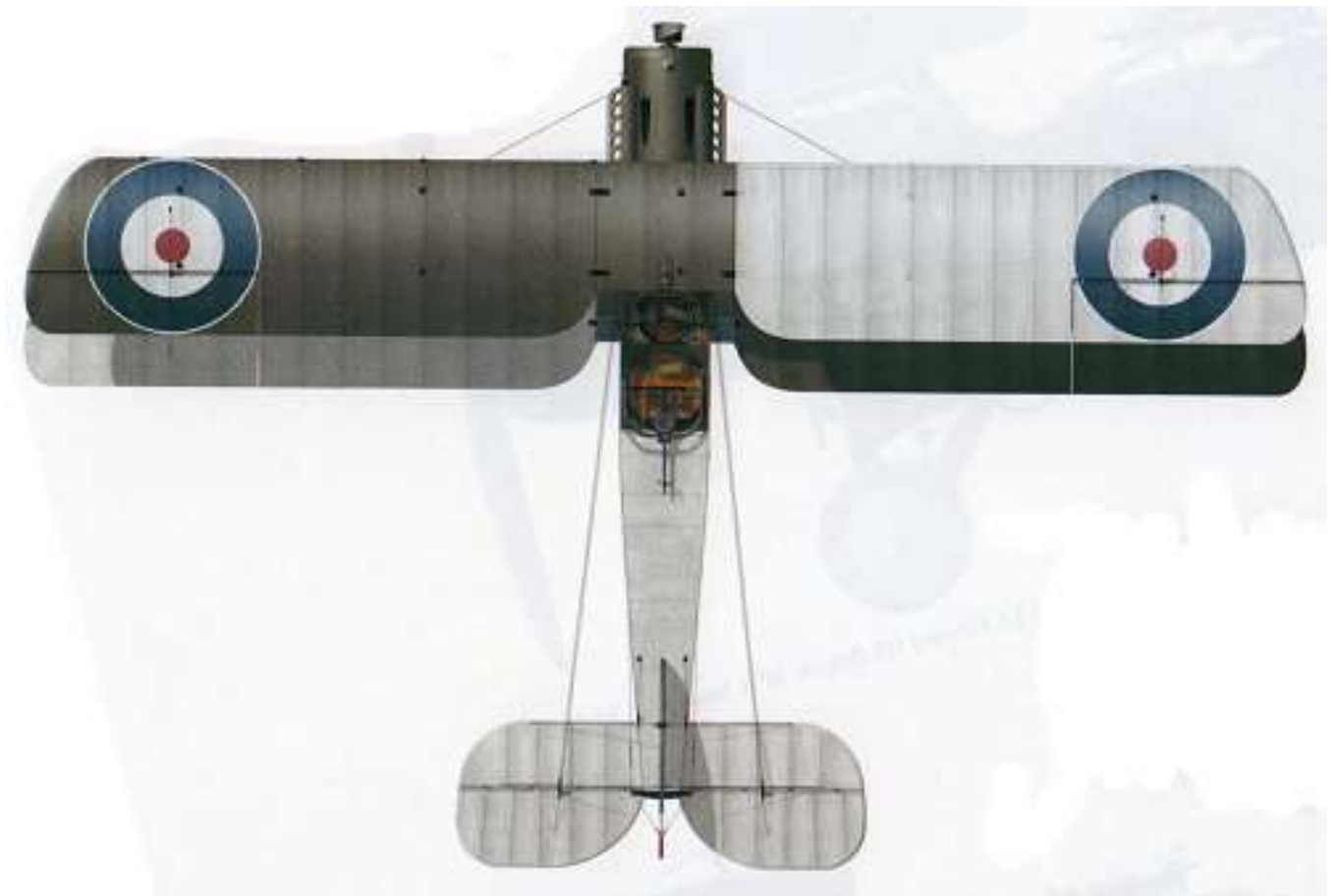

Bristol F.2b Serial No. A-7200



PART 3

WOOD EFFECTS

PART 3 - WOOD EFFECTS

A basic technique:

Parts of the model that are supposed to be made of wood can prove to be a challenge to replicate a wood finish to the part. Some after market companies produce accurate wood decals, which can be used to cover larger areas, such as cockpit decking and fuselage panels. However, decals can't easily be used to create realistic wood finish to smaller items or parts that don't lend themselves to having decals applied. To do this requires brush painting, using such as acrylic or oil paints, which can be enhanced with various washes or filters.

The first thing to do is to ensure the model parts are cleaned, normally with warm water with washing up fluid and something like an old tooth brush. Once cleaned and thoroughly dried, the primer coat can be applied. I use 'Tamiya' Aerosol Light Grey (Fine) or White (Fine) acrylic primer. Once the primer is dry, you can start applying the wood effect to the applicable cockpit items, such the cockpit framework, decking, seat supports, rudder bar, instrument panel and of course, the wing struts. With practice, this method can also be used on fuselage panels and propellers.

To start, apply a suitable base colour. For most painting I use an airbrush and only resort to brush painting when dealing with small items, when I add a few drops of 'Mr. Colour' Levelling Thinner', which aids brush painting. For most wood effect, I use 'Tamiya' Wooden Deck Tan (XF78) or Dark Yellow (XF60), suitably thinned with 'Tamiya' Thinners (X20A). Allow this base coat to fully dry (if you can't smell the paint, then it's dry).

Example of base coat using 'Tamiya' Wooden Deck Tan (XF78).

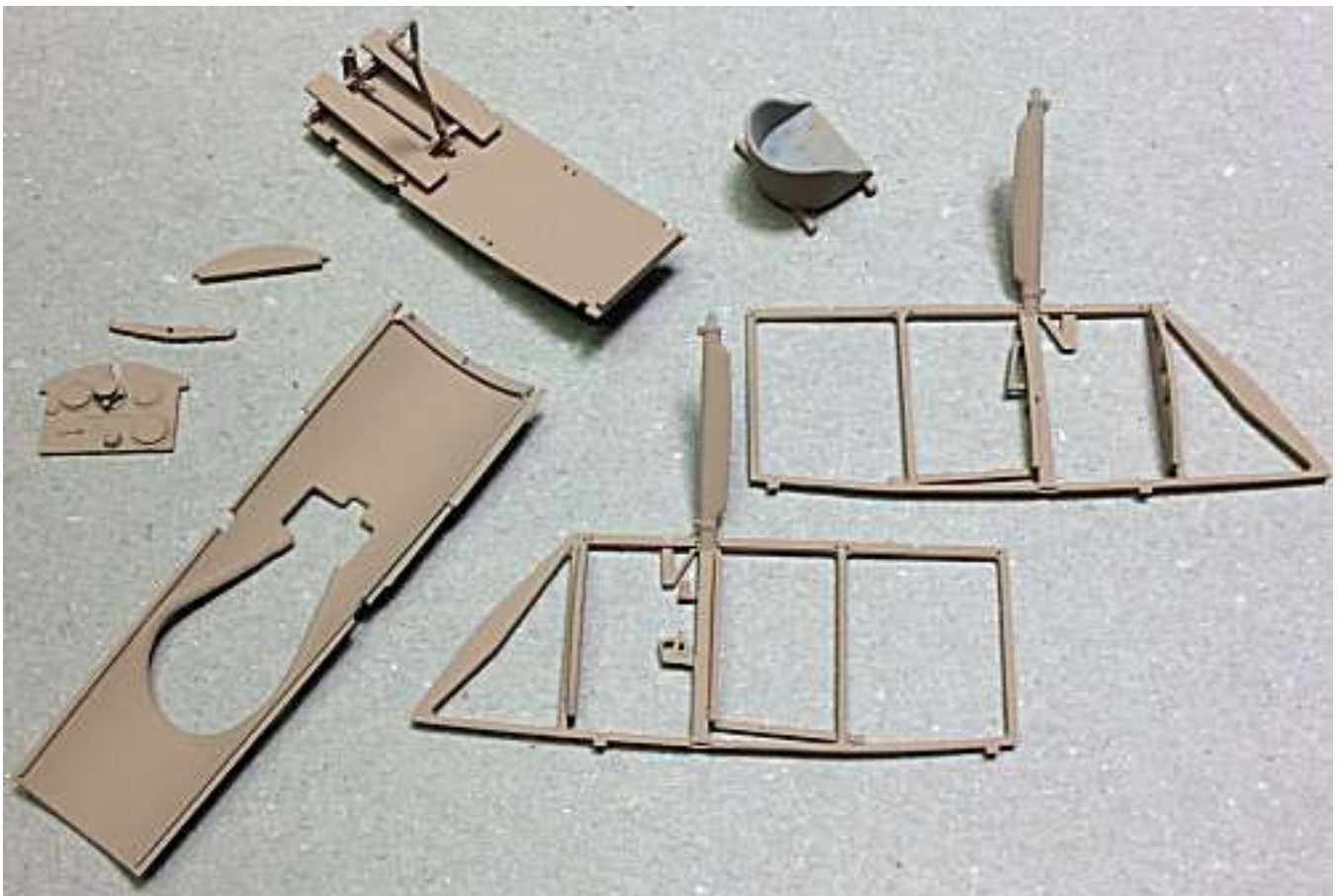

Wood effect - Method 1:

DecoArt Crafters Acrylic' paints:

For the next step I use 'DecoArt Crafters Acrylic' paints, either Burnt Umber or Burnt Sienna. These are similar to standard acrylic oil paints, but are water based instead of oil based. This paint is not as thick as oil based paint and is more creamy, so can be brushed and controlled more easily. Also, as it is water based, it's easy to clean your brushes, and if really necessary, can be thinned slightly with water. In addition, the paints dry as quickly as normal acrylic paints, avoiding the disadvantage of using true oil paints, which can take days to fully dry.

Place a small amount of the oil paint onto a non-absorbent surface and using a suitable oil paint brush (I use a slightly curved brush), wipe a small amount of the paint onto the brush. For larger areas, such as decking or panels etc I use a small piece of fine sponge to apply the paint.

Apply the paint to the applicable item, using light strokes and in the required direction. Apply the paint along struts and across instrument panels and other smaller items. This gives variation to the wood effect and for the wing struts, is correct for the direction of the wood grain. If you apply too much paint, just brush or sponge it off immediately before it dries. Although the paint is water based, don't try to thin any applied paint with water as it will lift the paint, which builds up into clumps. If required, a second light coat can be applied. Always wait until a first coat has fully dried before applying a second coat, otherwise the first coat will 'drag' and lift from the surface.

Once painting is complete, clean the brush in water.

Below is an example of the Burnt Sienna oil paint applied to a cockpit side frame.



Wood effect - Method 2:

Windsor & Newton' Griffin (Alkyd) oil paints:

NOTE: *The wood effects can also be achieved using 'Windsor & Newton' Griffin (Alkyd) paints.*

Mask off the area as required.

NOTE: *When airbrushing 'Tamiya' acrylic paints, I thin the paints using 'Mr. Colour' Self-Levelling Thinners (400), which is commonly referred to as 'unicorn tears' or just 'MLT'.*

Airbrush the areas with 'Tamiya' Dark Yellow (XF60) or similar.

Brush a covering coat of the 'Windsor & Newton' Griffin Alkyd paint, such as Burnt Sienna, over the areas.

Leave the oil paint to settle for about ten minutes.

Decant a small amount of White Spirits or 'AMMO Mig' enamel odourless thinners (A.Mig-2019), into a suitable dish.

Dip a broad flat oil brush into the thinners then wipe the brush on a sheet of kitchen roll, which should not deposit any fibres in the oil paint.

Brush the oil paint over the area, in the desired direction of the wood grain, wiping the brush on the sheet of kitchen roll to remove residual oil paint.

Repeat dipping and wiping the brush in the thinners and brushing the oil paint until the desired density and finish is achieved.

Leave the oil paint to fully dry, which normally takes approximately 24 hours.

If desired and once the oil paint is fully dry, airbrush a semi-gloss clear coat, such as 'Alclad' Satin (ALC312-60) or similar, with a few drops of 'Tamiya' Clear Orange (X26) to give a varnished look to the finish.

Surface finish:

Once the oil paint layers have dried, the final top coats can be applied to give the final effect of varnished wood.

'Tamiya' have 'Clear' coloured Acrylic paints, which are intended to be mixed with either Flat Clear (XF86), Semi-Gloss Clear (X35) or Clear (X22), to give the required finish but with a tint of the added 'Clear' colour. I use the Clear Yellow (X24) or Clear Orange (X26) to add a varnished tint to the clear coat. If using the 'Tamiya' Clear I add 'Mr. Colour' Levelling Thinners, which does improve airbrushing and avoids pooling. Otherwise I use 'Alclad' Light Sheen (ALC-311).

Although it's a lacquer, I've found that it will accept 'Tamiya' 'Clear' coloured Acrylics without any separation, which can happen with other paints. The 'Alclad' lacquers dry fast and provide a good sealing layer over the painted surfaces. When using 'Alclad' sealing coats, the golden rule is to allow the various painted surfaces to dry fully before applying 'Alclad' lacquers.

In the following example, I added a few drops of Clear Yellow (X24) into the 'Alclad' Light Sheen (ALC -311) and thoroughly mixed it. Only add small amounts to the 'Alclad' in order to control the amount of tint you desire. I increased my airbrush air pressure to around 20 psi to airbrush the sealing coats over the various cockpit items. The first coat usually dries to a more matte finish, which I assume is due to being sprayed onto the oil paint, rather than onto straight acrylic paint. Once this first coat has dried, I airbrushed several coats of just 'Alclad' Light Sheen (ALC -311), which added not only more sealing coats, but more importantly gave the desired semi-gloss 'varnished' finish I was after.

Below is an **example** of the applied Alclad lacquer/X24 mix on the propeller.



NOTE: *Once you are confident using this method of replicating wood finishes, you can vary both the colour of the acrylic base coat and tinting of the sealing coat, to replicate other types of wood used in aircraft construction.*

Once the lacquer coats are thoroughly dry, any detail painting, decals or final weathering can be applied to the parts, as required, prior to fitting them to the model.

PART 4

WEATHERING

PART 4 - WEATHERING

There are many different types of weathering mediums available now to modellers of aircraft, ships, vehicles and figures, in model of any type. These weathering mediums can be washes based on enamel, clay or ink. Weather pastels, applied by sponge' as well as oil paints of various sorts are also plentiful. Some modellers have even used water colour paints, and pencils. The following are the basic weathering mediums I tend to use on most of my models.

Flory Model clay washes:

The washes I tend to use are the 'Flory Models' Clay Wash 'Grime' and 'Dark Dirt', which come in various shades and consist of a suspended and very fine clay pigment. They are brushed over the surface to be weathered and dry in around 30 minutes. When dry, use either a piece of good, absorbent kitchen roll or a soft brush to remove as much of the clay wash as you need to achieve the desired effect. The kitchen roll can be used dry or very slightly dampened. If dampened, the dried clay is re-activated and the clay wash can be more easily be removed or worked as required.

First I seal the surface with an airbrushed semi-matte clear coat, such as 'Alclad' Light Sheen (ALC-311), which dries quickly. A gloss coat tends to stop the clay wash 'gripping' the surface when it is applied and it can run off or just puddle. A more matte coat can cause the clay wash to 'grip' too much, making it difficult to remove or even to wash it off completely.

NOTE 1: The more glossy the applied sealing coat is, the more the chance there is that the applied 'Flory' clay wash will not spread fully, but rather form puddles or beads of wash. If this happens, add a few drops of ordinary kitchen washing up liquid to the clay wash. This will break the surface tension of the wash, allowing it spread fully.

NOTE 2: Always decant the amount of clay wash you need, rather than dipping the brush directly into the wash bottle. Dipping into the wash bottle can transfer contaminants from the brush into the wash, will can cause the wash to become thick and unusable.

NOTE 3: When a sealing coat is applied over areas treated with clay wash weathering, the intensity of the applied wash tends to darken. This should be considered when removing the clay wash, otherwise the final effect may appear too dark.

NOTE 4: 'Flory' current range of washes are: Dark Dirt, Grime, Black, Light (white), Mud, Sand, Rust and Concrete. All of these washes can be mixed to create many colour shades for different weathering finishes.

To apply the clay wash is just a matter of brushing all over the surface to be weathered. It doesn't matter really how much is applied as it can be left on for any period, as it is easily removed without any effect on the surface underneath. If you don't achieve your desired effect, you can wash it all off and start again. Use a soft brush or absorbent kitchen roll, which are dry or **very slightly** dampened, to brush or wipe off the clay wash in the direction of airflow over the model. Even then, dab them onto a dry piece of the paper, until they are almost dry. Any wetter and you'll find that you are removing too much of the clay wash. If that happens you can re-apply the wash and start again. If you're not happy with the final effect, you can easily remove the clay wash by brushing with a wet brush or even airbrush water over the surface. Dry off the surfaces washed and then re-apply the clay wash and try again until you are satisfied. The technique is to 'damp' brush or wipe over the surface to re-activate the clay wash and at the same time, to smear it over areas that had no clay wash. It'll dry within 30 minutes. Then very lightly brush and/or use a piece of damp absorbent paper to remove as much you want until you get the desired effect. Once finished, run the brush under a tap to rinse out any residual clay pigments. Finally, seal the surface with your chosen clear coat, which will seal in the applied clay wash.



Chipping effects:

To give the effect of chipped and weathered paint/varnish to metal engine cowls and forward fuselage panels etc, chipping fluids can be used. To achieve this effect, first prime the areas with a suitable primer then airbrush the metallic finish desired. Once dry, a chipping fluid, such as 'AK Interactive' Medium Chipping fluid or 'Vallejo' chipping fluid is airbrushed over the painted areas. An alternative is to use a cheap hair spray. This forms a barrier which will allow the top coat to be chipped off. Finally the required top coat colour is applied. Once fully dry, moisten the top coat with water, which softens the paint. Then with a cut down (stiff) brush and wood cocktail stick, gently teased off the top coat paint. Take care when doing this as 'too much chipping' can't really be covered up. In that event you would have wet the top coat and remove it all with an old toothbrush or similar and then when dry, re-spray the top coat and try again. Once the desired effect was achieved, I sealed the surfaces with an airbrushed coat of 'Alclad' Light Sheen (ALC-311).



'Tamiya' Weathering Master sets:

Each of these 'Tamiya' produced weathering sets contain three 'tablets' of different colours and an applicator, which has a brush on one end and a sponge on the other. The tablets have a wax look and feel and can be applied onto painted surfaces to reproduce various finishes. It's best to use these as the final surface treatment, as being a 'Wax', any treated surfaces can't be painted or sealed.



Pigments:

Pigments, such as those produced by 'Flory Models' or 'Humbrol' are effectively very fine 'dusts', which can be applied to a model to re-create dust, dirt, stains etc. They can be applied by dry brushing or mixed with other mediums to create paintable solutions.



Washes:

Washes can be applied to either enhance panel lines etc or to add a 'filter' of colour onto a painted surface. They can be purchased ready made from various manufacturers or can be 'home made' using such as oil paints with a suitable thinning agent. I tend to use 'AK Interactive' products.



Water colour pencils:

Water colour pencils can be used to add weathering detail. The colour s applied to the model part then brushed gently with a brush, slightly dampened with water. This dilutes the pencil marking, allowing it to be faded as desired. 'AK Interactive' produce these 'weathering' pencils, which are marketed specifically for the modeller, although other artist water colour pencils can be used, such as 'Derwent' Inktense 24 ink pencils.



Oil paint:

A technique used more frequently now is oil paint 'dot and drag'. Basically an oil paint of the desired colour is placed onto a piece of cardboard, which over a hour or so, soaks out the oil in the paint, leaving a drier pigment. The pigment is 'dotted' onto the painted surface where it is required then dragged with a brush previously wetted with 'Tamiya' X20 enamel thinners then wiped virtually dry.

Softly drag the brush to drag the pigment in the direction required, which will blend it in a thin layer.

The amount of pigment left showing depends on the effect you require. Always keep the brush wiped clean to avoid a build up of pigment and remoisten and wipe dry often. The more paint you drag, the less pigment is left showing. Blending different coloured pigments can create stains from smoke/gun blast, rain marks/runs, dirt/dust and oil/fuel stains.

A good quality oil paint and thinners are essential to produce a good finish. Some quality oil paints can be too 'gritty' when leached of oil, so I use 'Abteilung 502' oil paints and 'Tamiya' Enamel thinners (X20).



PART 5

DECALS

PART 5 - DECALS

Standard decals:

NOTE: *The following is **applicable only** for decals on a **painted surface**. If decals are to be placed on top of **previously applied decals**, the decal setting solutions, **if used**, may 'eat' into the previous decals. In this case a sealing coat of clear gloss, such as 'Alclad' Aqua Gloss (ALC-600), 'Tamiya' Clear (X22) or similar should be airbrushed over the first decals, to provide a barrier against the setting solutions.*

Ensure the painted surface is smooth and free from any surface imperfections.

Airbrush a sealing coat of 'Alclad' Aqua Gloss (600), 'Ammo' Aqua Gloss Clear (A.MIG-2503), or 'Tamiya' Clear (X22) to provide a smooth surface.

NOTE: *'MicroSet' solution softens the decal to allow it to conform to the painted surface. Do not attempt to move the decal too much or it may tear.*

Wet the area using a light coat of 'MicroScale' **MicroSet** solution.

Apply the decal after it has soaked in 'warm' water enough to start to loosen the decals from its carrier backing.

Carefully move the decal into the correct position.

Once the decal is correctly positioned, use a flat brush to softly brush the water out from under the decal, working from the centre of the decal out towards the edges. I then use a dry cotton bud in the same manner. Finally, wearing cotton gloves, I apply slight pressure and slide my fingers across the decal to finally push the decal onto the surface.

NOTE: *'MicroSol' solution will soften the decal to allow it to conform fully to the painted surface. The solution usually causes the decal to wrinkle, but this is normal as the decal semi-dissolves to the surface. Once the solution has been applied, never try to disturb the decal as it will tear. Leave the solution for several hours to do its job, after which the decal will return to a smooth surface, but conformed fully to the painted surface.*

Brush the decal surface with a light coat of 'MicroScale' **MicroSol** solution.

Leave the solution for several hours to fully dry and set the decal.

Once the decals have been applied and are dry I airbrush a final sealing coat of 'Alclad' Light Sheen (ALC-311) or 'Tamiya' Semi-Matt (XF35) over the decals.

'Aviatic' linen effect decals:

The 'Aviatic' decals are different in both production techniques and application to those of the more traditional decal manufacturers. Traditional decals are normally created using processes such as silk screen printing and are pre-shaped for the particular model markings. When placed in warm water they will detach from the backing sheet and can then be slid onto the model surface and when they are correctly positioned, wiped with a semi-dry brush or cotton bud etc, to expel any water from under the decal. Once fully dry, decal softeners, such as 'MicroSol' and/or 'MicroSet' can be applied, if necessary, to 'weld' the decal to the model surface. Finally a sealing coat of acrylic or lacquer gloss, semi-matt or flat is applied over the decal, to seal and protect the seal and protect the decal. However, 'Aviatic' decals are laser printed onto a very fine carrier film and although this film is thin, the decals are remarkably resilient and somewhat 'stretchy' when being applied. This allows them to be more easily moved and positioned before being finally applied. Also with most other decals, I've used softeners to help the decals conform to surface irregularities and contours, which is something I've found is not really required for 'Aviatic' decals, due to the nature of the carrier film.

In addition, the decals need to be cut out from the sheet, so care is required to cut the decals accurately to avoid leaving gaps, especially at the edges, where the white base colour will show. That said, minor gaps may be able to be covered with weathering. For more information, refer to the 'Aviatic' instruction sheet supplied with the decals.

'Aviatic' decals are laser printed onto either 'clear' or 'white' backing, the 'clear' being dependent on the base coat you apply and the finished effect you desire. The decals are supplied with very clear instructions on their application, including when to add pre-shading to the base coat, where desired, before you apply the decals. For this model I chose to use the 'clear' decals, in order to show the linen effect more visibly.

Application:

As the decal is to be applied over a coloured base coat (green, brown etc), first airbrush a primer coat of 'AK Interactive' primer and micro-filler White (AK759) or Gey (AK758) or similar on all of the surfaces to have the decals applied.

NOTE: *'Silvering' is caused by air being trapped in the rough surface of the paint, such as on a matte finish, which after the decal is applied and dries, causes silver sheen patches showing in the decal ('silvering').*

Once dry, check the surfaces for any imperfections, such as trapped dust or raised areas of paint, which will cause 'silvering' under the decals. Any surface imperfections found should be carefully sanded or polished out.

Airbrush the required base colours to the model surfaces.

Once dry, check the surfaces for any imperfections, such as trapped dust or raised areas of paint, which will cause 'silvering' under the decals. Any surface imperfections found should be carefully sanded or polished out.

Airbrush at least two light sealing coats of 'Alclad' Aqua Gloss (ALC-600) or similar, which will form a gloss surface for applying the decals.

NOTE: *The surface must be pre-wet with like warm water with. Care needs to be taken when you slide the decal from the backing sheet and onto the model surface, as the thin decal can fold over on itself.*

Soak each decal in warm water for approximately 20 seconds.

Wet the surface of the model where the decal is to be applied.

Carefully slide the decal onto the wetted surface. Make sure the decal does not fold over on itself.

Align the decal to the shape of the model part.

Using a broad, soft brush, brush the decal from the centre outwards to remove any water from under the decal.

Adhere the decal to the model part surface by either pressure rolling over the decal with cotton buds or, as I do, by wearing lint free cotton gloves and rubbing the decal with your fingers.

Check to make sure the decal is in full contact with the surface of the model part and that there are no areas exhibiting 'silvering' (trapped air under the decal). If so, gently prick through the decal and apply water then press out the water to adhere the decal back onto the model part.

Also check that there are no lifted decal edges around the model part.

Allow the decal to fully set, preferably overnight. Where decals have been applied to large areas, gentle heating using a hair dryer can accelerate the decal setting time.

Where decals cover location holes or other openings, prick or cut through the decal into the hole or opening then apply 'Tamiya' X20A thinners, which will soften and adhere the decal into the hole or opening. Using X20A can also conform decals around curves edges etc.

Protect and seal the decals by airbrushing a sealing coat over the decals. If more decals are to be added onto the applied decals a gloss sealing coat should be used. Otherwise a sealing coat of the desired finish can be applied, which should also be done once all of the required decals have been applied.

PART 6
RIGGING
(GENERAL)

PART 6 - RIGGING (GENERAL)

One of the first thing to do when pre-rigging a model is to make sure you have already drilled out the rigging attachment points. Most models have these located on the model, but it's best to carry out research in reference books or research on line before drilling.

Some modellers use micro drills manufactured for drilling printed circuit boards etc and these drill bits sometimes have identifying coloured collars fitted to the drill shanks. I have found that care needs to be taken when using these drills, as they are sharp and instead of easing their way into the plastic of the model, they tend to bite in and effectively 'cork screw' their way in, which causes jamming and lots of broken drills. This is not only expensive but can leave broken drill bits in the model, which are virtually impossible to extract. An alternative is to use High Speed Steel (HSS) drill bits, which are cheaper and have less 'bite' when in use, although again, they are very fragile and can very easily be broken.

Some modellers drill through the wings etc of the model and rig by pulling through the rigging line/EZ thread etc, gluing in position and then rubbing down the exposed line 'tag' and re-painting that area. I prefer to drill only part way into the plastic and attach the applicable rigging fixture with CA adhesive.

NOTE: *The Bristol F.2b aircraft was structurally rigged with solid forged steel 'wires', which were either streamlined (aerodynamic) wires or round section wires. These differed from standard round wire wound cable in that they were forged steel lengths with handed threads at each end, which were screwed into special end fittings in the aircraft.*

The streamlined wires were shaped to offer the least wind resistance during flight and so reduce drag on the aircraft. These wires were used for such as flying, landing, incidence and bracing wires.



The round section forged wires were used more for cross bracing where drag reduction was not so much of an issue, such as lower wing to fuselage, fuselage cabane struts and flight control surfaces (rudder, ailerons, elevator) to their control horns.

Regardless of the installation, each wire had an end fitting at both ends.



Although I have used photo-etch Aero wire before, I found that it was too flimsy when fitted and liable to bow if the end fittings were not correctly aligned to the wires. Also the only realistic end fittings are those from 'Gaspach Models' and are resin, which is weak and liable to break. Also using stretch line such as 'EZ' does not give any structural strength to the completed model and can be difficult to colour as the lines are normally black, white or blue and not steel coloured.

Therefore I choose to rig using micro-tube or various diameter and mono-filament (fishing line) of 0.08 or 0.12 mm diameter from such as 'Steelon' or 'Stroft GTM' line. Although not flat it requires close examination to see the difference. The advantage of using mono-filament is that when fitted it can be, if necessary, tightened using a heat source and the final rigging adds structural strength to the model, as it did on the actual aircraft.

Internal rigging:

Cross bracing wires:

The following illustration shows the cockpit cross bracing streamlined wires. These were fitted:

Across and between the cockpit sides frames at the front and rear frames and behind the pilots seat.

Diagonally crossed between the upper and lower frames in the cockpit side frames.

The wire end fittings were fitted at both end of the wires.

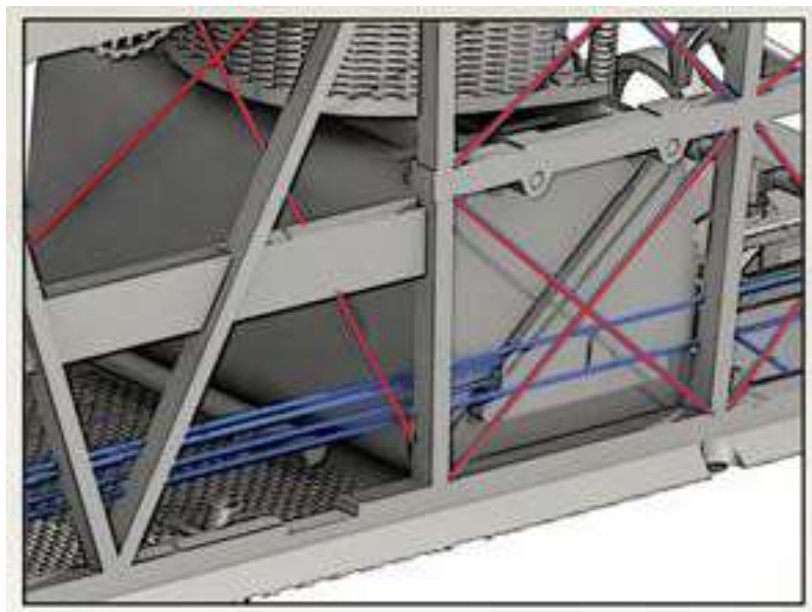

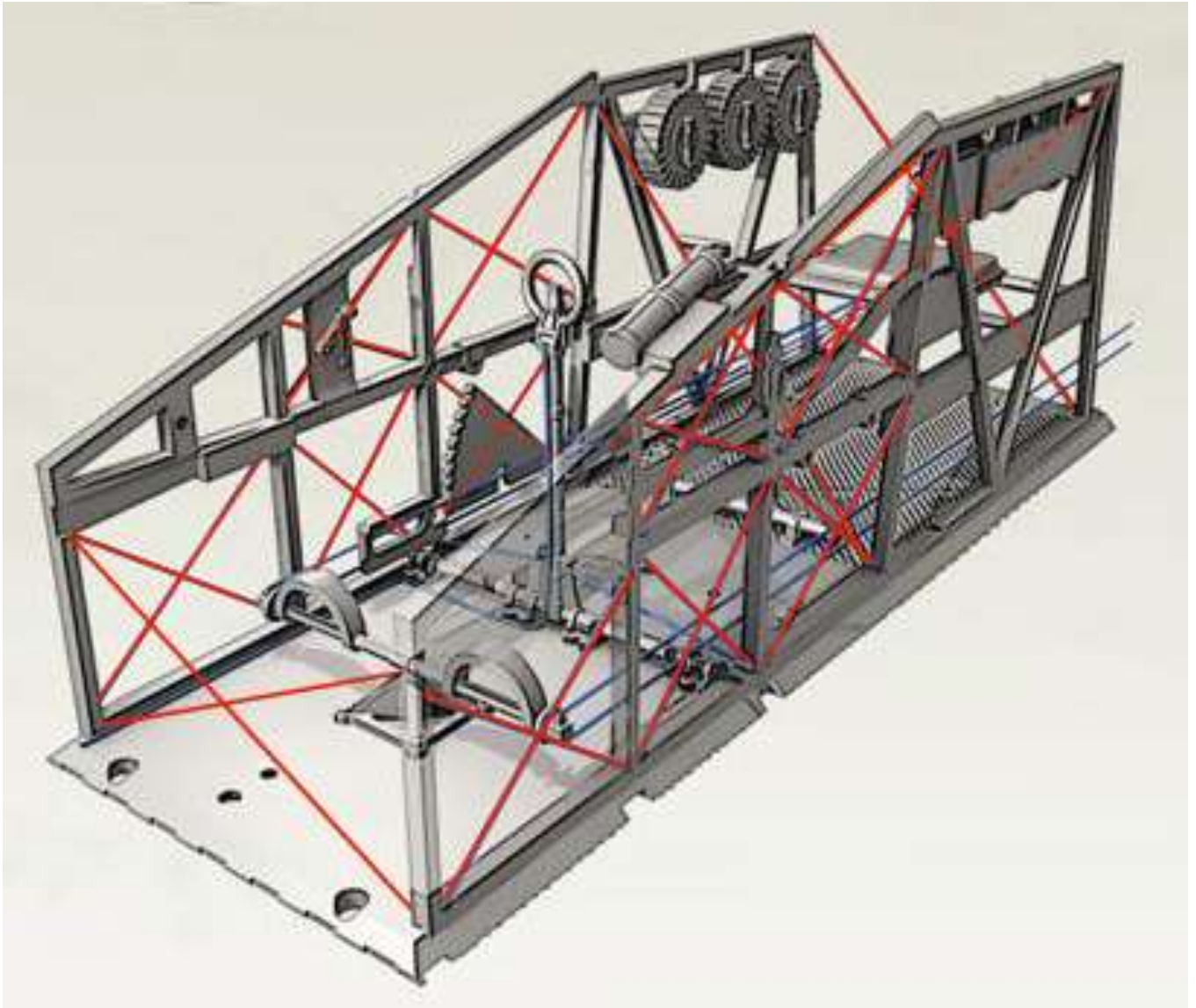

Rudder control cables:

A rudder control cable was looped around both ends of the pilots rudder bar to form dual control cables that were routed rearwards through the fuselage to exit at each side to be attached to the ends of the rudder control horn. The ends of the rudder control horns were interconnected with a single wire through the rudder. As the pilot moved the rudder bar left or right the cables would pull the rudder in the required direction, causing the aircraft to drift left or right (yaw).

The cables were the standard round wire wound type and visible turnbuckles were fitted into the cables towards the rudder.

Aileron control cables:

An aileron control cable was attached to the left and right sides of the pilots control column. These cables were routed outboard through the sides of the fuselage then across the lower wings. The cables entered the lower wings close to the forward interplane struts and were routed rearwards and out the undersides to the bottom end of the aileron control horns. The cable was connected between the wings to both upper and lower aileron control horns. From the upper aileron control horn, the cables were routed forward and into and across the upper wing.

As the pilot moved the control column left or right the cables would pull both ailerons on one side of the aircraft in one direction and the opposite ailerons in the opposite direction, causing the aircraft to bank left or right (roll).

The cables were the standard round wire wound type and visible turnbuckles were fitted into the cables at the control column.

Elevator control cables:

The pilots control column was attached at its base to the elevator control tube. At each end of the tube and outside the fuselage were the elevator control levers, which were attached to the external control cables of the elevator. As the pilot pulled back or pushed forward the control column, the external levers moved the control cables to change the angle of the elevator, causing the aircraft to climb or dive (pitch). As such no control cables were used inside the cockpit.

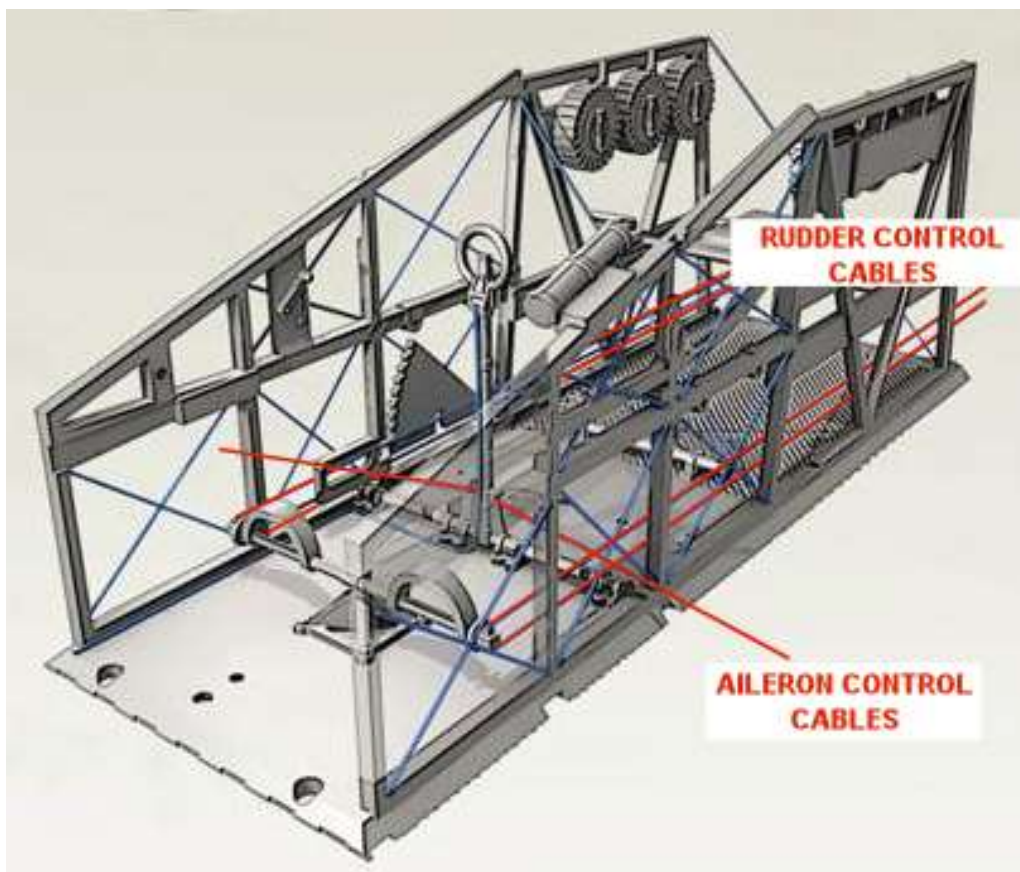



Tailplane incidence control cables:

The angle (incidence) of the tailplane could be adjusted from a control lever located on the right end of the fuel tank in the pilots cockpit. The lever could be moved up or down and locked in position on the lever quadrant. Control cables from the lever were routed rearwards and out of the upper and undersides of the fuselage to be connected to bell cranks attached to the torsion bar of the tailplane. As the pilot raised or lowered the control lever, the cables would cause the tailplane angle to be altered, which trimmed the aircraft in-flight.

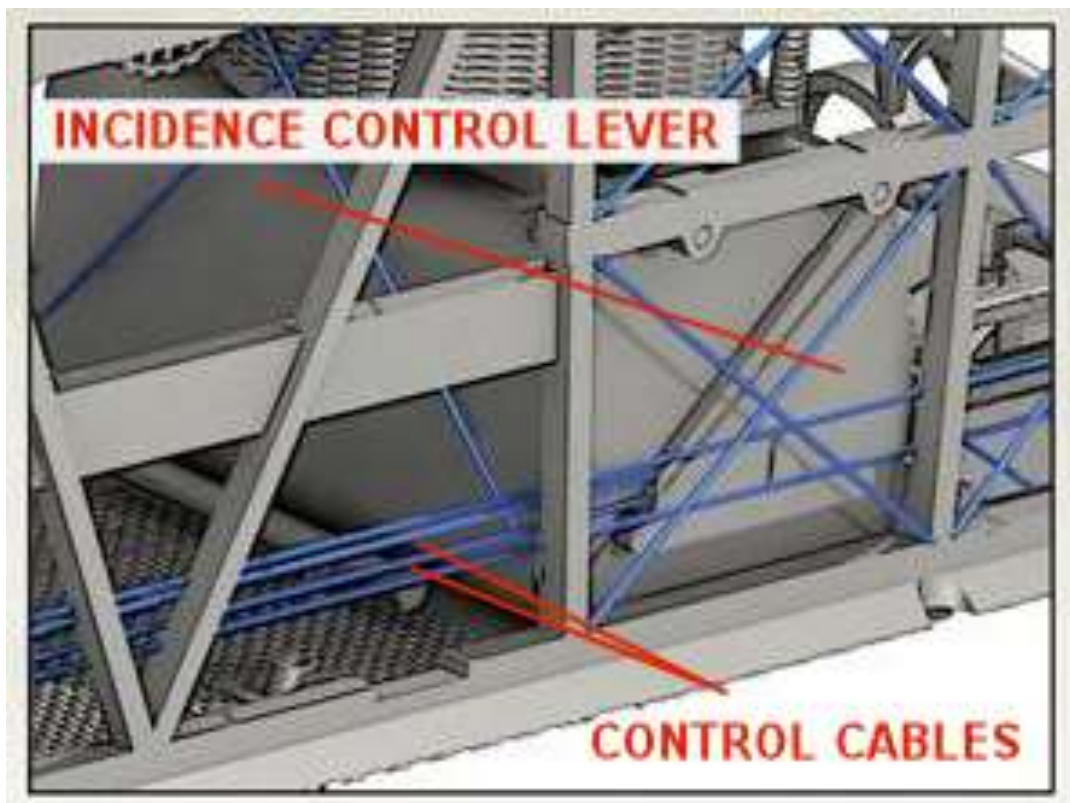

Engine bay bracing wires:

Streamlined bracing wires were fitted across the bottom, rear of the engine bearers and also across the top, rear sides of the bearers.

NOTE: *These bracing wires will not be added as they will not be seen when the engine and fuselage panels have been fitted.*

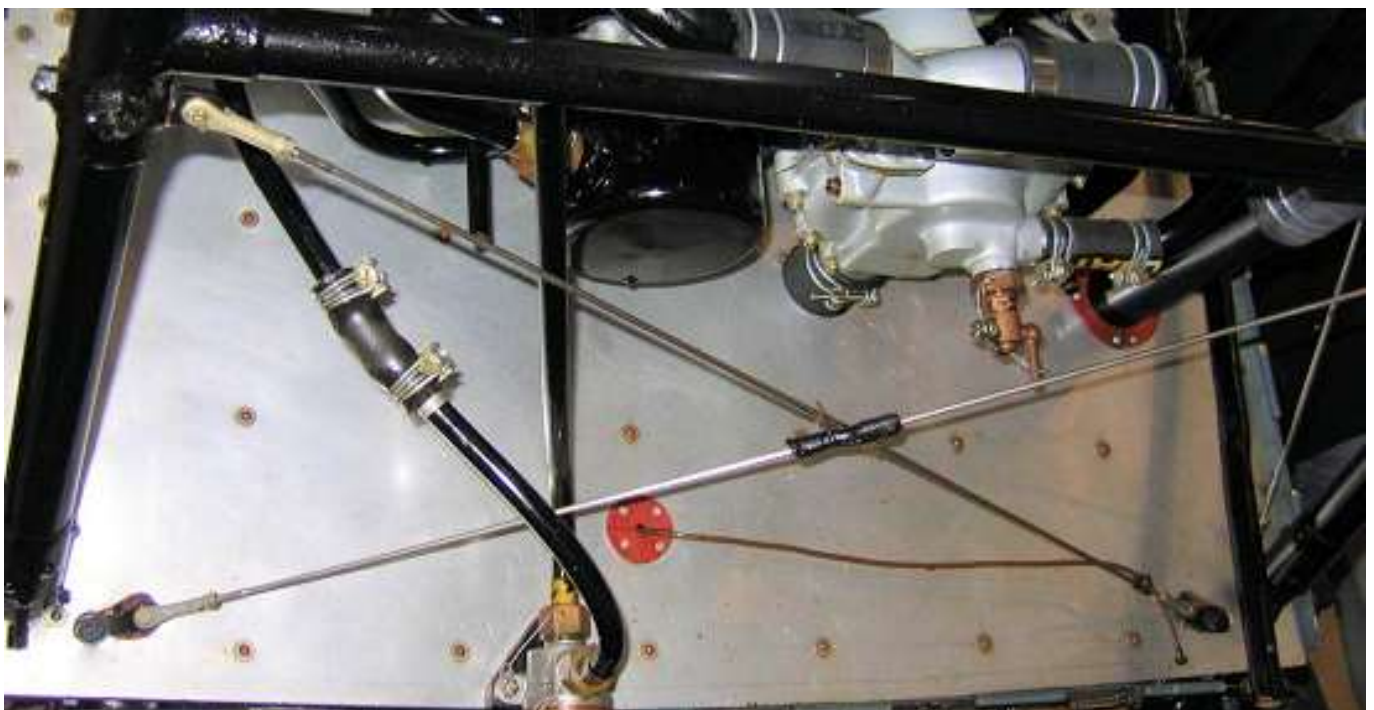
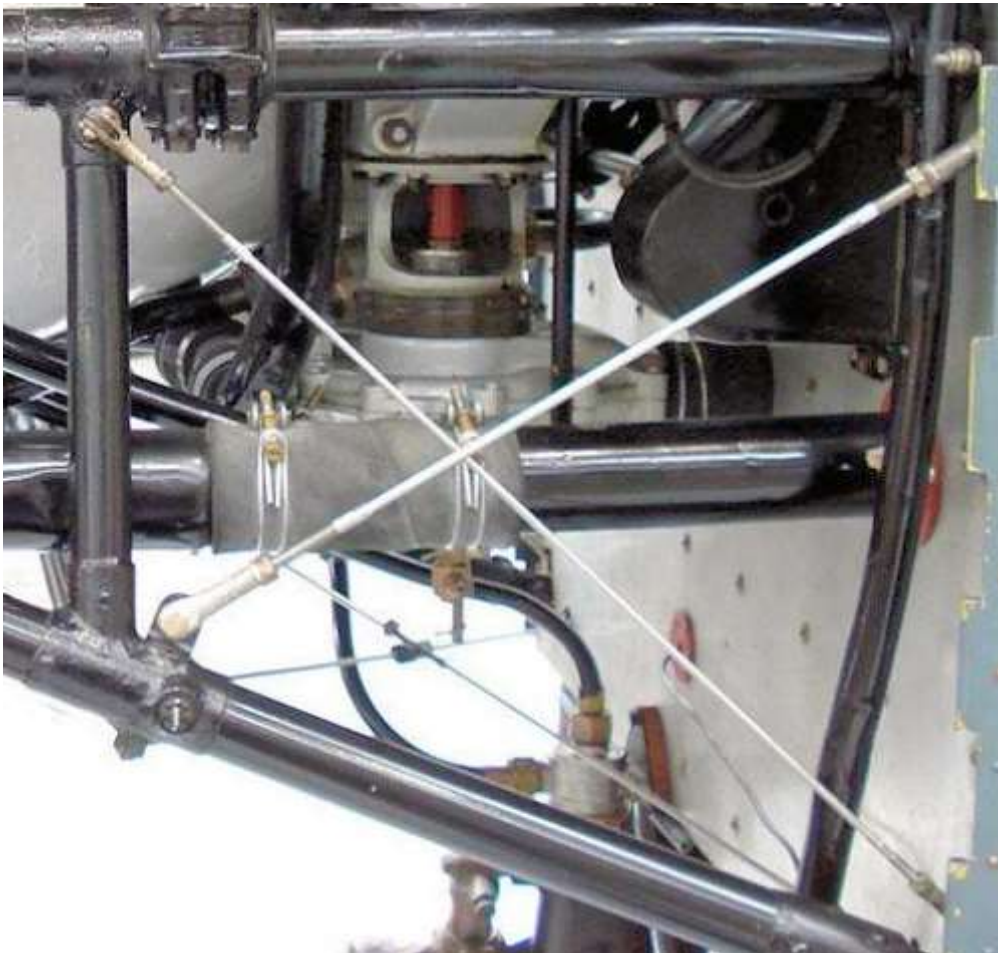

External rigging:

Elevator control cables:

Elevator control cables were attached to the ends of external levers at the cockpit sides. The dual cables were routed rearwards and crossed before being attached to the upper and lower control horns on the elevators. The ends of the elevator control horns were interconnected with single wires through the elevators. A turnbuckle was fitted in each control cable and over the tailplanes.

As the pilot moved the control column forwards or rearwards, the control levers rotated and pulled the elevators either up or down, causing the aircraft to climb or dive (pitch). The cables were the standard round wire wound type and visible turnbuckles were fitted into the cables before the elevator control horns.

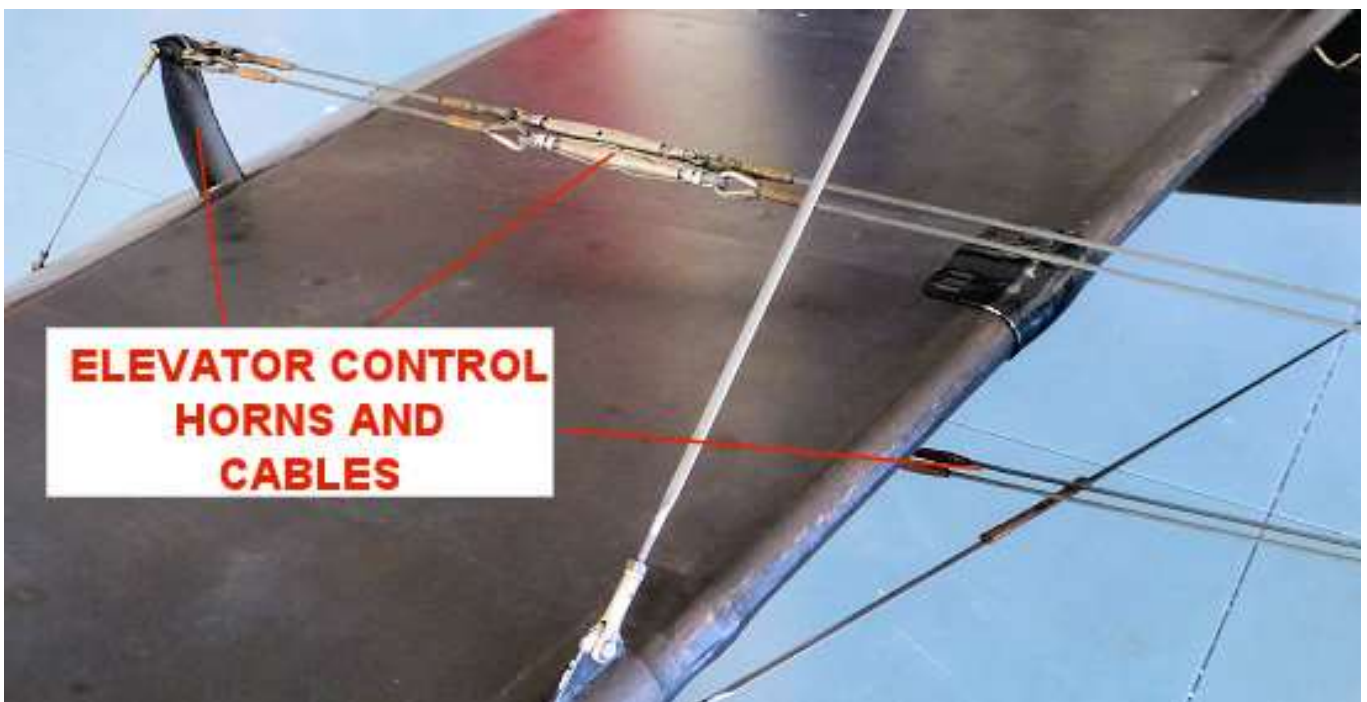
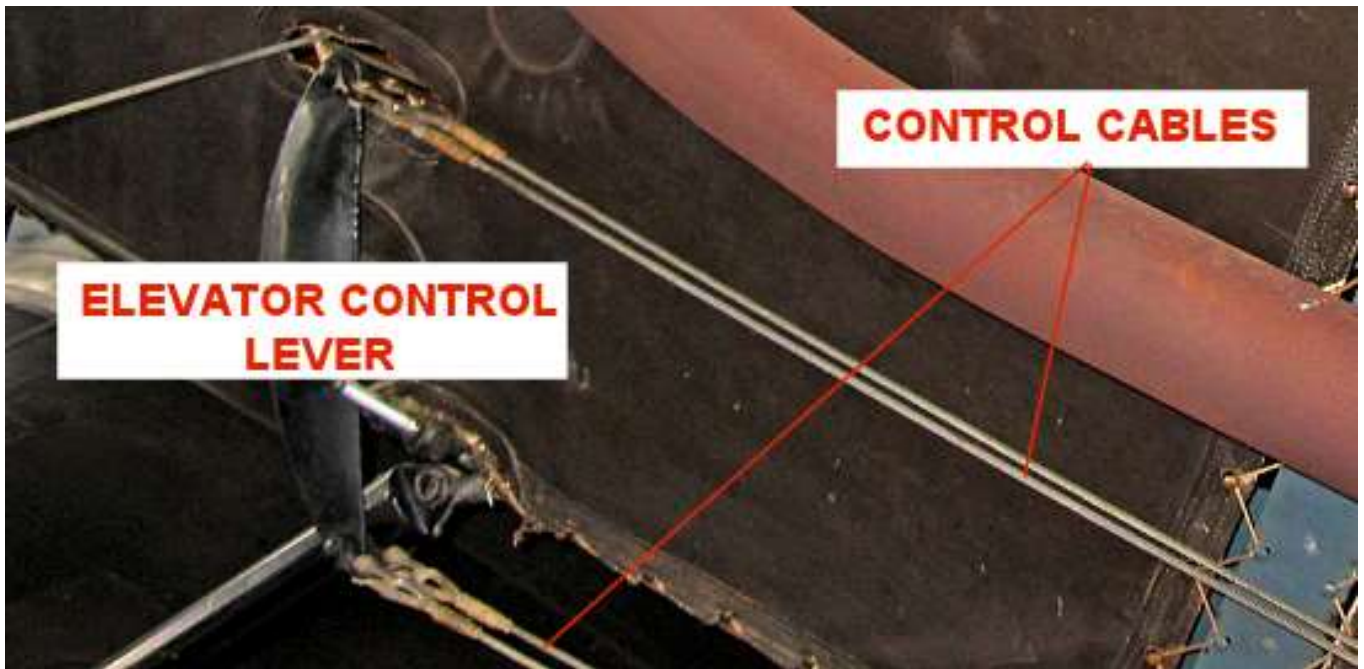

Rudder control cables:

A rudder control cable was looped around both ends of the pilots rudder bar to form dual control cables that were routed rearwards through the fuselage to exit at each side to be attached to the ends of the rudder control horn. The ends of the rudder control horns were interconnected with a single wire through the rudder. As the pilot moved the rudder bar left or right the cables would pull the rudder in the required direction, causing the aircraft to drift left or right (yaw).

The cables were the standard round wire wound type and visible turnbuckles were fitted into the cables towards the rudder.

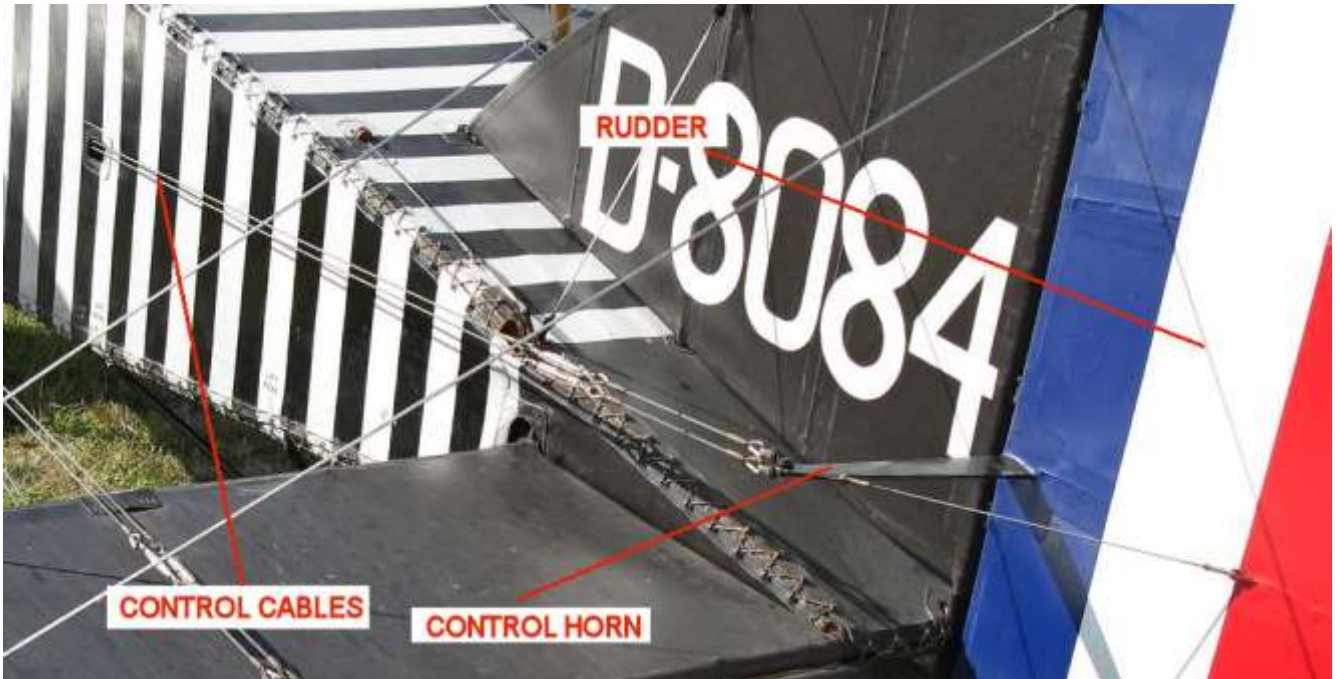

Aileron control cables:

An aileron control cable was attached to the left and right sides of the pilots control column. These cables were routed outboard through the sides of the fuselage then across the lower wings. The cables entered the lower wings close to the forward interplane struts and were routed rearwards and out the undersides to the bottom end of the aileron control horns. The cable was connected between the wings to both upper and lower aileron control horns. From the upper aileron control horn, the cables were routed forward and into and across the upper wing.

As the pilot moved the control column left or right the cables would pull both ailerons on one side of the aircraft in one direction and the opposite ailerons in the opposite direction, causing the aircraft to bank left or right (roll).

The cables were the standard round wire wound type and visible turnbuckles were fitted into the cables at the control column.

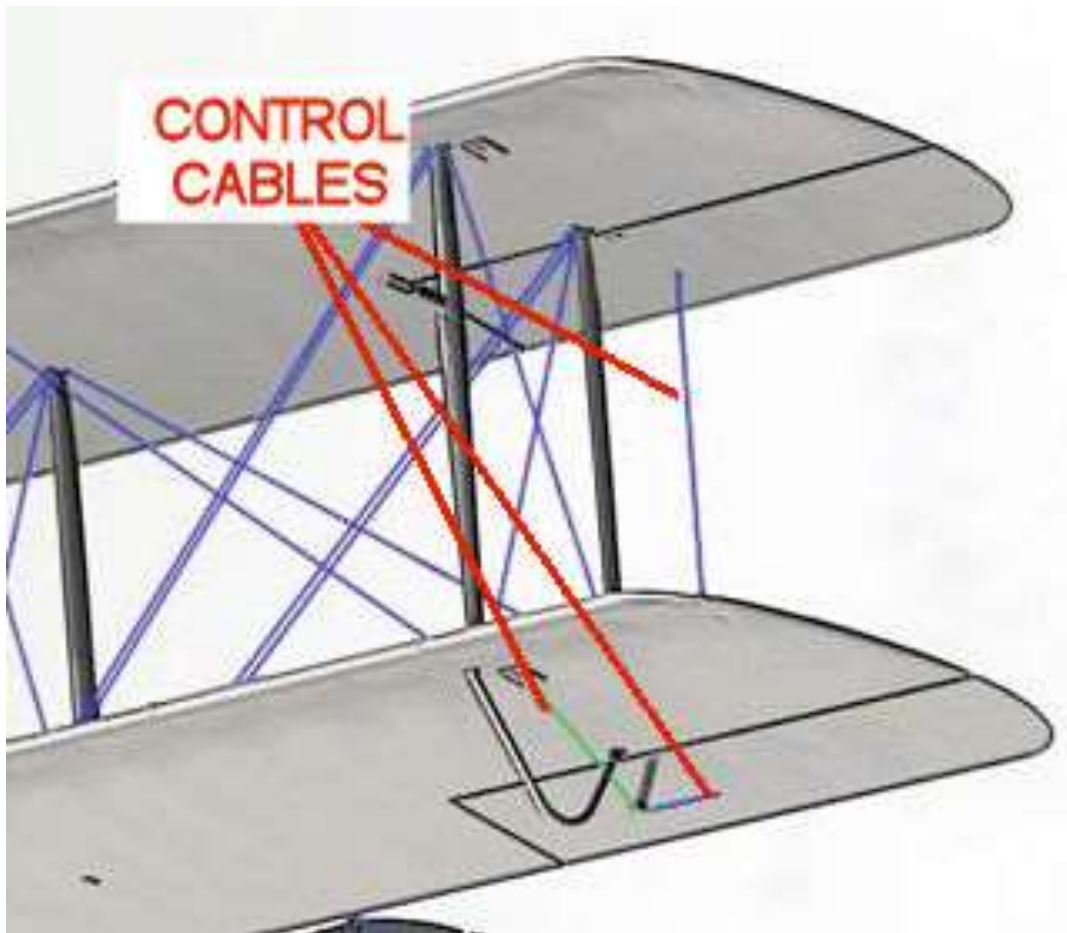
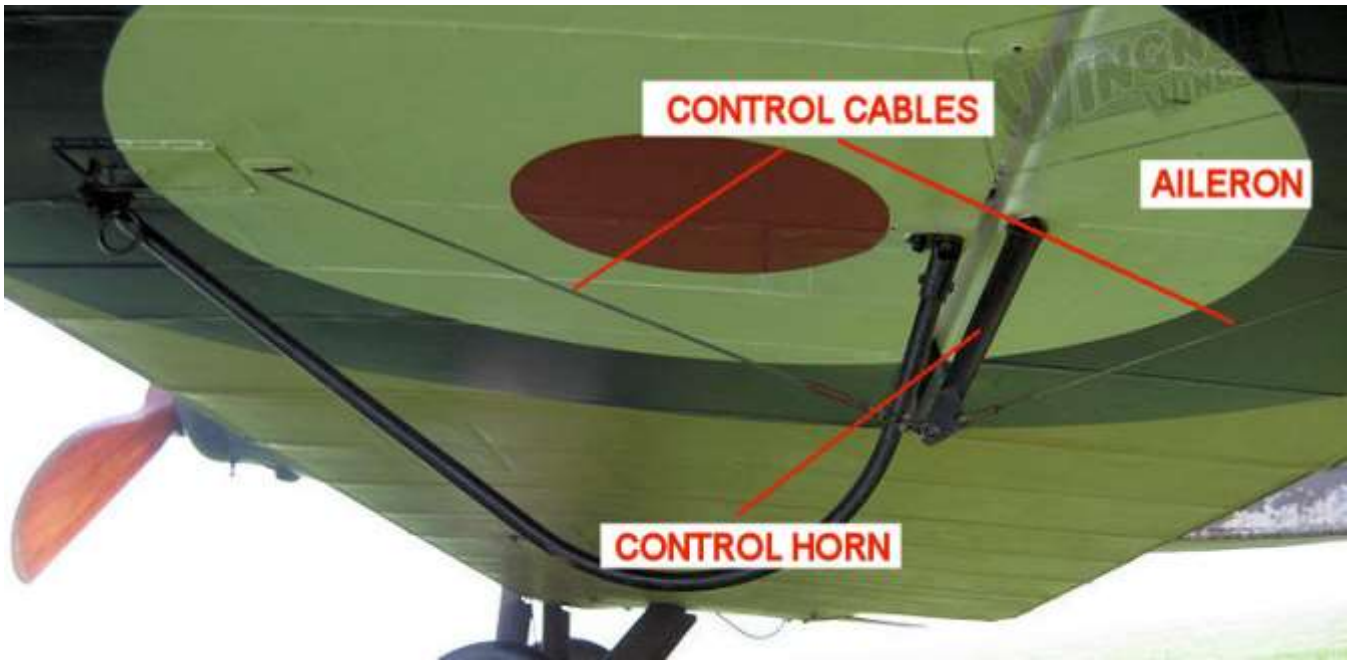

Tailplane incidence cable:

The angle (incidence) of the tailplane could be adjusted to alter the trim of the aircraft when in flight. A control lever was fitted in the top and bottom edges of the fuselage rear and were connected to the torsion bar of the of the tailplane (in the tailplane leading edge). These levers were attached to cables that were routed into the top and bottom sides of the fuselage and forwards to the cockpit adjusting lever on the right end of the fuel tank in the pilots cockpit. Turnbuckles were fitted into each cable at the control levers.



Flying wires:

Four pairs of streamlined flying wires were fitted to both sides of the aircraft and between the wings. These wires were fitted to restrain the upper wing when the aircraft was in flight.

Inboard pairs:

The forward pair were fitted between the top of the forward landing gear stuts and the underside of the upper wing, inboard from the forward inner interplane struts.

The rear pair were fitted between the bottom edge of the fuselage at the rear support strut for the lower wing and the underside of the upper wing, inboard from the rear inner interplane struts.

Outboard pairs:

The forward pair were fitted between the top surface of the lower wing outboard from the forward inner interplane struts and the underside of the upper wing, inboard from the forward outer interplane struts.

The rear pair were fitted between the top surface of the lower wing outboard from the rear inner interplane struts and the underside of the upper wing, inboard from the rear outer interplane struts.

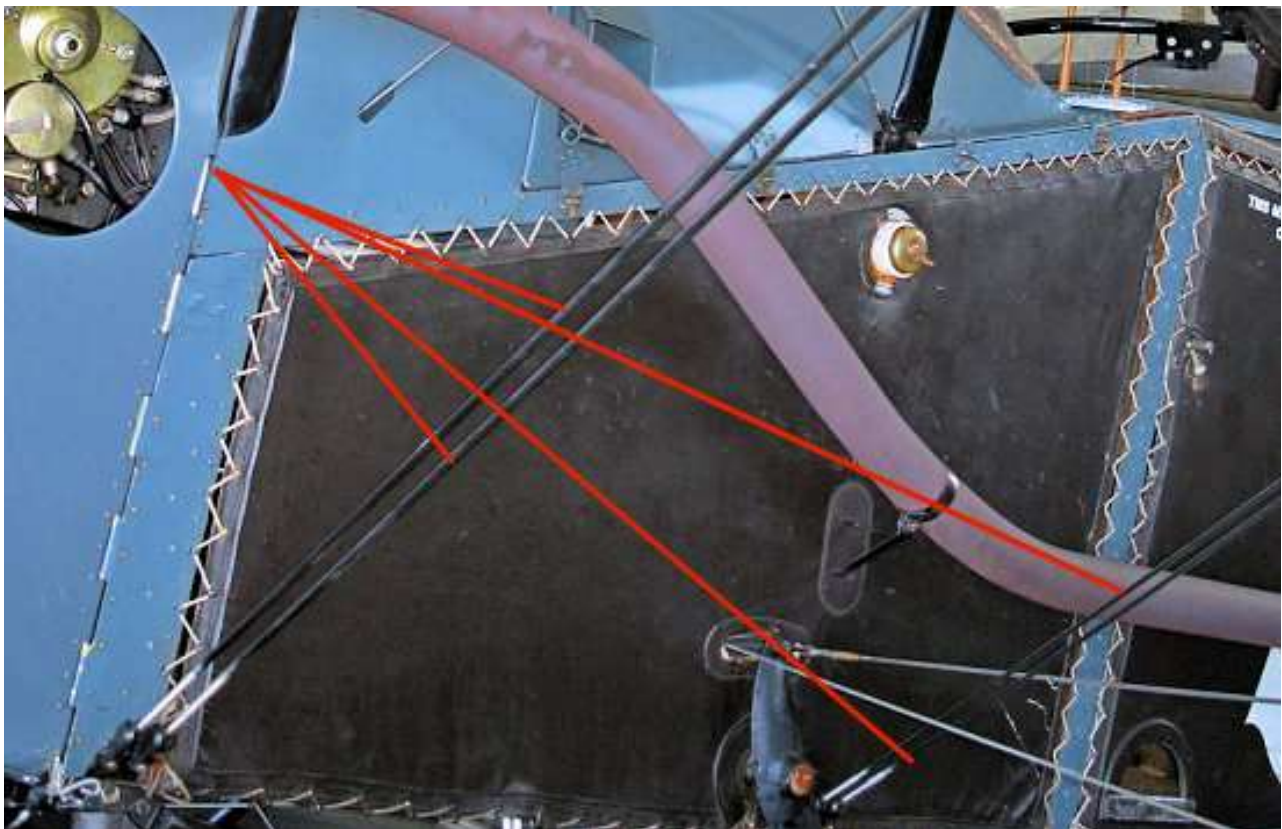
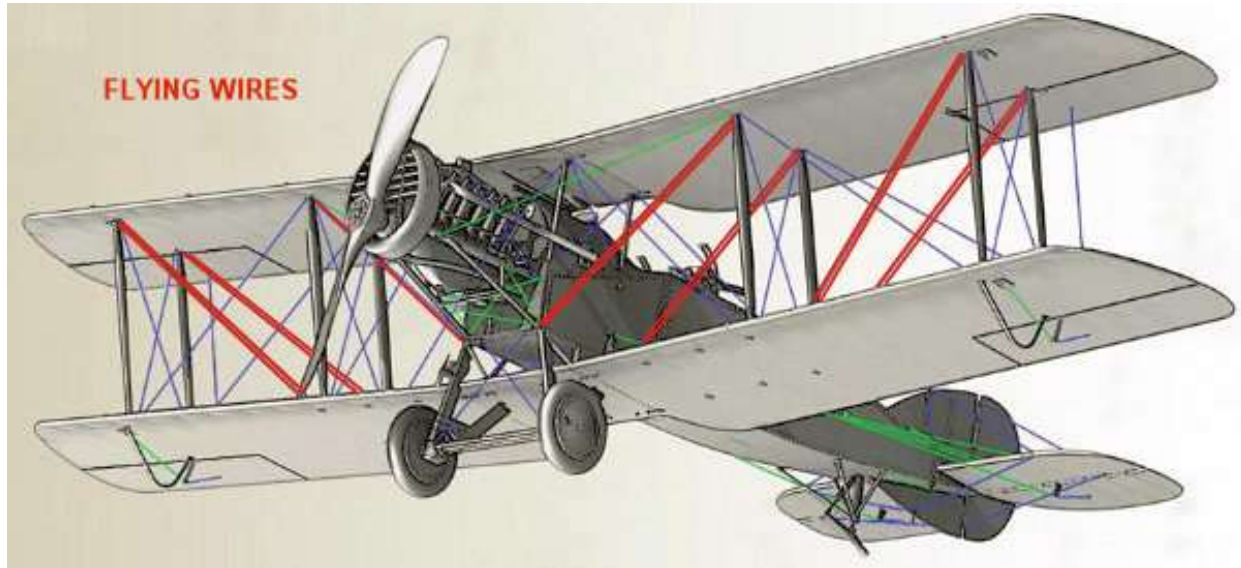



Landing wires:

Four single streamlined landing wires were fitted to both sides of the aircraft and between the wings. These wires were fitted to restrain the lower wing when the aircraft was in flight and on the ground.

Inboard wires:

The forward wires were fitted between the underside of the upper wing at the top of the fuselage forward cabane struts and the top surface of the lower wing, inboard from the forward inner interplane struts.

The rear wires were fitted between the underside of the upper wing at the top of the fuselage rear cabane struts and the top surface of the lower wing, inboard from the rear inner interplane struts.

Outboard wires:

The forward wires were fitted between the underside of the upper wing outboard from the top of the forward inner interplane struts and the top surface of the lower wing, inboard from the forward outer interplane struts.

The rear wires were fitted between the underside of the upper wing outboard from the top of the rear inner interplane struts and the top surface of the lower wing, inboard from the rear outer interplane struts.

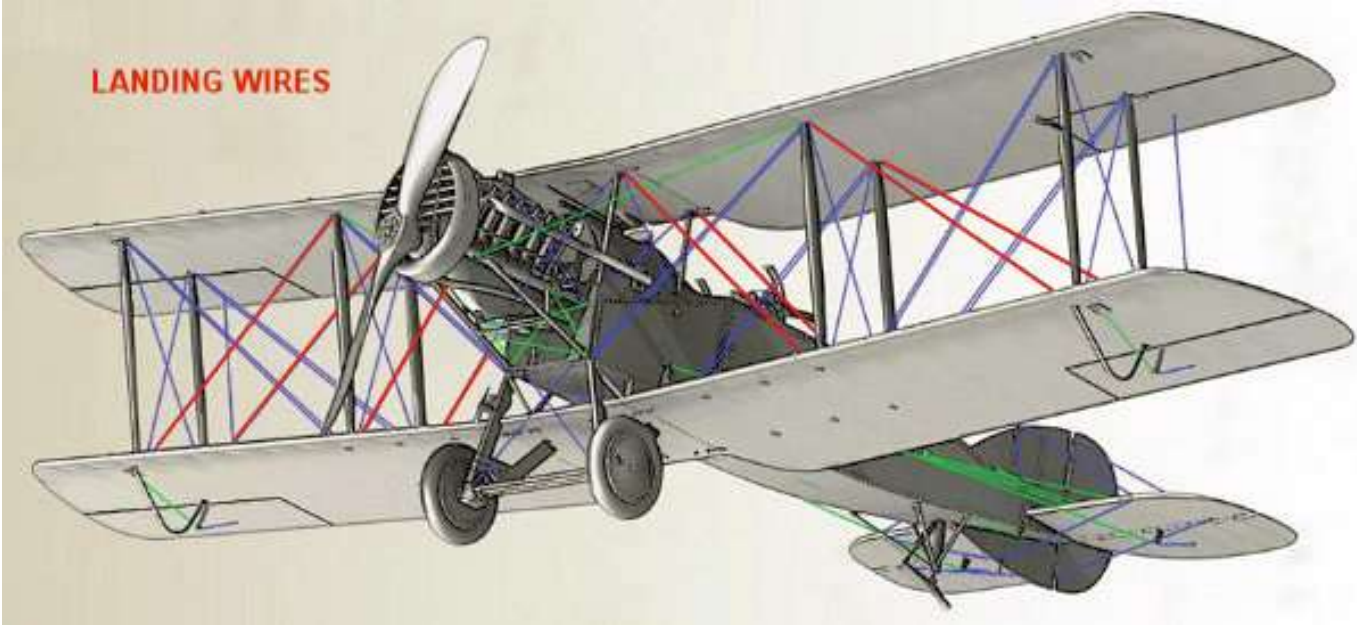

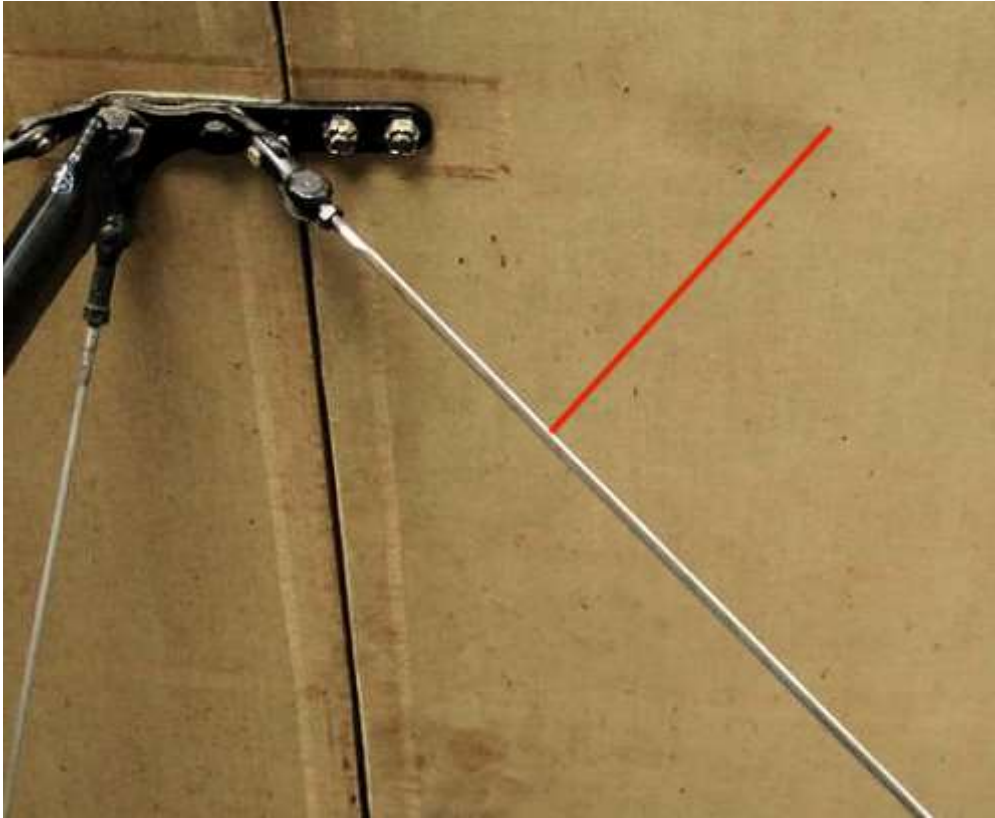

Cabane strut bracing wires:

Two single streamlined landing wires were fitted diagonally and crossed between the fuselage cabane struts on both sides of the aircraft. These wires were fitted to brace the cabane struts.

One wire was fitted between the underside of the upper wing at the rear of the fuselage forward cabane strut and forward from the bottom of the fuselage rear cabane strut.

The other wire was fitted between the underside of the upper wing forward from the fuselage rear cabane strut and forward from the bottom of the fuselage forward cabane strut (through a slot in the fuselage panel).

A third wire was fitted between the underside of the upper wing, inboard from the top of the fuselage forward cabane strut and down, through a panel opening, into the rear of the engine bay.

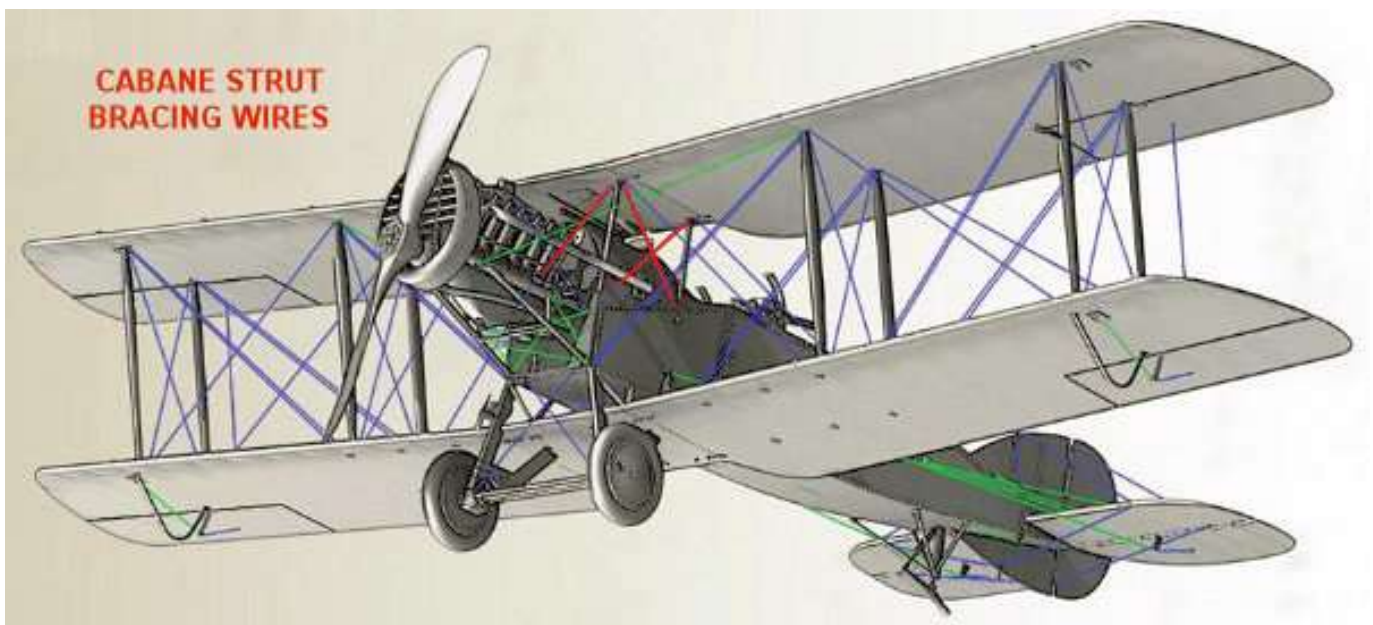

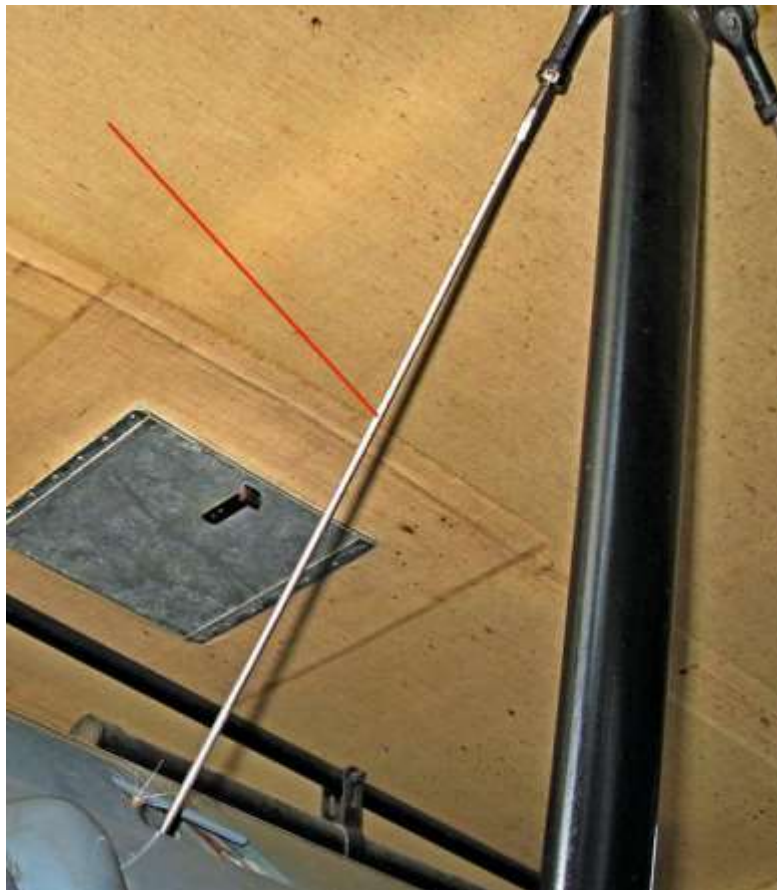
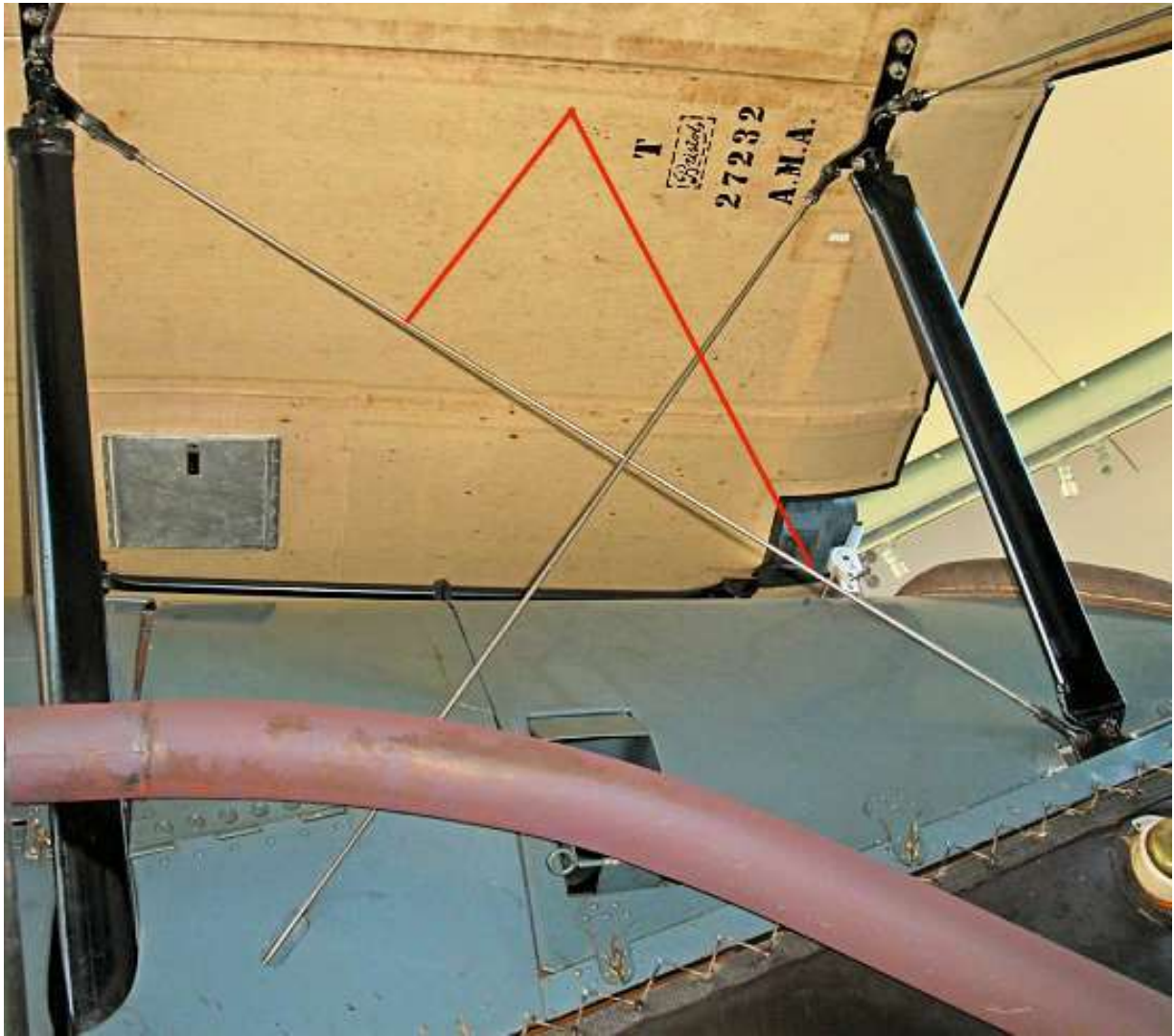

Landing gear bracing wires:

Two streamlined bracing wires were fitted between the underside of the fuselage, inboard from the landing gear forward struts and diagonally crossed and attached to the bottom of the opposite landing gear strut.

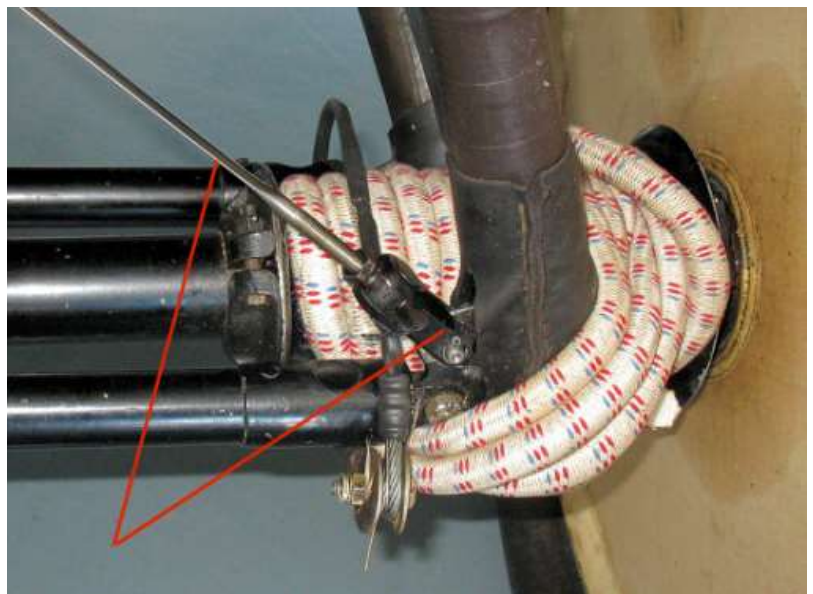
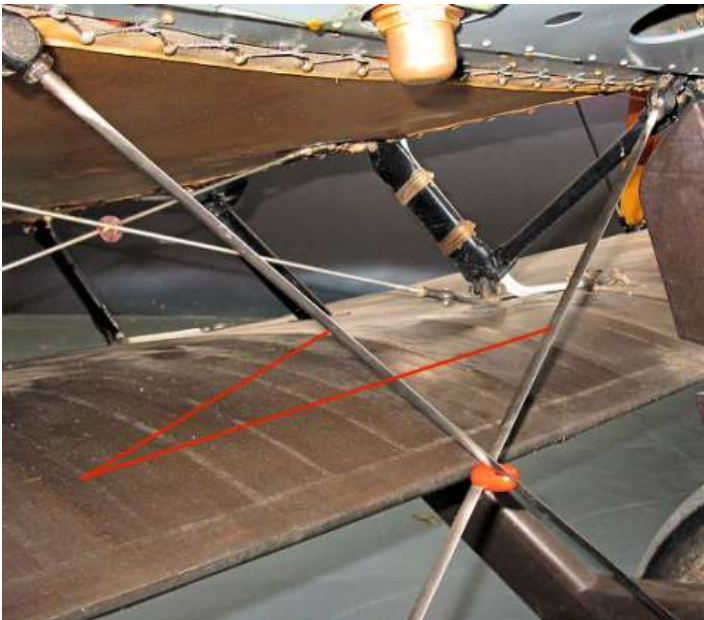
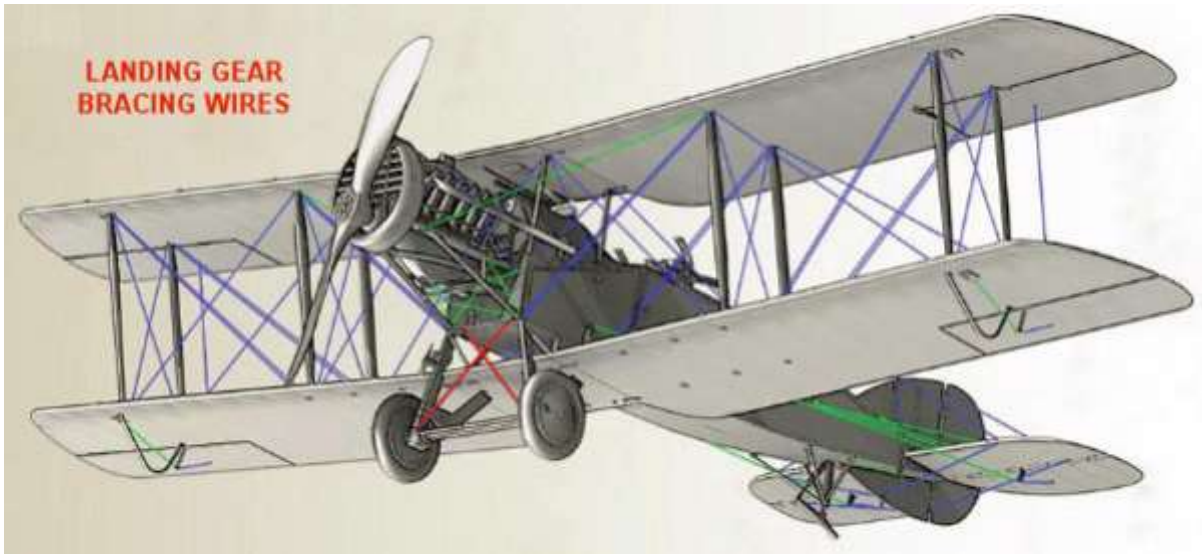

Lower wing bracing wires:

Two streamlined bracing wires were fitted between the underside of the fuselage and the lower wing. The wires were fitted between the underside of the fuselage at the top of the primary support strut for the lower wing and diagonally down to the bottom of the opposite support strut.

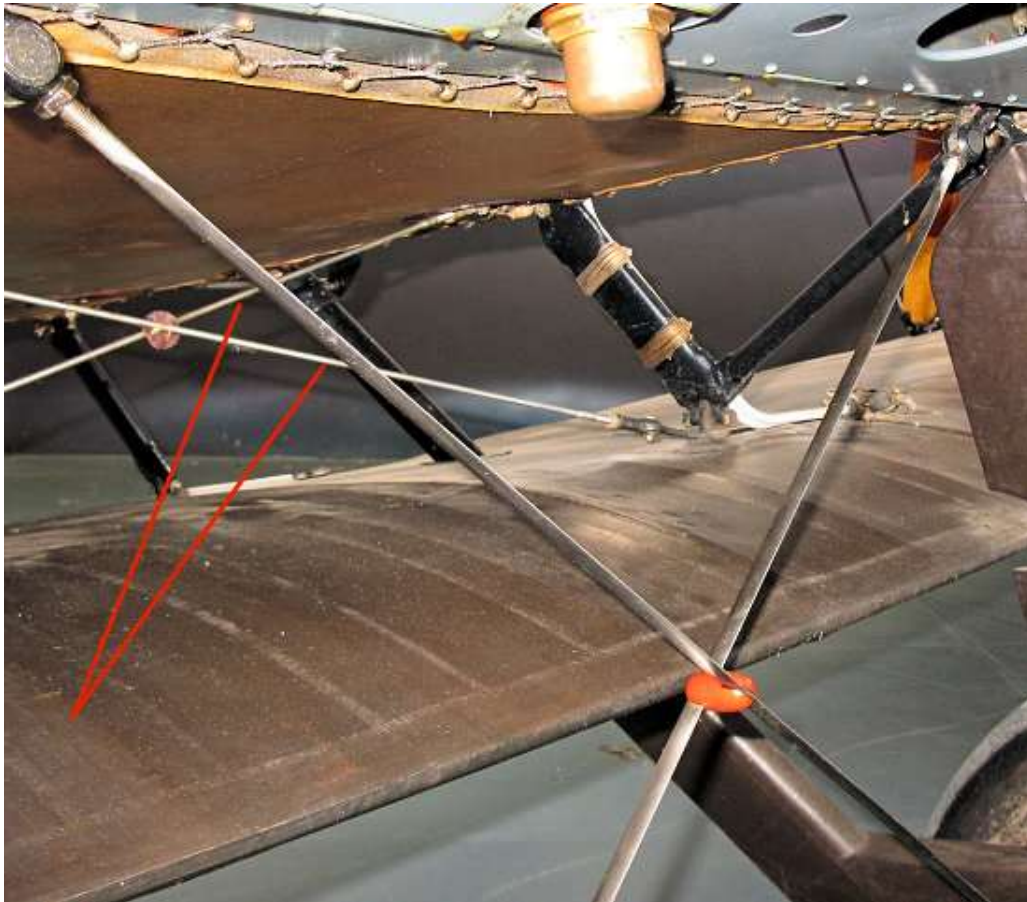

Incidence wires:

Two streamlined incidence wires were fitted, diagonally crossed, between the two pairs of interplane struts on both sides of the aircraft.

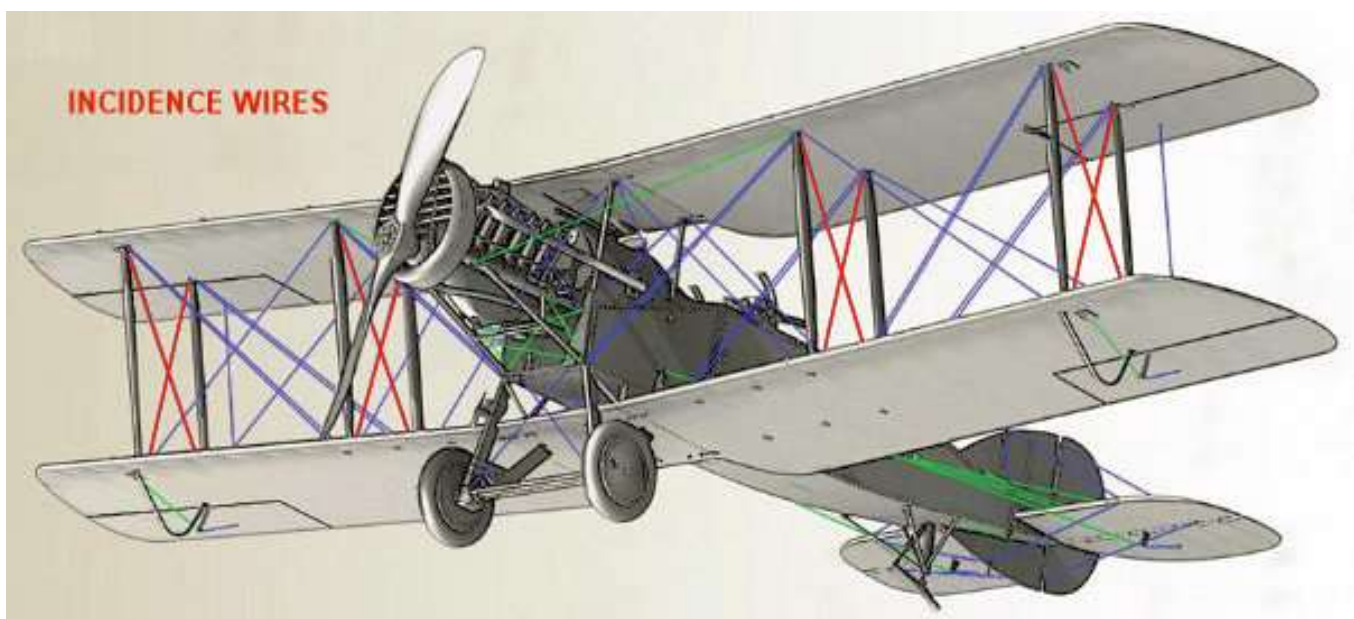

Inboard pairs:

A wire was fitted on the underside of the upper wing, at the rear of the forward inner interplane strut and the top surface of the lower wing, forward from the bottom of the rear inner interplane strut.

The other wire was fitted on the underside of the upper wing, forward from the rear inner interplane strut and the top surface of the lower wing, at the rear of the forward inner interplane strut.

Outboard pairs:

A wire was fitted on the underside of the upper wing, at the rear of the forward outer interplane strut and the top surface of the lower wing, forward from the bottom of the rear outer interplane strut.

The other wire was fitted on the underside of the upper wing, forward from the rear outer interplane strut and the top surface of the lower wing, at the rear of the forward outer interplane strut.



Tailplane bracing wires:

The tailplane was braced on both sides of the aircraft with four separate streamlined bracing wires supporting the leading edge of the tailplane and four supporting the trailing edge.

Forward wires:

A single streamlined bracing wire was fitted between a support on the top of the fin and the outer section of the top surface of the tailplane leading edge.

A second wire was fitted between the underside of the tailplane leading edge and the bottom edge of the lower, under fin.

Rear wires:

A single streamlined bracing wire was fitted between the top of the fin trailing edge and the outer section of the top surface of the tailplane trailing edge.

A second wire was fitted between the underside of the tailplane trailing edge and the lower section of the trailing edge of the lower, under fin.

Fin bracing wires:

The fin was braced with single streamlined bracing wires, which were fitted between the top edge of the fin and down the top outer edge of the fuselage.

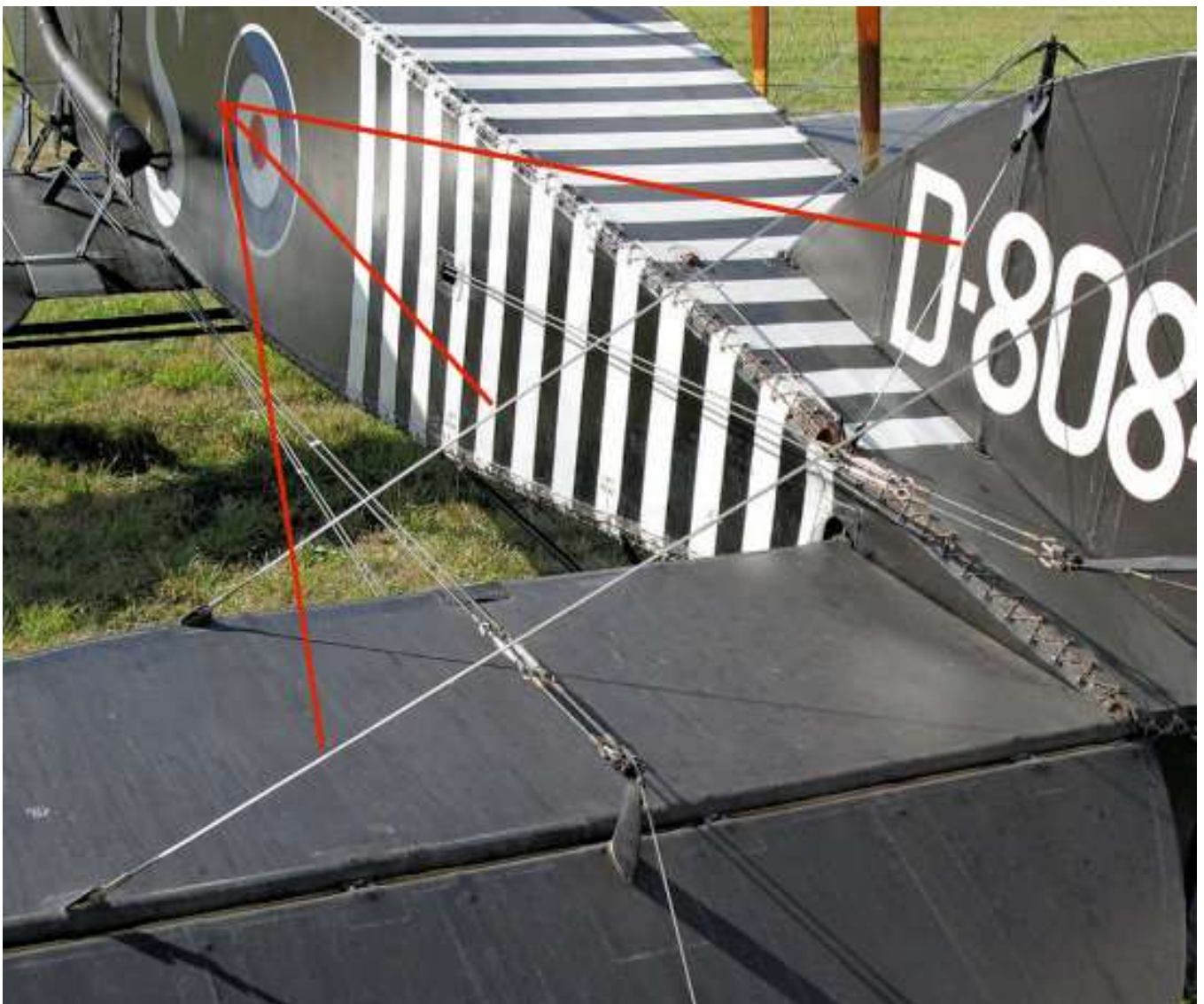

Drag wires:

A single drag wire was fitted to each side of the aircraft, between the underside of the upper wing, at the top of the forward, inboard interplane struts and through the open air scoop (on the forward, side of the engine side access panels) onto the front of the engine bearers. A turnbuckle was fitted to the wire at the engine bearers.

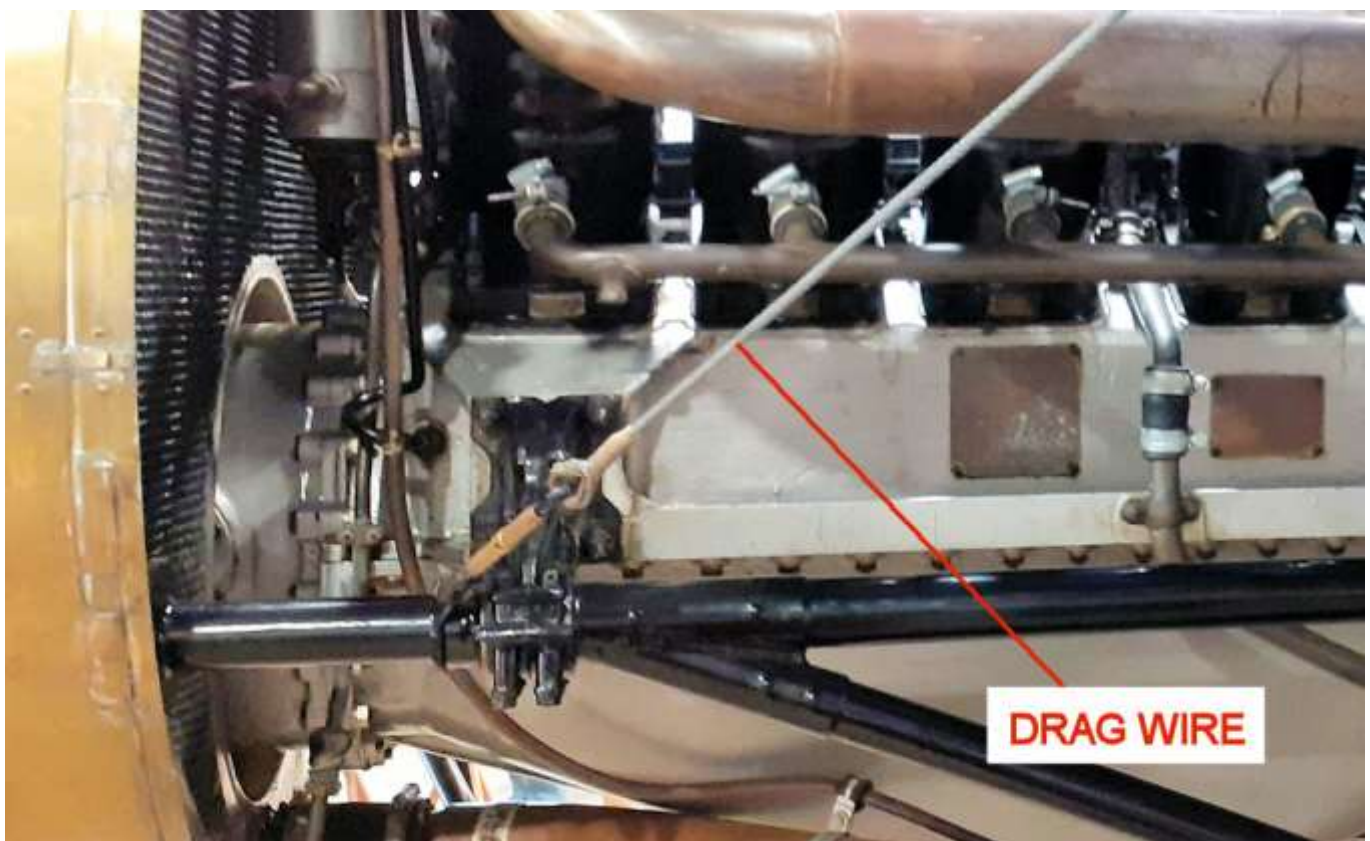
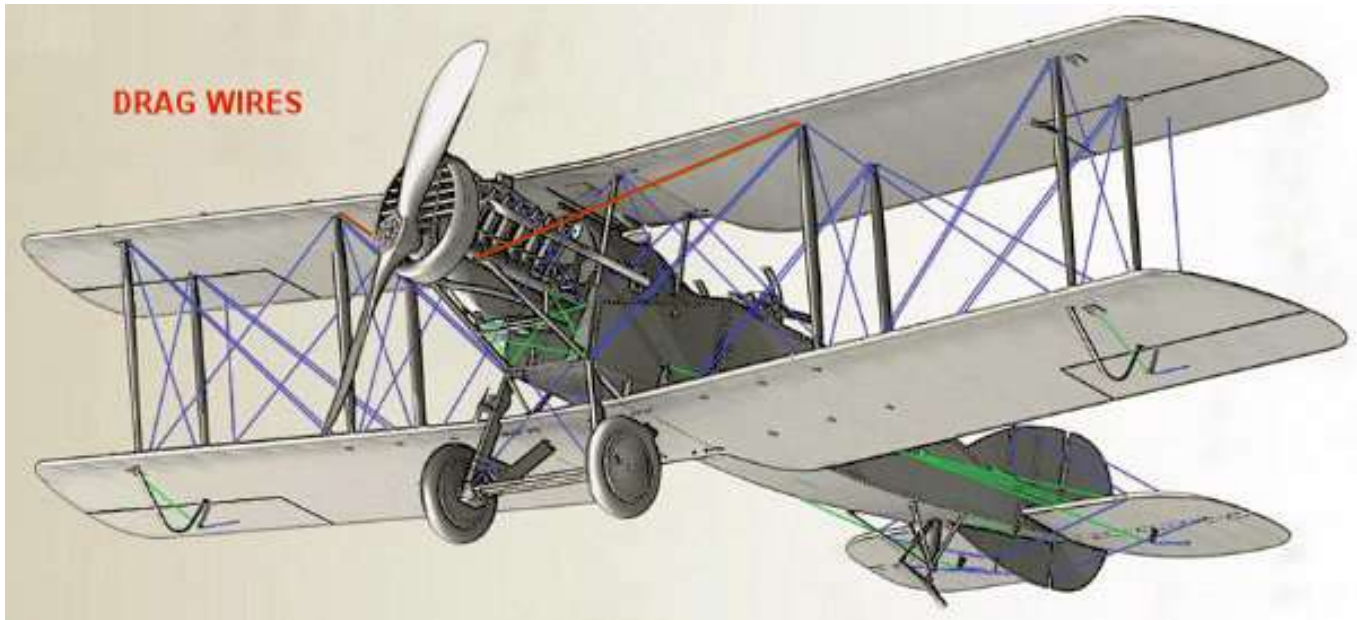

Radiator shutter control cables:

NOTE: *The radiator shutters were controlled by the pilot, using a lever inside the cockpit, routed through the side of the fuselage to a bell-crank. This was connected to the operating bell-crank located on the right side of the radiator cowl. The two were connected by two crossed cables.*

It seems probable that the radiator shutter control was fitted to these aircraft post WW1, as I found no evidence of them being fitted to this or other early Bristol F.2b aircraft.

*Therefore I chose **not to add the shutter controls** to this model*

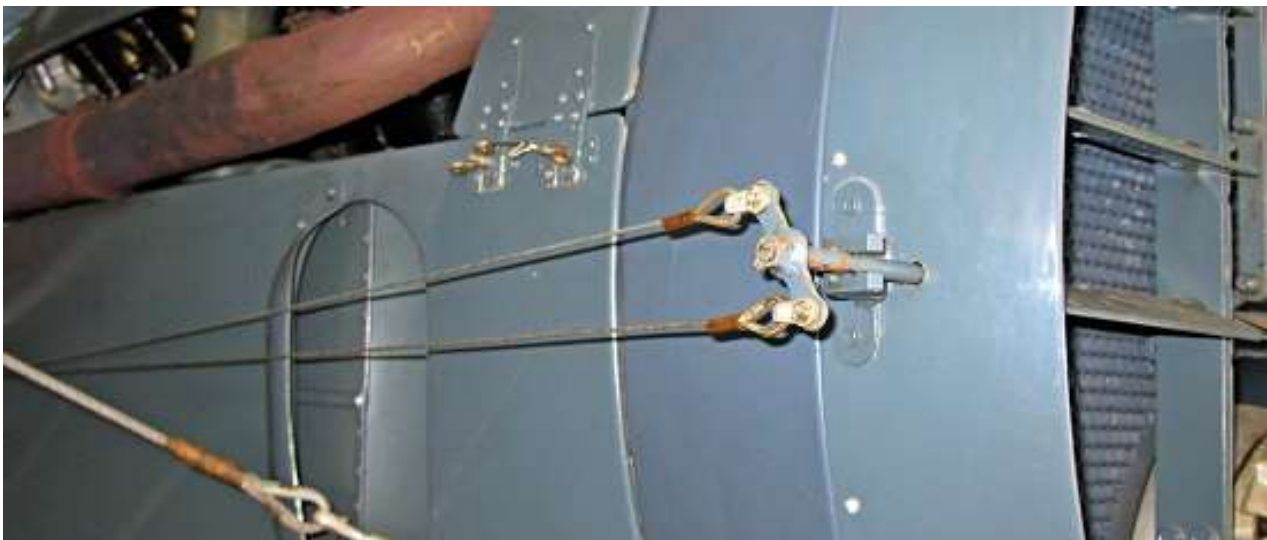
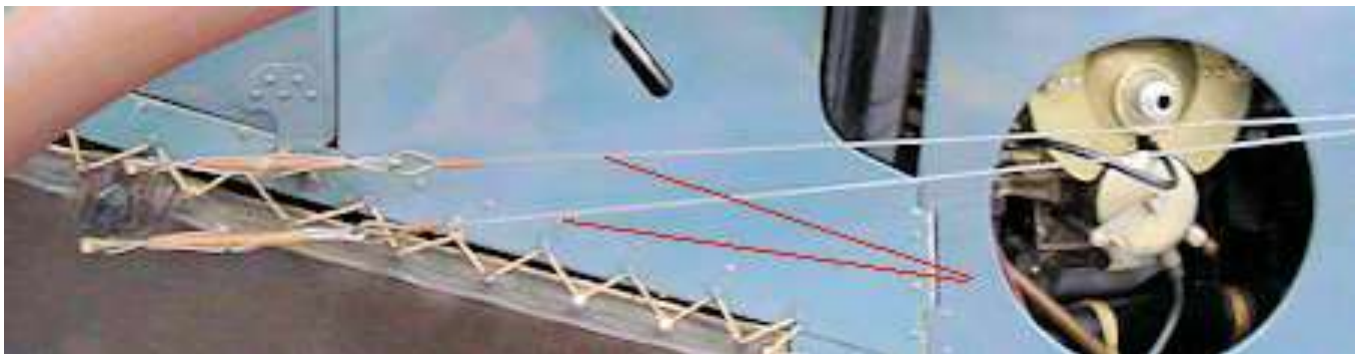
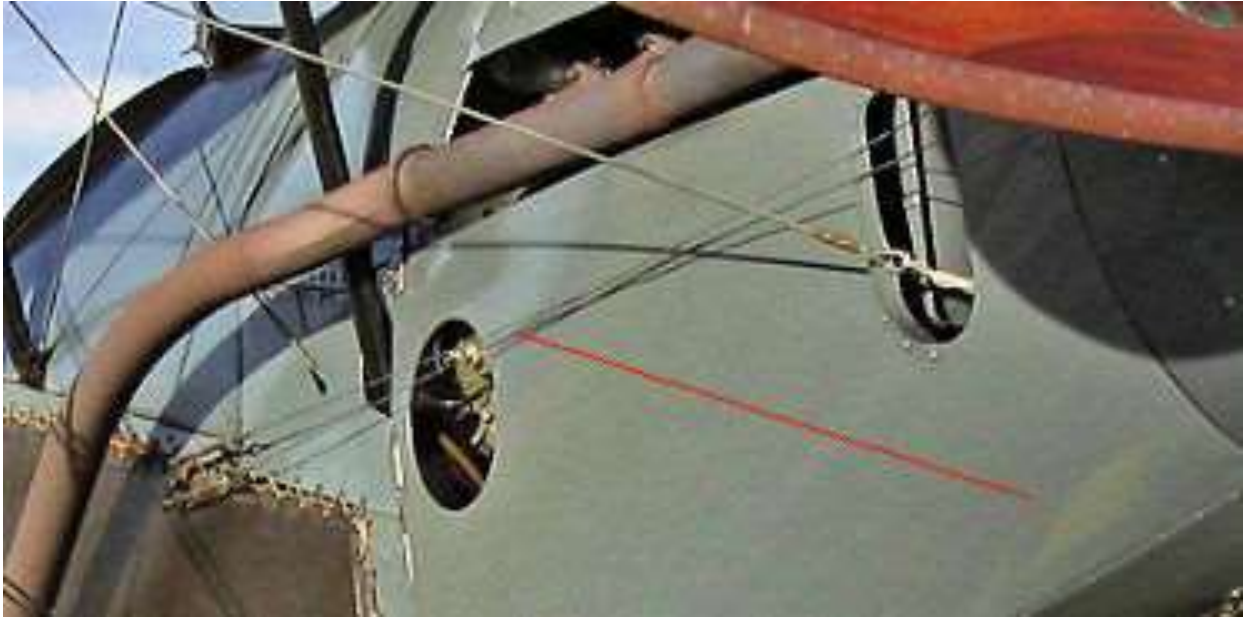

PART 7

BASIC ENGINE

PART 7 - BASIC ENGINE

The engine represented in the kit is of the **Rolls Royce 'Falcon' V12** in-line engine.

The 'Falcon' aero engine was developed in 1915. It was a smaller version of the Rolls-Royce 'Eagle' engine, a liquid-cooled V-12 of 867 cu in (14.2 L) capacity. Fitted to many British WW1 aircraft, production ceased in 1927. The 'Falcon' engine was designed by R.W. Harvey-Bailey. An airworthy 'Falcon' engine survives today and powers a Bristol F.2 fighter during summer Displays at the Shuttleworth Collection at Old Warden, Bedfordshire in the UK.

Production of the 'Falcon' engine began in September 1916 and was so successful that it was also manufactured under licence by Brazil Straker in Bristol. Production continued until 1927, by which time 2,185 'Falcon' engines had been built.

An unusual feature of this engine was the epicyclic propeller reduction gear which contained a clutch designed to limit the maximum torque, thus protecting the reduction gears. The 'Falcon' engine was notably used in the Bristol F.2 fighter and the Blackburn 'Kangaroo' bomber.

A very good reference for photographs of the Vintage Aviator Ltd Falcon engine can be found at the web site of James Fahey.

<https://jamesfahey.smugmug.com/Rolls-Royce-Falcon-engine/>



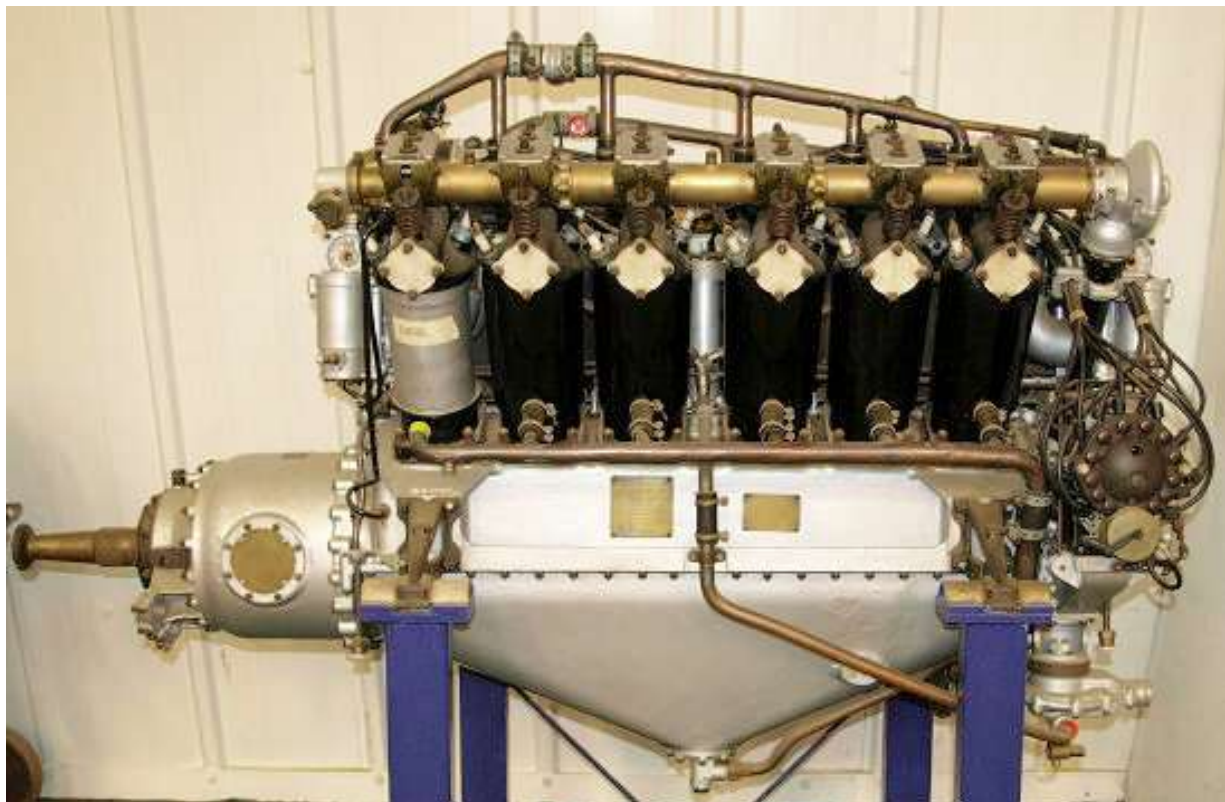

Although the kit supplied engine is of good quality and detailed, there are enhancements that can be added to make the engine look more authentic. Details such as ignition leads, pipes etc. Such enhancements are covered in this Part of the build log.

NOTE: *When cementing large kit parts, I use 'Revell' Contacta Professional cement (39604). This is a thicker liquid cement, which takes longer to fully set, but does provide a stronger bond between larger kit parts. 'Tamiya' liquid cement is used for smaller parts.*

Before working with or cementing model parts together, make sure all mould seams, sprue tags, mould 'flash', paint or primer is removed from each part.

Refer to the relevant pages in the kit instruction manual.

Assembly:

Cement the two halves of the crankcase (E19, E20) together.

Cement the two halves of the left cylinder bank (E2, E4) and right bank (E1, E3) together.

Cement the propeller shaft (E13) into the bell housing (E15).

Cement the bell housing assembly onto the front of the crankcase assembly.

Cement the air induction filters (E16, E17) into the carburettor housings (E18).

Painting:

Airbrush all of the engine parts with a black primer, such as 'AK Interactive' Black (AK757) or similar.

Airbrush the engine crankcase assembly and the four induction manifolds (E6) with 'Alclad' Duraluminium (ALC102) or similar.

Airbrush the two camshafts (E5) with 'Alclad' Pale Gold (ALC108) or similar.

Airbrush the drive housing (E20), water pump (E9) and the two carburettor housing assemblies with 'Alclad' Steel (ALC112) or similar.

Brush paint the following parts:

'Tamiya' NATO Black (XF69) or similar:

Nose plate on the bell housing, the four engine bearers, oil filter, the two magneto bodies, the two magneto drive shafts.

'Tamiya' Neutral Grey (XF53) or similar:

The four induction air filters (E16, E17).

'Mr. Colour' Copper (215) or similar:

The four air supply pipes on top of the carburettors (E18).

'Mr. Colour' Brass (219) or similar:

Magneto faces and switch cylinders (E24, E25), oil filler cap on the top of the crankcase pipe.

'Mr. Colour' Stainless Steel (213) or similar:

Camshaft cover plates and valve springs on the top of the cylinder banks.

Assembly (continued):

Cement the drive housing assembly (E20) onto the rear of the engine crankcase assembly.

Cement the oil filter (E9) onto its location at the bottom of the drive housing (E20).

Cement the water pump (E9) onto its location at the bottom of the drive housing (E20).

Cement the Magneto faces and switch cylinders (E24, E25) onto the Magnetos on the drive housing (E20).

Cement the carburettor assemblies (E18) into their locating slots in the engine crankcase.

Cement the four induction manifolds (E6) into their locating holes in the cylinder heads and the two carburettor assemblies.

Cement the two pipes (E8, E11) into their location holes at the four induction manifolds (E6).

Cement the pipe/valve (E14) into its recess in the engine crankcase.

Cement the two coolant pipes (E7, E19) into their locating holes in the cylinder banks and onto the locating flats on the fitted water pump (E26).

Cement the pipe (E12) into its locating hole in the side of the engine crankcase and against the body of the fitted water pump (E26).





Enhancements:

Ignition leads:

NOTE: *The magnetos on each side, at the rear of the engine, have twelve ignition leads each. These are connected as pairs to the two spark plugs on each of the six cylinders on that side of the engine. In total there were twenty four ignition leads from the two magnetos.*

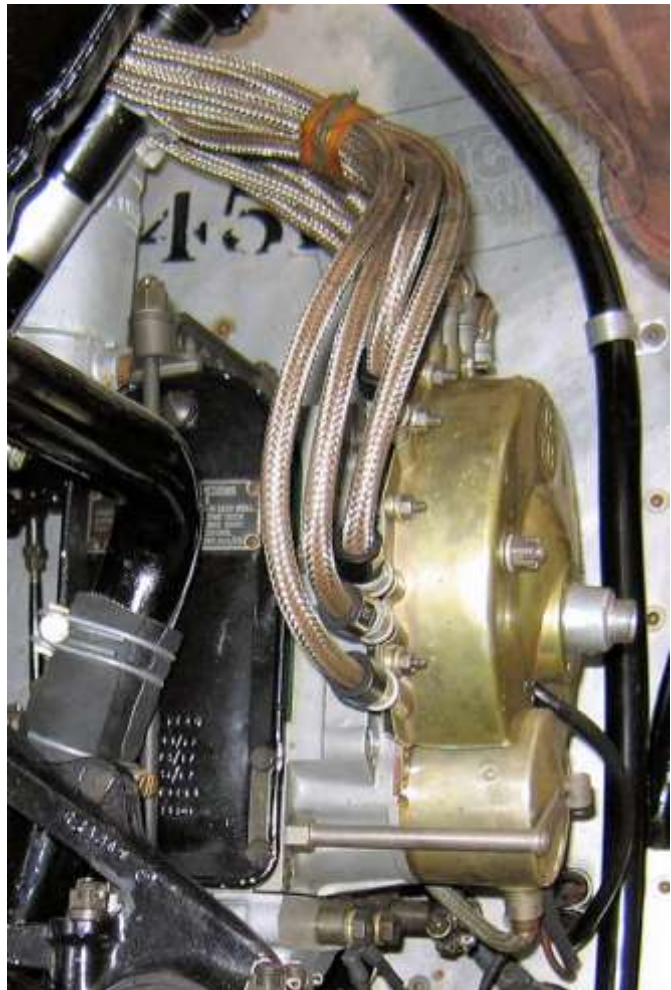

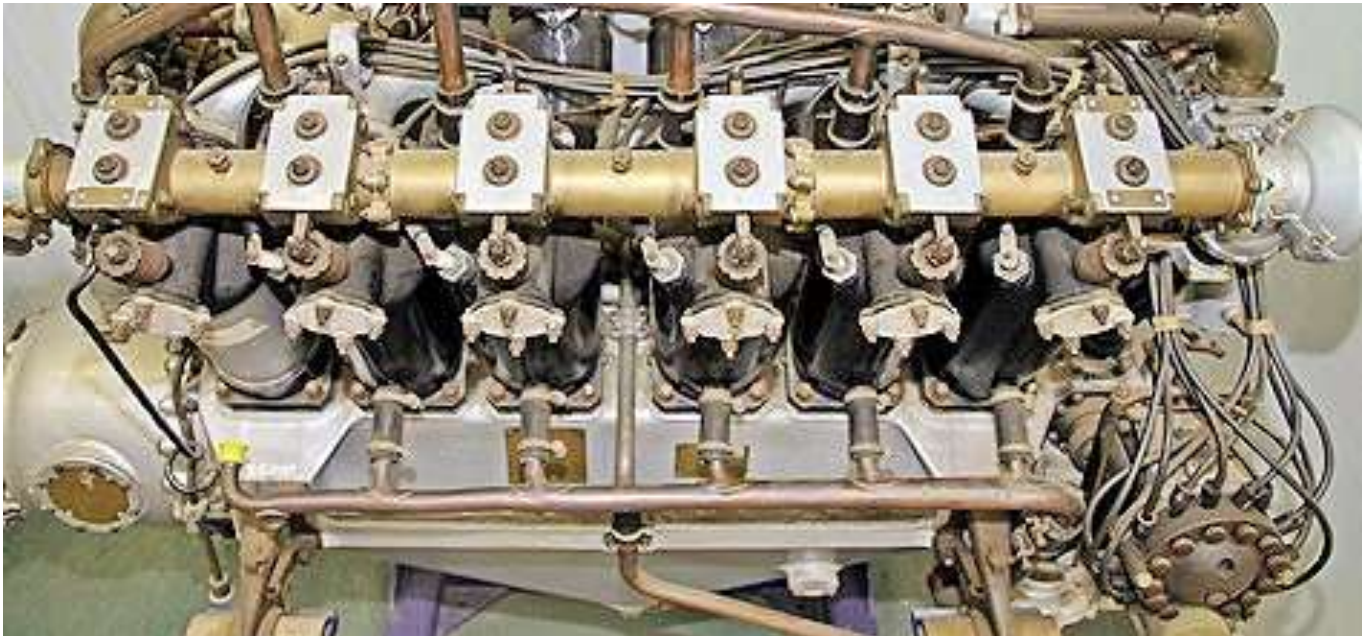

To create the ignition leads I used 'YLI' silk thread #100. This does not have the loose threads of cotton, but is as flexible, which is needed due to the amount of leads required.

Drill twelve holes of 0.4 mm diameter into and equally spaced around the edge of the faces of the two magnetos.

NOTE: *Thin CA adhesive is **only** used to seal the ends of the silk threads together and **not** to secure the threads into the magnetos, as the adhesive will spread up the thread causing it to become hard and rigid. The threads need to be flexible at the magnetos to enable them to be curved up to the engine.*

Cut twenty four long lengths of 'YLI' silk thread #100 (225).

Dip one end of each of the threads into thin CA adhesive (to seal the thread together).

Cut the sealed ends on the threads to leave approximately 1.0 mm.

Using a PVA adhesive, such as 'Microscale' Micro Kristal Clear, secure the sealed end of each thread into a pre-drilled hole in the edges of the two magnetos.

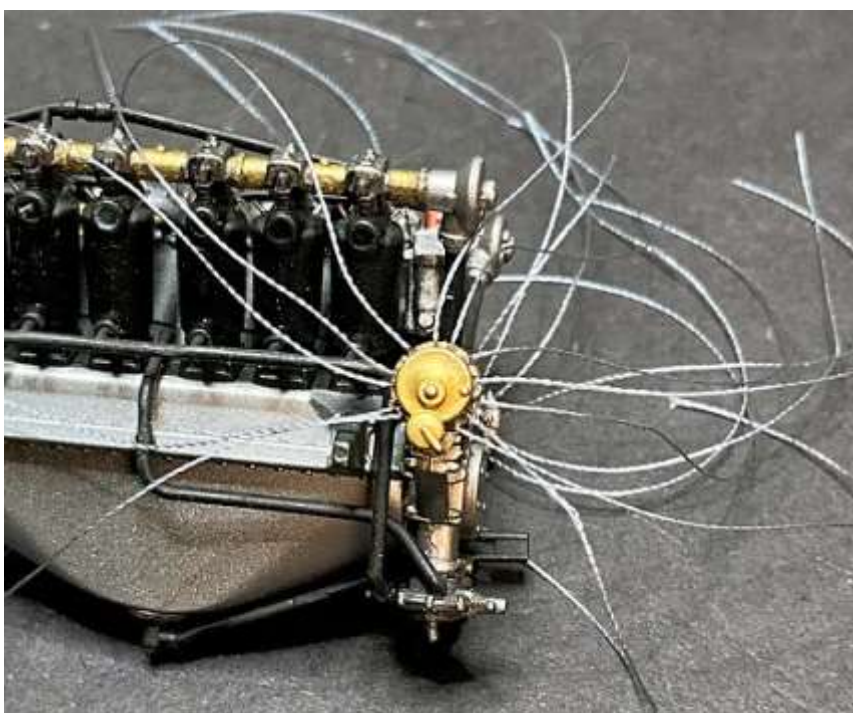

NOTE: *The following procedure is applicable for both sides and magnetos of the engine.*

Pass the six ignition leads (on the right side of the magneto) up and around the top, rear of the magneto drive shaft.

Pass the six ignition leads (on the left side of the magneto) up to the top, front of the magneto drive shaft.

Cut a length of thread and pass it around the twelve leads and tie them to the drive shaft, making sure the twelve leads are looped up from the magneto and not straight and under tension.

Secure the tied leads to the drive shaft using either PVA or thin CA adhesive.

Cut away the end tags of the tie-off thread.

Magneto - right side leads:

Pass one of the leads forwards over the two induction manifolds then around the front of the coolant pipe on the front cylinder.

Using thin CA adhesive, secure the lead to the added front spark plug of that cylinder.

Cut away the end tag of the lead as close as possible to the spark plug.

Repeat the procedure to attach the remaining five leads to the remaining five engine cylinders.

Repeat the procedure to attach the six leads to the opposite six engine cylinders.

Magneto - left side leads:

Repeat the procedure to attach the six leads on each side of the engine, to the six rear spark plugs of the engine cylinders, passing each lead around the rear of the coolant pipe on each cylinder.

Finish:

To darken the threads and harden them in position, apply by brush thin CA adhesive onto the threads and allow the adhesive to 'wick' along the threads.

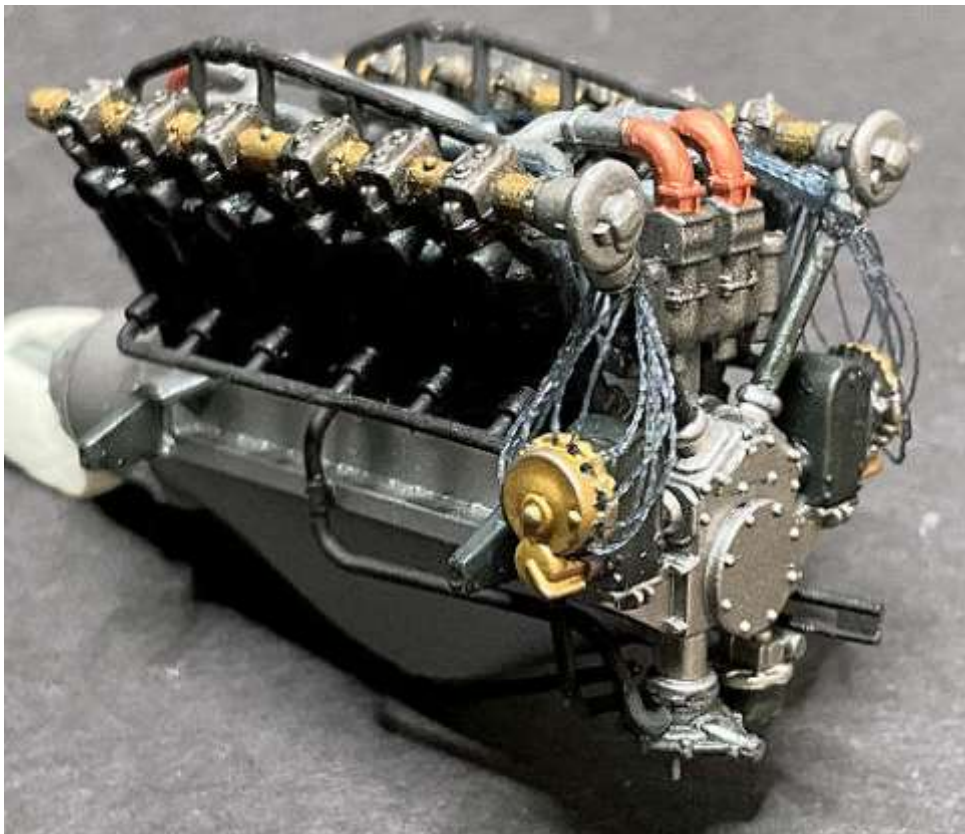



NOTE: *There are photographs of the exposed engine of the Bristol F.2b at the 'Shuttleworth' collection at Old Warden, Bedfordshire, UK. This Bristol F.2 Fighter F.2B D8096 was built in 1918, but did not see war time service. This aircraft was fitted with the later Rolls-Royce 275hp Falcon III engine and has different engine cowl panels and exhaust. Therefore, it's not the specific version that is being modelled.*

Another good source of photographs are those from 'James Fahey' of the Bristol F.2b at the 'Vintage Aircraft' in New Zealand. This aircraft is externally similar to the aircraft being modelled, but it's unclear as to which version of the Rolls-Royce' Falcon engine is fitted.

As it's difficult to be certain of the various pipe installations on the engine, I chose to fully enclose the engine, but leave open the upper, right access panel. Doing this will mean many of the various pipes will not need to be added as they will not be seen, only those visible at the upper right of the engine.

Carburettor/Magneto control rods:

NOTE: *The rear of the engine was fitted with control rods for the carburettors and magnetos. These would have been linked to the pilots throttle controls. Although this area of the installed engine is barely visible, I chose to represent basic carburettor and magneto control rods.*



Drill a hole of 0.4 mm diameter into the sides of the round cover plate at the lower, rear of the engine as show in the above photograph.

Cut two lengths of 0.3 mm diameter Nickel-Silver tube, such as 'Albion Alloy's' (NST03) or similar.

Bend one end of each tube to 90 degrees.

Cut the straight end of the tubes such that they can be inserted into the pre-drilled holes in the round cover plate with the bent ends against the pre-moulded lever on the bottom of both of the magnetos.

Using thin CA adhesive, secure the two tubes in position.

Cut a length of 0.3 mm diameter Nickel-Silver tube, such as 'Albion Alloy's' (NST03) or similar.

Cut the length of the tube such that it will position across the top of the triangular cover plate (above the round cover plate) with its ends protruding past into the gaps between the sides of the rear housing of the engine and the rear of the magnetos.

Using thin CA adhesive, secure the tube in position.

Cut two lengths of 0.2 mm diameter Nickel-Silver tube, such as 'Albion Alloy's' (NST02) or similar.

Bend one end of each tube to 90 degrees.

Cut the straight end of the tubes such that they can be position between the previously fitted tubes, with the bent ends against the ends of the top tubes and the straight ends on the lower tubes.

Using thin CA adhesive, secure the two tubes in position.

Cut two lengths of 0.2 mm diameter Nickel-Silver tube, such as 'Albion Alloy's' (NST02) or similar.

Cut the length of the tubes such that they will position against the inner edges of the top of the carburettors with the opposite ends against the top, horizontal tube.

Using thin CA adhesive, secure the tube in position and parallel to each other.

Brush paint 'Mr. Colour' Brass (219) or similar at the joints of each tube (to represent couplings).

Fuel supply pipes:

NOTE: *The outer sides of the carburettor float chambers have fuel supply pipes fitted. These pipes are joined centrally at the rear of the engine to a single pipe, which is routed down and forwards at the right side of the engine.*



Drill a hole of 0.4 mm diameter into the pre-moulded stub on the bottom, outer sides of the two float chambers.

Cut a long length of 0.3 mm diameter Brass tube, such as 'Albion Alloy's' (MBT03) or similar.

Cut a short length of 0.5 mm diameter Brass tube, such as 'Albion Alloy's' (MBT05) or similar.

Slide the short tube onto the 0.3 mm diameter tube.

Bend one end of the 0.3 mm diameter tube to 90 degrees (to insert into the hole in the float chamber).

Bend the tube again to 90 degrees such that when the end bend is inserted into the hole in the float chamber, the tube can be positioned horizontally across the rear of the engine and clear of the already added control rod tubes.

Insert the bent end into one of the pre-drilled holes in a float chamber.

Position the tube horizontally across the rear of the engine and note where to bend the straight end of the tube to route the tube forwards to the float chamber on that side of the engine.

Remove the tube and bend that end of the tube to 90 degrees.

Re-position the tube and note where to again, bend that end of the tube such that can be inserted into the hole drilled in that float chamber.

Remove the tube and bend that end of the tube to 90 degrees.

If necessary, trim that end of the bent tube so it can be fully inserted in the hole in the float chamber.

Using thin CA adhesive, secure to tube in position and into the two float chambers.

Slide the short outer tube to be centred and over the two rods from the tops of the carburettors.

Using thin CA adhesive, secure to tube in position.

Cut a long length of 0.3 mm diameter Brass tube, such as 'Albion Alloy's' (MBT03) or similar.

Bend the tube such that it can be positioned against the central, 0.5 mm diameter Brass tube and curve down and to right side of the engine, then forward between the engine round cover plate and the magneto.

Using thin CA adhesive, secure the tube in position.



Fuel drain pipes:

NOTE: *The bottom of both float chambers had drain pipes fitted, which were routed down and through the bottom engine cowl to vent fuel drains to atmosphere.*

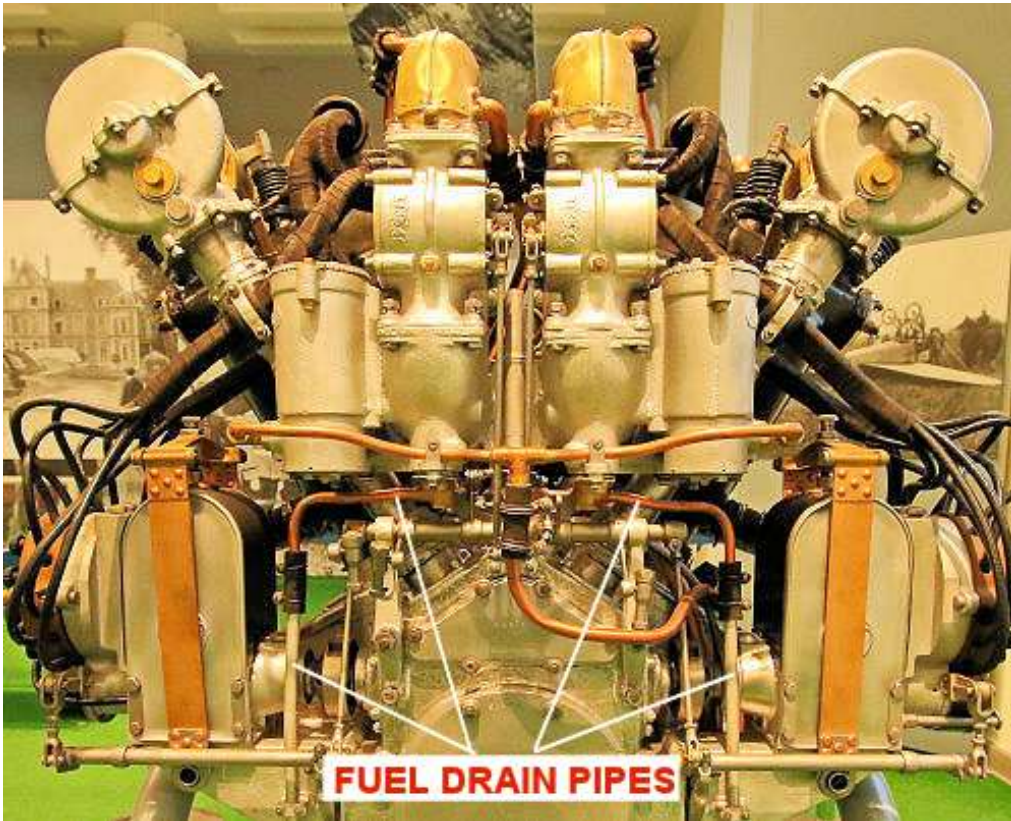

Drill a hole of 0.4 mm diameter into the bottom of the two carburetors.

Cut two lengths of 0.3 mm diameter Nickel-Silver tube, such as 'Albion Alloy's' (NST03) or similar.

Bend one end of each tube to 90 degrees.

Bend the straight ends of the tubes such that the 90 degree bent ends can be inserted into the pre-drilled holes in the carburetors with the remainder of the tubes routed down behind the control rods for the two magnetos.

Using thin CA adhesive, secure the two tubes in position.

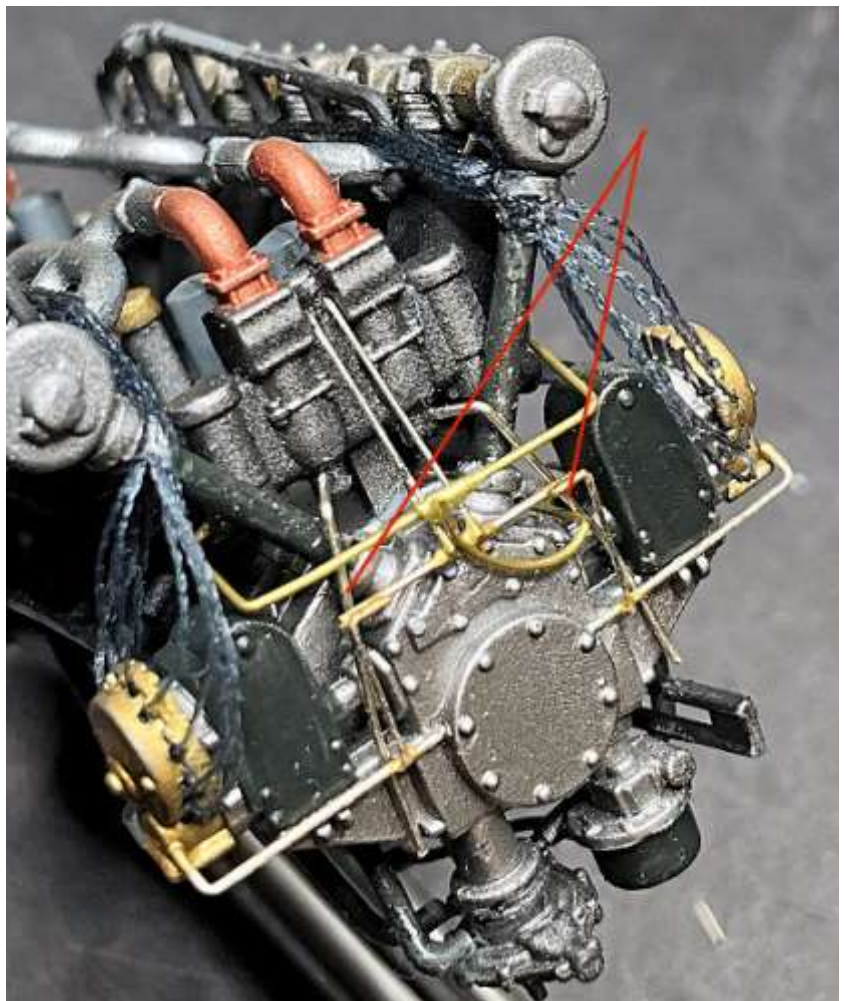

Oil pipes:

Drill a hole of 0.5 mm diameter into the front, underside of the two camshafts and into the front face of the engine crankcase.

Cut two lengths of 'MFH' 0.4 mm diameter black colour tube (P-961).

Using thin CA adhesive to secure the tubes into the pre-drilled holes in the engine crankcase.

Loop the tubes over the edge of the engine crankcase and secure in position using thin CA adhesive.

Cut the free ends of the tubes such that they can be inserted into the pre-drilled holes in the camshafts.

Using thin CA adhesive, secure the tubes into the pre-drilled holes in the camshafts.

Cut two lengths of 0.2 mm diameter Nickel-Silver tube, such as 'Albion Alloy's' (NST02) or similar, such that they will fit between to top inner edges of the carburettors and the top of the propeller reduction gear housing.

Using thin CA adhesive, secure the tubes in position to represent the control rods.

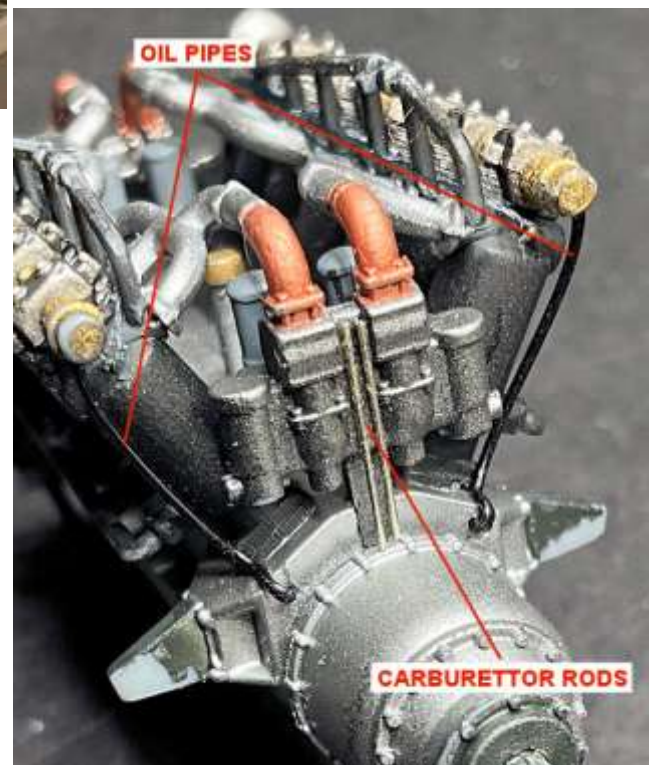

Weathering:

NOTE: A matte (flat) clear coat is better for applying heavy weathering effects.

Airbrush the engine assembly with a matte clear coat, such as 'Alclad' Flat (ALC-314) or similar.

Apply by brush small amounts of 'Abteilung 502' smoke oil paint (ABT005) or similar oil paint, along the engine sump, crankcase, propeller reduction gear housing, the engine rear housing and between the cylinder banks.

Using a suitable brush, lightly dampened with 'AMMO Mig' enamel odourless thinners (A.Mig-2019) or similar, gently brush away the oil paint in the desired directions, to achieve an oil stained look to the engine.

Apply by brush 'AK Interactive' Kerosene wash (AK2039) along the camshafts and around the two carburettor housings and pipes.

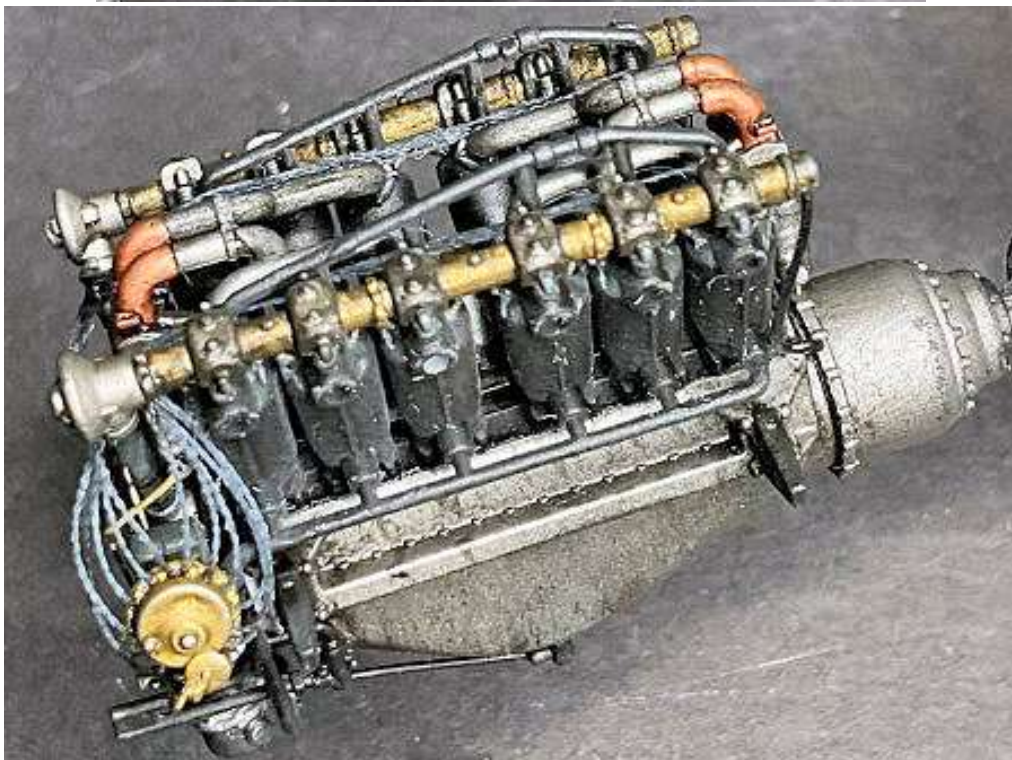

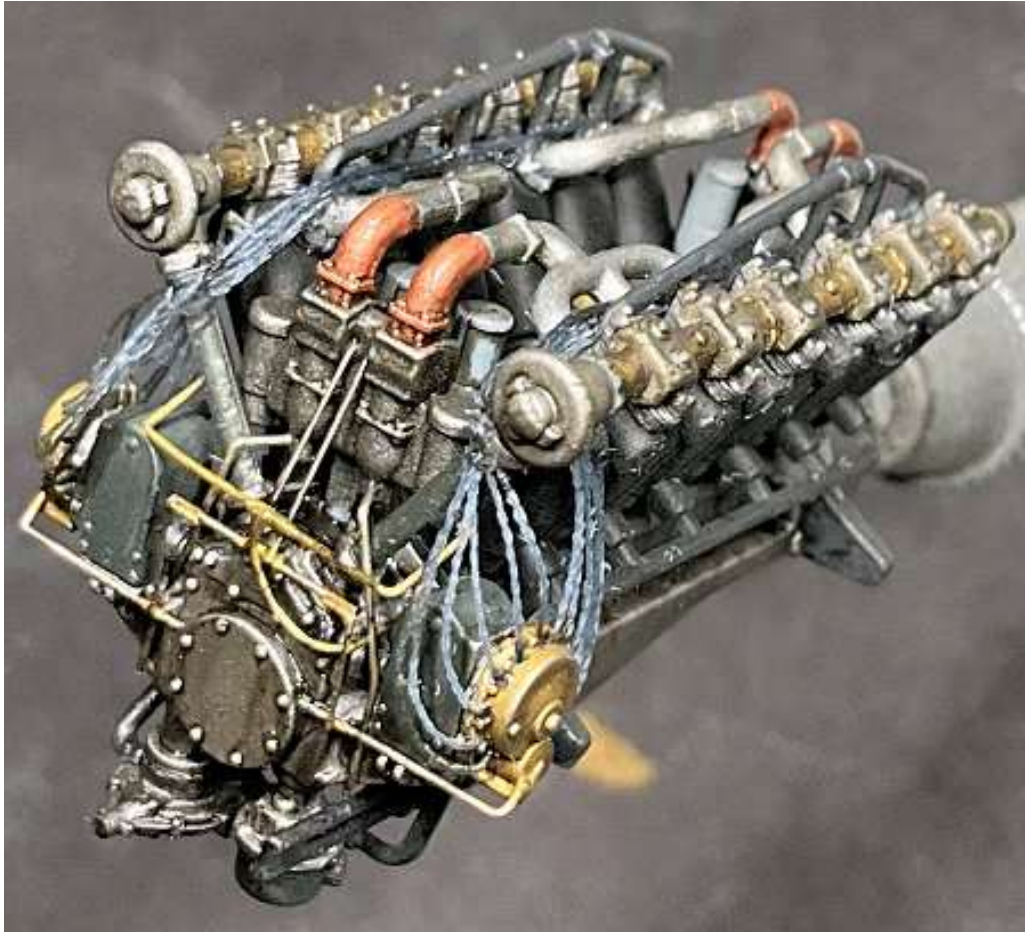

NOTE: *Other engine parts will be added after the engine has been fitted into the fuselage.*

PART 8

PROPELLER

PART 8 - PROPELLER

The kit supplied propeller will be replaced by a hand carved and laminated wood 'Bristol' propeller from Alexey Belov at 'Proper Plane'. The propeller and optional exhaust set is shown below ('Proper Plane' Bristol wood propeller and 'REXx' exhaust (PR-036-32015)).

As can just be seen in the following photographs, the propeller of this aircraft had protective covering applied to the blade tips. This would normally be doped linen, sometimes painted a light to mid grey. The coverings were intended to protect against erosion and debris damage and also as a visual indication to ground personnel that the propeller was turning.

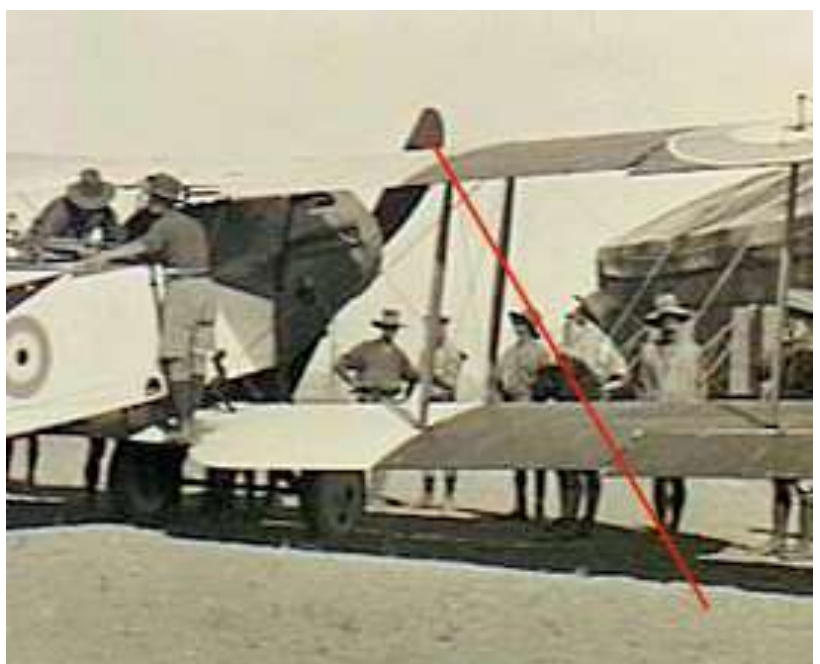
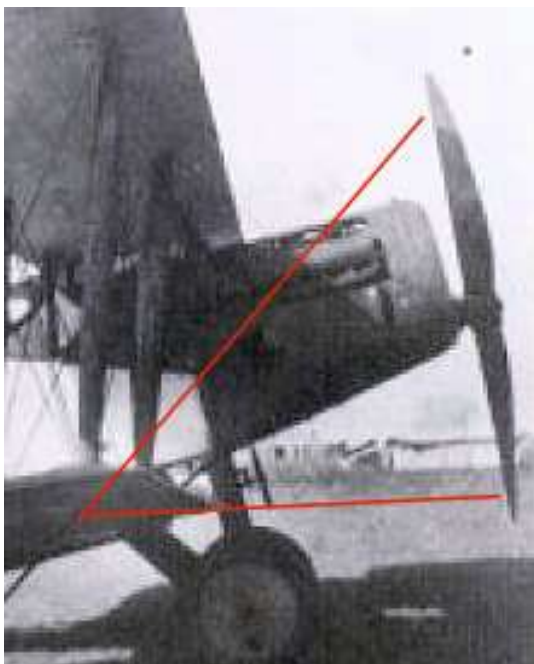

Example of tip coverings



Preparation:

Saw the two propeller hubs from their casting blocks and flat sand their rear faces to the thickness of the back plates.

Painting:

Airbrush the two propeller hub plates with 'Alclad' Steel (ALC-112) or similar.

Mask off the propeller, leaving just the blade tips exposed.

Airbrush the blade tips with 'Tamiya' Buff (XF57) or similar.

Remove the masking.

Assembly:

NOTE: Make sure you know which is the front and rear of the propeller. The previous photograph shows the **front** side of the propeller. The replacement propeller from 'Proper Plane' has the plate recess in the front of the propeller.

Using thin CA adhesive, secure the front hub into its recess on the front of the propeller hub.

Using thin CA adhesive, secure the rear hub centrally onto the rear of the propeller hub with the shaft holes aligned.

NOTE: The hole in the 'Proper Plane' replacement is larger than the diameter of the engine propeller shaft. I modified the shaft to ensure the propeller was fitted centrally on the shaft.

Drill a hole of 2.0 mm diameter through the centre of the rear propeller hub plate.

Cut a short length of 2.0 mm diameter Brass tube, such as that from 'Albion Alloy's' or similar (internal bore matches the diameter of the prop shaft. The tube length should be long enough to be able to fully insert the tube into the back plate and up to the rear of the front plate. Secure in the plates using thin CA adhesive.

Decals:

NOTE: Refer to page 21 of the kit instruction manual for decal positioning, which states that a Bristol logo decal (b) should be located on both propeller blades, which I believe is based on the Vintage Aviation Ltd aircraft. However, there seems to have been cases where only one blade had a logo, such as shown on the Bristol F.2b and Bristol Scout 1264 (see below).



Apply a kit supplied 'Bristol' decal (b) or both decals, as desired, centrally and on the front face of the propeller blade or blades.

If necessary, conform the decals to the propeller by sparingly brush applying 'Microscale' MicroSol or similar over the decals.

Painting (continued):

Airbrush a light coat of a semi-matte clear coat, such as 'Alclad' Light Sheen (ALC311) or similar, over the propeller.

Brush 'AK Interactive' Kerosene wash (AK3029) over the two propeller hubs.

Weathering:

Sponge 'Tamiya' Weather Master Sand and/or Mud (Set A) along the curved edge of the propeller blades to represent damage from sand erosion.



PART 9

FUSELAGE

PART 9 - FUSELAGE

References:

A very good reference for photographs of the Vintage Aviator Ltd Bristol F.2b can be found at the web site of James Fahey.

<https://jamesfahey.smugmug.com/Bristol-F2B/>

NOTE:

When cementing large kit parts, I use 'Revell' Contacta Professional cement (39604). This is a thicker liquid cement, which takes longer to fully set, but does provide a stronger bond between larger kit parts. 'Tamiya' liquid cement is used for smaller parts.

Before working with or cementing model parts together, make sure all mould seams, sprue tags, mould 'flash', paint or primer is removed from each part.

Refer to the relevant pages in the kit instruction manual.

My sequence of building this model may not follow the kits instruction manual. This is due to incorporating modifications as I progress through the build.

General preparation:

Some modellers work the various pieces whilst they are still attached to the main sprue, but I prefer to remove the pieces first so that I can clean them up more easily. However pieces like the cockpit frames are delicate and can easily be damaged when being removed. When parts are cut from the sprues, care should be taken as they can either break or get stressed at the cut point, which causes 'white' stress and/or deforming. For plastic kits, I use fine sprue cutters to cut away the kit part, not too close to the part, then sand off the tag. When I cut resin parts away from their mould blocks, I use a fine cutting saw, which has a more gentle cutting action. Despite being a WNW kit, there are still some fine moulding lines around items such as the cockpit frames, but they are only slight and are easily removed using a sharp blade or sanding stick. I use a new scalpel blade to gently scrape off the mould lines. Some of the model items like the parts for the cockpit are very small and can easily 'fly off' when being handled, so take care. Remember to drill any holes needed for rigging or control lines by referring to the relevant pages and diagrams in the kit instruction manual.

Primer can be applied by brush, airbrush or from aerosol cans. These days I prefer to use 'AK Interactive' Primer and Micro-filler (Grey AK758) or (White AK759). These have good coverage as the base primer for acrylics. Take care when spraying the primer as if you apply too much it will result in 'pooling' or 'runs', which would then need to be removed once the primer has dried. Make sure you spray in a well ventilated area or preferably, if you have one, use an extractor booth.

To hold items for priming I use self locking tweezers or carefully insert a toothpick into the item or I use a small piece of sticky putty, such as 'UHU White Tack', on the end of a tooth pick. Once applied the primer dries quickly, one of the main advantages of using acrylic paints rather than enamels or oil paints.

Modifications:

Despite this model being produced by Wingnut Wings, there may be a few minor changes that can be made to the model to enhance the overall effect. These will be detailed in the relevant part of this build log.

NOTE:

Refer to pages 3 to 6 and 16 of the instruction manual for parts required for the fuselage.

Preparation:

NOTE: *The internal surfaces of the fuselage halves (B3 and B4) have shallow ejector pin indents, as does the rear face of the engine bulkhead (A21) and the cockpit floor (B13). These indents will be visible so need to be removed.*

Brush 'Mr. Hobby' Mr. Surfacer 500 or 1000 or similar onto to ejector pin indents and leave to fully set.

Lightly sand over the filled ejector pin indents to blend them with the surrounding surfaces.

Make sure the following parts fit easily into their locating holes or recesses:

The top side tangs of the phot-etch rear cockpit screen (P8) into their locating recesses in the top, rear corners of the two cockpit side frames (F1 and F13).

The observers seat (A19) into its locating holes in the two cockpit side frames (F1 and F13).

The fuel tank (A32/33) into its locating holes in the cockpit floor (B13).

The forward instrument panel bulkhead (A23) into its locating hole in the two cockpit side frames (F1 and F13).

The two cockpit side frames (F1 and F13) locate fully into their locating recesses along the bottom sides of the cockpit floor (B13).

Remove the following photo-etch parts from the sheet and remove any residual tags from the edges of the parts:

Machine gun cocking lever (P9)

Seat belts (P2 x2) (P3 x2)

Cockpit rear screen (P8)

Tailplane incidence bell cranks (P5 x 4).

Assembly:

NOTE: *The pilots seat parts supplied in the kit (A20, A26 and A37) are not required as the seat will be replaced with the 3D printed 'Gaspach' British wicker seat (tall) (22-32249).*

Remove the relevant cockpit assembly parts from their sprue gates, as detailed on pages 3 to 6 of the instruction manual.

Cement the instrument panel (A42) onto its locations on the bulkhead (A23).

Cement the halves of the fuel tank (A32, A33) together.

Cement the hand pressure pump (A17) onto its locating on the top of the cockpit left side frame (F1).

Cement the two engine bearers (A2 and A12) into their locating holes on the fuselage bulkhead (A21), making sure the bearers are at 90 degrees to the front face of the bulkhead.

Cement the cross bar (A39) into its locating holes between the two engine bearers.

Cement the pipe junction (A58) into its locating hole in the bottom, front of the engine bulkhead (A21).

Cement the gun tube vent (A41) onto its locating peg on the gun tube (A49).

Cement the breech block (A27) of the machine gun into its locating holes on the gun mount (A1).

Cement the rear of the radiator (A22) into the radiator housing (A34).

Using either cement or thin CA adhesive, secure the photo-etch cocking lever (P9) onto its small locating page on the lower, right rear of the breech block (A27).

Painting:

Airbrush the following parts with a grey primer, such as 'AK Interactive' Grey (AK758) or similar and once dry, airbrush with 'Tamiya' Dark Yellow (XF60) or similar:

Cockpit side frames (F1 and F13), Cockpit floor (B13), Instrument panel (A42) (mask off the attached bulkhead), Observers seat (A19), Pilots seat and cushion ('Gaspach' replacement).

NOTE: Refer to Part 3 (Wood Effects) of this build log for more information. The method I used is Method 2, using 'Windsor & Newton' Griffin (Alkyd) Burnt Sienna and Raw Sienna oil paint.

Dark wood effect:

The following parts require a darker coloured wood effect. I used Windsor & Newton' Griffin (Alkyd) Burnt Sienna oil paint:

Cockpit left side frame (F1)
Cockpit right side frame (F13).

Light wood effect:

The following parts require a lighter coloured wood effect. I used Windsor & Newton' Griffin (Alkyd) Raw Sienna oil paint:

Cockpit floor (B13)
Instrument panel (A42)
Pilots seat ('Gaspach' replacement).

Brush a covering coat of the relevant 'Windsor & Newton' Griffin Alkyd oil paint over the part. Leave the oil paint to settle for several minutes.

Decant a small amount of White Spirits or Odourless thinners into a suitable dish.

Dip a flat oil brush into the thinners then wipe the brush on a sheet of kitchen roll (which should not deposit any fibres in the oil paint) to remove most of the thinners.

Brush the oil paint onto the part in the required direction of the wood grain and keep wiping the brush on the sheet to remove residual oil paint.

Repeat dipping and wiping the brush in the thinners and brushing the oil paint until the desired density and effect is achieved.

Leave the oil paint to fully dry. It should be touch dry in an hour or so and fully dry within 12 hours.

Leather effect:

The leather seat cushion ('Gaspach') for the pilots seat and the cushion pad on the observers seat (A19) can have a leather effect applied by using 'Windsor & Newton' Griffin (Alkyd) Vandyke Brown and Raw Sienna oil paint. First brush on the Vandyke Brown and once it begins to dry, dab on with a brush small amount of the Raw Sienna. Then using a brush dampened slightly with the thinners, lightly blend the two oil paints to create the desired leather effect. The leather effect can also be applied on the padding around the top of the pilots seat.



NOTE: *The photo-etch parts will be painted later and after they have formed into their required shapes.*

Airbrush all of the remaining styrene parts with a grey primer, such as 'AK Interactive' Grey (AK758) or similar.

Airbrush or brush paint the following parts with 'Tamiya' Neutral Grey (XF53) or similar:

- Fuel tank (A32, A33)
- Oil tank (A31)
- Control column shaft (A14)
- Instrument panel bulkhead (A23).

Airbrush or brush paint the following parts with 'Tamiya' Semi-Gloss Black (X18) or similar:

- Lewis ammunition drums (D14 x 6)
- Engine bulkhead and bearers assembly (A21, A2, A12, A39)
- Vickers gun tube (A49)
- Rudder bar (A3)
- Cross bar of control column (A14)
- Control column mounting (A50)
- Observers control column (A16)
- Hand pump (A4)
- Tailplane incidence adjuster (A13)
- Ammunition chute (A7)
- Vickers gun mount assembly (A1, A27, P9).

Airbrush the following parts with 'Alclad' Duraluminium (ALC102) or similar:

- Engine bulkhead (A21) (both sides)
- Forward upper panels of the two fuselage halves (B3, B4).

Airbrush the following parts with 'Tamiya' Deck Tan (XF55) or similar:

- Inside of the fuselage halves (B3 and B4) (not the metal painted areas).

Airbrush the body of the hand pump (A4) with 'Alclad' Pale Gold (ALC108) or similar.

Airbrush the Ammunition chute (A7), Vickers gun tube (A49) and tailplane incidence adjuster (A13) with 'Alclad' Steel (ALC112) or similar.

Airbrush the following with 'Alclad' Gun Metal (ALC120) or similar:

- Lewis ammunition drums (D14 x 6)
- Vickers gun mount assembly (A1, A27, P9).

Brush paint the hand straps on each of the Lewis ammunition drums (D16 x 6) and the circular hand grip on the control column (A14) with 'AK Interactive' Brown Leather (AK3031) or similar.

Brush paint the pipe on the cockpit left side frame (F1) with 'Mr. Colour' Copper (215) or similar.

NOTE: *The following details the brush painting the details of the previously airbrushed parts.*

Brush paint the following parts with 'Mr. Colour' Super Gold 2 (SM202) or similar:

- Body of the hand pressure pump (A17) on cockpit left side frame (F1)
- Magneto switch on cockpit left side frame (F1)
- Filler caps (x 2) on the fuel tank (A32, A33)
- Filler cap on the oil tank (A31)
- Filler cap (A18).

Brush paint the following parts with 'Tamiya' Hull Red (XF9) or similar:

- Handle of the hand pressure pump (A4)
- Handle of the hand pressure pump (A17) on cockpit left side frame (F1)
- Hand grip on Vickers gun cocking lever (P9)
- Handle of tailplane incidence control lever (A13).

Brush paint the following parts with 'Mr. Colour' Stainless Steel (213) or similar:

- Handle stem of the hand pressure pump (A4)
- Handle stem of the hand pressure pump (A17) on cockpit left side frame (F1)
- Foot restraints on rudder bar (A3)
- Top and triggers of control column (A14).

Brush paint the following parts with 'Tamiya' Rubber Black (XF85) or similar:

NOTE: Refer to Page 4 of the instruction manual.

- Base of hand pressure pump (A4)
- Rear end of Vickers gun tube (A49)
- Pilots seat support bars on fuel tank (A32, A33)
- Observers seat support struts (A19)
- Metal fittings on cockpit left side frame (F1)
- Metal fittings on cockpit right side frame (F13)
- Instrument bezels on instrument panel (A42)
- Observers control column mounting on cockpit floor (B13).

NOTE: Dry brush by using a domed and soft brush, which has a very light dusting of paint. Dry off paint on the brush on an absorbent paper before dry brushing the part.

Dry brush the following parts with 'Mr. Colour' Super Iron 2 (SM203) or similar:

- Instrument panel bulkhead (A23) (not the attached instrument panel)
- Lewis ammunition drums (D14 x 6)
- Vickers gun mount assembly (A1, A27, P9).
- Fuel tank (A32, A33)
- Oil tank (A31).

Decals:

NOTE: The Clear Doped Linen decals used are the 'Aviatic' Bleached CDL (clear backed) (ATT32044) decal. The 'Aviatic' linen decals are unlike normal screen printed decals, in that when being applied, have the ability to be handled with slightly less care than normal and they have the ability to stretch slightly, which standard decals do not. That said, if you handle them too roughly, damage can occur.

Make sure the model surface for each decal to be applied is clean and smooth or particles on the surface may cause 'silvering' (trapped air) under the decals when dry.

The 'Aviatic' CDL decals being used are not 'cookie' cut to the shapes required. Therefore the decals must be **hand cut** to shape. The following procedure applies to **both** fuselage halves.

Cut a paper or tracing paper template to fit on the inside side wall of a fuselage half, except for the metal painted area. The template does not need to fit all of the way to the rear of the fuselage.

Place the template onto the back of the decal sheet such that when cut, the decal will be the correct shape for applying to the fuselage half.

Using a pencil, lightly trace the outline of the template onto the rear of the decal sheet.

Cut out the decal and check that it will fit correctly onto the fuselage side wall.

NOTE: *To aid in adhesion, you can mix a small amount of PVA (white glue) into the decal water.*

Wet the model surface with clean water.

Soak the decal in the warm decal water for approximately 30 seconds or long enough to be able to move the decal on its backing sheet.

Carefully lift the decal on its backing sheet from the water. Make sure the decal does not fold over on itself, as it will be difficult to separate a fold once out of the water.

Carefully slide the decal off one end of the backing paper and position the decal end onto the fuselage side wall and holding that end, slide out the backing paper.

Using large, flat brush or cotton buds, start to smooth out the decal at one end, removing any water from underneath and smoothing the decal onto the surface. Continue this along the length of the decal, taking care not to grip the decal surfaces with your fingers, as this will cause ripples in the decal.

Once the decal is smoothed down onto the model surface, apply pressure along the decal with soft and dry tissue paper or by finger pressure whilst wearing lint free cotton gloves. This will expel any remaining water and press the decal on to the model surface. Check over the decal to make sure there are no tears or folds, which need to be rectified before the decal sets.

NOTE: *If the decal covers locating holes, slots or other openings, prick through the decal over holes or slice the decal over openings, then brush either 'MicroScale' MicroSol' or sparingly 'Tamiya' X20A thinners into the holes or around the openings. This will soften and conform the decal. If the decal needs to be conformed around curved edges etc, brush sparingly 'Tamiya' X20A thinners across the decal edge. This will soften and conform the decal. Once fully dry and set, trim any excess decal from edges using a sharp blade, such as a shielded razor blade.*

Repeat the procedure to apply CDL decal to the bottom of the fuselage half.

Repeat the procedure to apply CDL decal to the side wall and bottom of the opposite fuselage half.

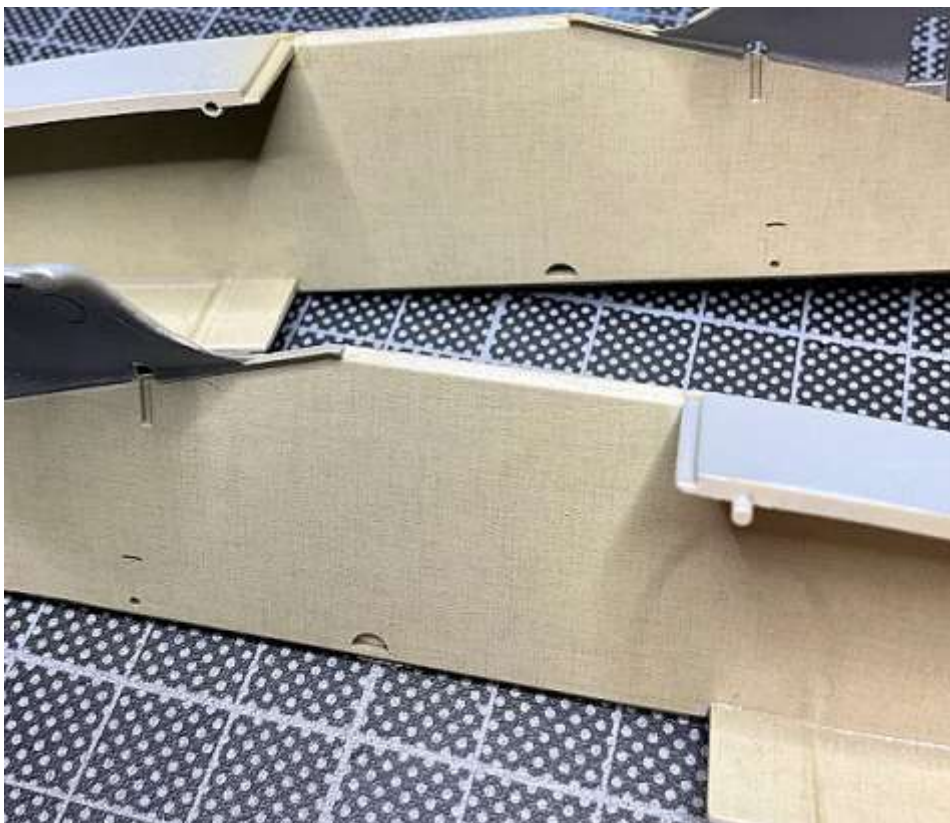

Kit supplied decals:

Airbrush a gloss clear coat, such as 'Alclad' Aqua Gloss 600 or 'Ammo' Aqua Gloss Clear (A.MIG -2503) or similar, over the instrument panel (A42).

NOTE: *The kit supplied decals required for the instrument panel are decals 45 to 51. Refer to Page 4 of the kit instruction manual for positioning of the required decals.*

Apply decal 45 to 51 in their required locations on the instrument panel.



Assembly (continued):

NOTE: *Before any assembly of parts, make sure all primer and paints are removed from any locating holes, recesses and mating surfaces. This will ensure parts will fully locate together.*

Cement the Lewis ammunition drums (D14 x 6) onto their locating pegs on the cockpit side frames (F1, F13).

Cement the fuel tank (A32, A33) into its locating holes in the cockpit floor (B13).

Cement the observers control column (A16) into its locating holes in the cockpit floor (B13).

Cement the tailplane incidence adjuster (A13) onto its location on the right end of the fuel tank.

Using CA adhesive, secure the pilots seat cushion onto the seat ('Gaspatch replacement').

Using CA adhesive, secure the pilots seat ('Gaspatch replacement') onto the fuel tank assembly.

Cement the control column (A14) into its locating holes in the cockpit floor (B13).

Cement the rudder bar mount (A50) into its locating holes in the cockpit floor (B13).

Cement the rudder bar (A3) into its locating hole in the mount (A50), making sure it's parallel with the cockpit floor when viewed from the front and at 90 degrees across the floor when viewed from above.

Cement the hand pressure pump (A4) into its locating holes in the cockpit floor (B13).

Cement the cockpit right side frame onto its locating recess along the right, bottom side of the cockpit floor and onto the locating pegs on the end of the support bars for the pilots seat (on the fuel tank).

Cement the cockpit left side frame onto its locating recess along the left, bottom side of the cockpit floor and onto the locating pegs on the end of the support bars for the pilots seat (on the fuel tank).

Gently ease the rear ends of the cockpit side frames apart and locate and cement the observers seat into its locating holes in the side frames.

Gently ease the front ends of the cockpit side frames apart and locate and cement the instrument panel/bulkhead assembly into and against its locating holes in the side frames.

Cement the Vickers gun mount assembly (A1, A27, P9) into its location in the top, rear of the instrument panel bulkhead.

Temporarily hold the two fuselage halves together with elastic bands.

Locate the cockpit assembly into the fuselage from below, making sure it fully locates. The front bulkhead should fit into the pre-moulded shoulders inside the fuselage. If necessary, mating surfaces should be sanded, scraped or filed to achieve a full fit of the cockpit assembly into the fuselage.

Test fit the engine bulkhead/bearers assembly into the fuselage. The flat sided ends of the engine bearers should be against the locating flats on the inner, fronts of the cockpit side frames, with the engine bulkhead fully against the front edges of the cockpit sides frames and floor. The engine and radiator can also be test fitted.

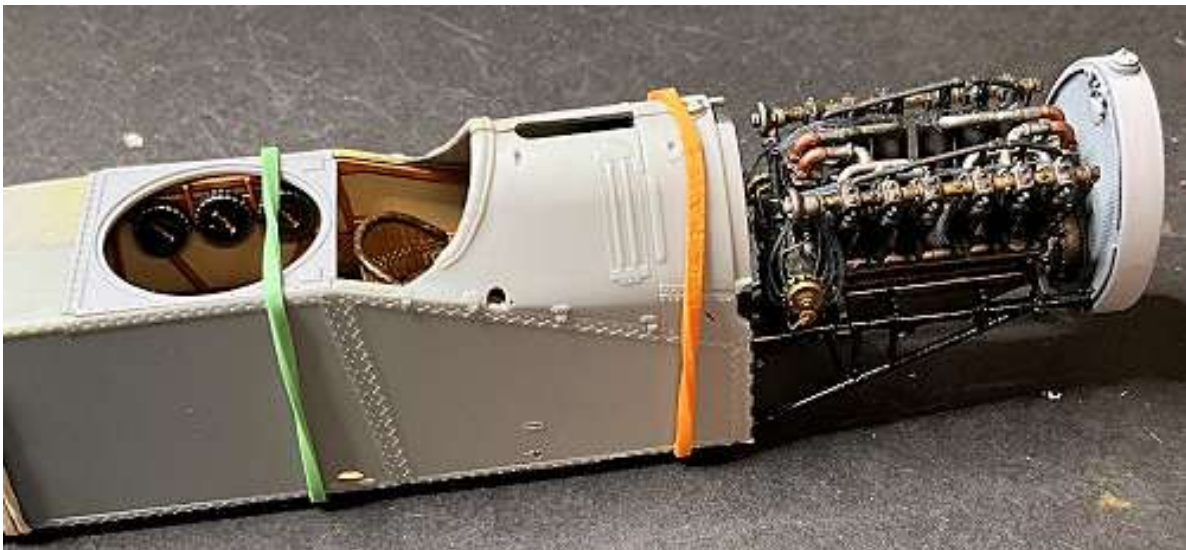

If fitted, remove the radiator and engine.

Remove the cockpit assembly with the engine bulkhead/bearers in position.

Cement the ends of the engine bearers and the bulkhead to the cockpit side frames.

Photo-etch parts:

NOTE: *The photo-etch parts required for the cockpit are:*

Pilots seat belts (P2, P3)

Observers seat belts (P1)

Observers cockpit cloth screen (P8).

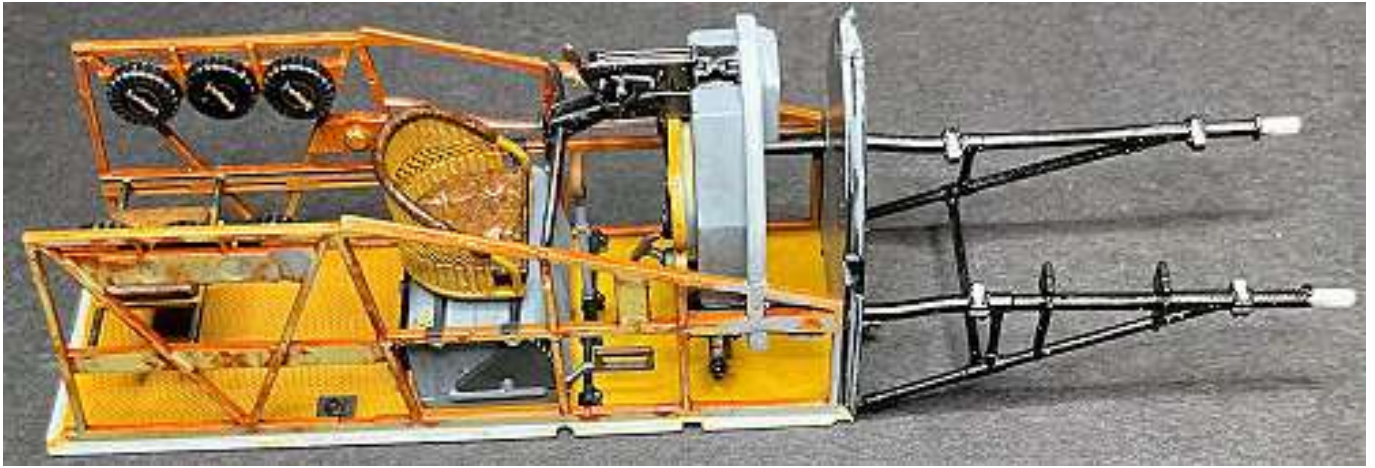

Cloth screen (P8) forming:

Using a naked flame, such as that from a cigarette lighter, heat the bottom area of the photo-etch cloth screen until it changes colour. This will anneal (soften) the photo-etch to enable it to be bent to shape more easily.

Lightly sand the screen edges that will be joined together (refer to Page 5 of the instruction manual).

Pinch the sides and fold the bottom of the screen up such that the side edges align to each other.

Secure the two bottom sides together using thin CA adhesive. As an alternative, I used solder paste and applied heat to join the photo-etch.

Use a suitable round former to shape the two pockets in the bottom of the cloth.

If necessary, secure the centre of the folded cloth in position using thin CA adhesive.

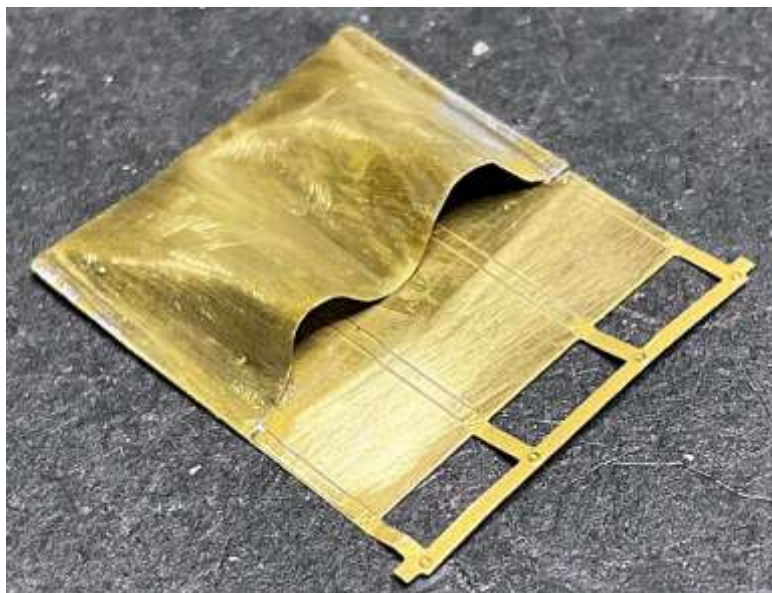

Cloth screen (P8) painting:

Airbrush the screen with a grey primer, such as 'AK Interactive' Grey (AK758) or similar.

Airbrush the back sheet with an off-white, such as 'Hataka' Insignia White (C049) or similar.

Brush paint the folded front sheet with 'Tamiya' Buff (XF57) or similar.

Brush paint the wood supports with 'Tamiya' NATO Brown (XF68) or similar.

Brush paint the metal retainers on the wood supports with 'Mr. Colour' Stainless Steel (213) or similar.

Seat belts (P2, P3) preparation:

Using a naked flame, such as that from a cigarette lighter, heat the four seat belts (P2,P3) until they change colour. This will anneal (soften) the photo-etch to enable it to be bent to shape more easily.

Seat belts (P2, P3) painting:

Airbrush the seat belts with a grey primer, such as 'AK Interactive' Grey (AK758) or similar.

Airbrush the seat belts with 'Tamiya' Buff (XF57) or similar.

Brush paint the perforated area of the main belt with 'AK Interactive' Leather (AK3031) or similar.

Brush paint the metal fittings of the belts with 'Mr. Colour' Stainless Steel (213) or similar.

Assembly (continued):

NOTE: Before any assembly of parts, make sure all primer and paints are removed from any locating holes, recesses and mating surfaces. This will ensure parts will fully locate together.

Seat belts (P2, P3) fitting:

NOTE: It's unclear as to exactly where the seat belts were attached to the fuselage. Therefore, I chose to attach them to the cockpit side frames.

Drill a hole of 0.6 mm diameter through the sides of both cockpit side frames, as shown in the following photograph.



NOTE: The seat belts are fitted as shown on the 'HGW Models' illustration for their seat belt set.

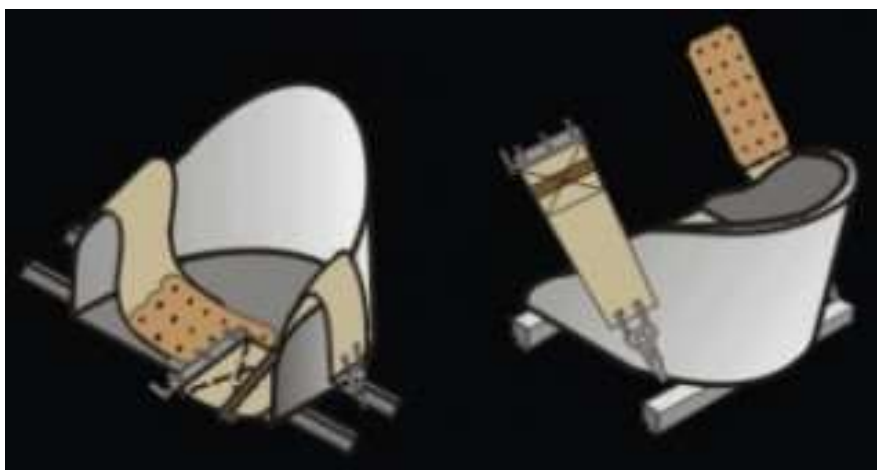

Slightly bend the tang on the end fittings of one pair of seat belts.

Insert (from the inside of the cockpit side frames) the bent tangs of the seat belts into the pre-drilled holes in the cockpit side frames at the pilots seat.

Angle the belts slightly forward and secure into the cockpit side frames using thin CA adhesive.

Using cotton buds or similar, carefully bend the seat belts over the pilots seat and onto the seat cushion.

Secure the belts to the pilots seat using thin CA adhesive.

Using the same procedure, attach the remaining two seat belts to the rear of the cockpit side frames and onto the observers seat.

Cloth screen (P8) fitting:

NOTE: *The top, outer tangs of the photo-etch cloth screen are intended to be located into the small pre-moulded slots in the top, rear corners of the cockpit side frames. However, these locations are weak and the top 'support' across the cloth screen will be easily distorted during insertion of the cockpit assembly into the fuselage. Therefore, I chose not to use the locations.*

Apply CA adhesive to the rear of the back seat support bar on the observers seat.

Locate the folds of the cloth screen against the adhesive with its bottom edge aligned to the knurled surface on the rear of the cockpit floor.

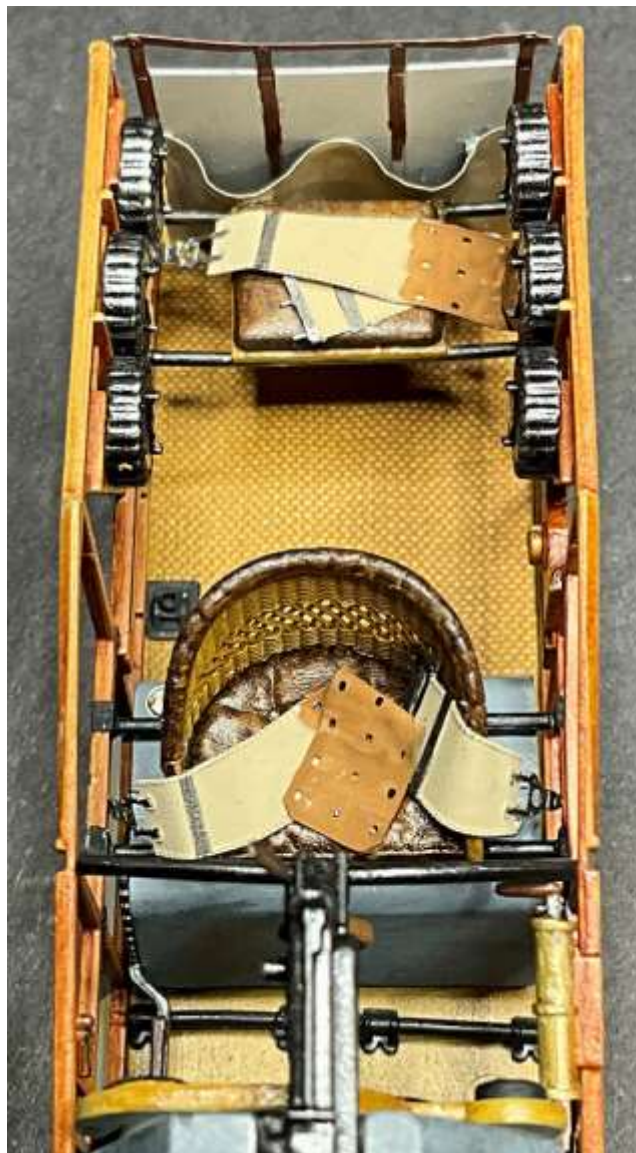

Weathering:

NOTE: Refer to Part 4 (Weathering) of this build log for more information.

Lightly airbrush a semi-matte clear coat, such as 'Alclad' Light Sheen (ALC-311) or similar, over the cockpit assembly, inner sides of the fuselage and the engine bulkhead/bearers. This will provide a good base for applying weathering.

Apply weathering, as desired, to the cockpit assembly. I used 'Flory Models' Grime fine clay wash on the cockpit wood surfaces and Dark Dirt on the bulkheads.

Once the desired effect is achieved, lightly airbrush coat of a semi-matte clear coat, such as 'Alclad' Light Sheen (ALC-311) or similar, over the cockpit assembly, inner sides of the fuselage and the engine bulkhead/bearers. This will seal the applied weathering.

Painting (continued):

Brush a gloss clear coat, such as 'Tamiya' Clear Gloss (X22) or similar, onto the faces of the instruments on the pilots panel.

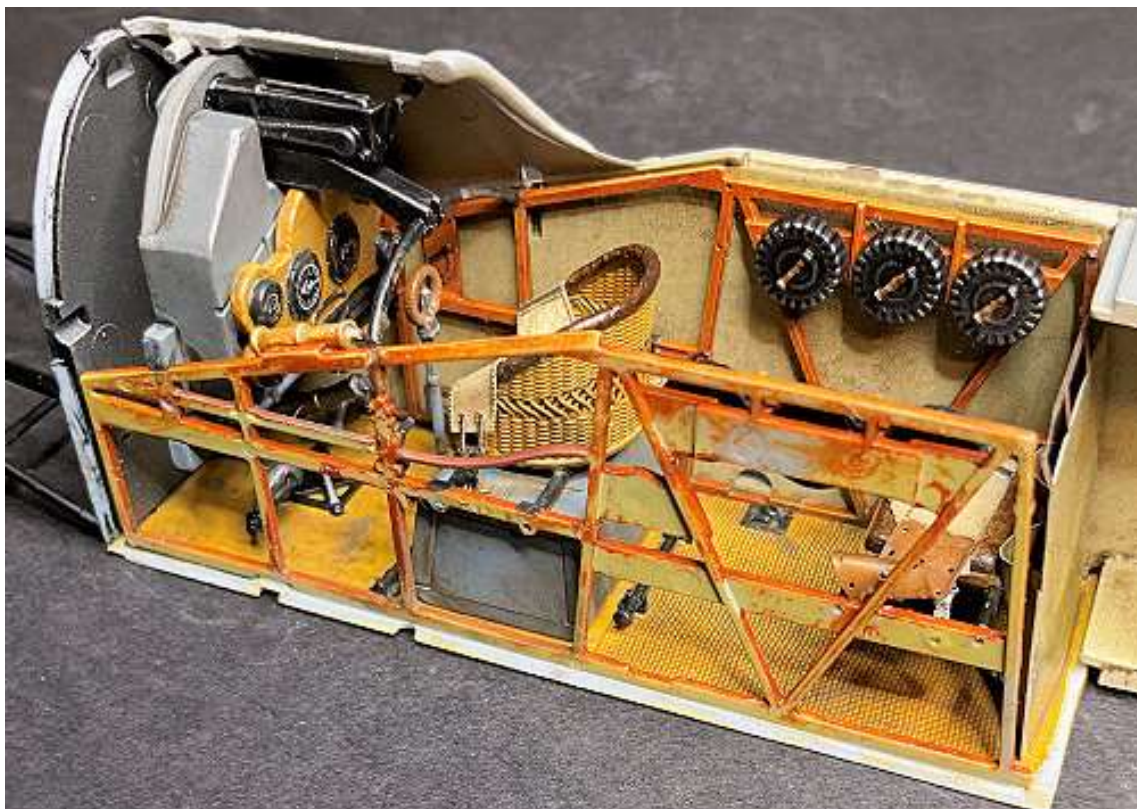

Modifications:

Pilots controls:

NOTE: *The cockpit had the pilots throttle control quadrant located on the cockpit left side frame.*



Cut four lengths of 0.3 mm diameter Nickel-Silver tube, such as 'Albion Alloy's' NST03 or similar.

Trim the length of two tubes such that they can be positioned with one end in the recess at the bottom of the instrument panel bulkhead and the opposite ends midway along the two throttle quadrant levers.

Secure the two tubes in position using thin CA adhesive.

Trigger cable:

NOTE: *The pilots Vickers machine gun was operated by a cable attached from the trigger tab on the control column. The cable was routed down the control column and presumably forwards and up, to be connected to the firing mechanism of the machine gun.*



Cut a blackened length of 0.3 mm diameter Nickel-Silver tube, such as 'Albion Alloy's' NST03 or similar.

Trim the length of the tube such that it can be positioned with one end on the cockpit floor at the rear of the control column and the opposite end at the trigger pad at the top of the control column.

Secure the tube in position using thin CA adhesive.

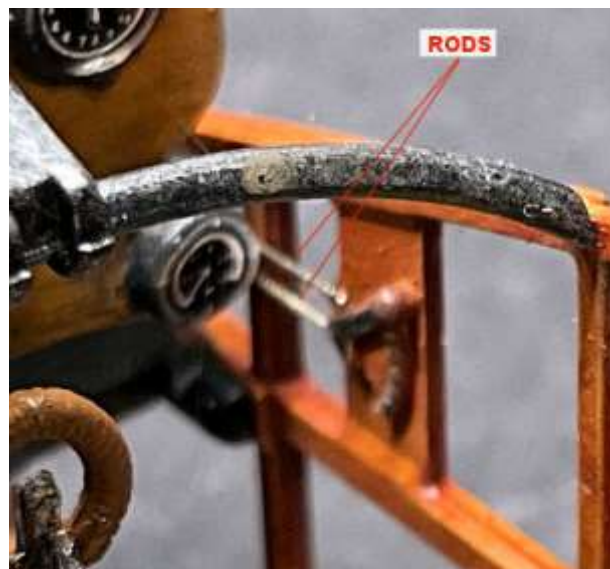

Engine access panels:

NOTE: Photographs of this particular aircraft show what seems to be an 'in-field' medication to the two upper access panels. (B9, B10). The blister on each panel was needed to clear the panel from the engine upper coolant pipes. These blisters were cut away in order to provide an opening for additional engine cooling, as the aircraft operated in the warmer climate of Palestine.

Also the upper access panels will be displayed off the aircraft.

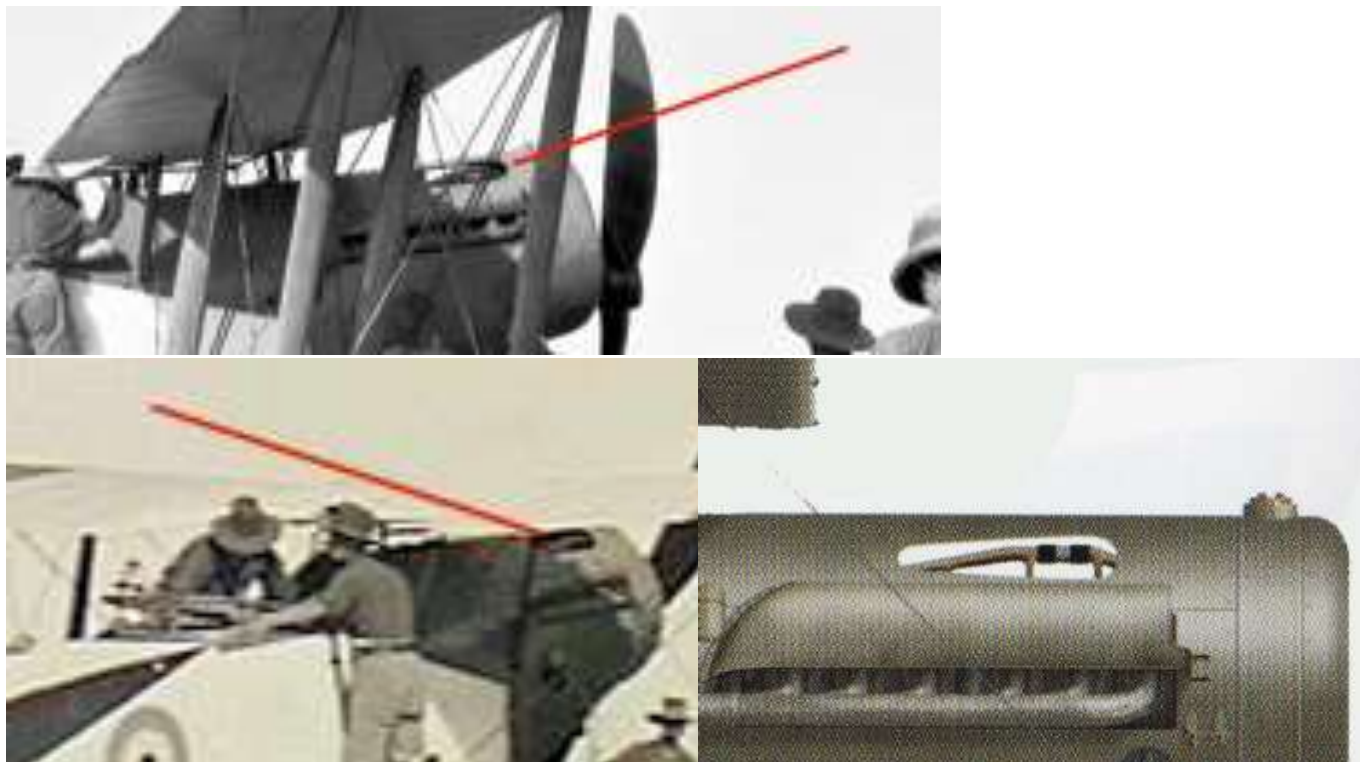

NOTE: *The following procedure applies to both engine upper access panels (B9, B10).*

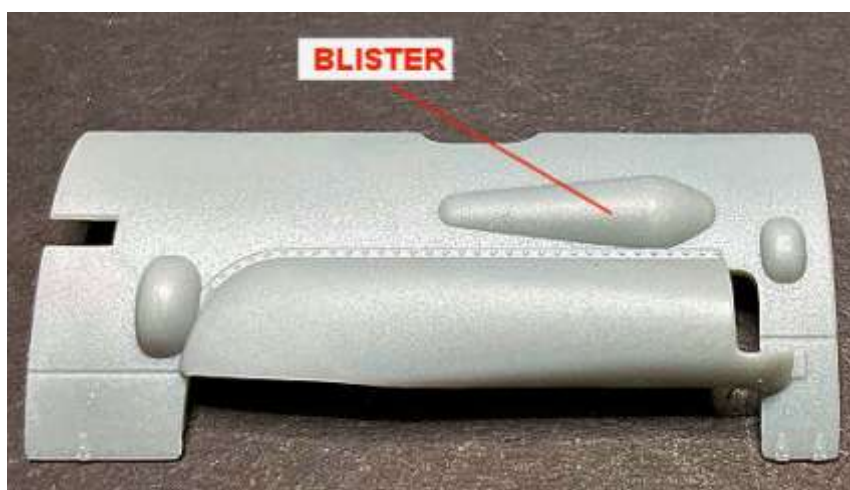

Using a suitable diameter drill, chain drill around the blister inside its outer edges.

Cut through the holes to remove the remains of the blister.

File/scrape the edges of the opening to create a smooth edged opening of the original blister.

File/scrape the inside edges of the opening to reduce its thickness to a more realistic scale.

Cement the upper edges of the two panels together, keeping the edges aligned.

Using 'Deluxe Materials' Perfect Plastic Putty or similar, fill the joint between the two panels and the recess at the top of the engine bulkhead.

Once fully set, sand the filler to blend it with the surrounding panel surfaces.



Panel air scoops:

NOTE: *The engine access panel (B12) and two side panels (B7, B8) have pre-moulded air scoops. However, the thickness of these scoops is not to scale, so the scoops need to be thinned.*

Using a sharp, straight edge scalpel blade, carefully cut or scrape away the inside of the three air scoops to achieve a more realistic thickness.

Any minor surface imperfections can be smoothed out by applying liquid cement over the worked areas of the panels.

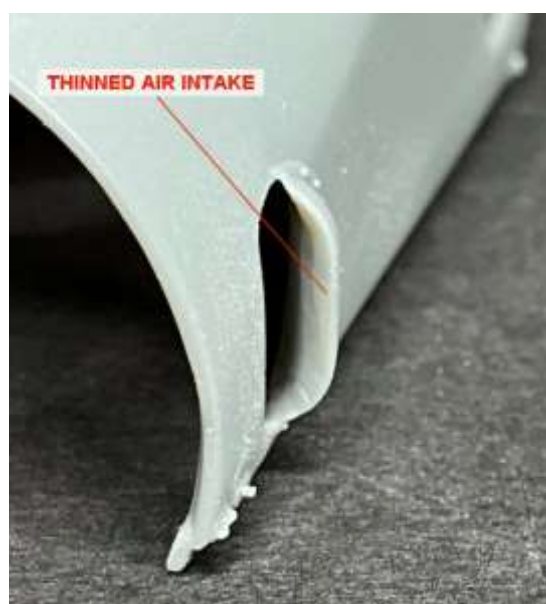
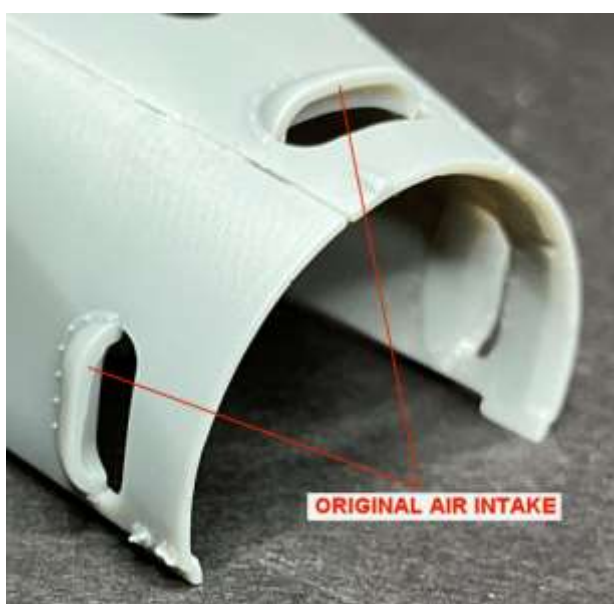

Cockpit rigging:

NOTE: *Refer to Part 6 (Rigging General) of this build log for more rigging information. The control cables were rigged using 'YLI' silk thread #100.*

Rudder control cables:

Cut two long lengths of 'YLI' silk thread #100.

Loop each thread around the outer ends of the rudder bar.

Pass the threads rearwards inside the cockpit side frames and pass them through to the rear face of the fitted photo-etch cloth screen at the rear of the observers cockpit.

Gently tension each line, keeping them parallel and secure them to the rear face of the cloth screen using thin CA adhesive.

Cut away any residual end tags of the threads.

Aileron control cables:

Cut a long length of 'YLI' silk thread #100.

Pass the thread across the pilots cockpit in front of the control column.

Secure the centre of the thread to the top of the base fitting of the control column, using thin CA adhesive.

Pass the ends of the thread out and over the bottom edges of the cockpit side frames and keeping the tensioned, secure them to the bottom edges of the side frames, using thin CA adhesive.

Cut away any residual end tags of the threads.

Tailplane incidence control cables:

Cut two long lengths of 'YLI' silk thread #100.

Keeping the two threads apart and parallel, secure one end of the two threads onto the right side of the fuel tank and against the rear edge of the tailplane incidence control lever.

Pass the threads rearwards inside the cockpit right side frames and pass them through to the rear face of the fitted photo-etch cloth screen at the rear of the observers cockpit.

Gently tension each line, keeping them parallel and secure them to the rear face of the cloth screen using thin CA adhesive.

Cut away any residual end tags of the threads.

Cockpit assembly test fitted only.

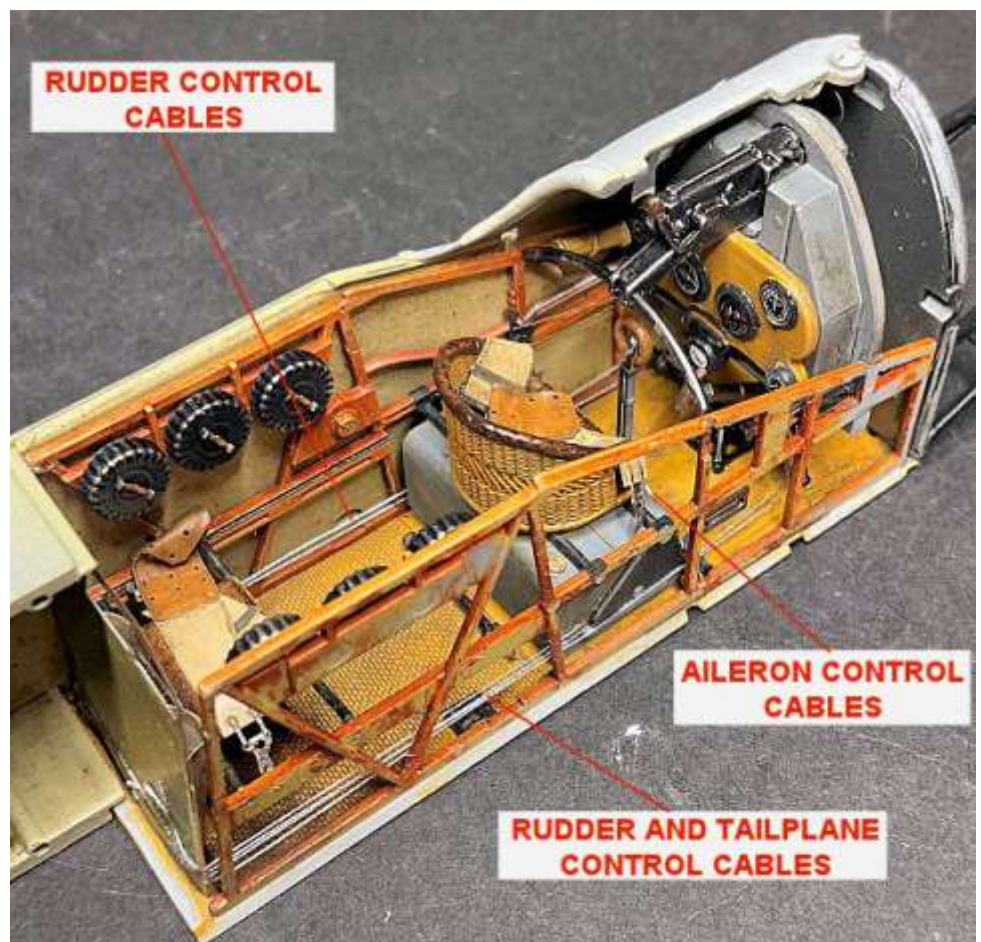

Cockpit assembly test fitted only.

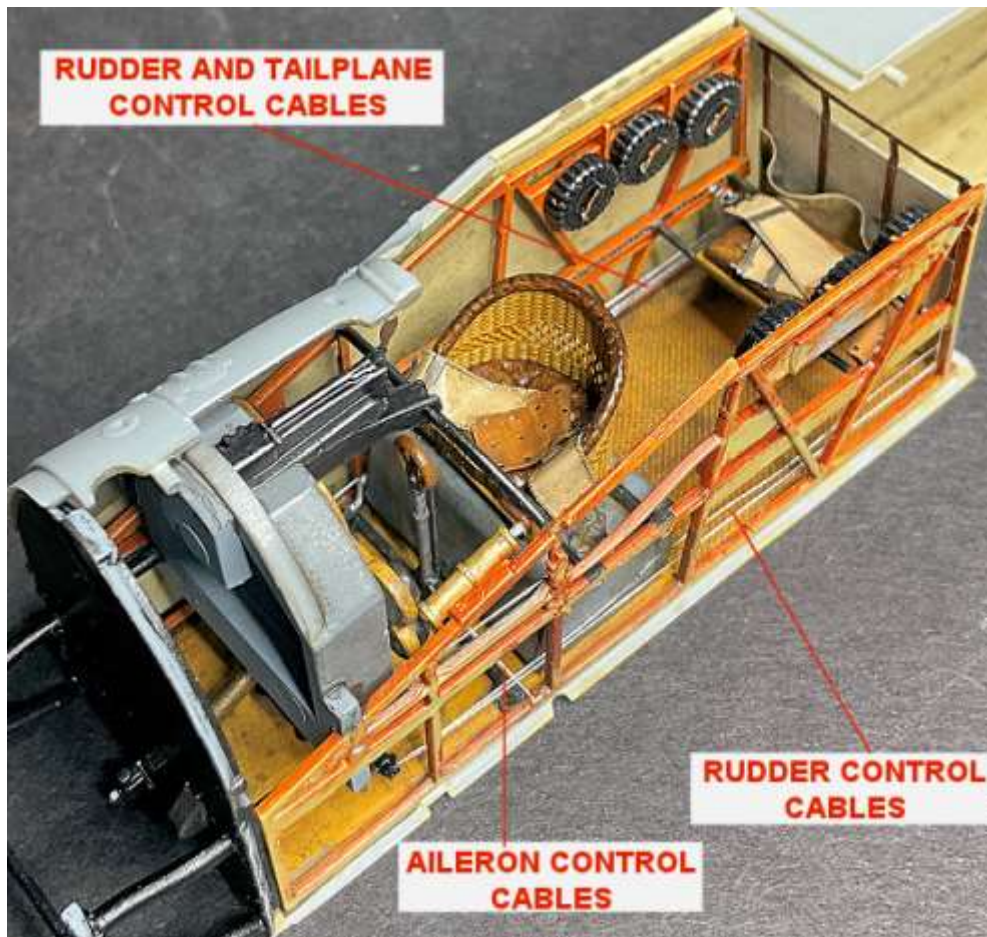

Assembly (continued):

Hold the two fuselage halves together and test fit the cockpit assembly into the fuselage by inserting it from the opening in the underside of the fuselage. Make sure the cockpit assembly fully locates into the fuselage without any restriction and with no obvious gaps at the edges.

Cement the two fuselage halves together.

Insert the cockpit assembly into the fuselage and cement in position.



Bracing wires:

NOTE: *The cockpit side frames could be liable to flex slightly when the cockpit assembly is fitted into the fuselage. This could distort or break away any fitted bracing wires, especially those crossed wires fitted across the cockpit. Therefore, although a more difficult procedure, I chose to fit the cockpit bracing wires after the cockpit assembly was fitted into the fuselage.*

If in doubt, *I would suggest that the bracing wires are fitted to the cockpit assembly before it is fitted into the fuselage and to use a stretch line, such as 'EZ' line, which although not really of the correct colour, will flex with the cockpit.*

Refer to Part 6 (Rigging General) of this build log for more rigging information for the cockpit bracing wires.

To add the cockpit bracing wires, I used 'Albion Alloy's' 0.2 mm diameter Nickel-Silver rod. The rod was cut into the lengths required to be able to span between the various bays of the cockpit side frames. These rods were then secured in their locations using CA adhesive at their ends and also where the rods crossed. The cross bracing wires behind the pilots seat were secured in position by being located into the pre-moulded holes in the cockpit floor and cockpit side frames. The cross bracing wires across the cloth screen at the rear of the observers cockpit were secured in position by being located between the cockpit side frames.



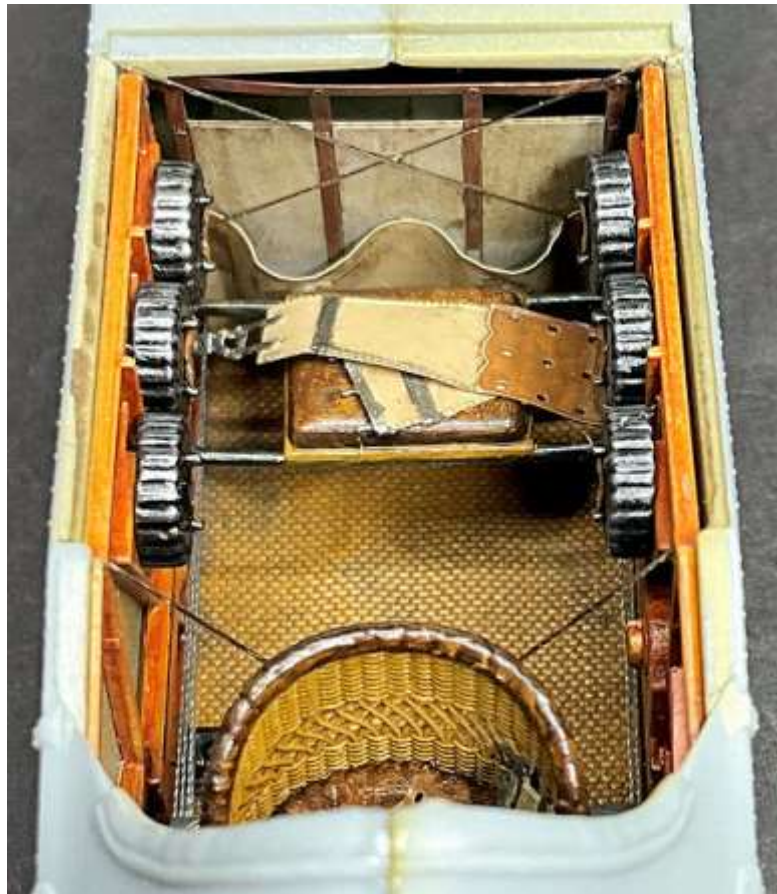
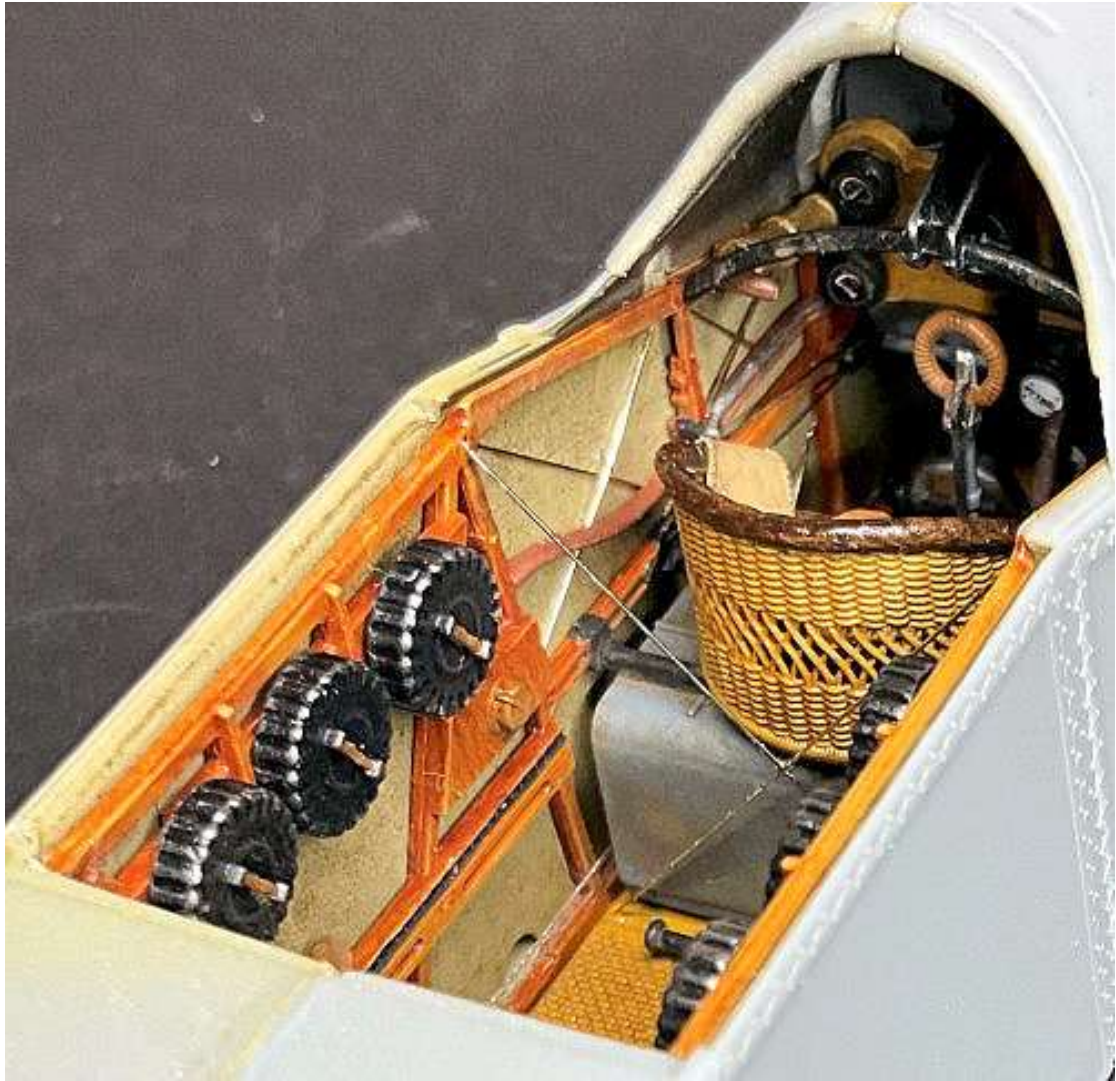

Check all of the fuselage joints and seams. Where necessary, fill any depressions in seam joints using such as 'Mr. Hobby' Mr. Surfacer 500, 1000 or 1200. Sand the seam joints to blend them with the surrounding surfaces.

Cement the observers cockpit surround (A25) into its location in the fuselage.

Test fit the engine underside access panel (B12) and two side panels (B7, B8) together and in position around the engine bearers. Make sure the panels locate fully together and against the fuselage edges.

Cement the access panel (B12) and two side panels (B7, B8) together.

Cement the engine oil tank (A31) onto its locations on the right engine bearer (A12).

Together, test fit all of the following :

Access panel assembly (B12, B7 and B8)

Engine assembly in the engine bearers

Radiator onto the front of the engine bearers.

Make sure all assemblies and parts fully locate to each other with no obvious gaps between the parts. If necessary, remove styrene from the un-painted surfaces to achieve the required fit.

Remove the test fitted assemblies and parts from the fuselage.

Painting (continued):

Airbrush the joined and modified upper engine access panels with a grey primer, such as 'AK Interactive' Grey (AK758) or similar.

Airbrush the joined lower engine access panels with a grey primer, such as 'AK Interactive' Grey (AK758) or similar.

Airbrush the inside of the engine panels with 'Alclad' Duraluminium (ALC102) or similar.

NOTE: Refer to Part 4 (Weathering) of this build log for more information.

Lightly airbrush a semi-matte clear coat, such as 'Alclad' Light Sheen (ALC-311) or similar, over the inside of the panels. This will provide a good base for applying weathering.

Apply weathering, as desired, to the inside of the panels. I used 'Flory Models' Grime fine clay wash on the cockpit wood surfaces and Dark Dirt on the bulkheads.

Once the desired effect is achieved, lightly airbrush coat of a semi-matte clear coat, such as 'Alclad' Light Sheen (ALC-311) or similar, over the inside of the panels. This will seal the applied weathering.

Mask off the outer edge of the radiator assembly then airbrush the front and rear faces of the radiator with 'Alclad' Steel (ALC-112) or similar.

Brush 'AK Interactive' Kerosene (AK2039) over the front and rear matrix of the radiator.

Airbrush the radiator shutters with 'Tamiya' Neutral Grey (XF53) or similar.

Mask off all fuselage openings, holes and the engine bearers/bulkhead. I use a combination of the pointed ends of wood toothpicks, 'UHU' white tack rolled into 'worms' for around edges and kitchen 'Clingfilm' food wrap to fill large openings.

Mask off the inside surfaces of the engine lower access panels assembly.

Mask off the inside surfaces of the engine upper access panels assembly.

Mask off the front and rear faces of the radiator.

Stick the engine oval front cowl onto a strip of masking tape.

Airbrush a white primer, such as 'AK Interactive' White (AK759) or similar over the fuselage.

Very lightly sand the painted surfaces on the fuselage expose the grey styrene underneath. The intention is to create a worn and dirty effect. Sand across the top, underside and sides of the fuselage.

Very lightly airbrush 'Tamiya' Smoke (X19) or similar along the edges of the various stitching runs on the fuselage.

Make sure the painted surfaces are smooth and clear of any surface imperfections. If necessary, lightly sand the surfaces to a smooth finish.

NOTE: *Applying a clear gloss coat is to provide a better surface for applying decals.*

Airbrush the fuselage (not the areas detailed in red in the following illustration) with a gloss clear coat, such as 'Alclad' Aqua Gloss 600 or 'Ammo' Aqua Gloss Clear (A.MIG-2503).



Decals:

Example of applying 'Aviatic' decals:

NOTES: *The Clear Doped Linen decals used are the 'Aviatic' (clear backed) decal. The 'Aviatic' linen decals are unlike normal screen printed decals, in that when being applied, have the ability to be handled with slightly less care than normal and they have the ability to stretch slightly, which standard decals do not. That said, if you handle them too roughly, damage can occur.*

Make sure the model surface for each decal to be applied is clean and smooth or particles on the surface may cause 'silvering' (trapped air) under the decals when dry.

The 'Aviatic' decals being used are not 'cookie' cut to the shapes required. Therefore the decals must be hand cut to shape.

Lay the part (with surface to have decal) down onto the rear (blank) side of the decal sheet.

NOTE: *During the following step, do not press too hard when tracing the outline as this may mark the decal side of the sheet.*

Using a pencil, lightly trace the outline of the part onto the rear of the decal, allowing for any curvature of the part, such as wings.

Carefully cut out the decal shape.

NOTE: For the fuselage, lay paper onto the side of the fuselage then rub the side of the pencil lead along the edges/stitching. This will create the outline of the stitching, allowing the decal to be cut out accurately.

Check that the decal fits correctly over the surface of the part.

NOTE: To aid in adhesion, you can mix a small amount of PVA (white glue) into the decal water.

Wet the model surface with clean water.

Soak the decal in the warm decal water only until the decal can be moved on its backing sheet.

Carefully lift the decal on its backing sheet from the water. Make sure the decal does not fold over on itself, as it will be difficult to separate a fold once out of the water.

Carefully slide the decal off one end of the backing paper and position the decal end onto the wing and holding that end, slide out the backing paper.

Using large, flat brush or cotton buds, start to smooth out the decal at one end, removing any water from underneath and smoothing the decal onto the surface. Continue this along the length of the decal, taking care not to grip the decal surfaces with your fingers, as this will cause ripples in the decal.

Once the decal is smoothed down onto the model surface, apply pressure along the decal with soft and dry tissue paper or by finger pressure whilst wearing lint free cotton gloves. This will expel any remaining water and press the decal on to the model surface. Check over the decal to make sure there are no tears or folds, which need to be rectified before the decal sets.

NOTES:

*If the decal covers locating holes, slots or other openings, prick through the decal over holes or slice the decal over openings, then brush either 'MicroScale' MicroSol' or **very sparingly** 'Tamiya' X20A thinners, into the holes or around the openings. This will soften and conform the decal. Too much X20A will **melt** the decal.*

*If the decal needs to be conformed around curved edges etc, brush **very sparingly** 'Tamiya' X20A thinners across the decal edge. This will soften and conform the decal.*

Once fully dry and set, trim any excess decal from edges using a sharp blade, such as a shielded razor blade.

Application:

NOTES: The decals used to cover the fuselage are the 'Aviatic' Off White Linen (ATT32241), Clear Doped Linen (CDL) (ATT32044) and PC10 Medium (ATT32090).

Refer to Part 5 (Decals) of this build log for more information. The following photograph shows the placement of the decals. The fuselage sides, top and underside can't be cut as in the previous example. Instead they should be cut by 'trial and error' cutting until you achieve the correctly shaped templates. You can use tracing paper to cut decal templates and check fit them to the model. Then use them a guides to trace and cut the actual decals.

Using the previous example, cut and apply CDL decals to the following fuselage surfaces:

1. Fuselage top and sides (Off White decal).
2. Fuselage underside (CDL decal).
3. Fuselage upper rear sides (PC10 decal).



Kit supplied decals:

The kit supplied decals required are:

Observer cockpit side data 40 (x 2)

Fuselage roundels 1 (x 2)

Fuselage 'Lift Here' 41 (x 2)

Switch direction arrow (42) (fuselage left side - not shown in the instructions).

Apply the kit supplied decals directly onto the 'Aviatic' decals. The rudder decals can be applied to the gloss clear coated rudder.

Painting (continued):

NOTE: *To ensure a colour match it's best to also paint the following parts.*

Airbrush the following parts with a white primer, such as 'AK interactive' White (AK759) or similar.

Fuselage cabane struts (A45, 46, 47 and 48)

Lower wing support struts (B1, 2, 5 and 6)

Tail skid (A54)

Tail skid struts (A59 and 60)

Landing gear struts (A51 and 52).

NOTE: *Refer to the following illustration. **De-tack the masking tape** several times by applying the tape to the skin on your hands. This will remove some of the tape adhesive, making the tape less likely to lift the applied decals when being removed.*



Mask off the fuselage decal areas to leave the PC10 coloured areas exposed (side frames, top panels and observers cockpit panel).

Cut a disc of masking to cover the opening in the observers cockpit.

Mix 'Hataka' black top paint Vert Force (C124) with Medium Green (CO19) to a ration of 50/50 and thin with approximately 35% 'Mr. Colour' self levelling thinner 400.

NOTE: *When airbrushing lacquer based paints, it's usually best to apply a light 'gripper' coat over the parts, in order to provide a good key for subsequent applications of the heavier top coats.*

Airbrush a light 'gripper' coat of the mixed paint over the following:

- Exposed areas of the fuselage
- Engine lower access panel assembly (outer surfaces only)
- Engine upper access panel assembly (outer surfaces only)
- Exposed outer edge of the radiator assembly
- Fuselage cabane struts
- Lower wing support struts
- Tail skid
- Tail skid struts
- Landing gear struts.

Airbrush a top coat of the mixed 'Hataka' paint over all of the above parts.

Remove all masking mediums from the fuselage, taking care not to lift any applied decals with the tape.



Brush paint the following with 'Mr. Colour' Brass (219) or similar:

- Fuselage fuel tank filler cap
- Radiator filler cap
- Magneto starter switch (fuselage left side)
- Fuel selector lever (fuselage left side).

Brush paint the foot steps (fuselage both sides) with 'Mr. Colour' Stainless Steel (213) or similar.

Brush paint the surround padding at the pilots cockpit, with 'AK Interactive' Brown Leather (AK3031).

Lightly airbrush a semi-matte clear coat, such as 'Alclad' Light Sheen (ALC-311) or similar, over the cockpit padding.

Weathering (continued):

NOTE: *Refer to Part 4 (Weathering) of this build log for more information.*

Apply weathering, as desired, to the fuselage metal fittings and louvres. I used 'Flory Models' Dark Dirt fine clay wash.

Once the desired effect is achieved, lightly airbrush coat of a semi-matte clear coat, such as 'Alclad' Light Sheen (ALC-311) or similar, to seal the applied weathering.

Brush 'AK Interactive' Engine oil (AK2019) down the oil tank filler neck.

Brush 'AK Interactive' Kerosene (AK2039) around the fuel tank filler cap.

Dry brush 'Mr. Colour' Super Iron 2 (SM203) at the leading edges of air scoops and over raised details on the engine access panels and the fuselage metal panels.

Decals (continued):

NOTE: *Applying a clear gloss coat is to provide a better surface for applying decals.*

Airbrush the lower part of the engine side access panels with a gloss clear coat, such as 'Alclad' Aqua Gloss 600 or 'Ammo' Aqua Gloss Clear (A.MIG-2503).

Apply the kit supplied data decals 36 (x 2) to the side panels as shown in the following photograph.



Assembly (continued):

Cement the engine lower access panel assembly onto the front of the fuselage, making sure the castellations on the rear edges fully locate together.

Cement the engine assembly into the engine bearers, making sure the four engine mounts locate fully into their engine bearer recesses.

Cement the machine gun tube into its location recess in the top of the engine bulkhead.

Cement the radiator assembly onto the front ends of the engine bearers, the front of the machine gun tube and against the front edges of the lower access panels.

Cement the radiator shutters into the four locating recesses in the front face of the radiator.

Cement the oval radiator cowl onto the front face of the radiator.

Cement the two coolant pipes (E22, E27) into their locating holes in the top, rear of the radiator and against the stubs on the engine coolant pipes.

Cement the ammunition ejection chute (A7) into its locating cut-out in the upper, left of the fuselage.

Cement the filler cap (A18) into its location on the top, right of the fuselage.

Modifications (continued):

NOTE: Now that the basic fuselage is complete, there are other modifications that can be carried out to further enhance the model.

Filler tube:

NOTE: A copper pipe was connected to the fuselage top filler and was routed back and down through the fuselage panel.

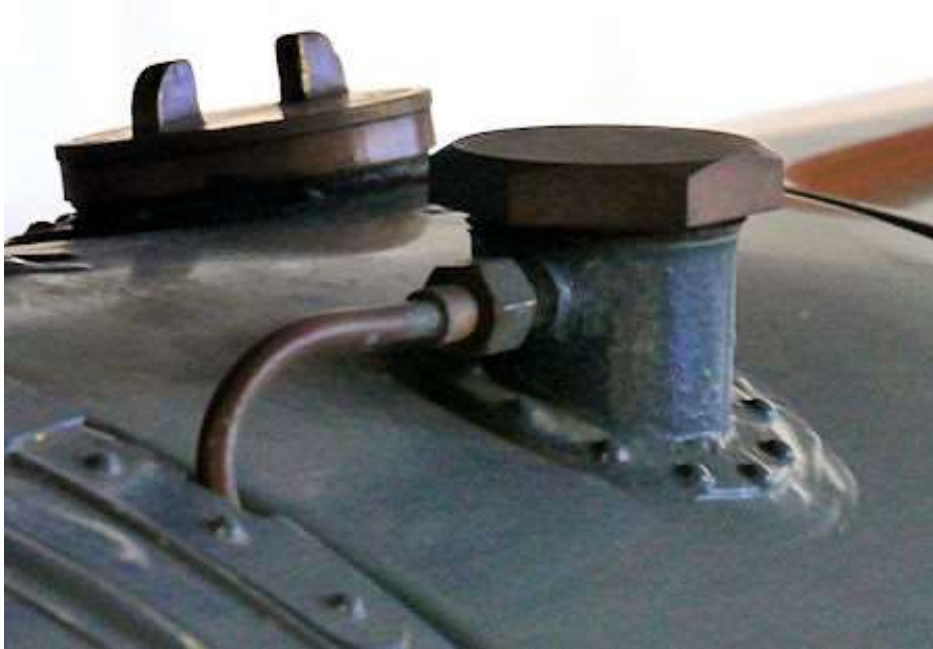

A hole of 0.4 mm diameter was drilled into, **but not through**, the rear of the filler neck and also down through the fuselage panel into the cockpit.

A short length of 0.28 mm diameter Copper wire was cut and annealed (softened over heat).

The wire was bent into position in the pre-drilled holes and secured using thin CA adhesive.



Gun port:

NOTE: The pilots Vickers machine gun fired through a cooling tube fitted along the top of the engine to the rear, top of the radiator. The tube was attached to an opening (gun port) through the radiator. When in flight and the machine gun was fired, the ammunition passed through the weapon barrel inside the cooling tube and out through the gun port in the radiator. The barrel of the weapon was cooled by ram air passing into the gun port and through the cooling tube (around the weapon barrel) then out through the vent fitted on the top of the tube.

The kit supplied radiator has a pre-moulded gun port, but it is solid, not open.



Point mark the centre of the pre-moulded gun port in the front of the radiator.

Using the point mark as a guide, drill a hole of 2.0 mm diameter into, **but not through**, the radiator. Drill the hole in step sizes from 0.5 mm diameter up to 2.0 mm diameter.

Brush paint the inside of the drilled hole with 'Tamiya' Rubber Black (XF85) or similar.

NOTES: The completion of the fuselage is covered in Part 11 (Construction) of this build log.

PART 10

WEAPONS

PART 10 - WEAPONS

NOTE: *When cementing large kit parts, I use 'Revell' Contacta Professional cement (39604). This is a thicker liquid cement, which takes longer to fully set, but does provide a stronger bond between larger kit parts. 'Tamiya' liquid cement is used for smaller parts.*

Before working with or cementing model parts together, make sure all mould seams, sprue tags, mould 'flash', paint or primer is removed from each part.

Refer to the relevant pages in the kit instruction manual.

My sequence of building this model may not follow the kits instruction manual. This is due to incorporating modifications as I progress through the build.

This part of the build log is concerned only with the observers weapons, as the pilots Vickers machine gun was covered in Part 9 (Fuselage) of this build log. Refer to page 18 of the kit instruction manual.

Assembly:

Cement the ammunition drums (D14) onto their locating stubs on the Lewis machine guns (D18).

Cement the two Lewis machine guns onto their mounting bar (A15).

Use thin CA adhesive to secure photo-etch brace (P7) across the machine gun muzzles.

Bend the two photo-etch mounting rails (P4 and P6) as shown on page 18 of the kit instruction manual.

Locate the gun mount (A40) into its two locating lugs on the gun ring (A30).

Locate the two photo-etch mounting rails over the gun mount and into their locating recesses in the gun ring.

Secure the gun rails into the gun ring, using thin CA adhesive.

Position the gun mount, as desired, up the gun rails.

Secure the gun mount to the gun rails, using thin CA adhesive.

Cement the gun mount into its locating lugs on the gun ring.



Painting:

Airbrush the machine guns and mounting assembly with a grey primer, such as 'AK Interactive' Grey (AK758) or similar.

Airbrush the machine guns and mounting assembly with a semi-gloss black, such as 'Tamiya' (X18) or similar.

Airbrush the machine guns with a 'Alclad' Gun Metal (ALC-120) or similar.

Dry brush the machine guns and mounting with 'Mr. Colour' Super Iron 2 (SM203) or similar.

Brush paint the straps on the ammunition drums with 'AK Interactive' Brown Leather (AK3031) or similar.

Brush paint the hand grips of the machine guns with 'Tamiya' Hull Red (XF9) or similar.

Modification:

NOTE: *The observers Lewis machine guns were raised or lowered on their half-hoop mounting. This was made easier by having 'bungee' type cords routed from the base and up and around pulleys.*



Using 'YLI' silk thread #100 (232 or 225), cut two long lengths of either thread and using thin CA adhesive, secure the threads to the base and around the pulleys of the gun mounting half-hoop mounting.



NOTE: *The photo-etch belt (P1) will be painted and added, with the weapons, later in the build log.*

PART 11

CONSTRUCTION

PART 11 - CONSTRUCTION

References:

A very good reference for photographs of the Vintage Aviator Ltd Bristol F.2b can be found at the web site of James Fahey.

<https://jamesfahey.smugmug.com/Bristol-F2B/>

NOTE: *When cementing large kit parts, I use 'Revell' Contacta Professional cement (39604). This is a thicker liquid cement, which takes longer to fully set, but does provide a stronger bond between larger kit parts. 'Tamiya' liquid cement is used for smaller parts.*

Before working with or cementing model parts together, make sure all mould seams, sprue tags, mould 'flash', paint or primer is removed from each part.

Refer to the relevant pages in the kit instruction manual.

My sequence of building this model may not follow the kits instruction manual. This is due to incorporating modifications as I progress through the build.

General preparation:

Some modellers work the various pieces whilst they are still attached to the main sprue, but I prefer to remove the pieces first so that I can clean them up more easily. However pieces like the cockpit frames are delicate and can easily be damaged when being removed. When parts are cut from the sprues, care should be taken as they can either break or get stressed at the cut point, which causes 'white' stress and/or deforming. For plastic kits, I use fine sprue cutters to cut away the kit part, not too close to the part, then sand off the tag. When I cut resin parts away from their mould blocks, I use a fine cutting saw, which has a more gentle cutting action.

Despite being a WNW kit, there are still some fine moulding lines around items such as the cockpit frames, but they are only slight and are easily removed using a sharp blade or sanding stick. I use a new scalpel blade to gently scrape off the mould lines. Some of the model items like the parts for the cockpit are very small and can easily 'fly off' when being handled, so take care. Remember that any rigging holes needed will eventually need to be drilled, by referring to the relevant pages and diagrams in the kit instruction manual and the rigging chapter in this build log.

Primer can be applied by brush, airbrush or from aerosol cans. These days I prefer to use 'AK Interactive' Primer and Micro-filler (Grey AK758) or (White AK759). These have good coverage as the base primer for acrylics. Take care when spraying the primer as if you apply too much it will result in 'pooling' or 'runs', which would then need to be removed once the primer has dried. Make sure you spray in a well ventilated area or preferably, if you have one, use an extractor booth.

To hold items for priming I use self locking tweezers or carefully insert a toothpick into the item or I use a small piece of sticky putty, such as 'UHU White Tack', on the end of a toothpick. Once applied the primer dries quickly, one of the main advantages of using acrylic paints rather than enamels or oil paints.

Modifications:

Ailerons:

Drill holes of 0.6 mm diameter into the trailing edge of the aileron cut-outs in the upper and lower wings. The holes should be drilled centrally between the pre-moulded hinges.

Drill holes of 0.6 mm diameter into the leading edge of the ailerons of the upper and lower wings. The holes should be drilled centrally into the pre-moulded hinges.

Cut lengths of 0.5 mm diameter Brass rod, such as that from 'Albion Models'.

Using thin CA adhesive, secure a cut rod into each of the pre-drilled holes in the upper and lower wings.

Test locate each of the four ailerons onto their respective locating rods. Where necessary, cut away the ends of any of the rods that prevent the aileron locating fully against the wing.

If desired, animate the ailerons in opposition by bending each aileron whilst still located on its rods.. That is the upper and lower ailerons on one side of the wings angled slightly up and the opposite ailerons slightly down. Otherwise, leave the four ailerons aligned to their wings.

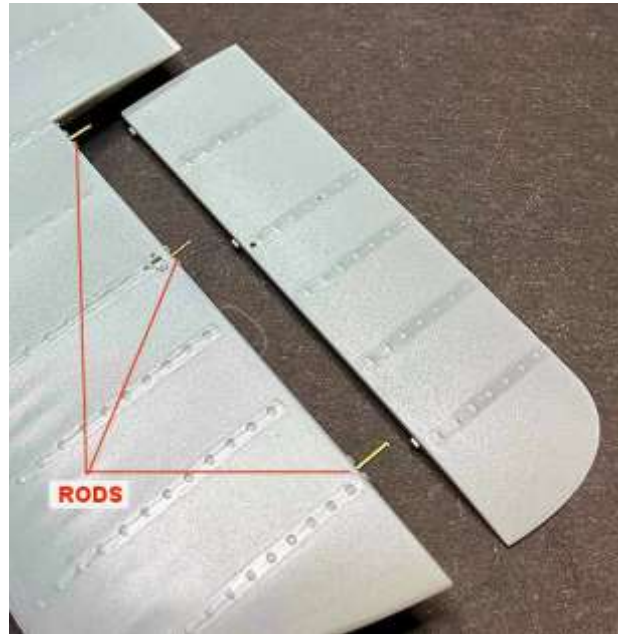

Elevator:

The elevator can be angled slightly down following the same procedure, except the rod used is 0.3 mm diameter and the holes for locating the rods are 0.4 mm diameter. The rod locations are shown in the following photograph.

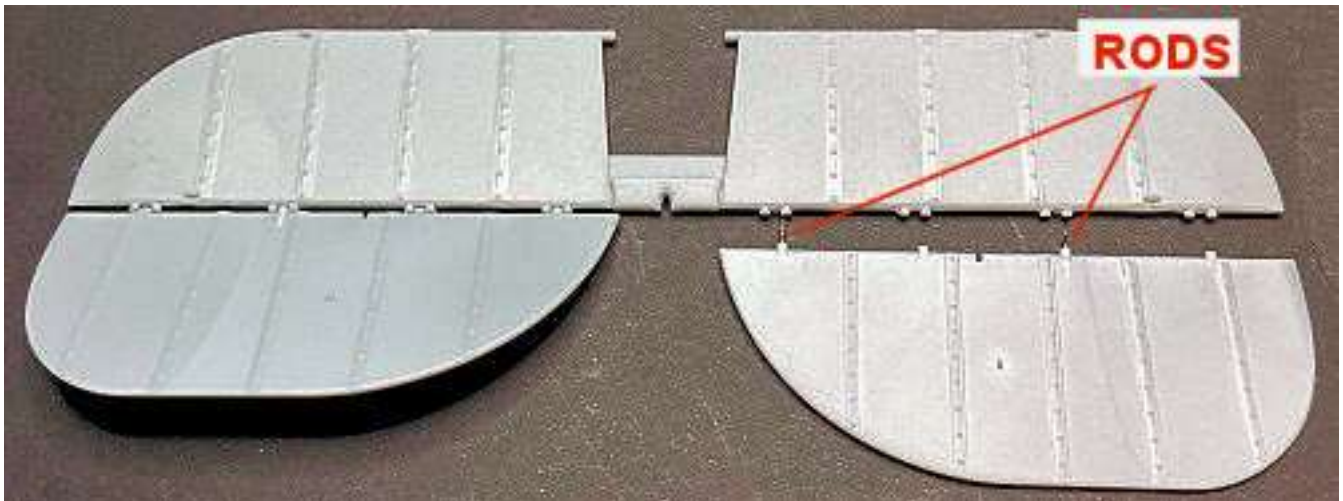

Assembly:

Cement the upper wing centre sections (F4, F5) together.

Cement the upper wings (G1, G4) into the lower wing centre section.

Cement the lower wing centre sections (F9, F10) together.

Cement the lower wings (G2, G3) into the lower wing centre section.

Painting:

Airbrush a white primer, such as 'AK Interactive' White (AK759) or similar over the following parts:

Upper wing and both ailerons

Lower wing and both ailerons

Tailplane

Elevator

Upper and lower fins

Rudder

Both landing gear 'V' struts

Both wheel covers (rear of wheels/tyres)

Both outer wheel covers.

Very lightly sand the painted surfaces to expose the grey styrene underneath. The intention is to create a worn and dirty effect. Sand the following parts:

Between the leading edge ribs and between the primary rib tapes on both sides of the upper and lower wings.

Between the rib tapes of the four ailerons.

Between the rib tapes of the tailplane.

Between the rib tapes of the elevator.

Between the rib tapes of the upper and lower fins.

Between the rib tapes of the rudder.

Lightly airbrush 'Tamiya' Smoke (X19) or similar as follows:

Along the leading and trailing edges of the upper and lower wings.

Along the centre section join seams of the upper and lower wings.

Behind the various attachments and access plates of the upper and lower wings.

Along the leading and trailing edges of the four ailerons.

Along the leading and trailing edges of the tailplane.

Along the leading and trailing edges of the elevator.

Along the rear and lower edges of the upper and lower fins.

Along the front edge of the rudder.

Around the edge of both wheel covers (rear of wheels/tyres)

Around the edge of both outer wheel covers.

Make sure the painted surfaces are smooth and clear of any surface imperfections. If necessary, lightly sand the surfaces to a smooth finish.

NOTE: *Applying a clear gloss coat is to provide a better surface for applying decals.*

Airbrush the following parts with a gloss clear coat, such as 'Alclad' Aqua Gloss 600 or 'Ammo' Aqua Gloss Clear (A.MIG-2503).

Upper wing and both ailerons.

Lower wing and both ailerons.

Tailplane.

Elevator.

Upper and lower fins.

Rudder

Both inner wheel covers (rear of wheels/tyres).

Both outer wheel covers.

Decals:

Example of applying 'Aviatic' decals:

NOTES: *The Clear Doped Linen decals used are the 'Aviatic' (clear backed) decal. The 'Aviatic' linen decals are unlike normal screen printed decals, in that when being applied, have the ability to be handled with slightly less care than normal and they have the ability to stretch slightly, which standard decals do not. That said, if you handle them too roughly, damage can occur.*

Make sure the model surface for each decal to be applied is clean and smooth or particles on the surface may cause 'silvering' (trapped air) under the decals when dry.

The 'Aviatic' decals being used are not 'cookie' cut to the shapes required. Therefore the decals must be hand cut to shape.

Lay the part (with surface to have decal) down onto the rear (blank) side of the decal sheet.

NOTE: *During the following step, do not press too hard when tracing the outline as this may mark the decal side of the sheet.*

Using a pencil, lightly trace the outline of the part onto the rear of the decal, allowing for any curvature of the part, such as wings.

Carefully cut out the decal shape.

Check that the decal fits correctly over the surface of the part.

NOTE: *To aid in adhesion, you can mix a small amount of PVA (white glue) into the decal water.*

Wet the model surface with clean water.

Soak the decal in the warm decal water only until the decal can be moved on its backing sheet.

Carefully lift the decal on its backing sheet from the water. Make sure the decal does not fold over on itself, as it will be difficult to separate a fold once out of the water.

Carefully slide the decal off one end of the backing paper and position the decal end onto the wing and holding that end, slide out the backing paper.

Using large, flat brush or cotton buds, start to smooth out the decal at one end, removing any water from underneath and smoothing the decal onto the surface. Continue this along the length of the decal, taking care not to grip the decal surfaces with your fingers, as this will cause ripples in the decal.

Once the decal is smoothed down onto the model surface, apply pressure along the decal with soft and dry tissue paper or by finger pressure whilst wearing lint free cotton gloves. This will expel any remaining water and press the decal on to the model surface. Check over the decal to make sure there are no tears or folds, which need to be rectified before the decal sets.

NOTES:

*If the decal covers locating holes, slots or other openings, prick through the decal over holes or slice the decal over openings, then brush either 'MicroScale' MicroSol' or **very sparingly** 'Tamiya' X20A thinners, into the holes or around the openings. This will soften and conform the decal. Too much X20A will **melt** the decal.*

*If the decal needs to be conformed around curved edges etc, brush **very sparingly** 'Tamiya' X20A thinners across the decal edge. This will soften and conform the decal.*

Once fully dry and set, trim any excess decal from edges using a sharp blade, such as a shielded razor blade.

Application:

NOTES: The decals used to cover the flight surfaces are the 'Aviatic' Off White Linen (ATT32241), Clear Doped Linen (CDL) (ATT32044) and PC10 Medium (ATT32090).

Refer to the following photograph for placement of the decals.

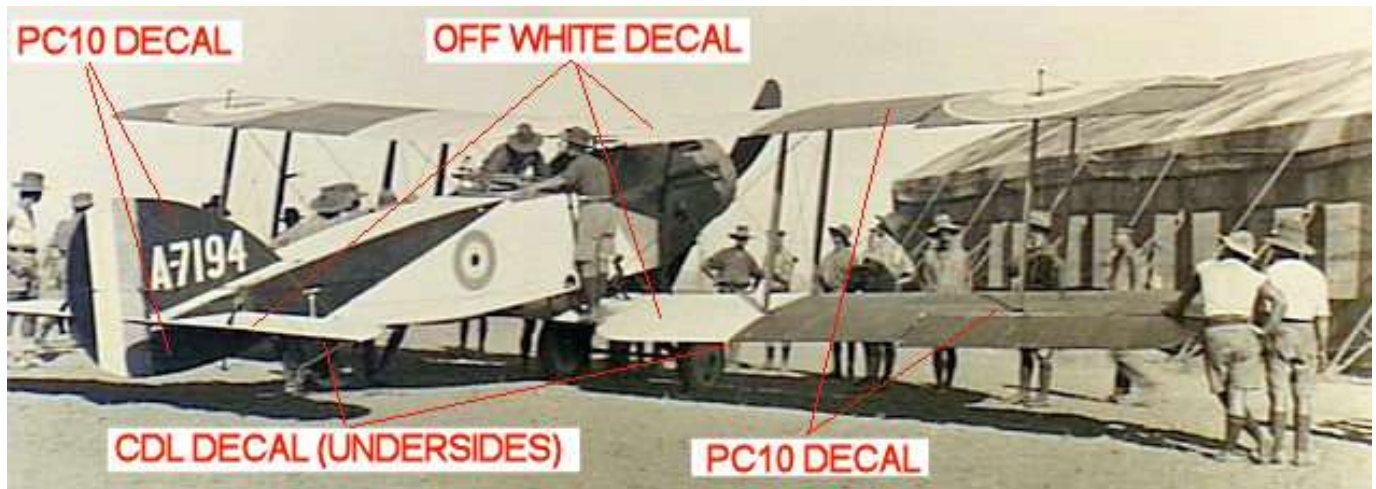

Using the previous example, cut and apply CDL decals to the following model parts:

1. Underside of upper and lower wings, ailerons, tailplane and elevator (CDL decal).
2. Top of upper wing and ailerons (Off White decal).
3. Top of lower wing and ailerons (Off White decal).
4. Top of tailplane and elevator (Off White decal).
5. Outer and inner wheel covers (Off White decal).
6. Top of upper wing and ailerons (PC10 decal).
7. Top of lower wing and ailerons (PC10 decal).
8. Upper and lower fins (PC10 decal).

1, 2 and 3.

NOTE: Due to the large size of the wings, the wing decals are best cut as several separate decals. They should be cut until you achieve the correctly shaped templates. You can use tracing paper to cut decal templates and check fit them to the model. Then use them a guides to trace and cut the actual decals.

5.

NOTE: I used a 'ThinnerLine Circle Cutter' to create circular decals from the 'Aviatic' sheet for the wheel covers.



Using the cutter to cut two circular decals for the rear wheel covers and two decals for the front covers (Off White decal).

NOTE: The front wheel covers are slightly conical in shape. The decals need to be cut slightly larger in diameter than required then a section cut out. This will allow the decal to be applied to the conical surface with the cut sides butting against each other.

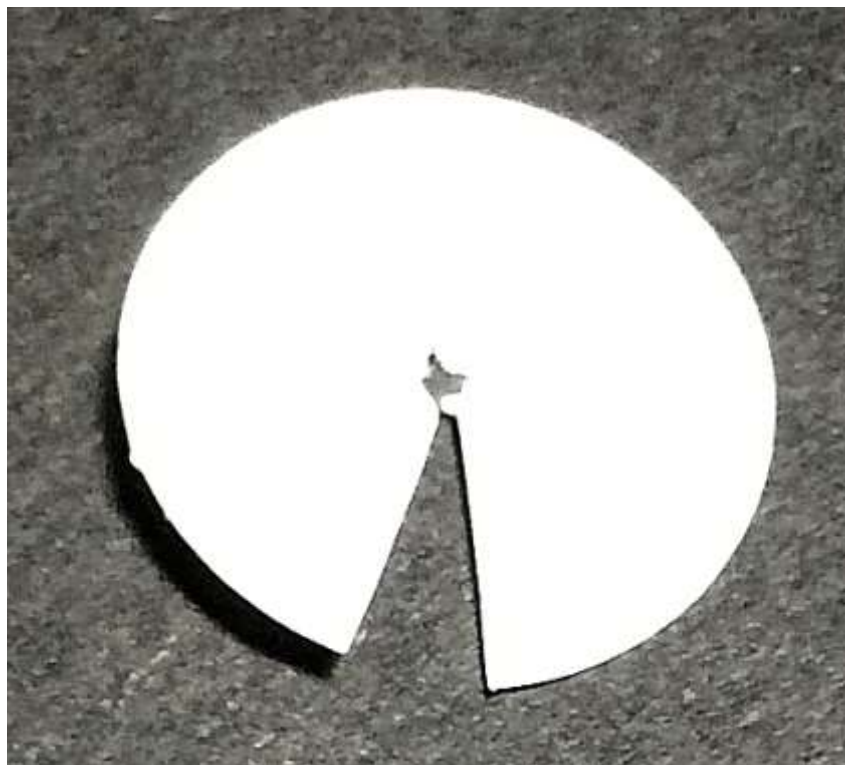

Kit supplied decals:

NOTE: Refer to the colour profiles in the kit instructions for the locations of the required kit supplied decals. The kit supplied decals required (which can be applied directly onto the 'Aviatic' decals) are as follows:

Upper wing roundels 4 (x 2)

Lower wing roundels 5 (x 2)

Rudder stripes 8 and 9

Rudder Logo 35 (x 2)

Serial data 37 (x 8) and 38 (x 6)

Upper fin logo 37 (x 2)

Lower fin logo 38 (x 2).

Apply the required decals to the wings, rudder, tailplane, fins and elevator .

NOTES:

As the wing ailerons have been modified to be 'animated' the wing roundels need to be cut along between the trailing edge of the wing and leading edge of the ailerons.

The rudder stripes (decal 8 and 9) are oversized for the rudder. Therefore I cut away the red and blue stripes from the decals to remove the white stripe (the rudder is already painted white). The red and blue stripes were then applied to the rudder.

Painting (continued):

NOTE: The aircraft white serial numbers A-7194 are not supplied in the kit.

The serial number A-7194 was copied from the colour profile by R. Pearson (2005) and resized and 'cleaned up' using 'Corel' Paint Shop Pro Ultimate 2023 software.

This was then uploaded into the software for a 'Cricut' Explore Air 2 crafters cutter.

Masks of the serial numbers were then cut into 'Tamiya' masking sheet.

The masks were then used to airbrush 'Hataka' Insignia White (Orange line - CO49) to create the serial numbers onto each side of the upper fin.

Top surface of upper wing

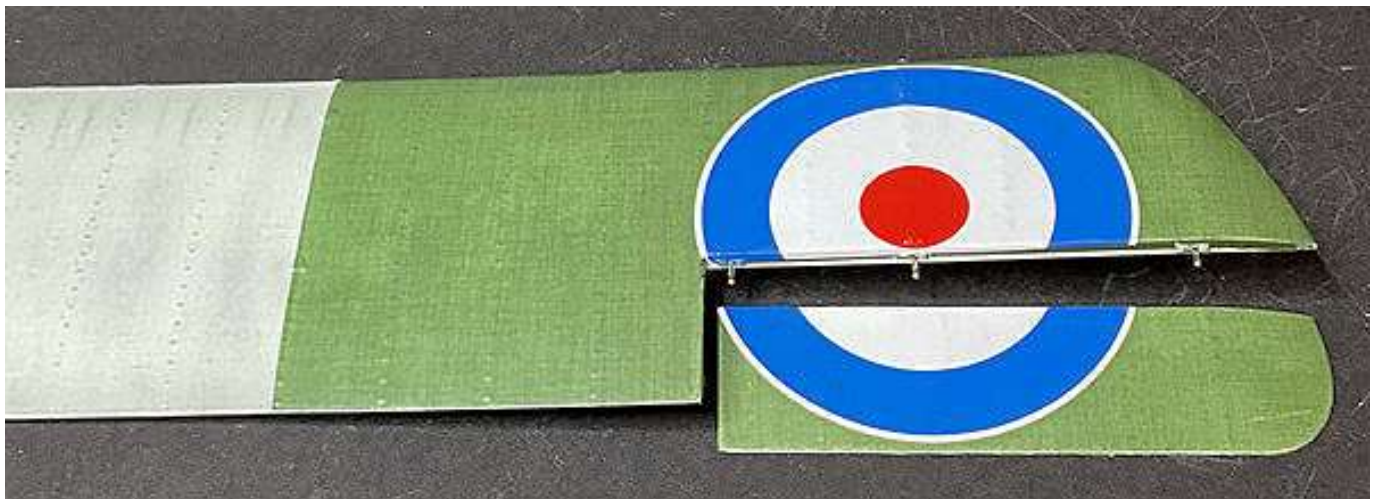

Underside of upper wing

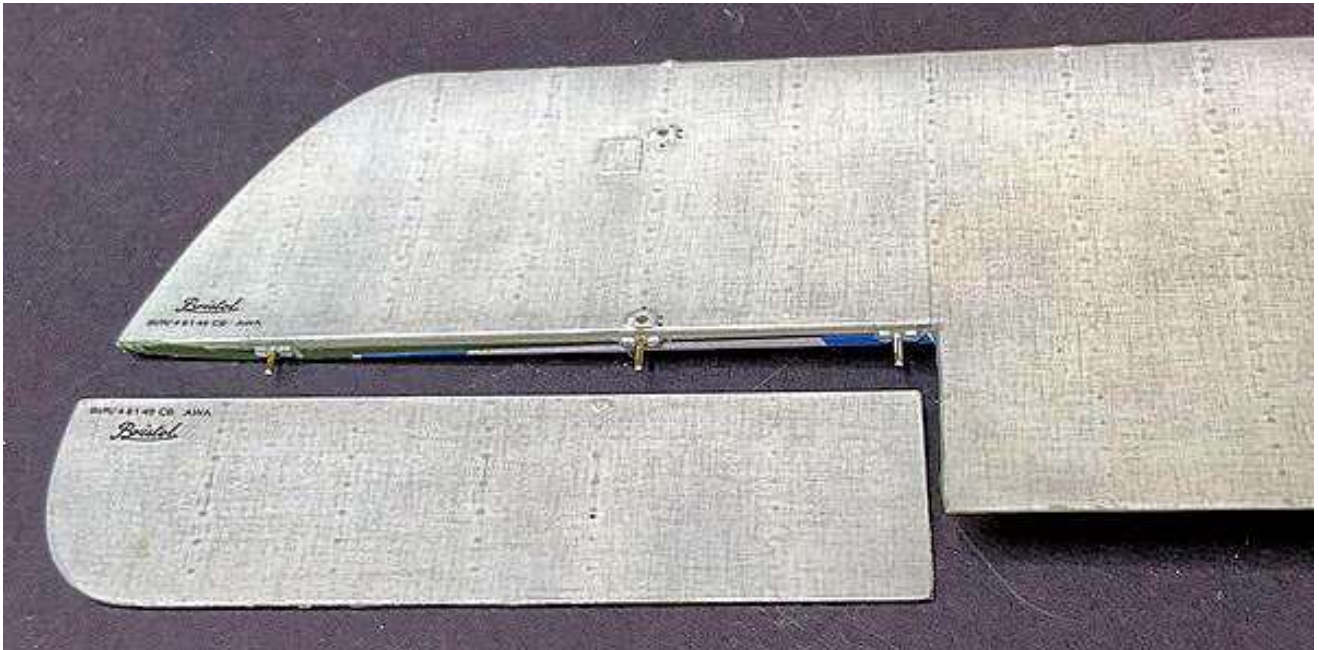

Top surface of lower wing

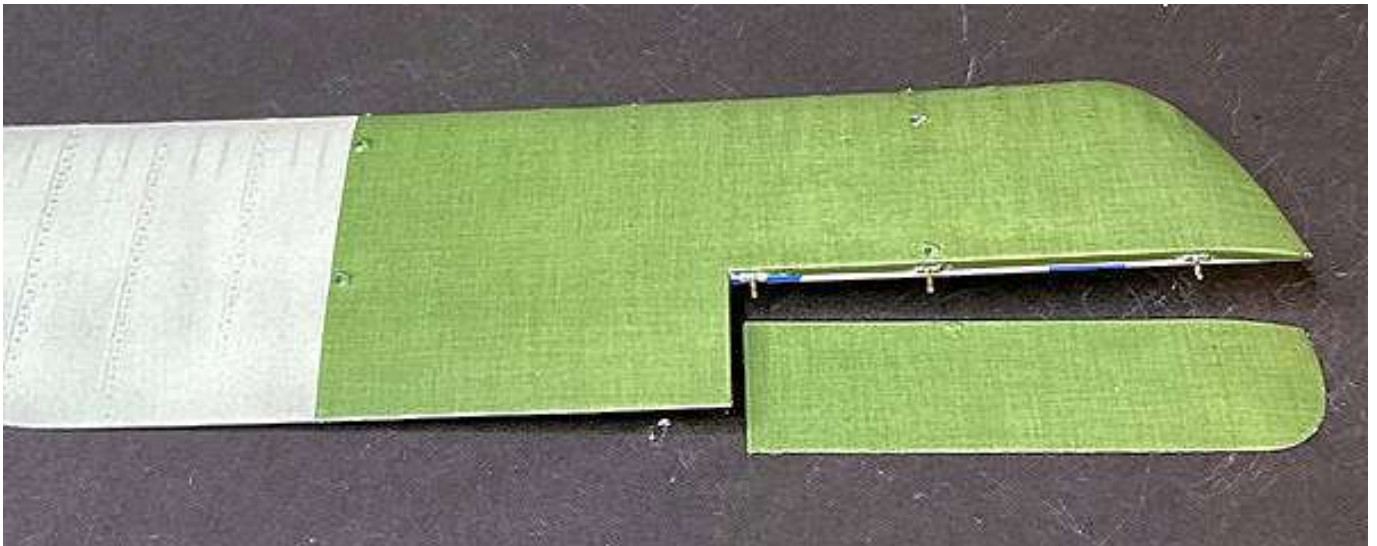

Underside of lower wing

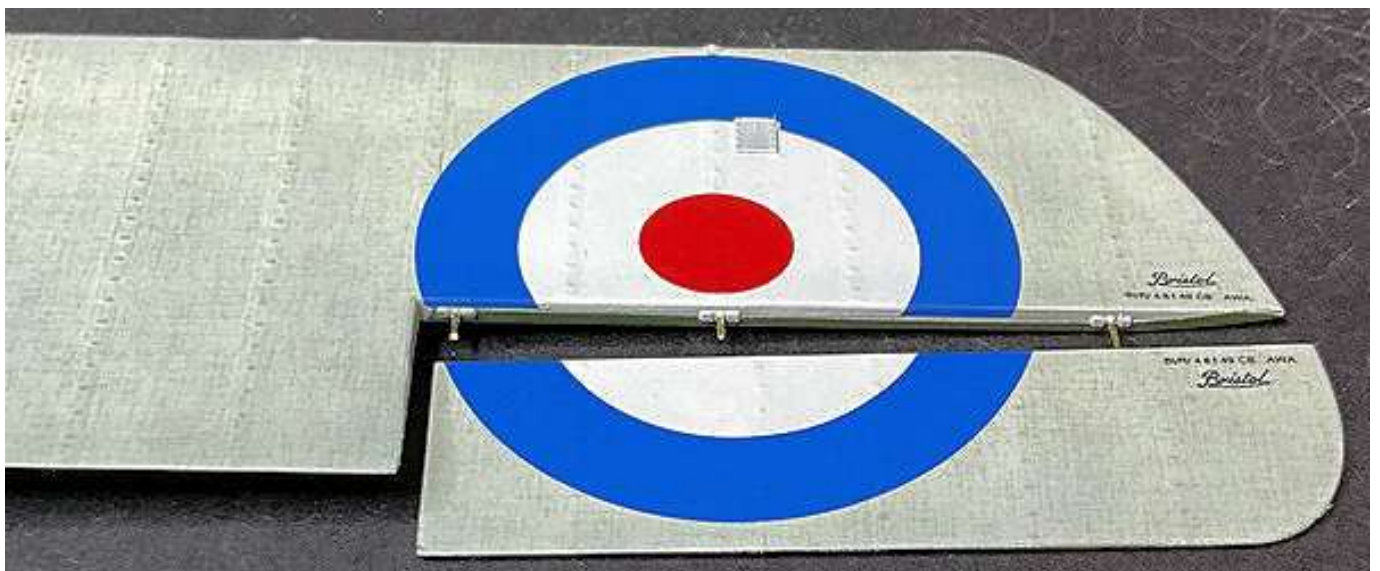

Top surfaces of tailplane and elevators

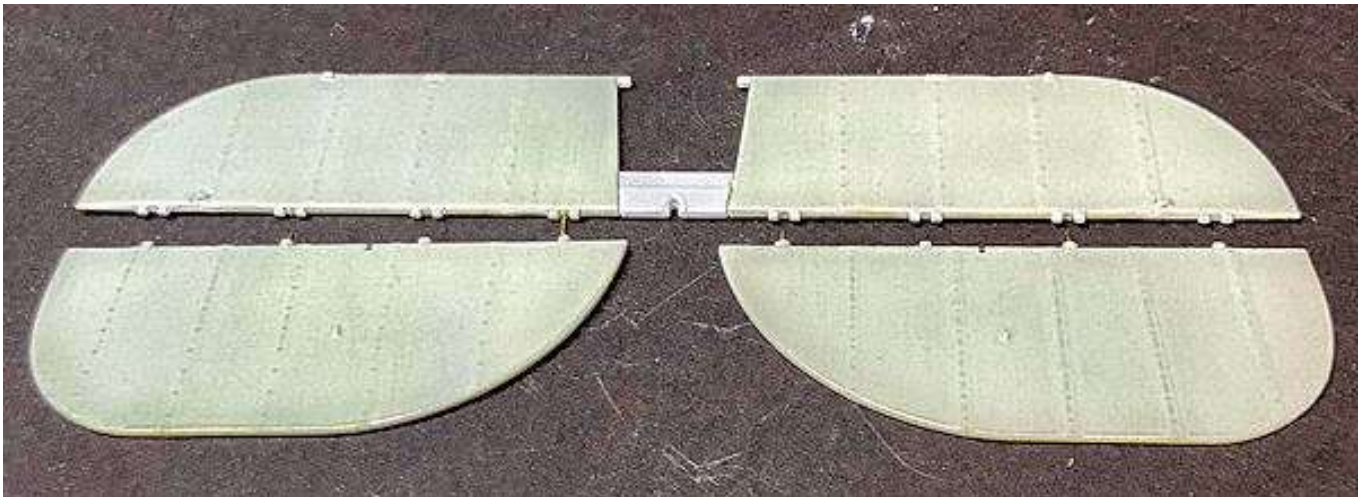

Underside of tailplane and elevators

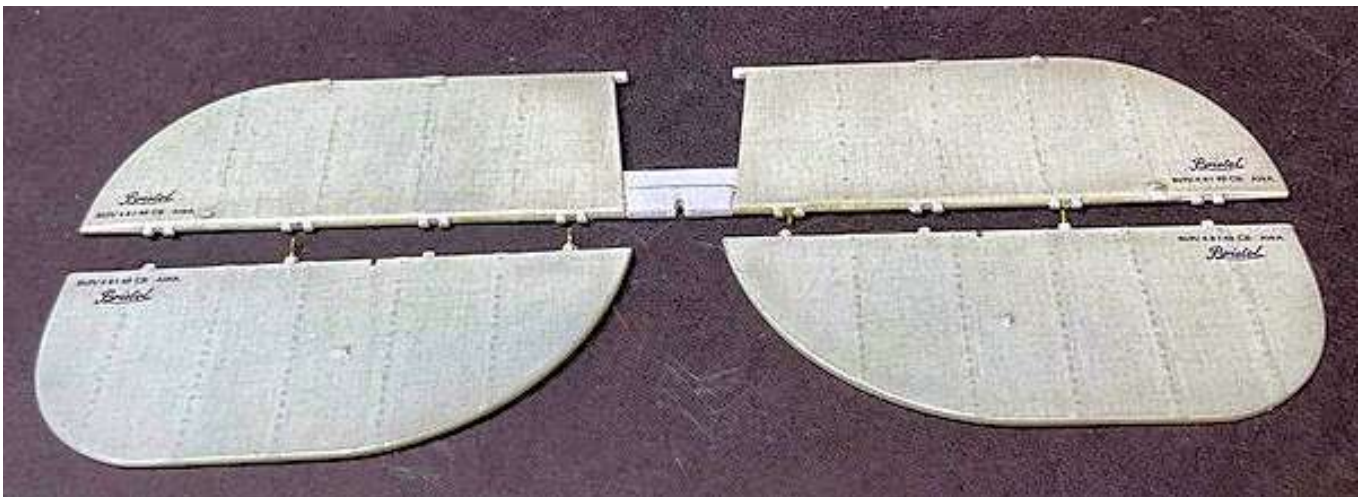

Rudder and fins



Weathering:

NOTE: *The following is intended to create a 'sand worn' effect over the aircraft, as it operated in the Palestine theatre.*

Mix 'Tamiya' Desert Yellow (XF59) with a semi-matte clear coat, such as 'Alclad' Light Sheen (ALC311) or similar. The ration of the mix should be 50/50%. Thin the mixture with approximately 30% 'Mr. Colour' self levelling thinner 400.

Lightly airbrush the mixed paint over the following:

- Upper and lower wings
- Upper and lower wing ailerons
- Upper and lower fins
- Rudder
- Tailplane
- Elevators
- Fuselage.

Airbrush a semi-matte clear coat, such as 'Alclad' Light Sheen (ALC311) or similar, over the following:

- Upper engine panels assembly
- Lower engine access panels assembly
- Radiator assembly
- Landing gear struts.

NOTE: *Refer to Part 4 (Weathering) of this build log for more information.*

Apply weathering, as desired, to the parts. I used 'Flory Models' **Sand** fine clay wash.

Once the desired effect is achieved, lightly airbrush coat of a semi-matte clear coat, such as 'Alclad' Light Sheen (ALC-311) or similar, over the parts to seal the applied weathering.

Use 'AK Interactive' weathering pencil (Sand 10009) to lightly highlight the rib tapes on all of the Clear Doped Linen decals and around the edges of the fuselage stitching.

Use 'AK Interactive' weathering pencil (Smoke 10003) to lightly highlight the rib tapes on all of the PC10 linen decals.





Painting (continued):

Airbrush the following parts with a grey primer, such as 'AK Interactive' Grey (AK758) or similar:

NOTE: Mask off the applied decals on the two wheels (D8).

Tyres of the two wheels (D8 x 2)

Elevator control levers (D15 x 2)

Landing gear axle (A10)

Blade of Rotherham pump (A11)

Interplane struts (D7 x 4)

Interplane struts (D6 x 3)

Interplane strut (A43)

Rudder control horn (A6)

Aileron control horns (D13 x 2)

Aileron control horns (D19 x 2)

Compass housing (A57)

Wing hoops (D2 x 2)

Elevator control horns (D12 x 2)

Fuselage control rod (A55)

'Aldis' gun sight (A44).

Airbrush the following parts with 'Tamiya' Dark Yellow (XF60) or similar:

- Blade of Rotherham pump (A11)
- Interplane struts (D7 x 4)
- Interplane struts (D6 x 3)
- Interplane strut (A43)
- Wood on tail skid (A54).

Wood effects:

NOTE: Refer to Part 3 (Wood Effects) of this build log for more information. The method I used is Method 2, using 'Windsor & Newton' Griffin (Alkyd) Raw Sienna oil paint.

Apply the wood effect onto the following:

- Blade of Rotherham pump (A11)
- Interplane struts (D7 x 4)
- Interplane struts (D6 x 3)
- Interplane strut (A43)
- Wood on tail skid (A54).

Brush a covering coat of the 'Windsor & Newton' Griffin (Alkyd) Raw Sienna oil paint over the parts.

Leave the oil paint to settle for several minutes.

Decant a small amount of White Spirits or Odourless thinners into a suitable dish.

Dip a flat oil brush into the thinners then wipe the brush on a sheet of kitchen roll (which should not deposit any fibres in the oil paint) to remove most of the thinners.

Brush the oil paint onto the part in the required direction of the wood grain and keep wiping the brush on the sheet to remove residual oil paint.

Repeat dipping and wiping the brush in the thinners and brushing the oil paint until the desired density and effect is achieved.

Leave the oil paint to fully dry. It should be touch dry in an hour or so and fully dry within 12 hours.

Airbrush a gloss clear coat, such as 'Alclad' Aqua Gloss 600 or 'Ammo' Aqua Gloss Clear (A.MIG -2503) over the central area of the eight interplane struts.

Painting (continued):

Airbrush the following parts with 'Tamiya' Rubber Black (XF85) or similar:

- Elevator control levers (D15 x 2)
- Landing gear axle (A10)
- Rudder control horn (A6)
- Aileron control horns (D13 x 2)
- Aileron control horns (D19 x 2)
- Wing hoops (D2 x 2)
- Elevator control horns (D12 x 2)
- Compass face (A57)
- Fuselage control rod (A55)
- 'Aldis' gun sight (A44).

Brush the following parts with 'Tamiya' Rubber Black (XF85) or similar:

- Metal fittings on upper fin (F2)
- Metal fittings on lower fin (F6)
- Pitot tubes on interplane strut (A43)
- Metal fittings on the tail skid (A54)
- Metal fittings on upper wing
- Metal fittings on lower wing
- 'Rotherham' pump support brackets (on strut A52).

Brush paint 'Tamiya' Clear Yellow (X24) onto the ends of the 'Aldis' gun sight (A44).

Brush paint the following with 'Tamiya' Buff (XF55) or similar:

- 'Bungee' suspension cords around the bottom of the two landing gear struts (A51, A52)
- Ends of the eight interplane struts with 'Tamiya' Buff (XF55) or similar
- Tail skid (A54) suspension cords.

Brush 'AK Interactive' Kerosene wash (AK3029) over the suspension cords.

Brush paint the aileron control access panels on the undersides of the upper and lower wings and the side panels on the lower wing centre section with 'Mr. Colour' Stainless Steel (213) or similar.

Brush paint the body of the 'Rotherham' pump with 'Mr. Colour' Brass (219) or similar.

Dry brush any of the metal fittings (painted black) with 'Mr. Colour' Super Iron 2 (SM203) or similar.

Assembly (continued):

Cement the compass housing (A57) into its recess in the centre, trailing edge of the upper wing.

Cement the control rod (A55) into its locating holes in the underside of the fuselage.

Cement the 'Aldis' gunsight (A44) into its locating holes in the central underside of the upper wing.

Kit decals (continued):

NOTE: Refer to page 9 of the instruction manual for the strut positions.

Apply the 'Bristol' logo decals (a) midway up the **both sides** of the eight interplane struts.

Apply the tyre decals (39 x 4) to the same location on both sides of the wheel tyres.

As the kit does not specify a decal to represent the compass face, I cut one from a spare 'Airscale' WW1 generic instrument set and applied it to the compass face. Once set, I applied 'Tamiya' Clear Orange (X24) over the decal.

Finish:

Airbrush a final light sealing coat of semi-matte clear coat, such as 'Alclad' Light Sheen (ALC-311) or similar, over all of the painted and decal parts.

PART 12
PREPARATION
FOR EXTERNAL
RIGGING

PART 12 - PREPERATION FOR EXTERNAL RIGGING

References:

A very good reference for photographs of the Vintage Aviator Ltd Bristol F.2b can be found at the web site of James Fahey.

<https://jamesfahey.smugmug.com/Bristol-F2B/>

NOTE: *The following modifications will allow rigging of the external flight controls and structural rigging to be applied. Refer to Part 6 (Rigging - General) and page 19 of the instruction manual for information on the rigging of this aircraft.*

Rigging locating holes:

Elevator control cables:

Drill holes of 0.3 mm diameter through the ends of the elevator levers (D15 x 2) and control horns (D12 x 2).

Drill a hole of 0.3 mm diameter through the two elevators, at the pre-moulded stubs.

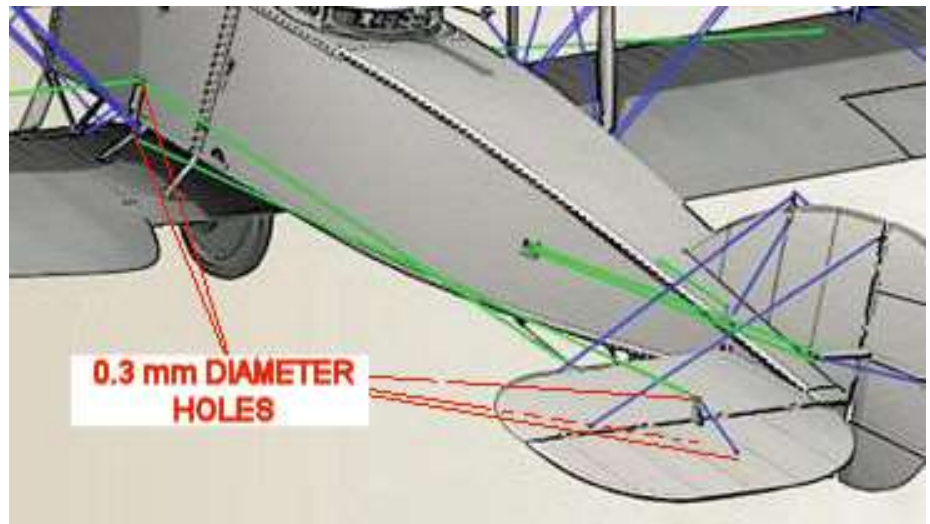

Tailplane adjustment cables:

Drill a hole of 0.3 mm diameter through the top of the fuselage, towards the outer edges and aligned to the front of the upper fin (when fitted).

Drill a hole of 0.3 mm diameter through the bottom of the fuselage, towards the outer edges and aligned to the front of the lower fin (when fitted).

Use thin CA adhesive to secure the four photo-etch levers (P5) into their slots in the rear edges of the fuselage. The vertical edge of the levers should be at the front of the slots.

Brush paint the exposed levers with 'Tamiya' Rubber Black (XF85) or similar.

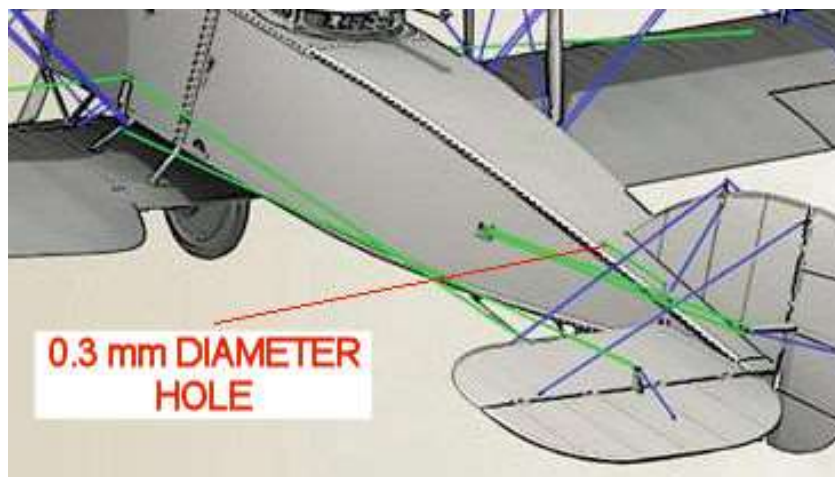

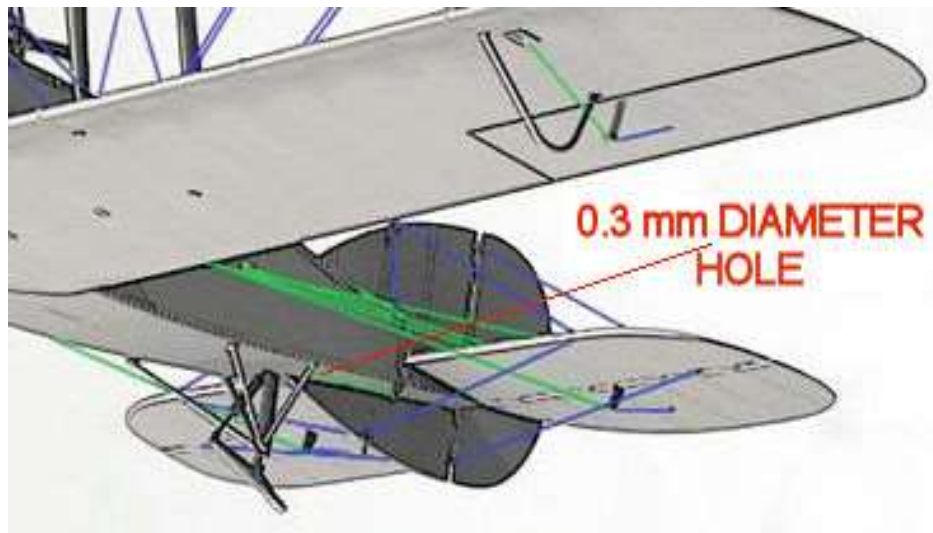

Rudder control cables:

Drill a hole of 0.3 mm diameter through the forward ends of the rudder control horn (A6).

Drill a hole of 0.3 mm diameter through the rear ends of the rudder control horn (A6).

Drill a hole of 0.3 mm diameter through the rudder at the pre-moulded stubs.

Make sure the control cable exit ports in the fuselage side are clear of decal.

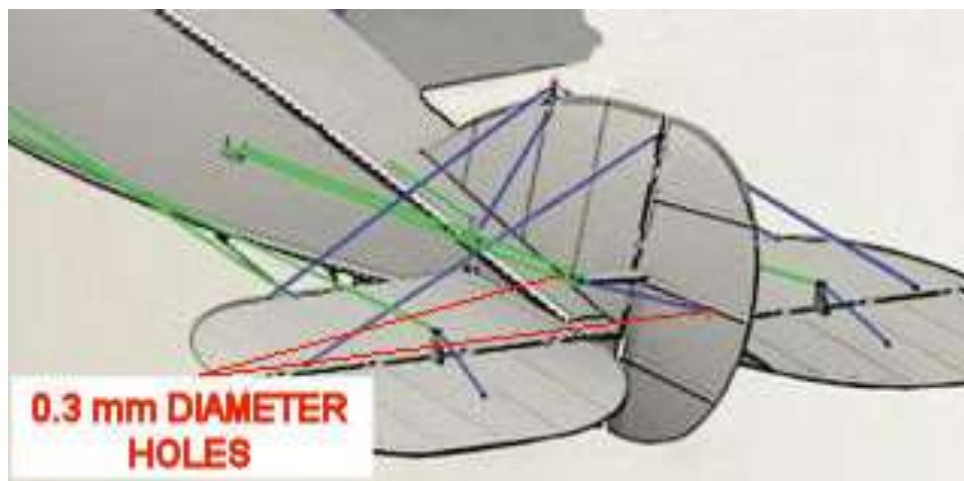

Aileron control cables:

Drill a hole of 0.3 mm diameter through the ends of the upper aileron control horns (D13 x 2).

Drill a hole of 0.3 mm diameter through the ends of the lower aileron control horns (D19 x 2).

Drill a hole of 0.3 mm diameter through each of the four ailerons at the pre-moulded recesses.

Drill a hole of 0.3 mm diameter into, **but not through**, the top of the upper wings, 6 mm back and outboard from the forward interplane mounting. The holes should be drilled at an angle so as to align with the top of the upper aileron control horns (when fitted).

Drill a hole of 0.3 mm diameter into, **but not through**, the underside of the lower wings, at the rear of the pre-moulded aileron control access panels. The holes should be drilled at an angle so as to align with the top of the lower aileron control horns (when fitted).

Drill a hole of 0.3 mm diameter into, **but not through**, the top of the lower wings, inboard from the forward, outer interplane struts. The holes should be drilled at an angle so as to align with the aileron cable exit ports in the sides of the fuselage, above the elevator control levers.

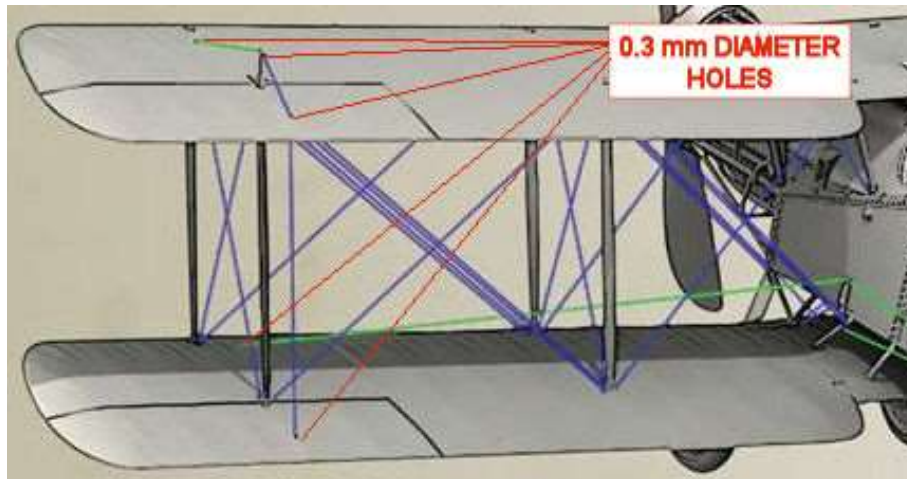

Forward twin flying wires:

Drill two holes of 0.3 mm diameter in the bottom edge of the fuselage, above the locating recesses for the landing gear forward struts. The holes should be drilled with their centres approximately 1.0 mm apart and an angle so as to align with the top of the forward, inboard interplane struts (when fitted).

Drill two holes of 0.3 mm diameter into, **but not through**, the underside of the upper wing at the pre-moulded locating recesses inboard from the forward, inboard interplane strut locations. The holes should be drilled so as to align with the pre-drilled holes for the landing gear forward struts.

Drill two holes of 0.3 mm diameter into, **but not through**, the top of the lower wings at the pre-moulded locating recesses outboard from the forward, inboard interplane strut locations. The holes should be drilled so as to align with the top of the forward, outboard interplane struts (when fitted).

Drill two holes of 0.3 mm diameter into, **but not through**, the underside of the upper wing at the pre-moulded locating recesses inboard from the forward, outboard interplane strut locations. The holes should be drilled so as to align with the pre-drilled holes in the lower wings, outboard from the forward, inboard interplane struts.

Rear twin flying wires:

Repeat the previous procedure, except for the following:

The fuselage holes should be drilled above the locating recesses for the landing gear rear struts, to the rear of the locating hole for the elevator control lever.

The holes in the upper and lower wings should be drilled at the locations for the rear inboard and outboard interplane struts.

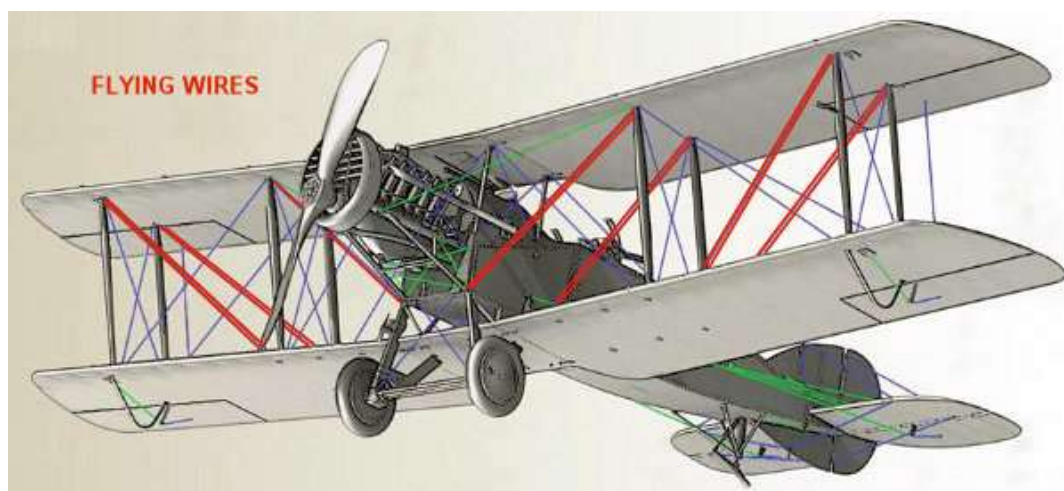

Forward single landing wires:

Drill a hole of 0.3 mm diameter into, **but not through**, the underside of the upper wing at the pre-moulded locating recesses outboard from the forward, fuselage cabane strut locations. The holes should be drilled so as to align with the bottom of the forward, inboard interplane struts (when fitted).

Drill a hole of 0.3 mm diameter into, **but not through**, the top of the lower wing at the pre-moulded locating recesses inboard from the forward, inboard interplane strut locations. The holes should be drilled so as to align with the pre-drilled holes in the underside of the upper wing (when fitted).

Drill a hole of 0.3 mm diameter into, **but not through**, the underside of the upper wing at the pre-moulded locating recesses outboard from the forward, inboard interplane strut locations. The holes should be drilled so as to align with the bottom of the forward, outboard interplane struts (when fitted).

Drill a hole of 0.3 mm diameter into, **but not through**, the top of the lower wing at the pre-moulded locating recesses inboard from the forward, outboard interplane strut locations. The holes should be drilled so as to align with the pre-drilled holes in the underside of the upper wing (when fitted).

Rear single landing wires:

Repeat the previous procedure, except for the following:

The locating holes at the cabane strut in upper wing should be drilled outboard from the fuselage rear cabane strut locations.

The remaining holes in the upper and lower wings should be drilled at the locations for the rear inboard and outboard interplane struts.

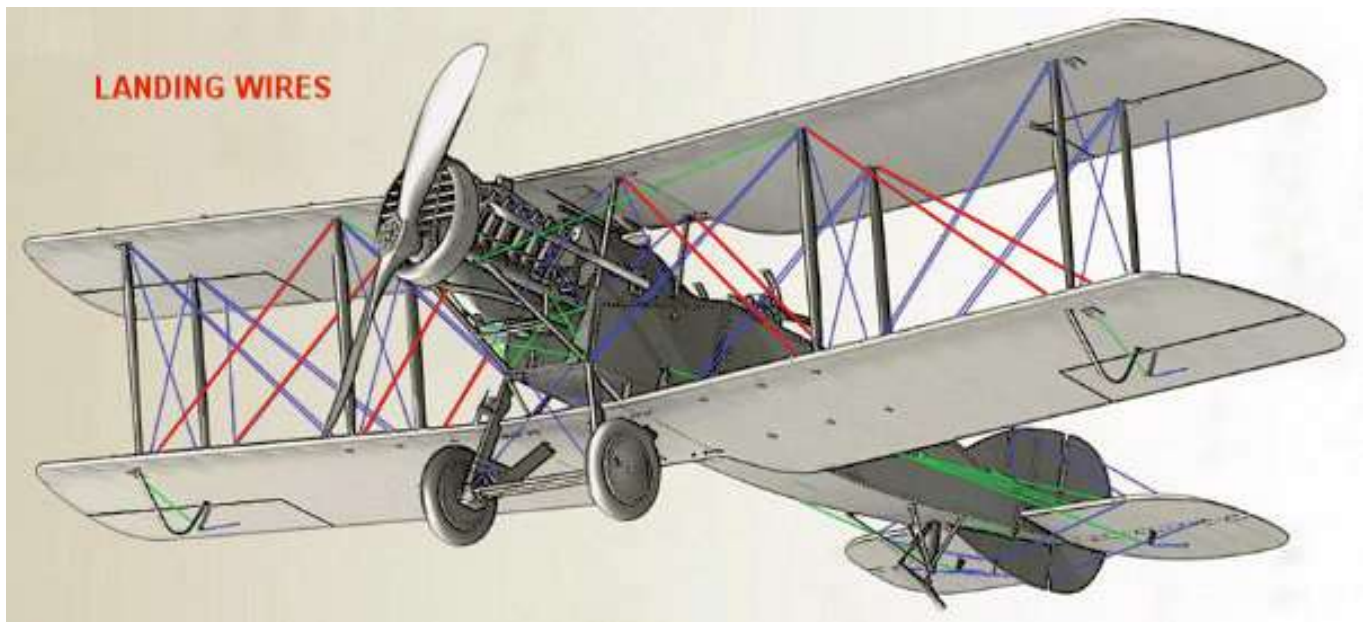

Fuselage cabane strut bracing wires:

NOTE: *The cabane strut side bracing wires are diagonally crossed.*

Drill a hole of 0.3 mm diameter into, **but not through**, the underside of the upper wing at the pre-moulded locating recesses rear of the forward cabane strut location. The holes should be drilled so as to align with the bottom of the rear cabane struts at the fuselage (when fitted).

Drill a hole of 0.3 mm diameter into the fuselage at the pre-moulded recess forward from the rear cabane strut location. The holes should be drilled to align with the pre-drilled holes at the forward cabane strut locations in the underside of the upper wing.

Drill a hole of 0.3 mm diameter into, **but not through**, the underside of the upper wing at the pre-moulded locating recesses forward from the rear cabane strut location. The holes should be drilled so as to align with the pre-moulded slot in the fuselage, rear of the bottom of the forward cabane struts at the fuselage.

Drill a hole of 0.3 mm diameter into the fuselage at the rear of the forward cabane strut location. The holes should be drilled to align with the pre-drilled holes at the rear cabane strut locations in the underside of the upper wing.

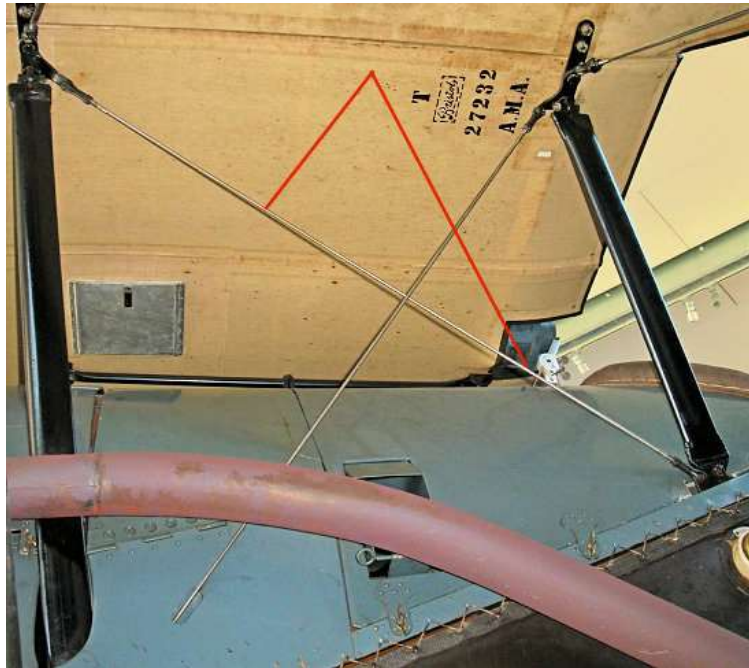

Drill a hole of 0.3 mm diameter into, **but not through**, the underside of the upper wing at the pre-moulded locating recesses inboard from the forward cabane strut locations. The holes should be drilled to align with pre-moulded slots in the rear edge of the engine upper access panels when located on the model.



Landing gear bracing wires:

NOTE: *The landing gear bracing wires are diagonally crossed.*

Drill a hole of 0.3 mm diameter through the pre-moulded recess at the top of the forward of the landing gear struts. The holes should be drilled to align with the forward, bottom of the landing gear struts (when fitted).

Drill a hole of 0.3 mm diameter through the side of the forward, top of the base of the landing gear struts. The holes should be drilled to align with pre-drilled holes in the top of the forward struts.

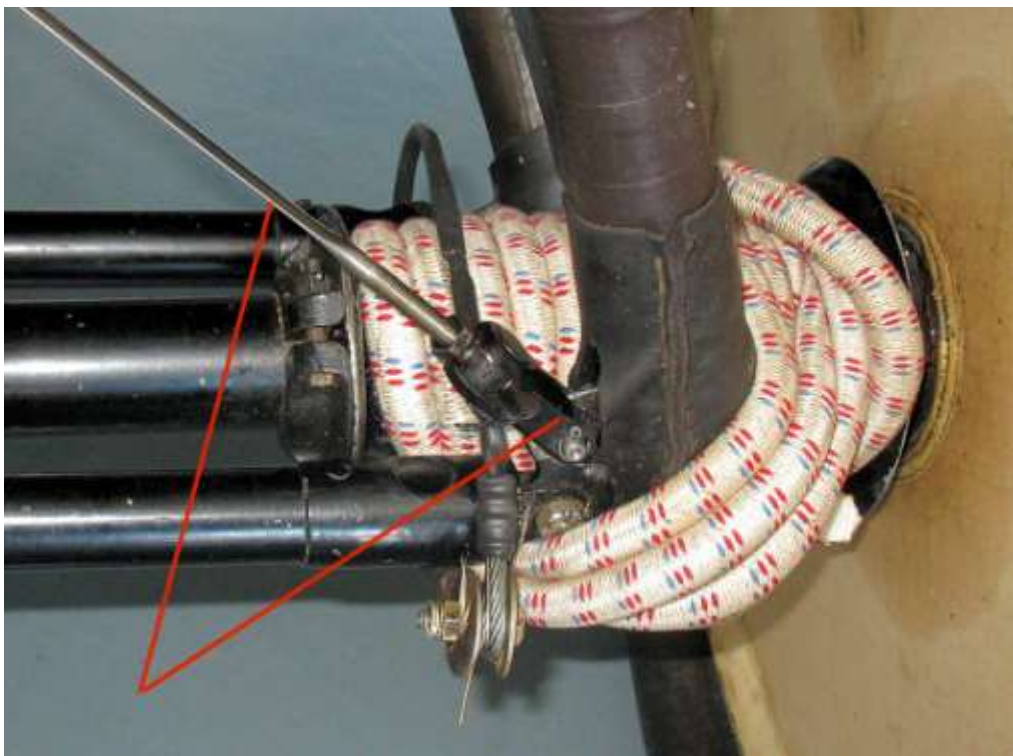
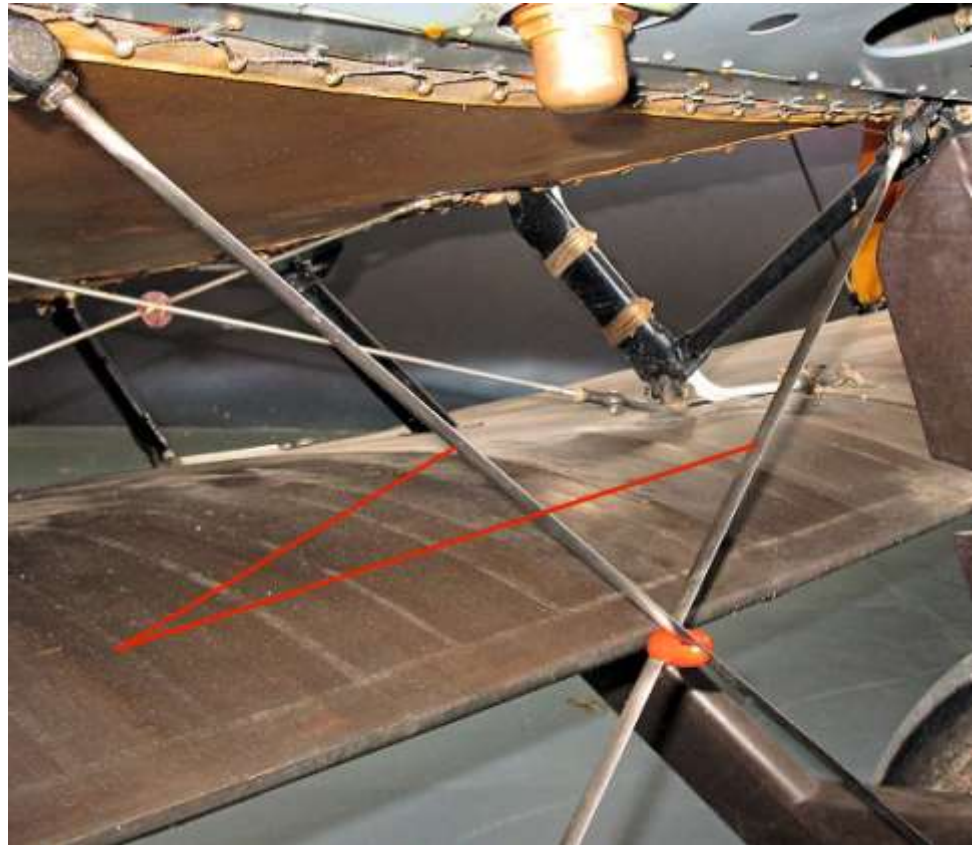

Interplane strut bracing wires:

NOTE: *The following procedure applies to all four pairs of interplane struts.*

Drill a hole of 0.3 mm diameter into, **but not through**, the underside of the upper wing, at the pre-moulded recess to the rear of the forward interplane strut location. The hole should be drilled to align with the bottom of the rear interplane strut (when fitted).

Drill a hole of 0.3 mm diameter into, **but not through**, the top of the lower wing, at the pre-moulded recess forward from the rear interplane strut location. The hole should be drilled to align with the pre-drilled hole at the underside of the upper wing at the forward interplane strut (when fitted).

Drill a hole of 0.3 mm diameter into, **but not through**, the underside of the upper wing, at the pre-moulded recess forward from the rear interplane strut location. The hole should be drilled to align with the bottom of the forward interplane strut (when fitted).

Drill a hole of 0.3 mm diameter into, **but not through**, the top of the lower wing, at the pre-moulded recess rear of the rear forward strut location. The hole should be drilled to align with the pre-drilled hole at the underside of the upper wing at the rear interplane strut (when fitted).

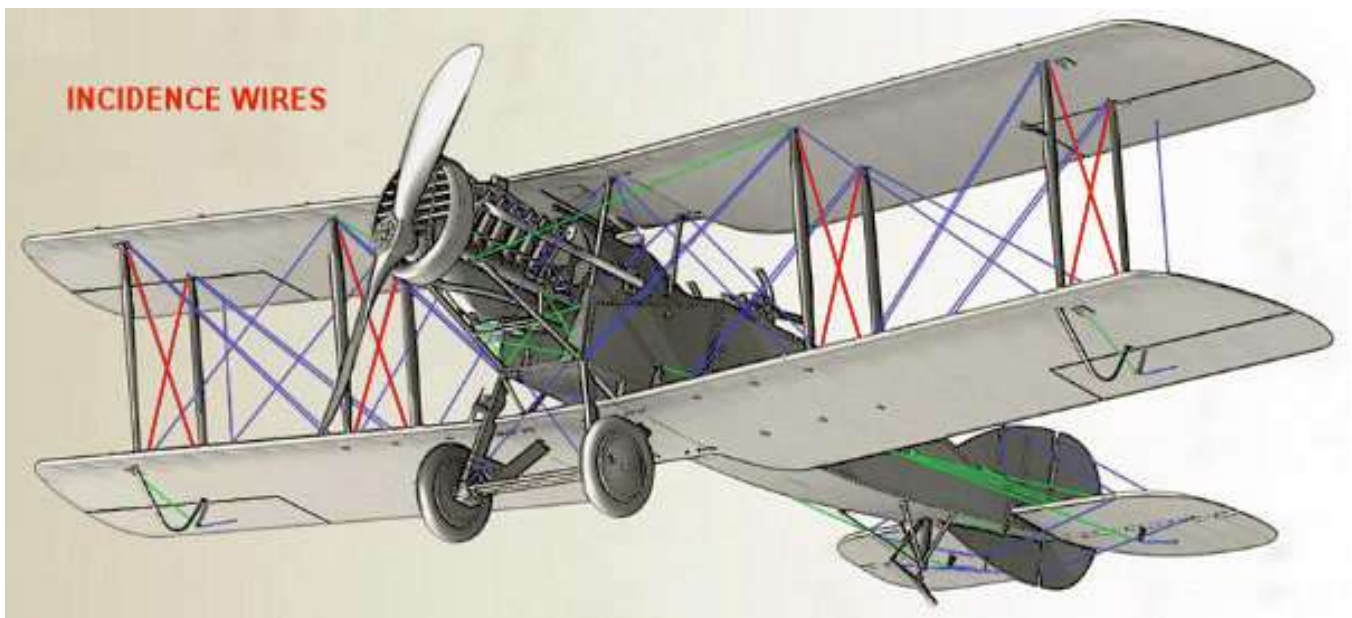

Tailplane bracing wires:

Drill a hole of 0.3 mm diameter through the tailplane at the pre-moulded forward and rear stubs.
Drill a hole of 0.2 mm diameter through the top of the bracing post on the top edge of the upper fin.

Drill a hole of 0.2 mm diameter through the top of the bracing post on the bottom edge of the lower fin.

Drill a hole of 0.3 mm diameter through the pre-moulded stub at the rear of the upper fin.

Drill a hole of 0.3 mm diameter through the pre-moulded stub at the rear of the lower fin.

Fin bracing wires:

Drill a hole of 0.3 mm diameter through the pre-moulded post bracket at the top of the upper fin.

Drill a hole of 0.3 mm diameter through into the fuselage outer, rear edge, inboard from the tailplane adjustment control levers. The holes should be drilled to align with the pre-drilled holes in the bracket on the upper fin (when fitted).

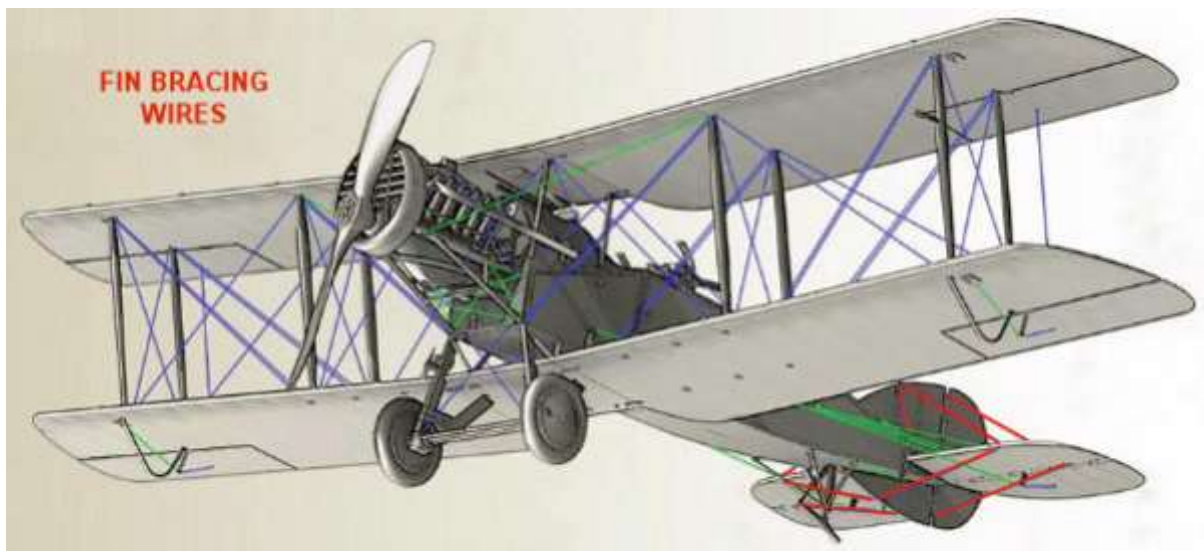
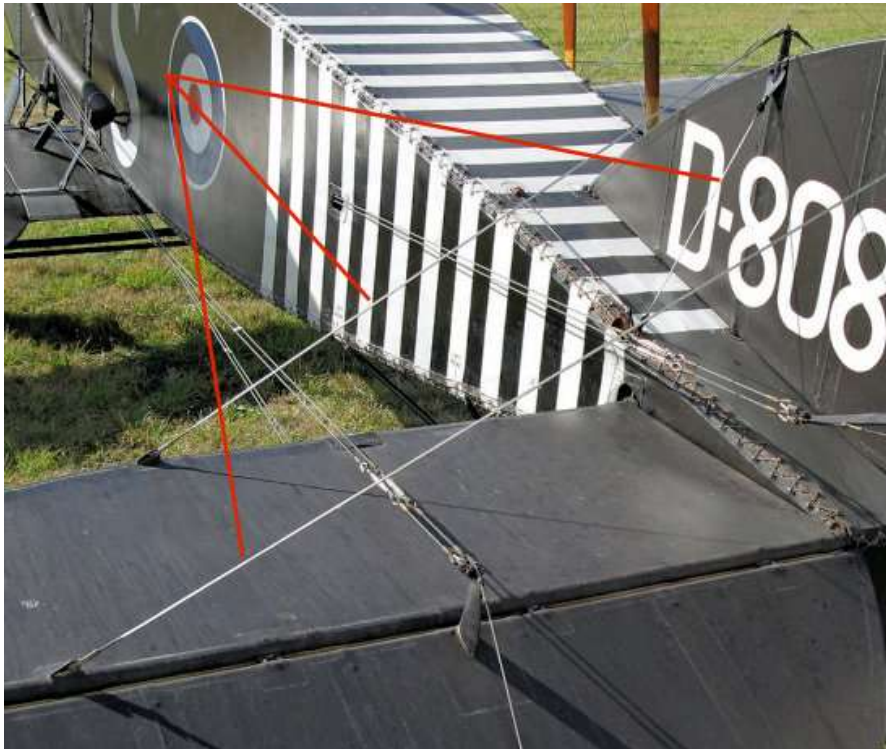

Drag wires:

Drill a hole of 0.3 mm diameter into, **but not through**, the underside of the upper wing, at the pre-moulded recess forward from the inboard of the forward interplane strut location. The hole should be drilled to align with the open air scoops in the engine side panels (when fitted).

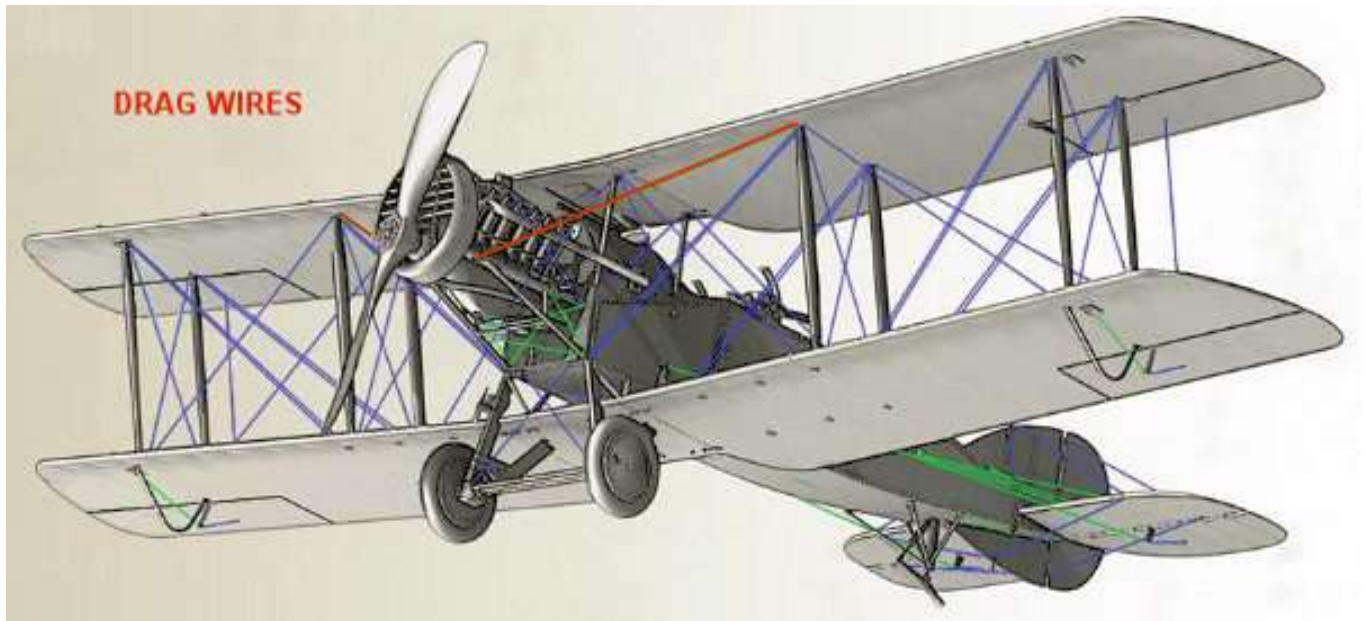

Lower wing bracing wires:

NOTE: *The lower wing bracing wires are diagonally crossed.*

Drill a hole of 0.3 mm diameter **through** the top of the lower wing, inboard from the pre-moulded locating hole for the bottom of the fuselage to wing 'V' support strut.

Drill a hole of 0.3 mm diameter into the underside of the fuselage, inboard from the location for the rear strut of the 'V' struts. The holes should be drilled to align to the pre-drilled strut holes in the lower wing (when fitted).

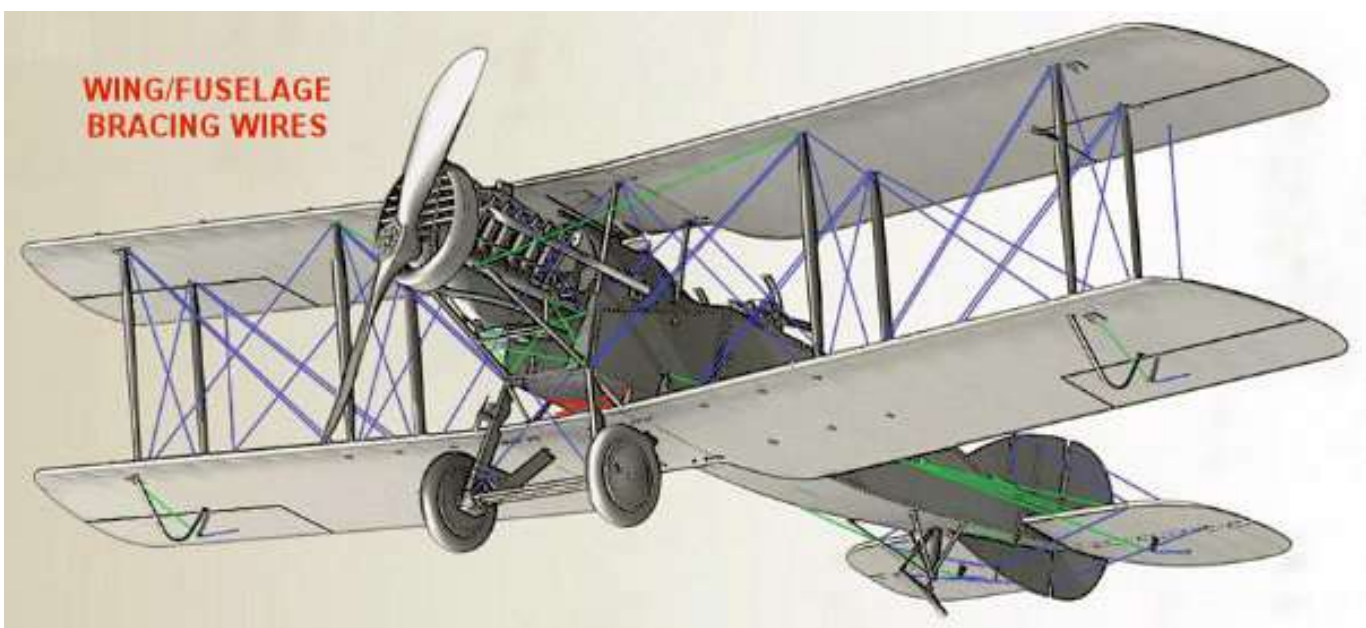

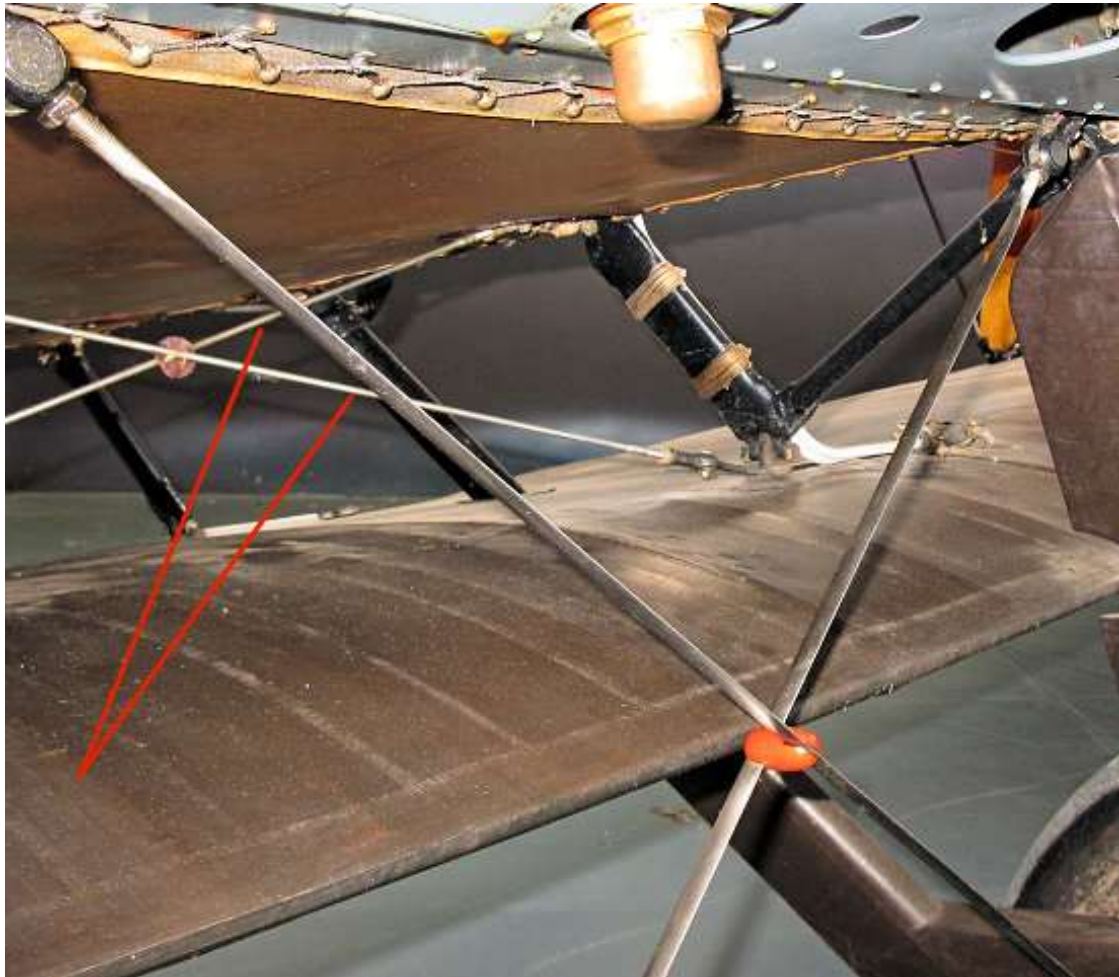

PART 13
CONSTRUCTION
(CONTINUED)

PART 13 - CONSTRUCTION (CONTINUED)

NOTE: *When cementing large kit parts, I use 'Revell' Contacta Professional cement (39604). This is a thicker liquid cement, which takes longer to fully set, but does provide a stronger bond between larger kit parts. 'Tamiya' liquid cement is used for smaller parts.*

Before working with or cementing model parts together, make sure all mould seams, sprue tags, mould 'flash', paint or primer is removed from each part.

Refer to the relevant pages in the kit instruction manual.

My sequence of building this model may not follow the kits instruction manual. This is due to incorporating modifications as I progress through the build.

Assembly:

Make sure the two front locating pegs and rear tang of the tailplane, as well as the peg locating holes in the sides of the fuselage, are clear of any primer, paint or decal.

NOTE: *During the following steps, the tailplane will need to be carefully flexed outwards to allow the front pegs to be able to fit into their locating holes.*

Ease the tailplane into its locating slot in the rear of the fuselage

Flex the sides of the tailplane outwards and ease the tailplane forwards to fully locate the pegs into their fuselage holes and the rear tang fully into its fuselage slot.

Cement the tailplane in position.

Cement the upper fin in position in its locating hole in the top, rear of the fuselage and its rear locating stub into the recess in the tailplane.

Cement the lower fin in position in its locating holes in the underside, rear of the fuselage and its top edge against the bottom edge of the upper fin.

Make sure the pre-moulded recesses in the bottom edges of the fuselage, for locating the rear leg of the tail skid supports (A59, A60), are clear of any primer, paint or decal.

Locate each tail skid support into its recess and mark the position of the front leg of the supports onto the underside edge of the fuselage.

Using the marks as a guide, carefully scrape away the decal and paint to enable the support leg to be fixed to the fuselage.

Locate the tail skid stem into its location hole in the underside of the fuselage.

Lightly cement one of the tail skid supports into its locating recess and to the underside of the fuselage then lean the support inwards to engage its bottom stub into the recess in the bottom of the tail skid main leg.

Cement the bottom of the support onto the tail skid main leg.

Repeat the procedure to cement the other tail skid support to the fuselage and tail skid main leg.

Cement the tail skid stem into its locating hole in the underside of the fuselage.

Temporarily fully locate the two landing gear struts into their locating recesses on the underside of the lower wing.

Fully locate the axle into its openings in the landing gear struts.

Cement the axle into the landing gear struts.

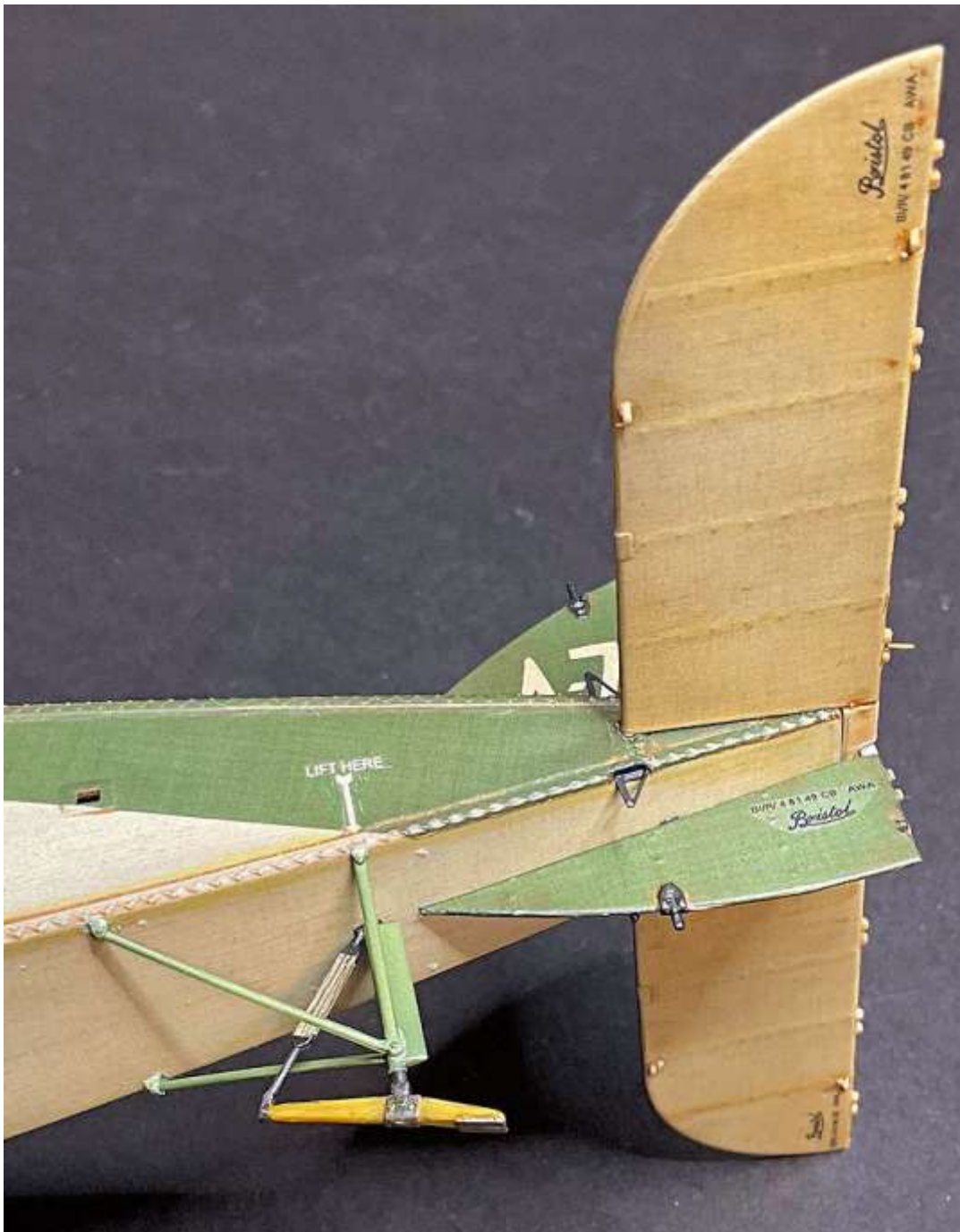

Locate the wheels onto the ends of the axle then clip over the wheel retainers (D17) into their grooves in the axle.

If the wheels are to be fixed on the axle, cement them and the retainers together and to the axle.

Fully locate the outer wheel covers into their recesses in the wheels.

Cement the outer wheel covers into the wheels.

Once the cemented parts are fully set, carefully remove the landing gear assembly from the lower wing.

NOTE: Refer to Part 4 (Weathering) of this build log for more information.

Lightly airbrush a semi-matte clear coat, such as 'Alclad' Light Sheen (ALC-311) or similar, over the wheels. This will provide a good base for applying weathering.

Apply weathering, as desired, to the wheels. I used 'Flory Models' Sand fine clay wash.

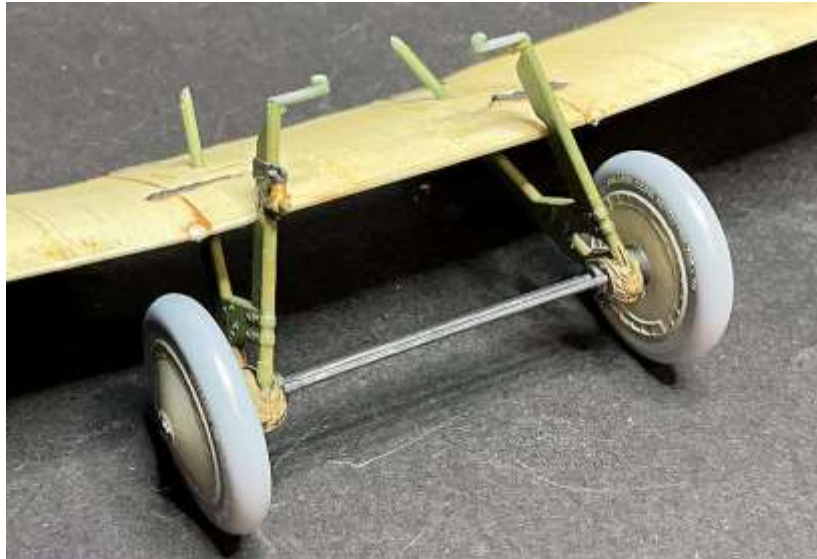

Rigging:

CAUTION: *The following rigging techniques are not easy to carry out. If you are not sure you can do this, I suggest you use the easier method of using 'EZ' stretch line and secure each end of a rigging line into the pre-drilled holes, using the CA adhesive. Secure one end in place then cut the line such that with a little tension, the other end can be secured in position.*

Refer to Part 12 (Preparation for external rigging) of this build log.

Tailplane adjuster cables:

NOTE: *The following procedure applies to all four tailplane adjuster cables. The rigging materials used are:*

'GasPatch' Elite Accessories metal turnbuckles Type C (1:48th scale)

'Steelon' or 'Stroft GTM' Mono-Filament 0.08 mm diameter line

'MFH' 0.4 mm diameter Clear tube (P-957).

Cut a long length of the line.

Cut a short length of the clear tube.

Pass the line through the tube then through an 'eye' end of a turnbuckle.

Loop the line back and through the tube.

Repeat to add a line to the opposite end of the turnbuckle.

NOTE: *The following step is necessary to allow the line to be able to move in the turnbuckle 'eye' end.*

Slide the tubes up to, **but not touching**, the 'eye' ends of the turnbuckle.

Secure the lines in the tubes using thin CA adhesive.

Cut away any residual tag ends of line at the tube end.

Cut a short length of the clear tube.

Pass one line through the tube then through the rigging hole in the top of a fitted photo-etch control lever (P5).

Loop the line back and through the tube, leaving the loop slack in the 'eye' end.
Pass the other line into the pre-drilled hole in the top, side of the fuselage rear.
Position the turnbuckle between the fuselage hole and control lever (see following photograph).
Secure the line in the fuselage using thin CA adhesive.
Pull the line taut at the control lever.
Secure the lines in the tube at the control lever.
Cut away any residual tag ends of line at the tube end.
Brush paint the centre barrel of the turnbuckles with a 50/50% mix of 'Mr. Colour' Brass (219) and Stainless Steel (213) or similar.
Repeat the procedure to add a turnbuckle line for the remaining three tailplane control cables.

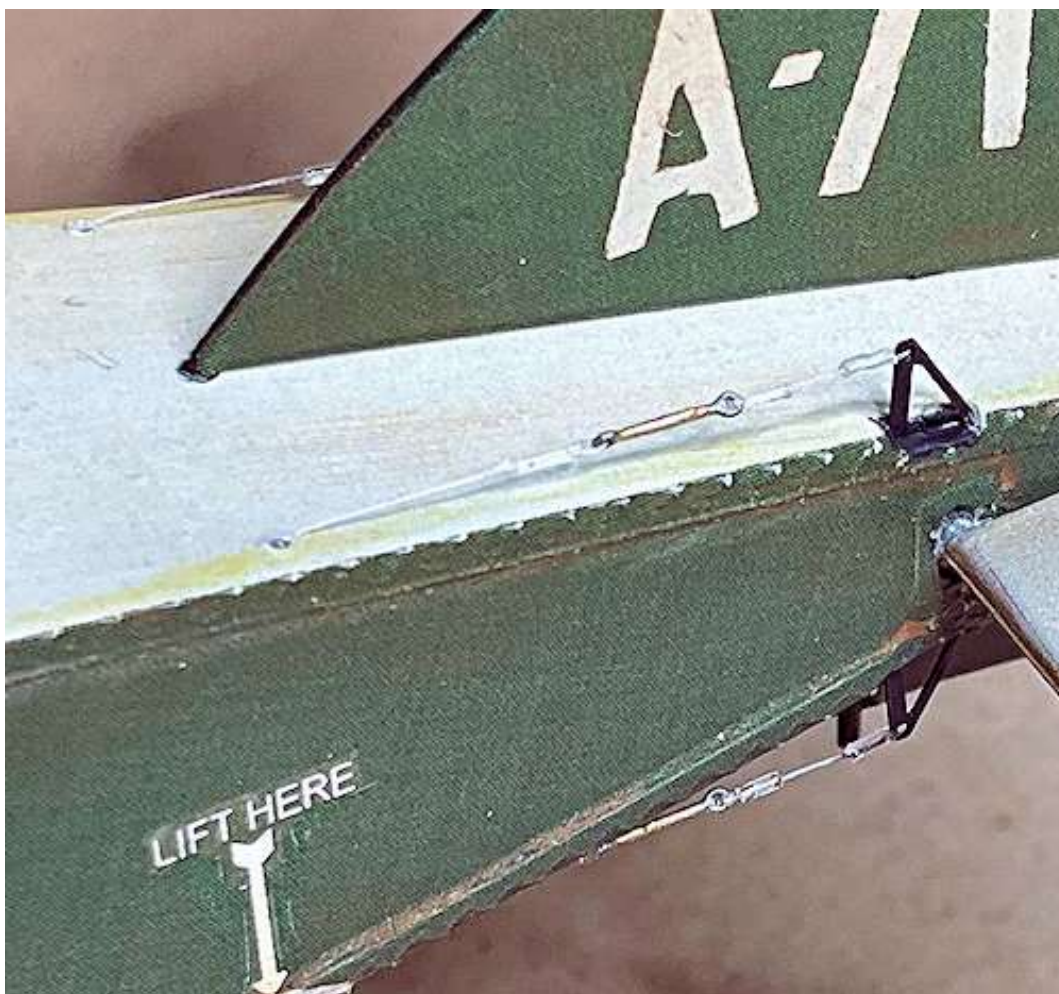

Fin bracing wires:

NOTE: *The rigging materials used are:*

*'Steelon' or 'Stroft GTM' Mono-Filament 0.08 mm diameter line
'MFH' 0.4 mm diameter Clear tube (P-957).*

Cut a long length of the line.

Cut two short lengths of the clear tube.

Pass the line through the two tubes.

Pass one end of the line through the pre-drilled hole in the support bracket at the wire support post on the top of the upper fin.

Pass the other end of the line down into the pre-drilled hole in the top, outer edge of the fuselage inboard from the tailplane adjuster lever.

Secure the line in the fuselage hole using thin CA adhesive.

Pass the line on the other side of the fin through the two tubes.

Pass that end of the line down into the pre-drilled hole in the top, outer edge of the fuselage, inboard from the tailplane adjuster lever.

NOTE: *During the following step, make sure the upper fin is kept vertical on the fuselage.*

Hold the line taut and secure it into the hole using thin CA adhesive.

Slide the tubes against the fuselage and the sides of the fin and secure on the lines using thin CA adhesive.

Forward tailplane bracing wire:

Cut a long length of line.

Cut two short lengths of tube.

Pass the line through the two tubes.

Pass one end of the line down through the pre-drilled hole at the forward stub on the tailplane.

Pass the other end of the line through the pre-drilled hole at the top of the support post on the upper fin.

Cut two short lengths of tube.

Pass the line through the two tubes.

Pass the end of the line down through the pre-drilled hole at the forward stub on the opposite tailplane.

Hold the ends of the line taut and secure the line in the fin support post and tailplane using thin CA adhesive.

Slide the tubes against the fin and the tailplane and secure on the lines using thin CA adhesive.

Cut four short lengths of tube.

Pass the each line through two tubes.

Pass each line through the pre-drilled hole in the top of the support post on the lower fin.

Hold the two ends of line taut and secure them in the fin support post and tailplane using thin CA adhesive.

Slide the tubes against the fin and the tailplane and secure on the lines using thin CA adhesive.

Cut away any residual tag ends of line at the lower fin.

Rear tailplane bracing wire:

Repeat the previous procedure, but with the following differences:

Use the pre-drilled hole through the stub at the top, rear of the upper fin

Use the pre-drilled hole through the stub at the bottom, rear of the lower fin

Use the pre-drilled holes through the rear stubs on the tailplane.



Rudder control cables:

NOTE: *The following procedure applies to all four rudder control cables. The rigging materials used are:*

'GasPatch' Elite Accessories metal turnbuckles Type C (1:48th scale)

'Steelon' or 'Stroft GTM' Mono-Filament 0.08 mm diameter line

'MFH' 0.4 mm diameter Clear tube (P-957).

Cut a long length of line.

Cut a short length of tube.

Pass the line through the tube then through the 'eye' end of a turnbuckle.

Loop the line back and through the tube.

NOTE: *The following step is necessary to allow the line to be able to move in the turnbuckle 'eye' end.*

Slide the tube up to, **but not touching**, the 'eye' end of the turnbuckle.

Secure the lines in the tube using thin CA adhesive.

Cut away any residual tag ends of line at the tube end.

Repeat the procedure to add a turnbuckle to **three additional lines**.

Cut a long length of line.

Cut four short lengths of tube.

Pass the line through a tube then through the free 'eye' end of a turnbuckle on one of the prepared lines.

Loop the line back and through the tube.

Slide the tube up to, **but not touching**, the 'eye' end of the turnbuckle.

Secure the lines in the tube using thin CA adhesive.

Cut away any residual tag ends of line at the tube end.

Pass the free end of the line through another tube then through the pre-drilled hole in the forward end of a the rudder control horn (A6).

Pass the free end of the line through another two tubes then through the free 'eye' end of a turnbuckle on a second prepared line.

Loop the line back and through the tube.

Slide the tube up to, **but not touching**, the 'eye' end of the turnbuckle, positioning the two turnbuckles (see the following photograph).

Secure the lines in the tube using thin CA adhesive.

Cut away any residual tag ends of line at the tube end.

Slide the remaining tubes up to the rudder control horn and secure in position using thin CA adhesive.

Brush paint the centre barrel of the turnbuckles with a 50/50% mix of 'Mr. Colour' Brass (219) and Stainless Steel (213) or similar.

Rudder cable:

NOTE: *The following procedure applies to all four tailplane adjuster cables. The rigging materials used are:*

'Steelon' or 'Stroft GTM' Mono-Filament 0.08 mm diameter line

'MFH' 0.4 mm diameter Clear tube (P-957).

Cut a long length of line.

Cut four short lengths of tube.

Pass the line through a tube then through a pre-drilled hole in the rear end of the rudder control horn.

Loop the line back and through the tube.

NOTE: *The following step is necessary to allow the line to be able to move in the turnbuckle 'eye' end.*

Slide the tube up to, **but not touching**, the rudder control horn.

Secure the lines in the tube using thin CA adhesive.

Cut away any residual tag ends of line at the tube end.

Pass the free end of the line through the another tube then through the pre-drilled hole through the rudder at the pre-moulded stub.

Pass the line through the remaining two tubes then through the pre-drilled hole through the rear end of the rudder control horn on the opposite side.

Slide the tube up to, **but not touching**, the rudder control horn.

Secure the lines in the tube using thin CA adhesive.

Cut away any residual tag ends of line at the tube end.

Slide the remaining tubes up to the rudder and secure in position using thin CA adhesive.



Assembly (continued):

Cement the rudder control horn into its locating slot in the leading edge of the rudder.

Cement the rudder onto the rear of the fins and fuselage.

Rigging (continued):

Rudder control cables:

Pass one of the lower pre-rigged control lines (from the rudder control horn) into the exit port on the fuselage side.

NOTE: *During the following step, do not pull too much on the control line or the rudder may break away from the model.*

Hold the line taut in the exit port and secure it to the bottom of the exit port, using thin CA adhesive.

Repeat the procedure on the other side of the fuselage.

Repeat the procedure on both sides of the fuselage to attach the upper control lines at the top of the exit ports.



Elevator control cables:

NOTE: *The following procedure applies to all eight elevator control cables. The rigging materials used are:*

'GasPatch' Elite Accessories metal turnbuckles Type C (1:48th scale)

'Steelon' or 'Stroft GTM' Mono-Filament 0.08 mm diameter line

'MFH' 0.4 mm diameter Clear tube (P-957).

To attach the twin elevator control lines to the top and bottom of the control horns on both of the elevators, use the following procedure.

Cut a length of line long enough to span the distance between the elevator control horn and the control lever on the side of the fuselage (when fitted).

Cut a short length of tube.

Pass the line through a tube then through an 'eye' end of a turnbuckle.

Loop the line back and through the tube.

NOTE: *The following step is necessary to allow the line to be able to move in the turnbuckle 'eye' end.*

Slide the tube up to, **but not touching**, the 'eye' end of the turnbuckle.

Secure the lines in the tube using thin CA adhesive.

Cut away any residual tag ends of line at the tube end.

Repeat to attach a similar line to a second turnbuckle.

Cut a long length of line.

Cut two short lengths of tube.

Pass the line through the two tubes.

Pass one end of the line through a free 'eye' end on one of the turnbuckles.

Loop the line back and through the tube.

Slide the tube up to, **but not touching**, the 'eye' end of the turnbuckle.

Secure the lines in the tube using thin CA adhesive.

Cut away any residual tag ends of line at the tube end.

Pass the free end of the line through a pre-drilled hole in the end of an elevator control horn (D12).

Cut two short lengths of tube.

Pass the free end of the line through the two tubes.

Pass the free end of the line through the free 'eye' end on the other pre-rigged turnbuckle.

Loop the line back and through the tube.

Slide the tube up to, **but not touching**, the 'eye' end of the turnbuckle.

Position the two turnbuckles to be partly over the tailplane, when the elevator is fitted.

Secure the lines at the turnbuckle in the tube using thin CA adhesive.

Cut away any residual tag ends of line at the tube end.

Slide the remaining two tubes up to, **but not touching**, the control horn, keeping the two lines equal distance from the control horn.

Secure the lines in the tube using thin CA adhesive.



Elevator cables:

NOTE: *The rigging materials used are:*

*'Steelon' or 'Stroft GTM' Mono-Filament 0.08 mm diameter line
'MFH' 0.4 mm diameter Clear tube (P-957).*

To attach the single elevator cables to the top and bottom of the control horns on both of the elevators, use the following procedure.

Cut a length of line long enough the span more than the distance between the elevator top control horn, through the pre-drilled hole in the elevator and to the control horn on the underside of the elevator.

Cut four short lengths of tube.

Pass the line through a tube then loop the line back and through the tube.

Locate the loop of line over the top of the control horn.

NOTE: *The following step is necessary to allow the line to be able to move on the control horn.*

Slide the tube up to, **but not touching**, the control horn.

Secure the lines in the tube using thin CA adhesive.

Pass the free end of the line through another tube then through the pre-drilled hole through the elevator at the pre-moulded stub.

Pass the free end of the line through the remaining two tubes.

Loop the free end of the line back and through the last tube.

Locate the loop of line over the top of the control horn.

Slide the tube up to, **but not touching**, the control horn.

Keeping the line taut, secure the lines in the tube using thin CA adhesive.

Secure the two tubes at the elevators using thin CA adhesive.

Cut away any residual end tags of line at the tube ends.



Attaching the control cables to the control levers:

Cement the elevator control horn fully into its locating slot in the leading edge of the elevator.

NOTE: *During the following step, make sure the rigged lines are kept clear of the tailplane to elevator joints.*

Fully locate the added locating rods of the elevator into their pre-drilled holes in the trailing edge of the tailplane.

Secure the elevator to the tailplane using thin CA adhesive at the rods and cement at the remaining hinges.

NOTE: *The pairs of twin elevator control cables were crossed. On this model the elevators have been fitted at a slight downward angle, so the elevator control levers (D15) were fitted in the fuselage with their tops at a slightly forwards angle and clear of the arc opening for the aileron control cable.*

The elevator upper control lines should be attached to the bottom end of the control levers and the elevator lower control cables to the top end of the levers (cable pairs crossed).

Cement the two elevator control levers (D15), at the required angle, into their locating holes at the lower edge of the fuselage sides (below the pilots cockpit).

Cut two short lengths of tube.

On one side of the fuselage, pass each elevator upper control line through a tube.

Pass the free end of the lines forwards to the control lever.

Pass the free ends of the lines through the pre-drilled hole in the bottom end of the control lever, passing the inner line through from the fuselage side of the lever and the outer line from outboard of the lever.

Keeping both lines taut, secure the to the control lever end, using thin CA adhesive.

Cut away any residual tag ends of line at the control lever.

Slide the tubes up to the control lever and secure in position using thin CA adhesive.

Repeat the procedure to attach the two upper control lines to the other side of the fuselage.

Repeat the procedure on both sides of the fuselage to attach the elevator lower control lines to the top end of the control levers.

Brush paint the centre barrel of the turnbuckles with a 50/50% mix of 'Mr. Colour' Brass (219) and Stainless Steel (213) or similar.



WARNING: The elevator control lines are rigged away from the fuselage and therefore are very exposed. From this point onwards in the build, **take care when handling the rigged fuselage**, to avoid damaging the rigging.



Assembly (continued):

Fully locate the landing gear assembly into the lower wing, with the rear struts through their locating holes in the underside of the lower wing and the cut-outs in the front struts over the wing leading edge.

Cement the rear landing gear struts in the lower wing.

NOTE: During the following step, it's best to offer up the lower wing assembly, so you can check the positioning of the four struts to their locating holes in the lower wing.

Cement the four wing support struts into their locating recesses in the underside edges of the fuselage - left rear (B2), left front (B5), right rear (B1) and right front (B6).

Leave the four struts to set in the fuselage.

Cut two long lengths of 0.12 mm diameter mono-filament, such as that from 'Stroft GTM' or 'Steelon'.

Secure one end of each line into the pre-drilled holes on the underside of the fuselage, inboard from the forward support strut locations (lower wing cross bracing wires).

Temporarily masking tape the two lines clear of the lower wing to fuselage attachment locations.

NOTE: During the following step, take care to not break away any of the four support struts. The fitting of the lower wing to the fuselage is not easy as the two need to locate to four landing gear and six in total support strut locations.

Carefully locate the lower wing to the fuselage and cement the landing gear and support strut locations, making sure the lower wing and fuselage are aligned correctly. The forward support struts should also be cemented to the front landing gear struts.

Leave the cemented assembly to fully set.

Remove the temporary masking tape from the two rigging lines.

WARNING: The assembly of the lower wing to the fuselage is not very sturdy, due to the size and weight of the assembly and fragility of the struts. From this point onwards, care handling on the model is required to avoid the lower wing breaking away from the fuselage.

Cement the lower aileron control horns (D19 x2) for the lower wing into their locating holes in the underside leading edge of the lower ailerons (F11, F12).

Cement the upper aileron control horns (D13 x2) for the upper wing into their locating holes in the top surface leading edge of the upper ailerons (F7, F8).

Rigging (continued):

Lower wing cross bracing:

NOTE: The following rigging uses 'MFH' 0.4 mm diameter Clear tube (P-957).

Cut four short lengths of tube.

Slide the two tubes on one of the pre-rigged bracing wires (under the fuselage) for the lower wing.

Pass the free end of the line diagonally across and through the pre-drilled hole in the lower wing.

Hold the line taut and secure it in the hole in the lower wing, using thin CA adhesive.

Slide the two tubes to both ends of the line and secure in place using thin CA adhesive.

Cut away any residual tag end of line from the underside of the wing.

Repeat the procedure to attach the opposite bracing wire.

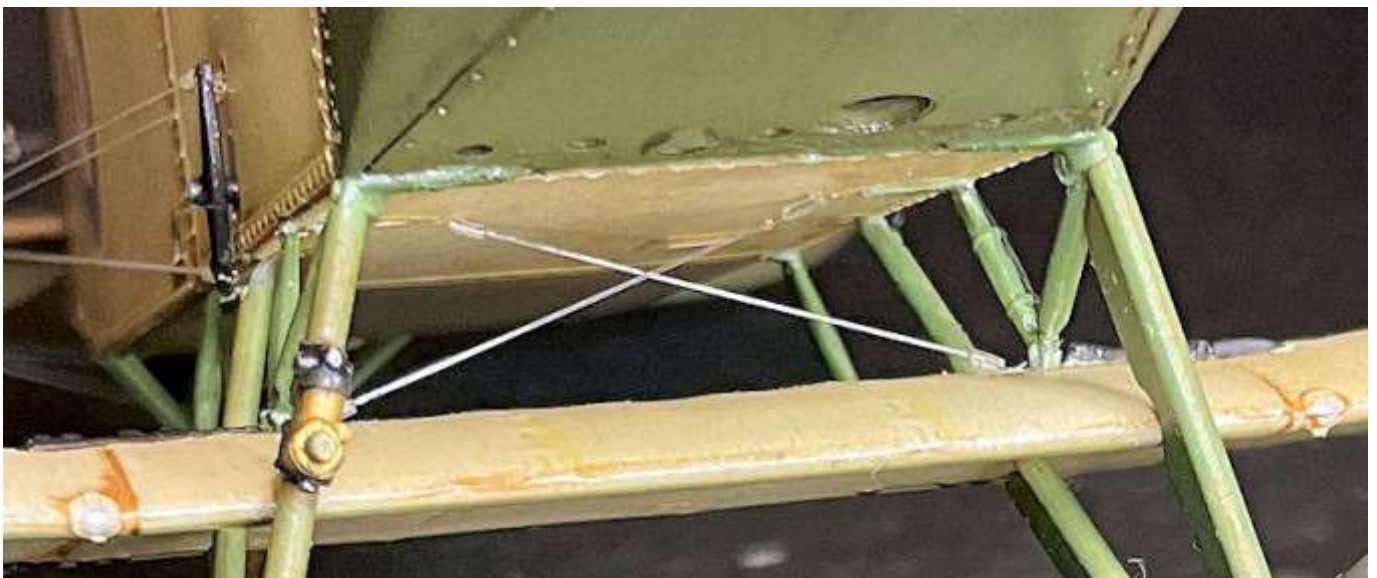

Landing gear cross bracing:

NOTE: *The following rigging materials used are:*

*'Steelon' or 'Stroft GTM' Mono-Filament 0.12 mm diameter line
'MFH' 0.4 mm diameter Clear tube (P-957).*

Cut two long lengths of line.

Cut four short lengths of 'MFH' 0.4 mm diameter Clear tube (P-957).

Slide two tubes on one of the pre-rigged bracing wires.

Pass the free end of the line through the pre-drilled hole at the top of a forward strut of the landing gear.

Pass the line diagonally across and down then through the pre-drilled hole at the bottom of the opposite forward strut of the landing gear.

Secure the line in the top of the landing gear forward strut, using thin CA adhesive.

Hold the other end of the line taut and secure it in the bottom of the opposite landing gear strut, using thin CA adhesive.

Slide the two tubes to both ends of the line and secure in place using thin CA adhesive.

Cut away any residual tag end of line from the outer face of the two struts.

Repeat the procedure to attach the opposite bracing line to the landing gear.

Add a small drop of a PVA adhesive, such as 'Microscale' Micro Kristal Clear or similar, to represent the wire tie where the wires cross.



Assembly (continued):

NOTE: *The 'Rotherham' wind driven pump, used to pressurize the fuel tank, was connected to the tank with a copper pipe.*



Cut a length of 0.275 (or similar) diameter Copper wire.

Anneal (soften with heat) the wire.

Drill a hole of 0.3 mm diameter into, **but not through**, the outer side of the 'Rotherham' pump, located of the forward, right side strut of the landing gear.

Drill a hole of 0.3 mm diameter into the underside of the fuselage, inboard from the top of the forward, right side strut of the landing gear.

Bend one end of the wire into a semi-circle.

Insert that end of the wire into the pre-drilled hole in the pump and secure it in position using thin CA adhesive.

Bend the wire over the top support bracket of the pump then up and into the hole in the fuselage. Trim the length of the wire to achieve this.

Secure the wire into the hole in the fuselage using thin CA adhesive.



Remove the windscreen (C1) from its sprue gate and file or sand away any residual gate tag from the top of the screen.

Mix 'Hataka' black top paint Vert Fonce (C124) with Medium Green (CO19) to a ration of 50/50.

Brush paint the base and screen surround of the windscreen.

Use a PVA adhesive, such as 'Microscale' Micro Kristal Clear or similar, to secure the windscreen onto its locating recess on the top of the fuselage, forward from the pilots cockpit.

Test fit the four fuselage cabane struts into their locating holes in the underside of the upper wing and their recesses in the fuselage. The two rear struts (A47, A48) locate down into recesses between the fuselage and the cockpit side frames. The two front struts (A45, A46) locate into semi-circular recesses between the front of the fuselage and the engine bulkhead.

Cement the four cabane struts fully into their fuselage locations.

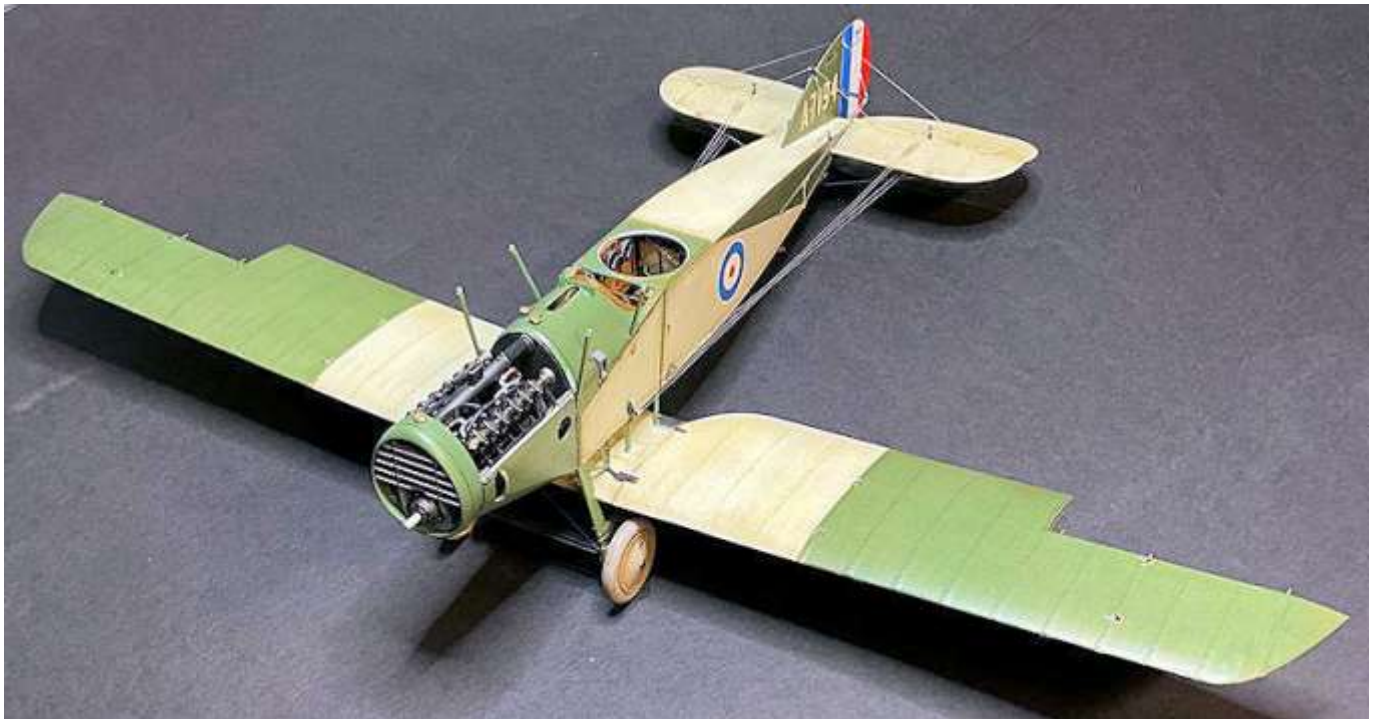

Test fit the outer interplane struts (A43 and D6 x 3) into their location holes in the underside of the upper wing and their recesses in the top surface of the lower wings. Make sure the struts locate fully.

Test fit the inner interplane struts (D7 x 4) into their location holes in the underside of the upper wing and their recesses in the top surface of the lower wings. Make sure the struts locate fully.

Test fit the four fuselage cabane struts into their location holes in the underside of the upper wing. Make sure the struts locate fully.

Fully dry fit the eight interplane struts into their locating recesses in the top surface of the lower wings.

NOTE: *During the following steps, hold the wings together using elastic bands, which helps to keep the struts located.*

Locate the upper wing onto the eight interplane and four fuselage cabane struts, making sure the struts fully locate.

Check that the wings are aligned to each other when viewed from above and the sides.

NOTE: During the following step, apply cement sparingly to the interplane and fuselage cabane struts. This will limit the amount of cement blocking the pre-drilled rigging holes in the wings

Apply cement sparingly to secure the eight interplane and four fuselage cabane struts into their locations in the top surface of the lower wings and underside of the upper wing.

Leave the assembly to allow the applied cement to fully set.



Remove the elastic bands from the wings.

Using a 0.3 mm diameter drill, carefully drill into the pre-drilled rigging locating holes around the interplane and fuselage cabane struts to clear any cement from the holes.

Rigging (continued):

NOTE: The following rigging materials used are:

'Steelon' or 'Stroft GTM' Mono-Filament 0.12 mm diameter line

'GasPatch' Elite Accessories resin British late turnbuckles (1:48th scale).

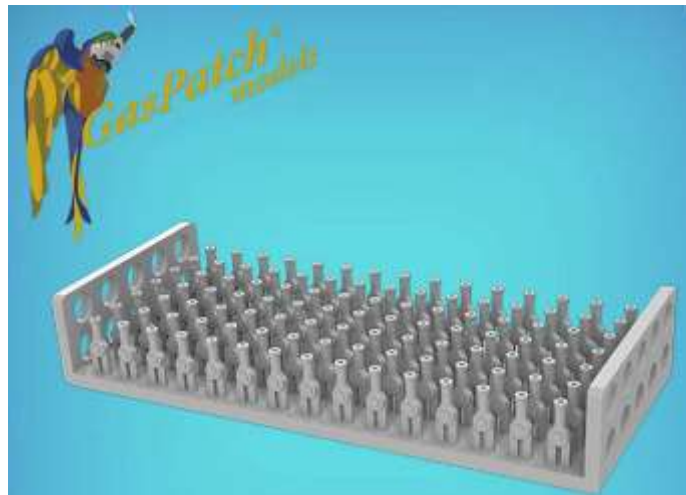

To pre-rig lines for adding all of the flying, landing, incidence, drag and cabane wires, cut forty (40) lengths of line approximately 140 mm long.

Remove eighty (80) 'GasPatch' Elite Accessories resin British late turnbuckles (1:48th scale) from their printing block.

NOTE: The 'legs' of the turnbuckles will prevent the rigged line from aligning correctly. Therefore I chose to remove them.

Use a sharp blade to cut away the two 'legs' of each turnbuckle.

Pass the end of each line through the hole in the end of one turnbuckle, leaving approximately 5 mm protruding from between the 'legs' of the turnbuckle.

Secure each turnbuckle to its line using thin CA adhesive.

Brush paint each turnbuckle on its line with 'Tamiya' Rubber Black (XF85) or similar, making sure to avoid the protruding line at each end.

Brush paint each of the remaining forty (40) turnbuckles with 'Tamiya' Rubber Black (XF85) or similar, making sure to avoid blocking the rigging holes with paint.

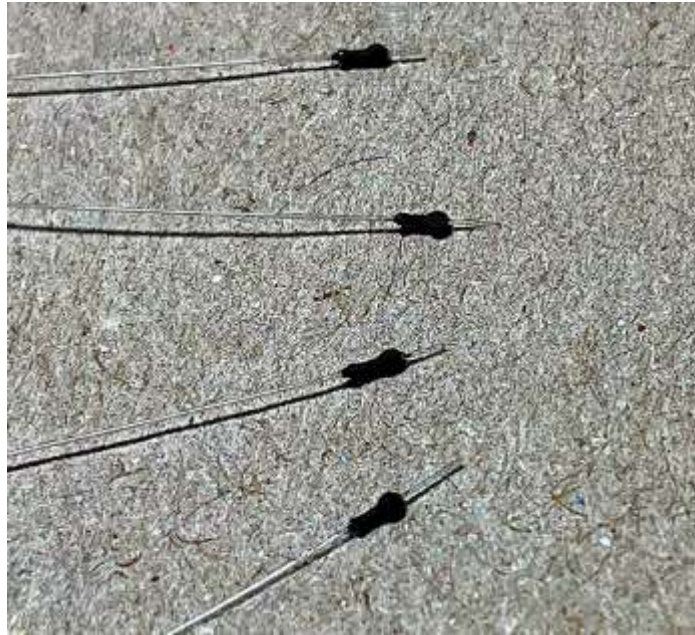

NOTE: During the following rigging steps, the wings can be together using elastic bands, which can help to keep the struts located in the wings. The bands should be moved clear of the rigging areas as rigging proceeds.

The following procedure applies to each of the forty (40) pre-rigged lines.

To keep the model supported and clear of the work surface, lay the aircraft assembly upside down on suitable sized pieces of sponge (under each side of the upper wing and the fuselage).

Test fit the end tag of a pre-rigged line into a pre-drilled rigging hole and if necessary, trim the line so that the line can be fully inserted into the hole with the turnbuckle against the underside of the upper wing.

Secure the end tag of line into its pre-drilled hole.

This procedure should be carried out to attach lines to the following locations:

Eight pairs (16) of flying wires at the interplane struts (underside of upper wing)

Eight (8) single landing wires (underside of upper wing at cabane and inboard interplane struts)

Eight (8) incidence wires (underside of upper wing between interplane struts)

Two (2) drag wires (underside of upper wing at forward inboard interplane struts)

Four (4) cabane strut side bracing wires (between fuselage cabane struts)

Two (2) cabane forward bracing wires (at forward fuselage cabane struts).



Check each line is secure the underside of the upper wing by gently pulling on the line.

Turn the model over and keep the model supported and clear of the work surface by resting the aircraft assembly on suitable sized pieces of sponge (under each side of the lower wing and the fuselage).

Rigging - final tensioning:

Invariably after rigging has been completed, some lines may be slack. This can be remedied by careful application of heat along the line. Any slack line should be tightened before rigging the next line.

WARNING: *Care needs to be taken when using this method to tension line, as using a heat source is required.*

NOTE: *Take care not to linger at one area of a line with the heat source as this will melt the mono-filament causing the line to break. Also take care not to touch any part of the model or any other rigging, as this will also cause damage through melting.*

Carefully move a suitable heat source (I use a small electrical soldering iron) close to and along the slack line, keeping the heat source always moving. You will see the line tension as the applied heat takes effect, shrinking the line.

Rigging (continued):

NOTE: *The following sequence for final rigging the model allows for easier access to the various rigging lines and will better hold the wings together during rigging.*

1. *Fuselage cabane strut side bracing wires*
2. *Fuselage cabane strut forward bracing wires*
3. *Interplane strut bracing wires*
4. *Flying wires*
5. *Drag wires*
6. *Landing wires*
7. *Aileron control cables (fuselage to lower wing).*

1.

Fuselage cabane strut side bracing wires (rear):

Trim the length of the lines such that they can be inserted through the pre-moulded slots in the lower side of the fuselage panel.

Hold the lines taut and secure in the slots using thin CA adhesive.

Fuselage cabane strut side bracing wires (forward):

Pass the free ends of the lines through the barrel of a turnbuckle.

Pass the free ends of the lines through the pre-drilled hole in the fuselage panel, at the bottom of the rear fuselage cabane struts.

From inside the pilots cockpit, pull the lines out of the cockpit.

Hold the lines taut and keeping the turnbuckle clear, secure in the holes using thin CA adhesive.

Slide the turnbuckles down to the struts and secure on the line using thin CA adhesive.

Using a sharp and curved blade, carefully cut away the excess line from inside the cockpit.

2.

Fuselage cabane strut forward bracing wires:

Pass the free ends of the lines diagonally down and behind the engine, to exit through the round opening in the engine lower access panel.

Hold the lines taut and secure against the rear edge of the round opening in the panel.

Cut away the excess line at the edge of the round opening.

3.

Interplane strut bracing wires:

NOTE: *The following procedure applies to all eight (8) of the interplane incidence wires.*

Pass the free ends of the lines through the barrel of a turnbuckle.

Trim the length of the lines such that they can be inserted into the pre-drilled hole in the lower wing, at the bottom of the opposite interplane struts.

Hold the lines taut and keeping the turnbuckle clear, secure in the lower wing holes using thin CA adhesive.

Slide the turnbuckles down to the struts and secure on the line using thin CA adhesive.

4.

Flying wires:

NOTE: *The following procedure applies to all sixteen (16) of the flying wires.*

Pass the free ends of each line through the barrel of a turnbuckle.

Trim the length of the line such that it can be inserted into the associated pre-drilled hole in the lower wing, at the bottom of the diagonally opposite interplane struts.

Hold the line taut and keeping the turnbuckle clear, secure in the lower wing holes using thin CA adhesive.

Slide the turnbuckle down to the strut and secure on the line using thin CA adhesive.

5. Drag wires:

NOTE: *The following procedure applies to both drag wires.*

Trim the length of the lines such that they can be inserted through the cooling intake scoops on the forward, side of the engine access panels.

Hold the lines taut and secure centrally against the forward edge of the cooling intake scoops, using thin CA adhesive.

6. Landing wires:

NOTE: *The following procedure applies to all eight (8) of the single landing wires.*

Pass the free ends of the lines through the barrel of a turnbuckle.

Trim the length of the lines such that they can be inserted into the pre-drilled hole in the lower wing, at the bottom of the opposite interplane struts.

Hold the lines taut and keeping the turnbuckle clear, secure in the lower wing holes using thin CA adhesive.

Slide the turnbuckles down to the struts and secure on the line using thin CA adhesive.

7. Aileron control cables (fuselage to lower wing):

NOTE: *The following procedure applies to the fuselage to lower wing control cables on both sides of the aircraft.*

Cut a long lengths of 0.08 mm diameter mono-filament, such as that from 'Steelon' or 'Stroft GTM'.

Secure one end of the line into the pre-moulded 'arc' slot in the fuselage side (near the elevator control lever), using thin CA adhesive.

Trim the length of the line such that it can be inserted into the pre-drilled hole in the lower wing, inboard from the outer, forward interplane strut.

Hold the line taut and secure it in the lower wing hole using thin CA adhesive.



Assembly (continued):

Ailerons:

Fully locate each of the four ailerons onto their fitted rods in the upper and lower wings.

Secure the ailerons in position using thin CA adhesive.

Rigging (continued):

Aileron interconnecting cables:

NOTE: *The following procedure applies to the two ailerons on both sides of the aircraft. The rigging materials used are:*

'Steelon' or 'Stroft GTM' Mono-Filament 0.08 mm diameter line

'MFH' 0.4 mm diameter Clear tube (P-957).

Cut a long length of the line.

Cut a short length of the tube.

Pass the line through the tube then through the pre-drilled hole in the end of the upper aileron control horn.

Loop the line back through the tube then slide the tube up to, **but not touching**, the control horn.

Position the line facing forwards over the upper wing.

Secure the lines in the tube using thin CA adhesive.

Cut away any residual end tag of line at the tube end.

Trim the free end of the line such that it can be inserted (held taut) into the pre-drilled hole in upper wing, near the access panel.

Hold the line taut and secure the line in the pre-drilled hole using thin CA adhesive.

Repeat the procedure to attach a line to the lower wing aileron.

Cut a length of the line longer than needed to span between the upper and lower wings and their aileron control horns.

Cut a short length of the tube.

Pass the line through the tube then through the pre-drilled hole in the end of the upper wing aileron control horn.

Loop the line back through the tube then slide the tube up to, **but not touching**, the control horn.

Position the line facing rearwards over the aileron.

Secure the lines in the tube using thin CA adhesive.

Cut away any residual end tag of line at the tube end.

Pass the free end of the longer between wing line rearwards and through the pre-drilled hole in the aileron, then between the wings and through the pre-drilled hole in the other aileron.

Cut a short length of the tube.

Pass the line through the tube then through the pre-drilled hole in the end of the lower wing aileron control horn.

Loop the line back through the tube then slide the tube up to, **but not touching**, the rear of the control horn.

Secure the lines in the tube using thin CA adhesive.

Cut away any residual end tag of line at the tube end.

Repeat the procedure to attach aileron control lines to the ailerons on the opposite side of the aircraft.



Assembly (continued):

Filter bowl:

NOTE: A filter bowl was fitted on the bottom of the engine bulkhead and protruded through the underside, rear of the engine lower access panel.



To represent the filter bowl I used a small diameter piece of scrap sprue and painted it with 'Tamiya' Bronze (X33). It was then secured in position, using thin CA adhesive) in the filter bowl opening at the rear edge of the engine underside access panel.



Engine exhaust pipes:

NOTE: *The kit supplied engine exhaust pipes are replaced by those supplied in the 'Proper Plane' Bristol wood propeller and 'REXx' exhaust (PR-036-32015) set.*

CAUTION: *Handle the exhaust pipes with care as they can be easily crushed or distorted.*

Using thin CA adhesive, secure the two REXx exhaust pipes in position against the exhaust ports on the outer sides of the engine.



Wing hoops:

NOTE: *The wing hoops are fitted with the longer 'leg' facing forwards.*

Cement the two wing hoops (D2) into their locating holes in the outer undersides of the lower wing.

Propeller:

Using CA adhesive, secure the propeller onto the engine propeller shaft and in the desired position.



Observers Lewis guns assembly:

NOTE: *The observers Lewis machine guns and mounting were prepared in Part 10 (Weapons) of this build log.*

Using a naked flame, such as that from a cigarette lighter, heat the observers seat belt (P1) until it changes colour. This will anneal (soften) the photo-etch to enable it to be bent to shape more easily.

Bend the main seat belt around a suitable round former to curve the belt such that it will hang naturally when attached to the gun mounting ring.

Airbrush the seat belt with a grey primer, such as 'AK Interactive' Grey (AK758) or similar.

Airbrush the seat belt with 'Tamiya' Buff (XF57) or similar.

Clean away and paint or primer from the pre-moulded seat belt recesses on the inside of the gun mounting ring.

Using thin CA adhesive, secure the ends of the seat belt into their locating recesses in the gun mounting ring.

Cement the mounting for the two Lewis machine guns into its mounting on the gun mounting ring.

Cement the machine gun assembly into its locating hole over the observers cockpit.



PART 14

FIGURES

PART 14 - FIGURES

The figures used for this model are the 'Kellerkind' RFC mechanic middle East (54/107), 'Copper State Models' Aussie Digger (F32-052) and the 'Master Box' Camel and rider from box set (MB3564).

NOTE:

The 'Copper State Models' and the 'Kellerkind' figures are moulded in resin, as opposed to the normal styrene used for the 'Master Box' figure and camel. The properties of resin differ radically to those of plastic kits.

Below I have listed what I have found to be the primary differences for resin parts:

- 1. When resin kits are cast in their moulds, a release agent is applied to enable the cast resin parts to be more easily removed, which is similar to plastic kit moulding. This release agent can leave a film on the surface of the kit parts, which, if not removed, can prevent paint or adhesives from adhering to the surfaces. The easiest way to remove this film is to carefully and fully wash all of the model parts in warm soapy water, using an old, soft tooth brush, then rinse all of the parts thoroughly and leave to dry.*
- 2. Resin, by its nature, is very brittle and can be damaged or broken easily, especially when handling small parts. This is particularly evident when separating the individual items from the resin cast. The best way to remove item is to cut them away with a razor saw, then clean them up afterwards.*
- 3. Once removed from the resin cast, parts can have 'resin flash' around or amongst parts, especially small items. This is easily removed with a sharp scalpel blade. Heavier residue can be scraped, filed or sanded away.*
- 4. Styrene (plastic) models are assembled using solvent adhesives, which melt the surface where it is applied and 'weld' the joint together. Resin however will not react to this type of adhesive and can really only be glued using CA adhesive. This adhesive reacts to moisture in the air and on the surface to be joined. Therefore, it will also bond skin to whatever it touches, if the skin has CA adhesive on it. Obviously, extreme care needs to be exercised when assembling resin kits using CA adhesive.*
- 5. Cutting, sanding and drilling resin will create swarf and more importantly, resin dust. The dust in particular is dangerous, especially if inhaled. Therefore always vacuum the working area, and yourself, regularly. If you have a face mask or filtered respirator and find you can wear it whilst working, then do so. Resin can easily be drilled or scraped, but remember how brittle resin is when it is being handled.*
- 6. It is not unusual to find imperfections in resin cast parts, such as surface blemishes, small 'blow' holes or ragged edges. This can be common on some resin kits. These imperfections can be rectified by sanding/polishing and/or filling with modelling putty, then sanding/polishing.*
- 7. Generally CA adhesive is supplied as 'instant bond' adhesive, but there are some manufacturers, such as 'VMS Fleky', that supply CA adhesive as standard, thin, slow and specific resin adhesive. Whichever adhesive is used you must ensure parts are correctly positioned and aligned before applying the adhesive. Trying to separate mis-aligned parts once the adhesive sets will prove very difficult and may result in irreparable damage to the parts.*

RFC Mechanic:

NOTE: *This figure is supplied as a full body with separate 'coupled' arms.*

Preparation:

Cut away the residual moulding from under the feet of the figure.

Sand and the bottom of the feet and any other residual casting block material.

Cut away the residual moulding from between the coupled arms.

Check the figure for any resin flash or seams. If found, remove by either sanding or scraping.

Check that the coupled arms locate fully into the body and if necessary, adjust the parts to achieve this.

Drill a hole of 0.8mm diameter up into the right leg of the figure, making sure the hole is drilled centrally up into the leg (to avoid the drill breaking through the side of the leg).

Cut a length of 0.8mm diameter Brass rod, such as that from 'Albion Alloy's' or similar.

Using thin CA adhesive, secure the rod into the pre-drilled hole in the leg. This will be used to both hold the figure when it's painted and to mount the figure into the base of the display case.

Assembly:

NOTE: *I found that although the left arm for the figure did locate fully into its location on the body, the right arm did not without applying pressure to hold it in position.*

I secured the left arm fully into its location on the body, using thin CA adhesive.

I then removed some of the resin at the right arm location on the body.

I held the right arm in position against the body then drilled a hole of 0.9 mm diameter through the arm and into the body.

Holding the right arm to one side, a short length of 0.8 mm diameter Brass rod, such as that from 'Albion Alloy's' or similar, was secured into the pre-drilled hole in the body, using thin CA adhesive.

The right arm was then located onto the protruding rod and secured in position, using thin CA adhesive.

Any excess rod protruding from the arm was filed flush to the arm.

Any gaps between the arms and the body were filled with modelling putty, such as 'Deluxe Materials' Perfect Plastic Putty or similar and once set, sanded to blend with the surrounding surfaces.

Painting:

Airbrush the figure with a grey primer, such as 'AK Interactive' Grey (AK758) or similar.

Brush paint the shorts, puttees and 'Pith' helmet with 'Tamiya' Dark Yellow (XF60) mixed with Flat Earth (XF52) to approximately a 70 to 30% ratio.

Brush paint the shirt and band around the 'Pith' helmet with 'Tamiya' Deck Tan (XF55) or similar.

Brush paint the shoes with 'Tamiya' Red Brown (XF64) or similar.

Brush paint the belt and chin strap on the 'Pith' helmet with 'AK Interactive' Brown Leather (AK3031) or similar.

Brush paint the RFC 'Pugaree' on the helmet with 'Tamiya' White (XF2), Medium Blue (XF18) and Red (XF7) or similar.

Brush paint the buttons/Metal fittings with 'Mr. Colour' Stainless Steel (213) or similar.

Brush paint the hair and moustache with 'AK Interactive' British Uniform (AK3081) or similar.

Brush paint the dog tag (on the neck) with 'Tamiya' Hull Red (XF9) or similar.

Brush paint the rag with 'Tamiya' Buff (XF57) or similar.

Flesh:

NOTE: *The following paints for flesh are water based and can be thinned as required using water, which is also used to clean the brushes. It's easier to use a 'wet palette' when applying these paints as this keeps the paint from drying and allows mixing of paints as required. A basic wet palette can be a water proof plastic lid with dampened kitchen roll paper laid inside. The paints are then dripped onto the damp paper and applied from there.*

The paints used for the flesh of the figures are from the 'Citadel' colour range:

Base coat - 'Bugmans Glow'.

Shading - 'Reikland Flesh Shade'.

Flesh tone - 'Cadian Flesh Tone'.

Flesh highlights - 'Kislev Flesh'.

Brush 'Bugmans Glow' over the exposed head and hands of the figure and allow to dry.

Brush thinned 'Reikland Flesh Shade' over the painted head and hands of the figure and allow to dry.

Brush thinned 'Cadian Flesh Tone' over the painted head and hands of the figure and allow to dry. Do not apply the paint such that it completely covers the previous coat, as subtle shadows are necessary around such as the ears, eyes, nose and chin etc.

Brush thinned 'Kislev Flesh' over the painted head and hands of the figure and allow to dry. This application is very light and intended to highlight areas such as the eye brows, ears, bridge of the nose and jaw line etc.

Using a sharp point, apply 'Tamiya' Rubber Black (XF85) or similar to create the eye pupils.

Finish:

Airbrush the figure with a matte (flat) clear coat, such as 'Alclad' Flat (ALC-314) or similar.

Weathering:

Brush a sand coloured pigment, such as 'Flory Models' Light Sand or similar, over the shirt, puttees and shorts.

Sponge 'Tamiya' Weathering Master Set D (Oil Stain) at the pockets in the shorts.

Sponge 'Tamiya' Weathering Master Set A (Sand) over the shoes.



Aussie digger:

NOTE: *This figure is supplied as a full body with a separate head with hat.*

Preparation:

Cut away the residual moulding from under the feet of the figure.

Sand the bottom of the feet and any other residual casting block material.

Check the figure for any resin flash or seams. If found, remove by either sanding or scraping.

Check that the head of the figure locates fully into the body and if necessary, adjust the parts to achieve this.

Drill a hole of 0.8mm diameter up into the right leg of the figure, making sure the hole is drilled centrally up into the leg (to avoid the drill breaking through the side of the leg).

Cut a length of 0.8mm diameter Brass rod, such as that from 'Albion Alloy's' or similar.

Using thin CA adhesive, secure the rod into the pre-drilled holes in the leg. This will be used to both hold the figure when it's painted and to mount the figure into the base of the display case.

Assembly:

Check fit the head in position on the body.

If necessary, carefully remove material from the neck to achieve a full and natural location onto the body.

Using thin CA adhesive, secure the head in position on the body.

Painting:

Airbrush the figure with a grey primer, such as 'AK Interactive' Grey (AK758) or similar.

Brush paint the shorts, puttees and digger hat with 'Tamiya' Dark Yellow (XF60) mixed with Flat Earth (XF52) to approximately a 70 to 30% ratio.

Brush paint the shirt and band around the 'Pith' helmet with 'Tamiya' Deck Tan (XF55) or similar.

Brush paint the shoes with 'Tamiya' Red Brown (XF64) or similar.

Brush paint the braces with 'Tamiya' Buff (XF57) and the leather fittings with 'AK Interactive' Brown Leather (AK3031) or similar.

Flesh:

Brush paint the flesh as for the previous figure.

Brush paint the hair with 'AK Interactive' British Uniform (AK3081) or similar.

Finish:

Airbrush the figure with a matte (flat) clear coat, such as 'Alclad' Flat (ALC-314) or similar.

Weathering:

Brush a sand coloured pigment, such as 'Flory Models' Light Sand or similar, over the shirt, puttees and shorts.

Sponge 'Tamiya' Weathering Master Set D (Oil Stain) at the pockets in the shorts.

Sponge 'Tamiya' Weathering Master Set A (Sand) over the shoes.



Arab rider:

NOTE: *The rider figure is supplied as:*

*Left leg 60
Right leg 59
Left arm 57
Right arm 58
Body 51
Knife 56.*

Preparation:

Remove all of the required parts from the kit supplied sprue gate B.

Remove any residual sprue gate tags from the edges of the parts.

Remove any moulding seam lines from the parts.

Modifications:

Drill a hole of 0.5 mm diameter through the clenched fist of the left hand.

Cut a 25 mm length of 0.5 mm diameter Brass rod, such as that from 'Albion Alloy's' or similar.

Secure the rod into the pre-drilled hole in the left hand, using thin CA adhesive.

Use a pointed, straight blade to hollow out the sleeve on the left arm.

Scrape or sand away the top of the right sleeve at the hand, to reduce in thickness.

Assembly:

Check that the various parts of the figure locate fully together and to each other and if necessary, adjust the parts to achieve this.

Cement the two leg halves (59, 60) together.

Cement the body (51) onto the joined legs.

Cement the left (57) and right (58) arms onto their locations on the body.

Painting:

Airbrush the figure with a grey primer, such as 'AK Interactive' Grey (AK758) or similar.

Brush paint the clothing with 'Tamiya' Grey Green IJN (XF76) mixed with Royal Light Gray (XF80) to approximately a 70 to 30% ratio.

Lightly brush and blend 'Tamiya' RLM Green (XF22) into the creases of the clothing.

Brush paint the head scarf with 'Tamiya' Deck Tan (XF55) or similar.

Brush paint the belt and sash with 'Tamiya' Red (X7) or similar.

Brush paint the hand held cane with 'Tamiya' Dark Yellow (XF60) or similar.



Brush paint the sole of the sandals with 'Tamiya' Desert Yellow (XF59) or similar.

Brush paint the sandal straps with 'AK Interactive' Brown Leather (AK3031) or similar.

Brush paint the dagger and ferrules on the belt sash with 'Mr. Colour' Brass (219) or similar.

Brush paint the exposed blade of the dagger with 'Mr. Colour' Stainless Steel (213) or similar.

Flesh:

Brush paint the face, hands and feet with 'AK Interactive' Base Flesh (AK3011).

Brush thinned 'Reikland Flesh Shade' over the painted head, hands and feet of the figure.

Assembly (continued):

Cement the dagger to the left side of the belt.

Finish:

Airbrush the figure with a matte (flat) clear coat, such as 'Alclad' Flat (ALC-314) or similar.

Refer to Part 4 (Weathering) of this build log - I applied 'Flory Models' Dark Dirt to the head scarf to create a more grimy appearance.



Camel:

NOTE: *The camel figure is supplied as:*

Body halves 46 and 54

Neck and head 45

Tail 47

Ears 55

Saddle blankets 50 and 52

Saddle pommels 48 and 49

Saddle 53.

Preparation:

Remove all of the required parts from the kit supplied sprue gate B.

Remove any residual sprue gate tags from the edges of the parts.

Remove any moulding seam lines from the parts.

Assembly:

Check the joint between the two halves (46, 54) of the camel body for any obvious gaps. If necessary, sand the mating faces flat to achieve a good joint.

Cement the two halves of the camel together, making sure the edges are aligned as best as possible.

Check the joint between the body and neck (45) for any obvious gaps. If necessary, scrape or sand the mating faces flat to achieve a good joint.

Cement the neck into its location on the body, making sure the edges are aligned as best as possible.

Cement the ears (55) into their locating recess on the head.

Preparation (continued):

NOTE: *The rear feet of the camel are moulded at an angle, which does not look natural.*

Carefully sand the undersides of the rear feet of the camel to enable it to stand upright on all four feet.

NOTE: *Due to the thin legs of the camel, holes should be drilled carefully to avoid 'break through' of the drill through the sides of the legs.*

Drill a hole of 0.5mm diameter up into the right rear leg and the front left leg of the camel, making sure the holes are drilled centrally up into the leg.

Cut two lengths of 0.5mm diameter Brass rod, such as that from 'Albion Alloy's' or similar.

Using thin CA adhesive, secure the rods into the pre-drilled holes in the legs. This will be used to both hold the camel when it's painted and to mount the figure into the base of the display case.

Assembly (continued):

Check that the various parts of the camel and it's saddle parts locate fully together and to each other and without any obvious gaps. If necessary, sand or scrape the parts to achieve this.

Cement the saddle (53) centrally onto the top of the pre-moulded blankets on the back of the camel.

Test fit the two saddle blankets (50, 52) against the body sides of the camel and onto the sides of the saddle.

NOTE: *I found that I had to scrape away the pre-moulded blankets from the sides of the camel body as well as thin down the top mating edges of the blankets, in order to achieve a basic fit.*

Cement the two saddle blankets to the body sides of the camel and also against to sides of the saddle.

Scrape or sand across the edges of the bottom of the saddle and tops/ends of the blankets to blend them together.

Cement the tail (47) onto the top, rear of the camel body.

Cement the two pommels (48, 49) into the front and rear locations on the saddle.

Modifications:

NOTE: *The camel has a slightly furry coat and the feet are spayed, allowing the camel to walk on soft sand without its feet sinking into the sand.*

To create the effect of fur on the camel body and to add texture to the tail and the tassels on the blankets, I used a 'Pyrogravure'. This is essentially a small pointed and electrically heated tool, very similar to a soldering iron. The heated tip can be stroked across styrene to soften it and create surface textures.

Use a triangular needle file or similar to separate each of the camels feet to create the two toes typical for camels.



Painting:



Airbrush the camel with a grey primer, such as 'AK Interactive' Grey (AK758) or similar.

Brush paint the camel with a base coat of 'Tamiya' Desert Yellow (XF59) or similar.

Dry brush 'Tamiya' Flat Earth (XF52) across the base coat to add a slightly darker highlight.

Dry brush 'Tamiya' NATO Brown (XF68) on the fur of the neck, shoulders, tail and other desired areas to further darken those areas.

To dull the fur, airbrush the camel with a matte (flat) clear coat, such as 'Alclad' Flat (ALC-314) or similar.



NOTE: *The following are suggested colours only. Paint as desired.*

Brush paint the saddle harness and halter with 'AK Interactive' Brown Leather (AK3031) or similar.

Brush paint the blanket on the camels back with 'Tamiya' Khaki Drab (XF51) or similar.

Brush paint the blanket over the camels hind quarters with 'Tamiya' Dark Sea Grey (XF54) or similar.

Brush paint the saddle under blanket with 'Tamiya' Buff (XF57) or similar.

Brush paint the saddle outer blanket with 'Tamiya' J.A. Green (XF13) or similar.

Brush paint the saddle with 'Tamiya' Desert Yellow (XF59) or similar.

Brush paint the saddle posts with 'Tamiya' Flat Earth (XF52) or similar.

Brush paint the tassels on the bottom edge of the saddle outer blanket with 'Tamiya' Grey Green (XF76) or similar.

Brush paint the leather strips on the sides of the saddle outer blanket with 'AK Interactive' Brown Leather (AK3031) or similar.

Brush paint the tassels on the saddle outer blanket with 'Tamiya' Red (X7) mixed approximately 15% Rubber Black (XF85) to darken.

Brush paint the tassel attachments on the saddle outer blanket with 'Mr. Colour' Brass (219) or similar.

Airbrush the painted surfaces with a matte (flat) clear coat, such as 'Alclad' Flat (ALC-314) or similar.



Decorations:

NOTE: *The camel furniture was often elaborately decorated.*

To add the decorations to the saddle, I used the thinnest stripes from the 'Xtradecal' White parallel stripes (XPX2) decal set. These were cut to 20 mm length and applied across the blanket.

To add the decorations to the saddle harness star, I used the thinnest stripes from the 'Xtradecal' White parallel stripes (XPX2) decal set. The triangles were cut from a scrap lozenge decal from a 'Wingnut Wings' Fokker D.VII kit.

Assembly (continued):

Secure the rider onto the saddle using either cement or CA adhesive.

To represent the harness rope, I cut a long length of 0.375 mm diameter copper wire. This was annealed (softened with heat) then brush painted with 'Tamiya' Dark Yellow (XF60), then dusted with a dark earth pigment, such as that from 'Flory Models' or similar.

A hole of 0.5 mm diameter was drilled into the camels head at the bottom, centre of the head harness. The wire was secured into the hole using thin CA adhesive. The wire was curved down then up to the riders right hand, where it was bent around the hand, cut to length and secured to the hand using thin CA adhesive.



Accessories:

Fuel drum:

NOTE: *The 1:32nd scale fuel drums are cast in resin and available from various online retailers. Also 3D printed oil drums are available.*

Cut the resin casting block from the bottom of the drum then sanded the surface flat.

Drill a hole on 0.9 mm diameter into the centre of the drum bottom.

Cut a length of 0.8 mm diameter brass rod and secured it into the drilled hole in the drum using thin CA adhesive.

Airbrush the drum with a grey primer, such as 'AK Interactive' Grey (AK758) or similar.

Airbrush the drum with 'Alclad' Steel (ALC112) or similar.

NOTE: *Chipping fluids for models or hair spray, when applied, forms a barrier between the base coat and top coat of paint. When water is applied on the top coat, the paint softens and can be scrapped of to create paint scratches or flakes. Only apply **acrylic paint** as the top coat, as lacquer paint dry harder and is more difficult to scratch through.*

Lightly spray the drum with a cheap hair spray or a model chipping fluid.

NOTE: *The actual colour of WW1 fuel drums is uncertain.*

Airbrush the drum with 'Tamiya' RLM Grey (XF22) or similar.

Wet the top coat with water and allow it to soften the top coat of paint.

Using a wood tooth pick or short, stiff brush, carefully scratch through the top coat of paint to create paint scratches or flaked paint.

Airbrush the drum with a matte (flat) clear coat, such as 'Alclad' Flat (ALC-314) or similar.

NOTE: *Refer to Part 4 (Weathering) of this build log for more information.*

Apply weathering, as desired, to the drum. I used 'Flory Models' **Sand** fine clay wash.

Lightly brush 'AK Interactive' Kerosene (AK239) wash around the filler caps to represent fuel stains.

PART 15

DISPLAY BASE

PART 15 - DISPLAY BASE

The display case is made from piano black and clear acrylic sheet of 3mm thickness. The base shoulder, for locating the clear cover, is a second thickness on top of the base plate. This case was purpose built by Paul Moss, who has a retail outlet on Ebay - www.inperspective.com.

For this display I chose to use the 'Javis' Desert Zone Battle landscape (BZ3M) sheet.

The self-adhesive backed information plaque was custom made by the online 'Custom Engraving Shop'.

Preparation:

NOTE: As the 'Javis' sheet is paper backed and not very thick, I decided to fix it onto an A3 foam board 5mm thick.

Cut the required shape from the 'Javis' Desert' sheet.

Trace the outline of the cut sheet onto the foam board.

NOTE: Use test pieces to make sure the adhesive used will fully adhere the 'Javis' sheet to the foam board and that the foam board does not react with the adhesive. Some contact adhesives can melt into the foam board.

Secure the cut 'Javis' sheet onto the foam board, using a suitable adhesive.

Add even weight, such as a heavy book, over the 'Javis' sheet to ensure it is fully in contact with the adhesive and foam board.

Leave the adhesive to fully dry and set.

Remove the weight.

Use a sharp blade to cut the foam board from around the 'Javis' sheet.

Colour the exposed edge of the foam board with a black felt tip pen, such as a 'Sharpie' Black permanent marker (W10) or similar.

Display - assembly:

Place the display sheet onto a sheet of paper and trace its outline onto the paper.

Cut out and discard the shape of the display sheet from the paper.

NOTE: During this stage, make sure that when the model is positioned on the display sheet and on the display case, the model will clear the display cover when placed onto the base.

Place the paper template onto the display base in the required position for the model display.

Using a soft marker, trace the outline of the display sheet outline onto the display base.

Remove the paper template and scuff inside the display sheet outline using a coarse grit sand paper, in order to give a key for the adhesive.

Blow away any residual acrylic dust from the display base.

NOTE: During the next step, do not apply too much adhesive, otherwise when pressure is applied over the mat, excess adhesive may be pressed out from the edges of the mat, spoiling the finish at the mat edges. Test the adhesive used to make sure the foam board does not react with the adhesive. Some contact adhesives can melt into the foam board.

Apply a suitable adhesive inside the prepared area on the display base and if necessary, on the underside of the display sheet.

Position the display sheet onto the adhesive area on the display base.

Add even weight over the display sheet to ensure it is fully in contact with the adhesive on the display base.

Leave the adhesive to fully dry and set.

Remove the weights.

Model positioning:

Place the aircraft model in its final position on the display sheet.

Position the figures and fuel drum in the desired locations on the display sheet and mark the location of their support rods onto the display sheet.

Using the rod marks as guides, drill 0.8 mm diameter holes through the mat and into, **but not through**, the display base.

Snip the rods in the figures and fuel drum to the required length for inserting into the display sheet.

Secure the figures and fuel drum into the pre-drilled holes in the display base, using a suitable adhesive applied to the support rods.

Secure the step ladder onto the display base, using a suitable adhesive.

To prevent damage, remove the model of the aircraft.

Information plaque:

A matching acrylic piano black plaque stand was positioned to the left, front corner of the display base (just in from the edges of the shoulder for locating the transparent acrylic cover).

The area on the underside of the stand and its contact area on the display base were scuffed using a coarse grit sand paper, in order to give a key for the adhesive.

A thin coat of contact adhesive was then applied to both scuffed areas and once the adhesive started to set, the stand was carefully position onto the display base and pressed down to make full contact.

The self-adhesive backed information plaque was the positioned onto the stand and pressed to make full contact.

NOTE: *The aircraft model is not secured to the display base as this can cause shock damage to the model if the display is transported to shows etc. For that the aircraft model would be packed separately for transporting.*

PART 16
COMPLETED
MODEL
PHOTOGRAPHS

PART 16 - COMPLETED MODEL PHOTOGRAPHS

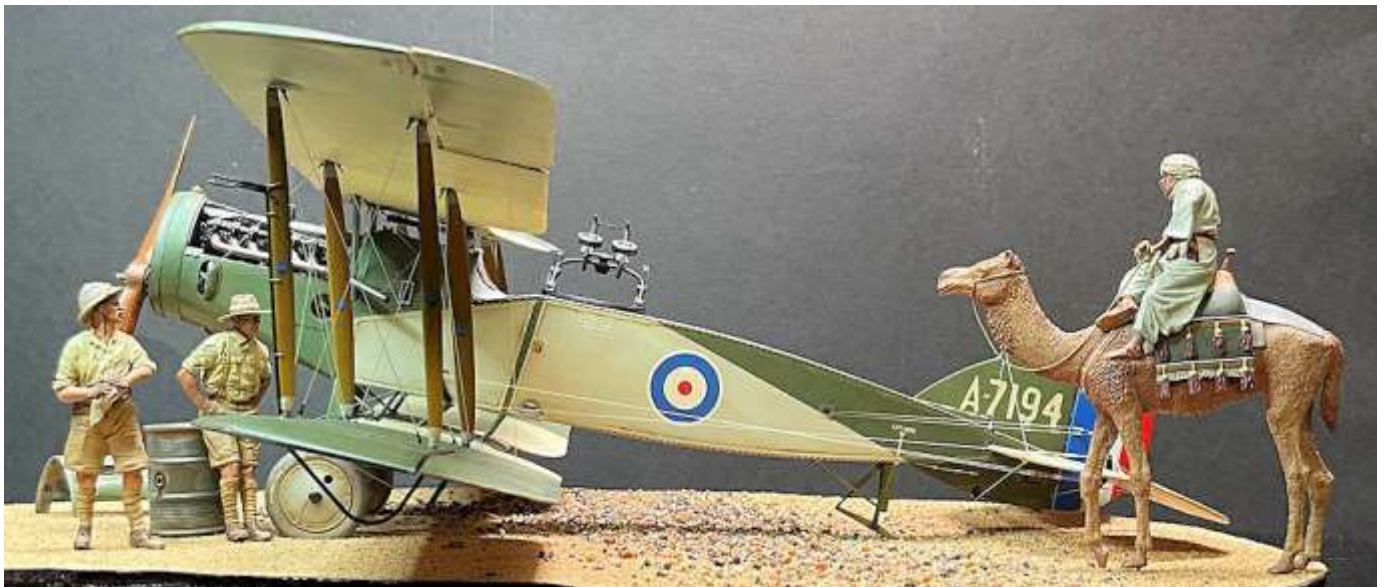
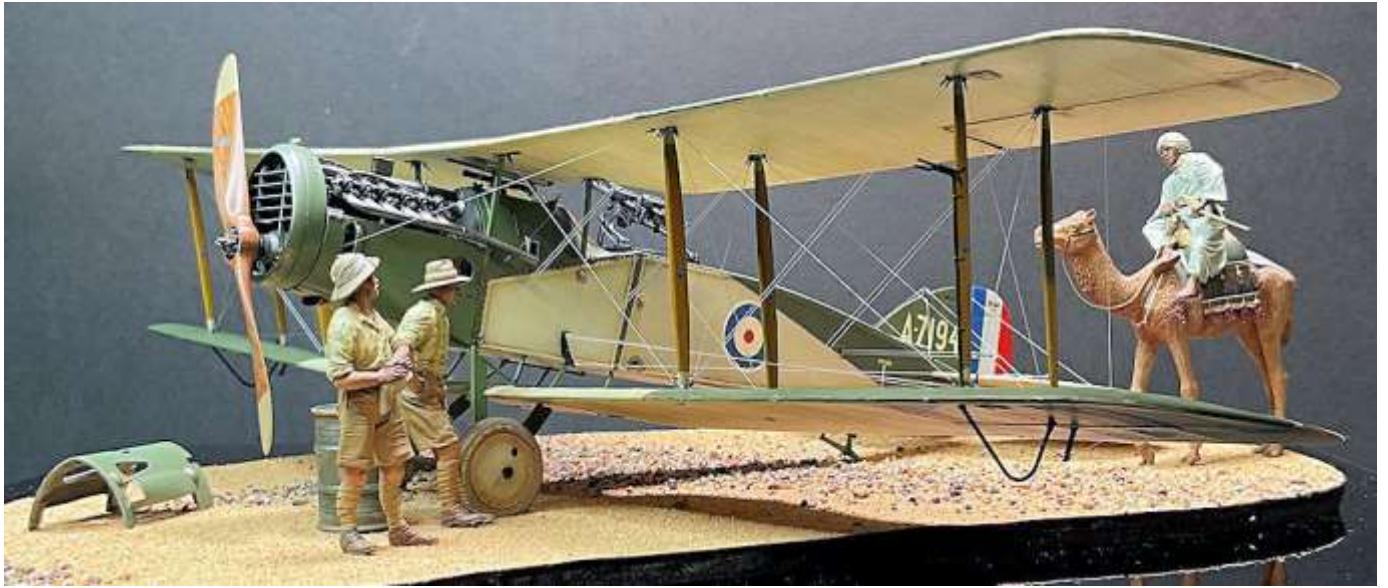

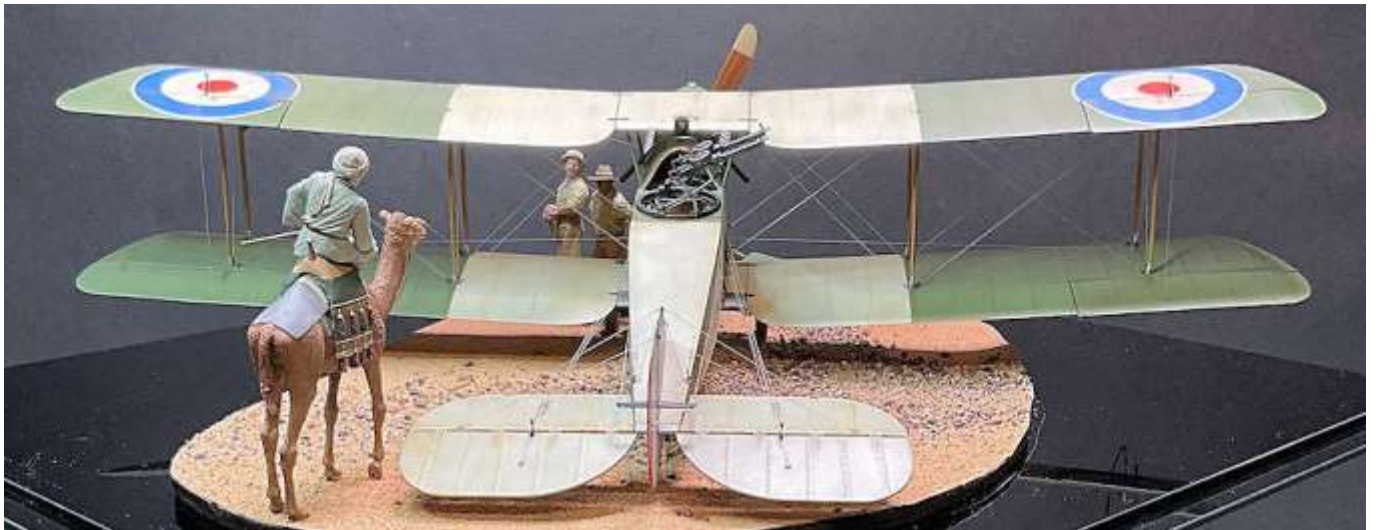

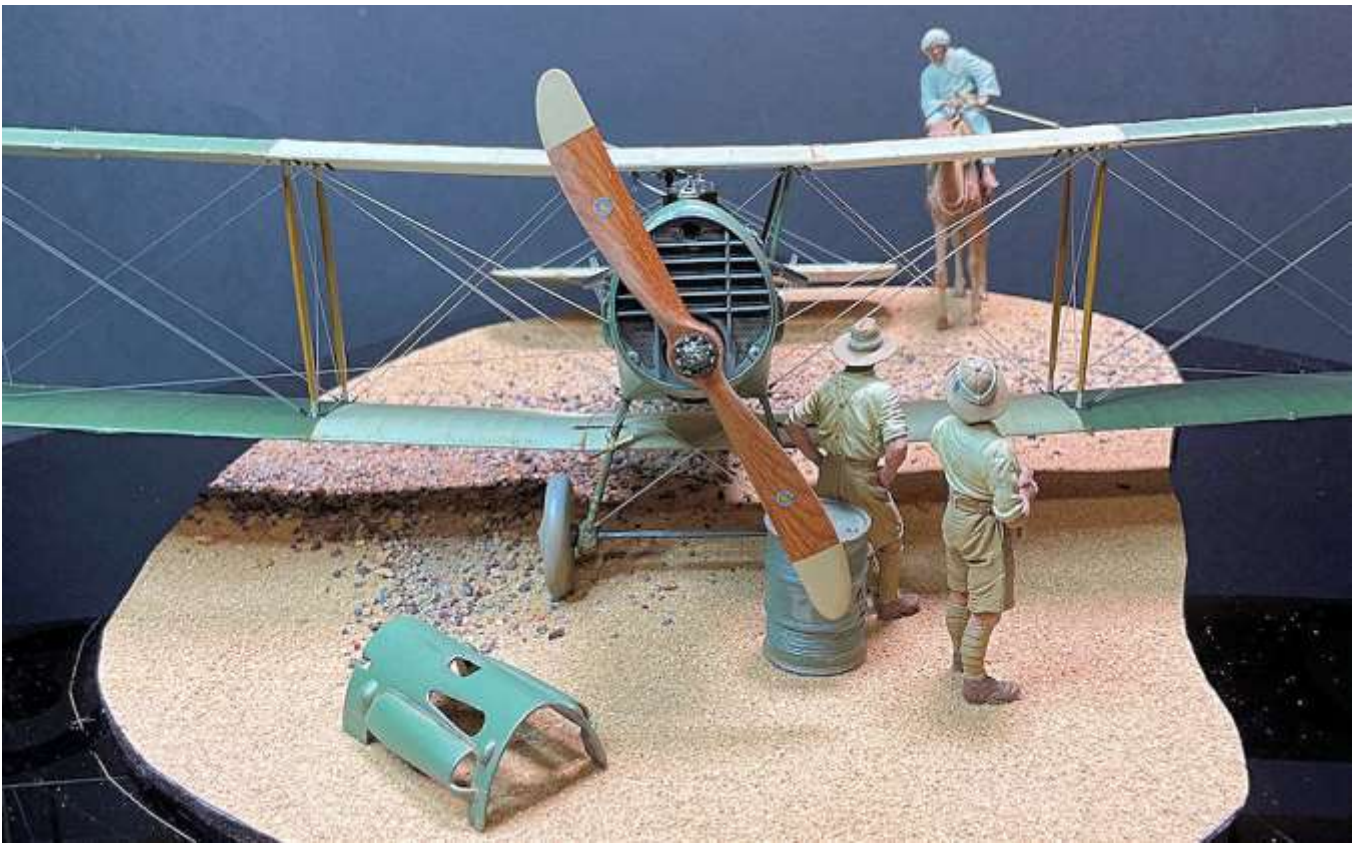
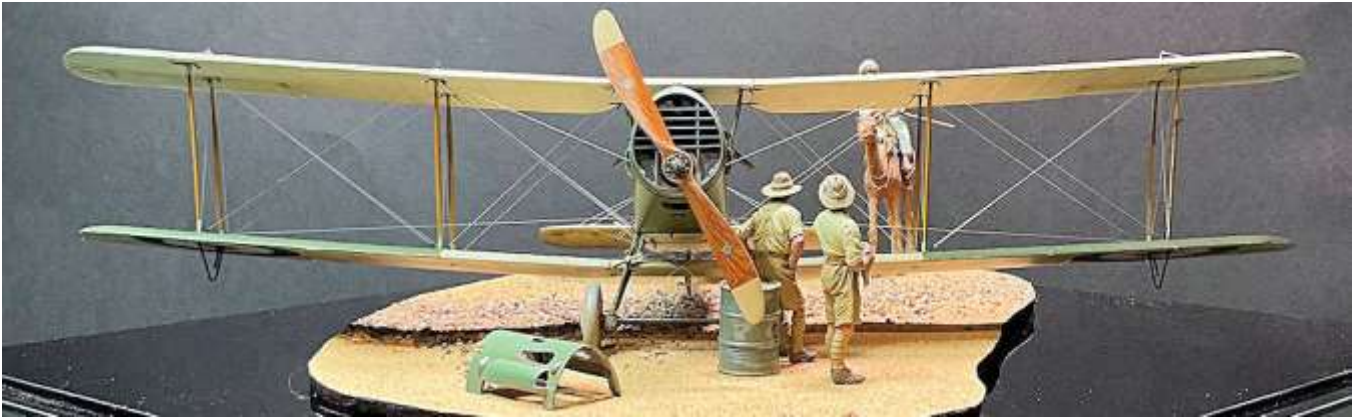



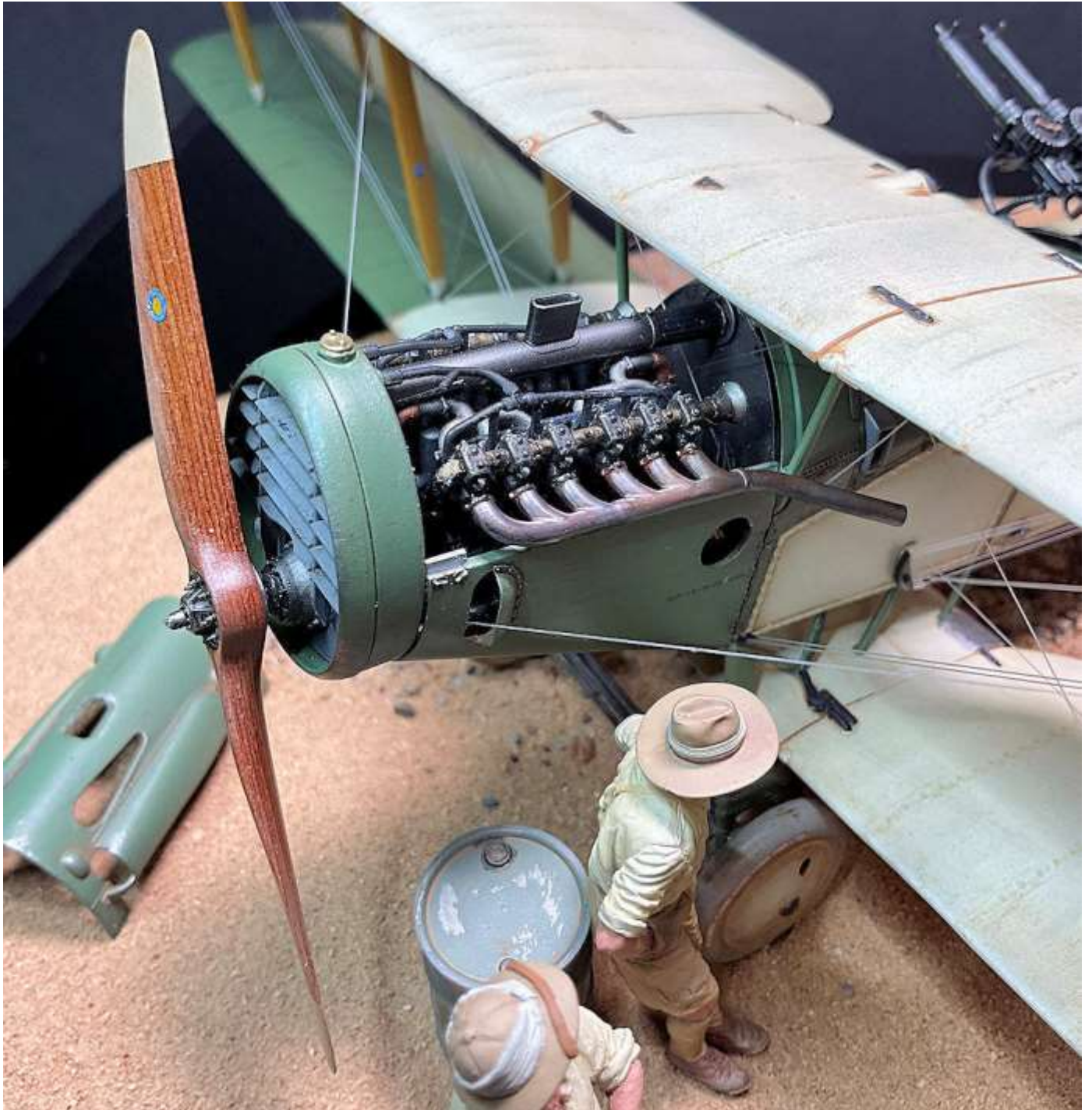







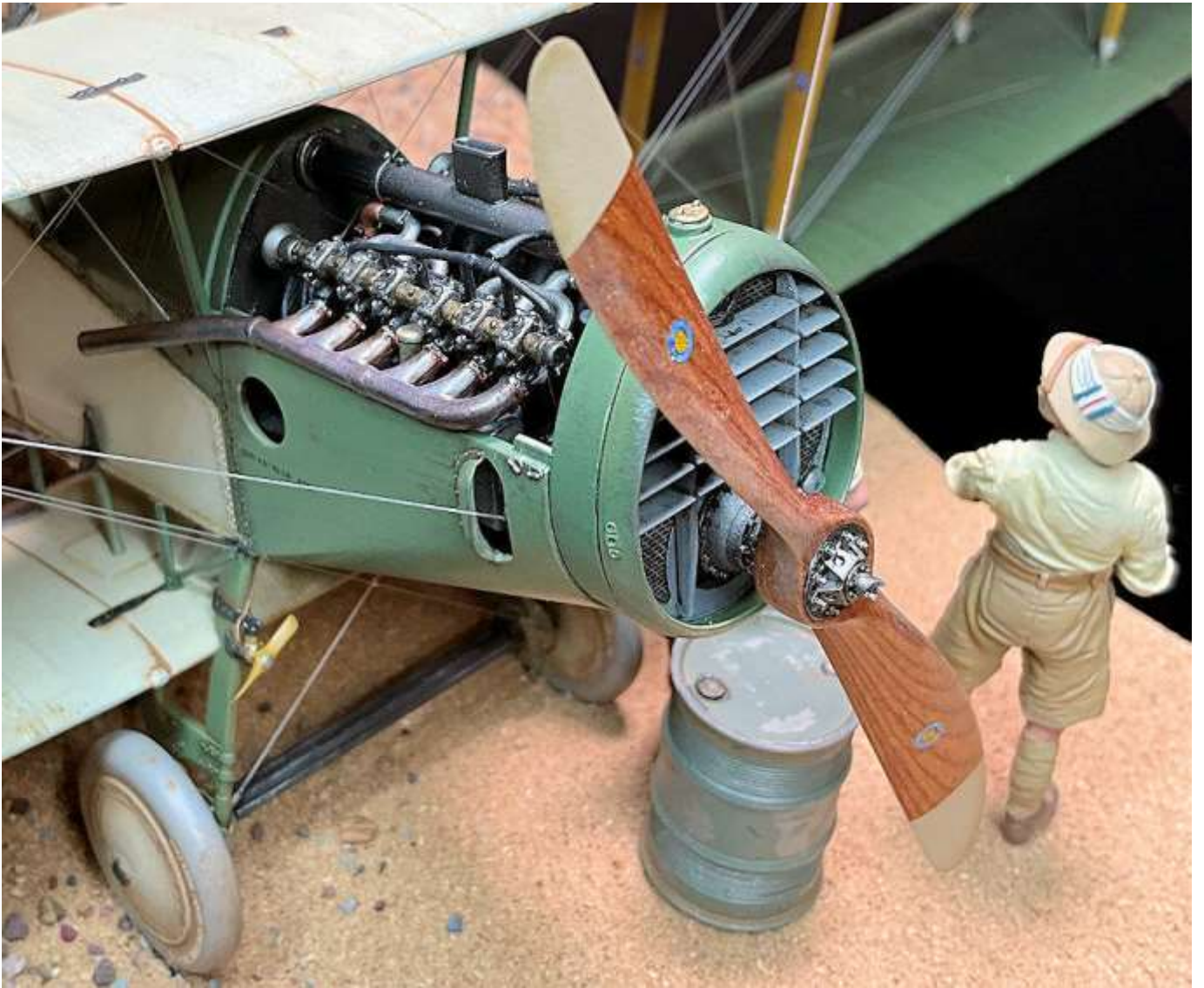



END