



World War One Aircraft Models

I have always held a fascination with early military aircraft. After serving for 27 years in the Royal Air Force, I became a Military Aerospace Technical Author. Although, as most modelers, I got involved in the world of construction kits at an early age, I stopped for most of my service career and for some years afterwards.

I started modeling again a few years ago and now enjoy the challenge of building aircraft of World War One. Since posting photographs of my completed models online, several people have asked if I would create a 'build log' for future builds.

I don't consider myself a 'master' of this craft, but hope to be able to pass on what I have learned. As such, here is my build log, which covers the 1:32 scale resin model of the Ansaldo 'Baby' by 'Lukgraph'.

Mike 'Sandbagger' Norris

sandbaggeruk@sky.com

Completed: October 2020

CONTENTS

INTRODUCTION

AFTER MARKET

THE AIRCRAFT

THIS MODEL.

PART 1 - MODEL DESCRIPTION

PART 2 - WOOD EFFECTS (General)

PART 3 - WEATHERING (General)

PART 4 - DECALS (General)

PART 5 - RESIN (General)

PART 6 - RIGGING (General)

PART 7 - ENGINE

PART 8 - WEAPONS (Information only)

PART 9 - PROPELLER

PART 10 - GROUND EQUIPMENT

PART 11 - PREPARATION

PART 12 - FUSELAGE

PART 13 - CONSTRUCTION

PART 14 - FIGURE

PART 15 - DISPLAY BASE

PART 16 - COMPLETED MODEL PHOTOS

INTRODUCTION

Before I start with the build log, I'd like to show how I've set up my work area. I prefer to keep the work area as clear as I can (I've lost too many small items in the past). I think it's important to have the tools etc you need ready to hand and other, non-essential stuff tucked out of the way until needed. I'm lucky in that I have my 'man cave', which is sorted into a modelling area, airbrush spray booth in addition to my work station PC, games PC and games console.

Sorted



AFTER MARKET

AFTER MARKET

Figures

'Kellerkind' Gotha bomber pilot (54095).

Decals

'Aviatic' Linen/canvas effect (clear decal ATT32236).

Photo-Etch (PE)

'Eduard' WW1 Stitching (EDP32228),
'Aviatic' WW1 short spaced rib stitching (ATTETCH 001),
'PART' 1/48th scale WWI Aircraft Control Horns (S48-087).

Seat belts

'Wingnut Wings' Sopwith F.1 Camel photo-etch belts.

Propeller

'ProperPlane' hand made wood laminate propeller.

Rigging accessories (as required)

'GasPatch Elite Accessories' Turnbuckles 1/48 scale,
'Albion Alloy's' Micro-tube (Brass or Nickel Silver - various diameters).
'Steelon' Mono-Filament 0.12 mm diameter,
'Stroft' Mono-filament 0.08 mm diameter.

Sundries (as required)

'Araldite' two part epoxy adhesive, Paints ('Tamiya' Acrylic, Humbrol Acrylic, 'Mr. Metal Colour', 'AK Interactive' Primer and micro-filler (Grey AK758, White AK759), 'AK Interactive' Filters (Wood AK-261), figure paints and filters (Kerosene AK-2039, Oil AK-2019 and Wash AK-2033), 'Alclad II' Lacquers, 'Alclad' Aqua Gloss 600, 'Mr. Colour' Levelling Thinners, 'Vallejo' Model Colour, PVA Adhesive (e.g. 'MicroScale' Micro Krystal Clear), 'VMS Fleky' Resin CA adhesive (Standard and Thin), 'Bostik' Blue Tack or 'UHU' White Tack, 'AV' Masilla Plastica (401) putty, 'De-Lux Materials' Perfect Plastic Putty, Sanding and/or Polishing sticks from 'Flory Models', 'Humbrol' Maskol, 'Milliput' two part putty, 'White Spirits', 'MicroScale' MicroSol/MicroSet, 'Mr. Surfacer 500, 1000,1200', 'DecoArt Crafters Acrylic' (water based) paints, 'Artool' Ultra Mask sheets, 'Vallejo' Still Water (26.230), 'VMS' Metal Prep 4K, 'Mr. Surfacer' primer and filler, 'Hataka' lacquer paints, 'Plastruct' styrene rod, 'PlusModel' lead wire, 'ANYZ' black braided line (AN001), 'Tamiya' extra thin liquid cement, 'Plastic Magic' liquid cement, 'Prismacolor' Verithin Argent Metallique 753.

Weathering mediums (as required)

'Flory' Clay washes, Flory Pigments, AK Interactive engine washes,
'Tamiya' Weathering Master (Set C, D and E), 'Derwent' Inktense 24 ink pencils.

Display Base

Etched Plaque (name plate),
'Inperspective' custom made Acrylic base and cover,
'Coastal Kits' 1:32 Scale 'Abandoned Airfield' display mat.

THE AIRCRAFT

THE AIRCRAFT

References:

1. Windsock Mini Date file No.15 - Ansaldo Baby (by Gregory Alegi).
2. Windsock Date file No.60 - Sopwith Baby (by J.M Bruce).

The aircraft:

The origins of the aircraft started with two-seat aircraft, which was designed and built by the 'Sopwith Aviation Co.' during November, 1913. Such was its performance that during December 1913 and March 1914, a total of twelve single seat versions were ordered for the Royal Flying Corps (RFC). The aircraft was officially called the Sopwith 'Scout', but became known more by its unofficial name of the Sopwith 'Tabloid'. The Sopwith Aviation Co. decided to enter a modified version of the aircraft for the 1914 Schneider Trophy contest and in April 1914 at Monaco, the aircraft beat all other entrants to win that year's contest. It was after this, in January 1915, that the Royal Naval Air Service (RNAS) placed an initial order for twelve aircraft, to be modified from the land version to one that could be operated as a sea plane. Eventually the RNAS would order a total of 286 aircraft. The first naval version was delivered in February 1915. As the Sopwith Aviation Co. were heavily involved in building the Sopwith 1 1/2 'Strutters' for the RFC, they built 100 aircraft, the rest being sub-contracted to the Blackburn, Fairey and Parnall companies. Overall the aircraft was used not only by Great Britain, but also Canada, United States, France, Chile, Greece, Norway with individual aircraft to Japan and Russia. The aircraft was also built, under license, by the SA Aeronautica Gio Ansaldo of Turin. The Italian aircraft were produced using two Sopwith provided aircraft (Ser No: 8214 and 8215) as specimens, both powered by Gnome Monosoupape 100 hp rotary engines. However the Italian versions were fitted with the Le Rhône 9J rotary engine (120hp) with a circular engine cowl, which needed to have cooling openings cut into the cowl to prevent overheating of the engine. Production was late as the Italian's favoured production of their own naval aircraft types, such as the Macchi designs. A total of approximately 100 aircraft were produced by 1918, but by this time the performance of the 'Baby' was inferior to those aircraft already in use. Therefore most were used for training purposes, although some were used in limited operational coastal defence.

General specifications:

Length - 23 ft (7.01 m)
Wingspan - 25 ft 8 in (7.82 m)
Height - 10 ft (3.05 m)
Wing area - 240 ft² (22.3 m²)
Empty weight - 1,226 lb (557 kg)
Loaded weight - 1,715 lb (779 kg)
Engine - Le Rhône 9J rotary engine (120hp, 89.5 kW)

Performance:

Maximum speed - 87 knots (100 mph, 162 km/h) at sea level
Service ceiling - 10,000 ft (3,050 m)
Rate of climb - 285 ft/min (1.45 m/s)
Endurance - 2.25 hrs

Aircraft colour schemes:

The 'Lukgraph' colour illustrations for this aircraft show the wings covered in linen with the standard Italian tri-colour red and green outer panels, the rest being Clear Doped Linen (CDL). The colour of CDL was effectively raw linen, then doped, which would have weathered in and change the colour eventually.

Underwing of Ser No:16552, held for restoration in Trento's Caproni Museum



Also, the width of the red and green areas were not standard and differed between some aircraft. Some had the colours aligned to the wings ailerons (four wing ribs wide), whereas others were further inboard covering five or six wing ribs. In addition, the red and green colours applied to the underside of the wings would have shown through the CDL top surface as a 'ghost' area. This was evident, even on aircraft that had the upper surfaces of the lower wings painted olive green. As usual the actual colours of WW1 aircraft are difficult to research. The 'Windsock' Mini Date file No.15 - Ansaldo Baby (by Gregory Alegi) indicates the probable Federal Standard (FS) colours. With assistance from Roberto Andervill, who has been involved in the restoration of Italian WW1 aircraft, I chose to use the following colours for this model:

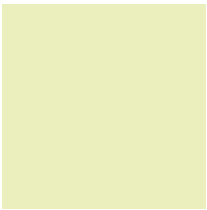

CDL - FS 27855



Red - FS 31302



Green - FS 34090

The inner ring of the National roundels were painted white. However, a feature of Ansaldo built aircraft was not to paint the central band of the rudder marking white, but to leave it as CDL. The difference can be seen on the following photograph of So.5005.



The data file also has an illustration showing the colours applied to the various areas and states that although not always followed, an official order required the upper surface of the lower wing to be coloured an 'olive' green. This was an accepted method of reducing the sunlight glare from the shiny doped surfaces affecting the pilot's vision and was carried out on many Italian aircraft.

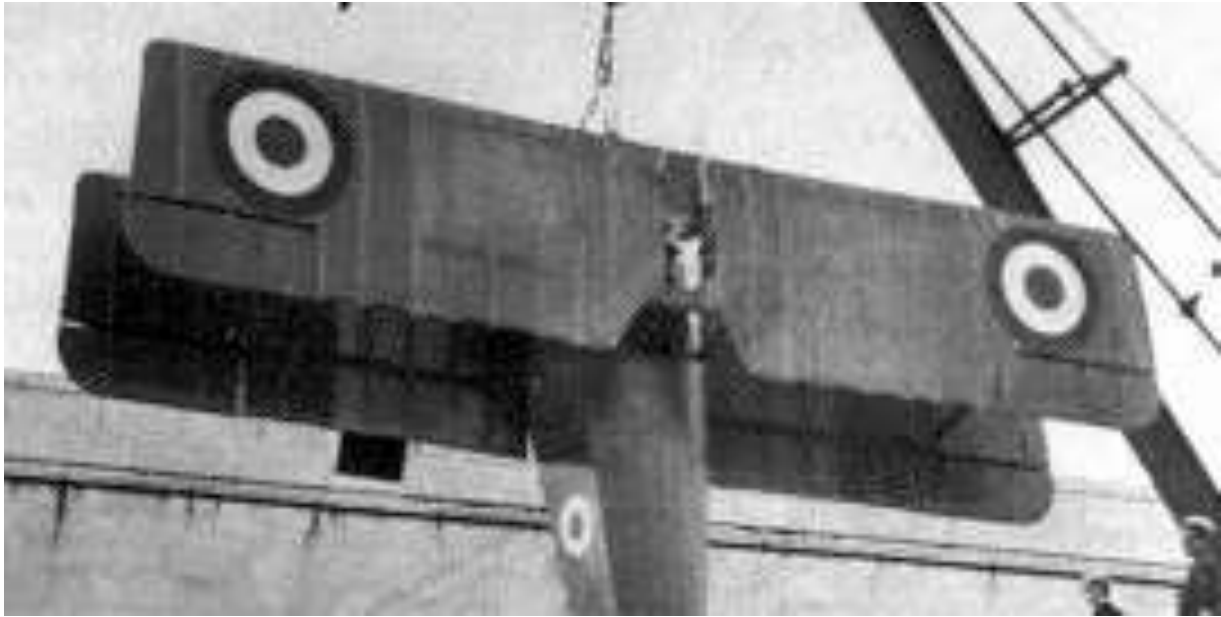

The engine cowl and forward panels on Sopwith built aircraft were characterised by having the metal surfaces spot burnished. Although two Sopwith built aircraft were delivered as specimens (Ser No:8214 and 8215), it's unclear as to whether all of the Italian aircraft built had the spot burnishing. Certainly some photographs clearly show this burnishing having been carried out, but not all photographs are clear enough to say with certainty that all aircraft were burnished. Therefore it's down to the modeller's personal choice whether to represent the burnishing or not.

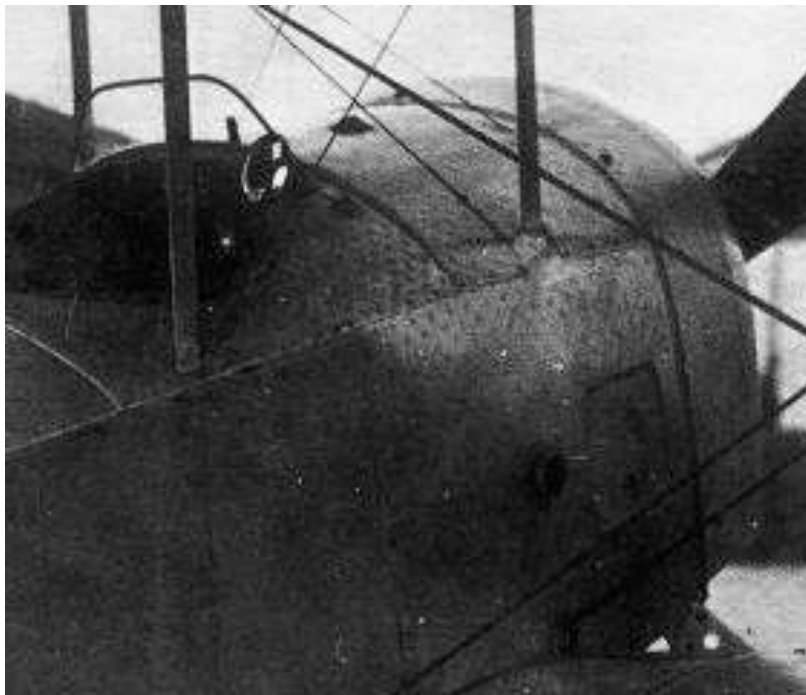

The 'Lukgraph' illustrations also show the support struts for the two floats as being natural metal finish, but other colour profiles show these as being wood. I chose a metal finish as being most likely, common to other aircraft types made by Ansaldo.



This model:

The aircraft being modelled for this build is Ansaldo 'Baby', Ser No: So.5005, which was the first Italian produced aircraft of this design and was built under license by the SA Aeronautica Gio Ansaldo of Turin. The colour illustrations in the 'Lukgraph' instructions show So.5005 as having no weapons fitted and with the tri-colour red and green underwing paint scheme. Interestingly, the Windsock Mini Date file No.15 - Ansaldo Baby (by Gregory Alegi) has some facts on page 2 for So.5005:

1. Two photographs of So.5005 taken outside of the Ansaldo works. The aircraft was positioned in front of large banners, presumably to celebrate the collaboration of Italy and Britain in the production of the 'Baby'.
2. The aircraft is photograph carrying a Lewis machine gun, Nieuport style on the centre section of the upper wing. No bomb rack is visible in the photograph.
3. The bottom of the engine cowl has four cooling vents added to aid in the cooling of the Le Rhône 9J engine, which when enclosed in the original full cowl was prone to overheating.
4. The Windsock text states the overall finish on the aircraft was 'plain'. The poor quality of the photographs make it difficult to ascertain if the usual red and green colours were at that stage applied to the outer undersides of the wings. The aircraft did have the Italian rudder marking and presumably the roundels on the top surface of the upper wing. The textual reference to So.5005 being 'plain' may have been that some aircraft upper surfaces of both wings coloured with PC 10 (drab green).
5. The Sopwith 'Baby was fitted with a 'Lang' propeller, which were fitted to many Sopwith types. Although some photographs of the Ansaldo 'Baby' shown that type of propeller fitted, most were changed to have a propeller fitted that was similar to the Macchi built Nieuport 17 fighters. Some photographs shows metal erosion plates fitted to the tips of each propeller blade. It is uncertain as to the actual manufacturer of this type of propeller fitted to the Ansaldo 'Baby' (refer to the manufacturers logo shown in the following photograph).



Given the information available it is the choice of the modeller as to how this particular aircraft could be modelled.

From production:

1. As shown in the kit instructions - no machine gun fitted with the red and green underwing markings applied and the rest as CDL.
2. As above, but with green applied to the top surface of the lower wings.

In service:

3. Lewis machine gun fitted with red and green underwing markings, green applied to the top surface of the lower wings applied and the rest as CDL..

The Ansaldo 'Baby' was never extensively used for combat operations, as intended, but was relegated to flight training or coastal defence. The service record of So.5005 is not known. It may have been used solely as a training aircraft or could have been used for coastal defence. Therefore it may have retained its Lewis machine gun or had it removed. It is probable that in any event the red and green underwing markings would have been applied at some stage.

For this model build, I chose to use option 1 as showing the aircraft as it may have looked when possibly being relegated to training only.

PART 1
MODEL
DESCRIPTION

PART 1 - MODEL DESCRIPTION

(‘Lukgraph’ - Kit No:610)

This 1:32nd scale model is manufactured by ‘Lukgraph’ and is manufactured primarily in a grey coloured resin, which initially looks like standard styrene. Other parts, such as the engine and engine cowls are 3D printed. The kit supplies the model parts, metal rods, 3D printed parts, decal sheet and the instruction booklet. This particular model is of the Italian Ansaldo ‘Baby’, a licensed built version of the Sopwith ‘Baby’. As the Italian aircraft were not operationally used and were instead used primarily as trainers, this model has no weapons, unlike other Nations, who’s aircraft could be armed with a machine gun and small bomb load.

The kit instruction booklet has seven assembly sheets, two rigging sheets and two colour scheme illustrations. Although fairly brief, the instructions seem to be concise. The front page does state that the aircraft was fitted with a Clerget rotary engine, whereas in fact the Italian aircraft were fitted with the Le Rhône 9J rotary engine, which appears to be the engine that is supplied in the kit anyway. The decal sheet comprises of just the wing and fuselage roundels, serial numbers and the rudder tri-colour, which needs to be cut to shape. Also supplied is a photo-etch sheet for cockpit and external parts and coloured, self-adhesive instrument panels. The windscreen has no transparencies but instead self-adhesive templates are provided to cut your own transparencies from the supplied acetate sheet.



This model is a new release and with new tool moulds there shouldn't be any obvious problems with the model parts, such as can occur with resin kits, such as mis-moulds/short shots, tooling marks, air bubble 'blow holes, heavy resin flash are the parts or warping of parts. However, there are a few minor areas that will need to be addressed, such as slight tooling marks on some parts and the underside of the upper wing centre section looks as though it has suffered with surface distortion around the centre opening and what appears to be a surface crease across the front of the opening. The wing and float support struts have reinforcing rods through them, which appear to be centra, which is good. However, some of the strut rods are so close to the surface, they can be clearly seen through the resin skin, which may cause them to be weaker than they should be and may even suffer break through of the rods.

The main floats are solid mould and do have some small blow holes in the top surfaces. Also the side walls of the float appear to be shrunk back at the edges, which may be by design or possible caused by the cooling of the solid resin (called sink marks on large styrene model parts). The two fuselage halves on my model have a rough bottom seam when the halves are placed together and this will need to be rectified during the build.

The 3D printed engine parts and cowls are defect free and of good quality, although care will be needed when separating the parts from their support trees.

As with most models, there is scope for modifications to enhance the model, using aftermarket parts, such as:

Alternative decals from 'Aviatic' and 'Pheon'.

Resin or metal turnbuckles from 'Gaspatch'.

Any aftermarket additions or modifications will be covered in the relevant Part of this build log.

PART 2
WOOD EFFECTS
(General)

PART 2 - WOOD EFFECTS (General)

A basic technique:

Parts of the model that are supposed to be made of wood can prove to be a challenge to replicate a wood finish to the part. Some after market companies produce accurate wood decals, which can be used to cover larger areas, such as cockpit decking and fuselage panels. However, decals can't easily be used to create realistic wood finish to smaller items or parts that don't lend themselves to having decals applied. To do this requires brush painting, using such as acrylic or oil paints, which can be enhanced with various washes or filters.

The first thing to do is to ensure the model parts are cleaned, normally with warm water with washing up fluid and something like an old tooth brush. Once cleaned and thoroughly dried, the primer coat can be applied. I use 'Tamiya' Aerosol Light Grey (Fine) or White (Fine) acrylic primer. Once the primer is dry, you can start applying the wood effect to the applicable cockpit items, such the cockpit framework, decking, seat supports, rudder bar, instrument panel and of course, the wing struts. With practice, this method can also be used on fuselage panels and propellers.

To start, apply a suitable base colour. For most painting I use an airbrush and only resort to brush painting when dealing with small items, when I add a few drops of 'Mr. Colour' Levelling Thinner', which aids brush painting. For most wood effect, I use 'Tamiya' Wooden Deck Tan (XF78) or Dark Yellow (XF60), suitably thinned with 'Tamiya' Thinners (X20A). Allow this base coat to fully dry (if you can't smell the paint, then it's dry).

Example of base coat using 'Tamiya' Wooden Deck Tan (XF78).

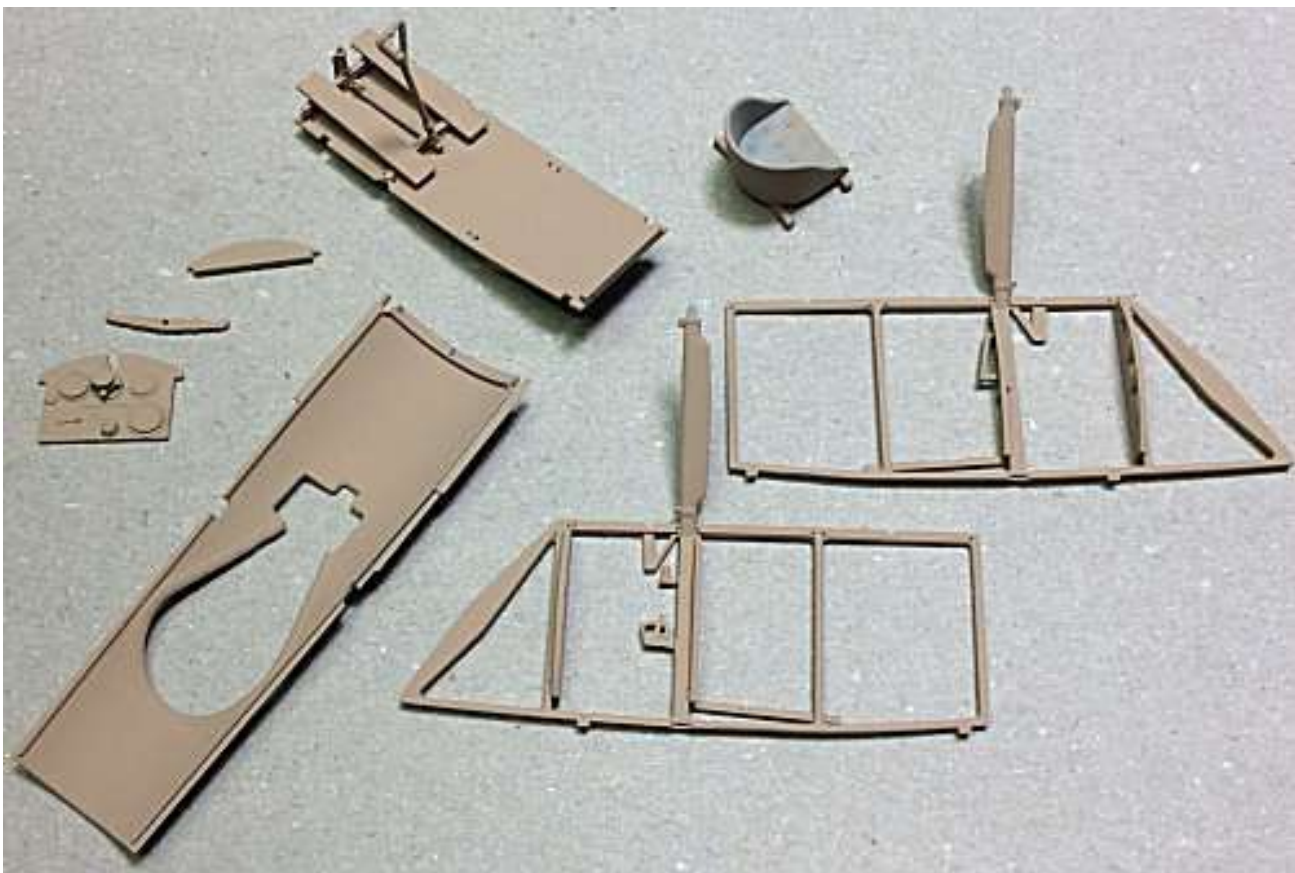

For the next step I use 'DecoArt Crafters Acrylic' paints, either Burnt Umber or Burnt Sienna. These are similar to standard acrylic oil paints, but are water based instead of oil based. This paint is not as thick as oil based paint and is more creamy, so can be brushed and controlled more easily. Also, as it is water based, it's easy to clean your brushes, and if really necessary, can be thinned slightly with water. In addition, the paints dry as quickly as normal acrylic paints, avoiding the disadvantage of using true oil paints, which can take days to fully dry.

Place a small amount of the oil paint onto a non-absorbent surface and using a suitable oil paint brush (I use a slightly curved brush), wipe a small amount of the paint onto the brush. For larger areas, such as decking or panels etc I use a small piece of fine sponge to apply the paint.

Apply the paint to the applicable item, using light strokes and in the required direction. Apply the paint along struts and across instrument panels and other smaller items. This gives variation to the wood effect and for the wing struts, is correct for the direction of the wood grain. If you apply too much paint, just brush or sponge it off immediately before it dries. Although the paint is water based, don't try to thin any applied paint with water as it will lift the paint, which builds up into clumps. If required, a second light coat can be applied. Always wait until a first coat has fully dried before applying a second coat, otherwise the first coat will 'drag' and lift from the surface.

Once painting is complete, clean the brush in water.

Below is an example of the Burnt Umber oil paint applied to a cockpit side frame.



Once the oil paint layers have dried, the final top coats can be applied to give the final effect of varnished wood.

'Tamiya' have 'Clear' coloured Acrylic paints, which are intended to be mixed with either Flat Clear (XF86), Semi-Gloss Clear (X35) or Clear (X22), to give the required finish but with a tint of the added 'Clear' colour. I use the Clear Yellow (X24) or Clear Orange (X26) to add a varnished tint to the clear coat. If using the 'Tamiya' Clear I add 'Mr. Colour' Levelling Thinners, which does improve airbrushing and avoids pooling. Otherwise I use 'Alclad' Light Sheen (ALC-311).

Although it's a lacquer, I've found that it will accept 'Tamiya' 'Clear' coloured Acrylics without any separation, which can happen with other paints. The 'Alclad' lacquers dry fast and provide a good sealing layer over the painted surfaces. When using 'Alclad' sealing coats, the golden rule is to allow the various painted surfaces to dry fully before applying 'Alclad' lacquers.

In this instance, I added a few drops of Clear Yellow (X24) into the 'Alclad' Light Sheen (ALC - 311) and thoroughly mixed it. Only add small amounts to the 'Alclad' in order to control the amount of tint you desire. I increased my airbrush air pressure to around 20 psi to airbrush the sealing coats over the various cockpit items. The first coat usually dries to a more matte finish, which I assume is due to being sprayed onto the oil paint, rather than onto straight acrylic paint. Once this first coat has dried, I airbrushed several coats of just 'Alclad' Light Sheen (ALC -311), which added not only more sealing coats, but more importantly gave the desired semi-gloss 'varnished' finish I was after.

Below is an **example** of the applied 'Alclad' lacquer/X24 mix on the propeller.



NOTE: *Once you are confident using this method of replicating wood finishes, you can vary both the colour of the acrylic base coat and tinting of the sealing coat, to replicate other types of wood used in aircraft construction.*

Once the lacquer coats are thoroughly dry, any detail painting, decals or final weathering can be applied to the parts, as required, prior to fitting them to the model.

PART 3
WEATHERING
(General)

PART 3 - WEATHERING (General)

There are many different types of weathering mediums available now to modellers of aircraft, ships, vehicles and figures, in model of any type. These weathering mediums can be washes based on enamel, clay or ink. Weather pastels, applied by sponge' as well as oil paints of various sorts are also plentiful. Some modellers have even used water colour paints, and pencils. The following are the basic weathering mediums I tend to use on most of my models.

Flory Model clay washes:

The washes I tend to use are the 'Flory Models' Clay Wash 'Grime' and 'Dark Dirt', which come in various shades and consist of a suspended and very fine clay pigment. They are brushed over the surface to be weathered and dry in around 30 minutes. When dry, use either a piece of good, absorbent kitchen roll or a soft brush to remove as much of the clay wash as you need to achieve the desired effect. Once dampened, the dried clay is re-activated and the clay wash can be removed or worked as required.

First I seal the surface with airbrushed 'Alclad' Light Sheen (ALC-311), which dries quickly. A gloss coat tends to stop the clay wash 'gripping' the surface when it is applied and it can run off or just puddle. A matte coat can cause the clay wash to 'grip' too much, making it difficult to remove or even to wash it off completely.

NOTE 1: The more glossy the applied sealing coat is, the more the chance there is that the applied 'Flory' clay wash will not spread fully, but rather form puddles or beads of wash. If this happens, add a few drops of ordinary kitchen washing up liquid to the clay wash. This will break the surface tension of the wash, allowing it spread fully.

NOTE 2: Always decant the amount of clay wash you need, rather than dipping the brush directly into the wash bottle. Dipping into the wash bottle can transfer contaminants from the brush into the wash, will can cause the wash to become thick and unusable.

NOTE 3: When a sealing coat is applied over areas treated with clay wash weathering, the intensity of the applied wash tends to darken. This should be considered when removing the clay wash, otherwise the final effect may appear too dark.

To apply the clay wash is just a matter of brushing all over the surface to be weathered. It doesn't matter really how much is applied as it can be left on for any period, as it is easily removed without any effect on the surface underneath. If you don't achieve your desired effect, you can wash it all off and start again. I use a soft brush, which has been very slightly dampened, to brush off the clay wash. For smearing effects, a very slightly damp brush or absorbent paper should be used, but even then I dab them onto a dry piece of the paper, until it's almost dry. Any wetter and you'll find that you are removing too much of the clay wash. If that happens you would have to re-apply the wash and start again. That said, if you're not happy with the final effect, you can easily remove the clay wash by brushing with a wet brush or even airbrush water over the surface. Dry off the surfaces washed and then re-apply the clay wash and try again until you are satisfied. The technique is to 'damp' brush or wipe over the surface to re-activate the clay wash and at the same time, to smear it over areas that had no clay wash. It'll dry more or less straight away. Then I'll very lightly brush and/or use a piece of damp absorbent paper to remove as much as I want until I get the desired effect. If I remove too much I just reapply clay wash to that area and repeat the removal procedure. Once finished, just run the brush under a tap to rinse out any residual clay pigments. Finally I usually seal the surface with airbrushed 'Alclad' Light Sheen (ALC-311), which will seal in the applied clay wash.

NOTE 4: 'Flory' current range of washes are: Dark Dirt, Grime, Black, Light (white), Mud, Sand, Rust and Concrete. All of these washes can be used as-is or mixed to create many colour shades for weathering.



Chipping effects:

To give the effect of chipped and weathered paint/varnish to metal engine cowls and forward fuselage panels etc, chipping fluids can be used. To achieve this effect, first prime the areas with a suitable primer then airbrush the metallic finish desired. Once dry, a chipping fluid, such as 'AK Interactive' Medium Chipping fluid or 'Vallejo' chipping fluid is airbrushed over the painted areas. An alternative is to use a cheap hair spray. This forms a barrier which will allow the top coat to be chipped off. Finally the required top coat colour is applied.

Once fully dry, moisten the top coat with water, which softens the paint. Then with a cut down (stiff) brush and wood cocktail stick, gently teased off the top coat paint. Take care when doing this as 'too much chipping' can't really be covered up. In that event you would have wet the top coat and remove it all with an old toothbrush or similar and then when dry, re-spray the top coat and try again. Once the desired effect was achieved, I sealed the surfaces with an airbrushed coat of 'Alclad' Light Sheen (ALC-311).



'Tamiya' Weathering Master sets: Each of these 'Tamiya' produced weathering sets contain three 'tablets' of different colours and an applicator, which has a brush on one end and a sponge on the other. The tablets have a wax look and feel and can be applied onto painted surfaces to reproduce various finishes. It's best to use these as the final surface treatment, as being a 'Wax', any treated surfaces can't be painted or sealed.



Pigments: Pigments, such as those produced by 'Flory Models' or 'Humbrol' are effectively very fine 'dusts', which can be applied to a model to re-create dust, dirt, stains etc. They can be applied by dry brushing or mixed with other mediums to create paintable solutions.



Washes: Washes can be applied to either enhance panel lines etc or to add a 'filter' of colour onto a painted surface. They can be purchased ready made from various manufacturers or can be 'home made' using such as oil paints with a suitable thinning agent. I tend to use 'AK Interactive' products.



Water colour pencils:

Water colour pencils can be used to add weathering detail. The colour s applied to the model part then brushed gently with a brush, slightly dampened with water. This dilutes the pencil marking, allowing it to be faded as desired. 'AK Interactive' produce these 'weathering' pencils, which are marketed specifically for the modeller, although other artist water colour pencils can be used, such as 'Derwent' Inktense 24 ink pencils.



Oil paint: A technique used more frequently now is oil paint 'dot and drag'. Basically an oil paint of the desired colour is placed onto a piece of cardboard, which over a hour or so, soaks out the oil in the paint, leaving a drier pigment. The pigment is 'dotted' onto the painted surface where it is required then dragged with a brush previously wetted with 'Tamiya' X20 enamel thinners then wiped virtually dry.

Softly 'flick' the brush to drag the pigment in the direction required, which will blend it in a thin layer.

The amount of pigment left showing depends on the effect you require. Always keep the brush wiped clean to avoid a build up of pigment and remoisten and wipe dry often. The more paint you drag, the less pigment is left showing. Blending different coloured pigments can create stains from smoke/gun blast, rain marks/runs, dirt/dust and oil/fuel stains.

A good quality oil paint and thinners are essential to produce a good finish. Some quality oil paints can be too 'gritty' when leached of oil, so I use 'Abteilung 502' oil paints and 'Tamiya' Enamel thinners (X20).



PART 4
DECALS
(General)

PART 4 - DECALS (General)

Standard decals:

NOTE: *The following is **applicable only** for decals on a **painted surface**. If decals are to be placed on top of **previously applied decals**, the decal setting solutions may 'eat' into the previous decals. In this case a sealing coat of either 'Alclad' Gloss (ALC-310), 'Alclad' Aqua Gloss (ALC-600), Tamiya' Clear (X22) or 'Johnson' Pledge Floor Care finish should be airbrushed over the first decals, to provide a barrier against the setting solutions.*

Ensure the painted surface is smooth and free from any surface imperfections.

Airbrush a sealing coat of 'Alclad' Gloss (ALC-310), 'Alclad' Aqua Gloss (ALC-600), 'Tamiya' Clear (X22) or 'Johnson' Pledge Floor Care finish, to provide a smooth surface.

NOTE: *'MicroSet' solution softens the decal to allow it to conform to the painted surface. Do not attempt to move the decal too much or it may tear.*

Wet the area using a light coat of 'MicroScale' **MicroSet** solution.

Apply the decal after it has soaked in 'warm' water enough to start to loosen the decals from its carrier backing.

Carefully move the decal into the correct position.

Carefully press out any residual water from the decal by either pressing with a tissue or by gently rolling over the decal with a cotton bud.

NOTE: *'MicroSol' solution will soften the decal to allow it to conform fully to the painted surface. The solution usually causes the decal to wrinkle, but this is normal as the decal semi-dissolves to the surface. Once the solution has been applied, never try to disturb the decal as it will tear. Leave the solution for several hours to do its job, after which the decal will return to a smooth surface, but conformed fully to the painted surface.*

Wet the decal surface with a light coat of 'MicroScale' **MicroSol** solution.

Leave the solution for several hours to fully dry and set the decal.

Once fully dry and set, airbrush a sealing coat over the decal, dependant of your desired finish. I tend to use either 'Alclad' Light Sheen (ALC-311) lacquer or 'Tamiya' Semi Gloss (X35).

Once the decal is correctly positioned, use a flat brush to brush the water out from under the decal, working from the centre of the decal out towards the edges. I then use a dry cotton bud in the same manner. Finally, wearing cotton gloves, I apply slight pressure and slide my fingers across the decal to finally push the decal onto the surface.

Once the decals have been applied I airbrush a sealing coat of either 'Alclad' Clear Coat Gloss (ALC-310) lacquer), 'Alclad' Aqua Gloss (ALC-600), 'Tamiya' Clear (X22) or 'Johnson' Pledge Floor Care finish over areas of decals where more decals are to be applied.

Once the decals have been applied and are dry I airbrush a final sealing coat of 'Alclad' Light Sheen (ALC-311) or 'Tamiya' Semi-Matt (XF35) over the decals.

To 'knock back' the sheen for applying weathering effects (refer to Part 3 of this build log), for example 'Flory' clay washes or oil paint, I airbrush a sealing coat 'Alclad' Light Sheen (ALC-311) mixed with Flat (ALC-314) at a 3 to 2 ratio.

'Aviattic' linen effect decals:

The 'Aviattic' decals are different in both production techniques and application to those of the more traditional decal manufacturers. Traditional decals are normally created using processes such as silk screen printing and are pre-shaped for the particular model markings. When placed in warm water they will detach from the backing sheet and can then be slid onto the model surface and when they are correctly positioned, wiped with a semi-dry brush or cotton bud etc, to expel any water from under the decal. Once fully dry, decal softeners, such as 'MicroSol' and/or 'MicroSet' can be applied, if necessary, to 'weld' the decal to the model surface. Finally a sealing coat of acrylic or lacquer gloss, semi-matt or flat is applied over the decal, to seal and protect the seal and protect the decal.

However, 'Aviattic' decals are laser printed onto a very fine carrier film and although this film is thin, the decals are remarkably resilient and somewhat 'stretchy' when being applied. This allows them to be more easily moved and positioned before being finally applied. Also with most other decals, I've used softeners to help the decals conform to surface irregularities and contours, which is something I've found is not really required for 'Aviattic' decals, due to the nature of the carrier film. In addition, the decals need to be cut out from the sheet, so care is required to cut the decals accurately to avoid leaving gaps, especially at the edges, where the white base colour will show. That said, minor gaps may be able to be covered with weathering. For more information, refer to the 'Aviattic' instruction sheet supplied with the decals.

'Aviattic' decals are laser printed onto either 'clear' or 'white' backing, the 'clear' being dependent on the base coat you apply and the finished effect you desire. The decals are supplied with very clear instructions on their application, including when to add pre-shading to the base coat, where desired, before you apply the decals. For this model I chose to use the 'clear' decals, in order to show the linen effect more visibly.

Application:

First airbrush a primer coat of 'AK Interactive' primer and micro-filler (White - AK759) on all of the surfaces to have the decals applied.

NOTE: *'Silvering' is caused by air being trapped in the rough surface of the paint, such as on a matte finish, which after the decal is applied and dries, causes silver sheen patches showing in the decal ('silvering').*

Once dry, check the surfaces for any imperfections, such as trapped dust or raised areas of paint, which will cause 'silvering' under the decals. Any surface imperfections found should be carefully polished out.

Airbrush at least two light sealing coats of either 'Alclad' Clear Coat Gloss (ALC-310) lacquer, 'Alclad' Aqua Gloss (ALC-600), 'Tamiya' Clear (X22) or 'Johnson' Pledge Floor Care finish (similar to 'Future'), all of which will form a gloss surface for applying the decals.

NOTE: *The surface must be pre-wet with like warm water with. Care needs to be taken when you slide the decal from the backing sheet and onto the model surface, as the thin decal can fold over on itself.*

Soak each decal in warm water for approximately 20 seconds.

Wet the surface of the model where the decal is to be applied.

Carefully slide the decal onto the wetted surface. Make sure the decal does not fold over on itself.

Align the decal to the shape of the model part.

Using a broad, soft brush, brush the decal from the centre outwards to remove any water from under the decal.

Adhere the decal to the model part surface by either pressure rolling over the decal with cotton buds or, as I do, by wearing lint free cotton gloves and rubbing the decal with your fingers.

Check to make sure the decal is in full contact with the surface of the model part and that there are no areas exhibiting 'silvering' (trapped air under the decal). If so, gently prick through the decal and apply water then press out the water to adhere the decal back onto the model part.

Also check that there are no lifted decal edges around the model part.

Allow the decal to fully set, preferably overnight. Where decals have been applied to large areas, gentle heating using a hair dryer can accelerate the decal setting time.

Where decals cover location holes or other openings, prick or cut through the decal into the hole or opening then apply 'Tamiya' X20A thinners, which will soften and adhere the decal into the hole or opening. Using X20A can also conform decals around curves edges etc.

Protect and seal the decals by airbrushing a sealing coat over the decals. If more decals are to be added onto the applied decals a gloss sealing coat should be used. Otherwise a sealing coat of the desired finish can be applied, which should also be done once all of the required decals have been applied.

PART 5

RESIN (General)

PART 5- RESIN (General)

This model contains aftermarket resin parts, as opposed to the normal plastic used. The reason for creating resin kits is that in years gone by, resin kits were able to produce much finer detail on kit parts than the plastic kit equivalents. Even today, there are many producers of resin kits and particularly after market replacement parts. However, plastic kit manufacturers have come a long way now and kits, such as those from 'Wingnut Wings' and 'Copper State' are equal to, if not better than resin kits. Manufacturers of resin kits these days tend to make kits to order or have 'limited' runs, although aftermarket parts are usually readily available. Working with resin does present different challenges to the modeller, especially if it's the first time of building a resin kit. The properties of resin differ radically to those of plastic kits. Below I have listed what I have found to be the primary differences for resin kits from plastic kits:

1. When resin kits are cast in their moulds, a release agent is applied to enable the cast resin parts to be more easily removed, which is similar to plastic kit moulding. This release agent can leave a film on the surface of the kit parts, which, if not removed, can prevent paint or adhesives from adhering to the surfaces. The easiest way to remove this film is to carefully and fully wash all of the model parts in warm soapy water, using an old, soft tooth brush, then rinse all of the parts thoroughly and leave to dry. Alternatively wipe the parts with isopropyl alcohol (e.g. 'Tamiya' X20A thinners).
2. Resin, by its nature, is very brittle and can be damaged or broken easily, especially when handling small parts. This is particularly evident when separating the individual items from the resin cast. The best way to remove item is to cut them away with a razor saw, then clean them up afterwards.
3. Once removed from the resin cast, parts will normally have 'resin flash' around or amongst parts, especially small items. This is easily removed with a sharp scalpel blade. Heavier residue can be scraped, filed or sanded away.
4. Plastic kits are assembled using solvent adhesives, which melt the surface where it is applied and 'weld' the joint together. Resin however will not react to this type of adhesive and can really only be glued using CA adhesive. This adhesive reacts to moisture in the air and on the surface to be joined. As most people know, it will also bond skin to whatever it touches, if the skin has CA adhesive on it. Obviously extreme care needs to be exercised when assembling resin kits using CA adhesive.
5. Cutting, sanding and drilling resin will create swarf and more importantly, resin dust. The dust in particular is dangerous, especially if inhaled. Therefore always vacuum the working area, and yourself, regularly. If you have a face mask or filtered respirator and find you can wear it whilst working, then do so. Resin can easily be drilled or scraped, but remember how brittle resin is when it is being handled.
6. It is not unusual to find imperfections in resin cast parts, such as surface blemishes, small 'blow' holes or ragged edges. This can be common on some resin kits. These imperfections can be rectified by sanding/polishing and/or filling with modelling putty, then sanding/polishing.
7. Generally CA adhesive is supplied as 'instant bond' adhesive, but there are some manufacturers, such as 'VMS Fleky', that supply CA adhesive as standard, thin, slow and specific resin adhesive. Whichever adhesive is used you must ensure parts are correctly positioned and aligned before applying the adhesive. Trying to separate mis-aligned parts once the adhesive sets will prove very difficult and may result in irreparable damage to the parts.

NOTE: To separate resin parts from the thin moulding backing sheet, use sharp scissors or a scalpel blade. To separate larger parts from the moulding base block, use a fine modellers saw. The saw I use has a double sided and fine 'drag' saw blade and with its holder is available from 'RB Productions'.

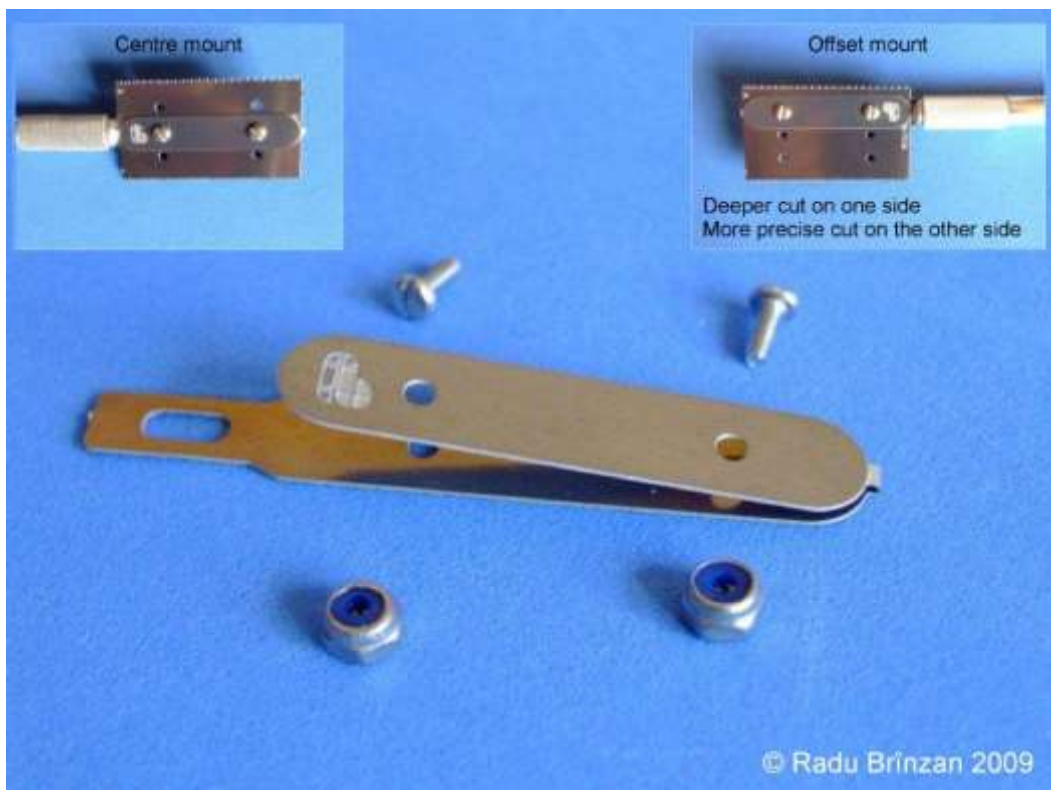
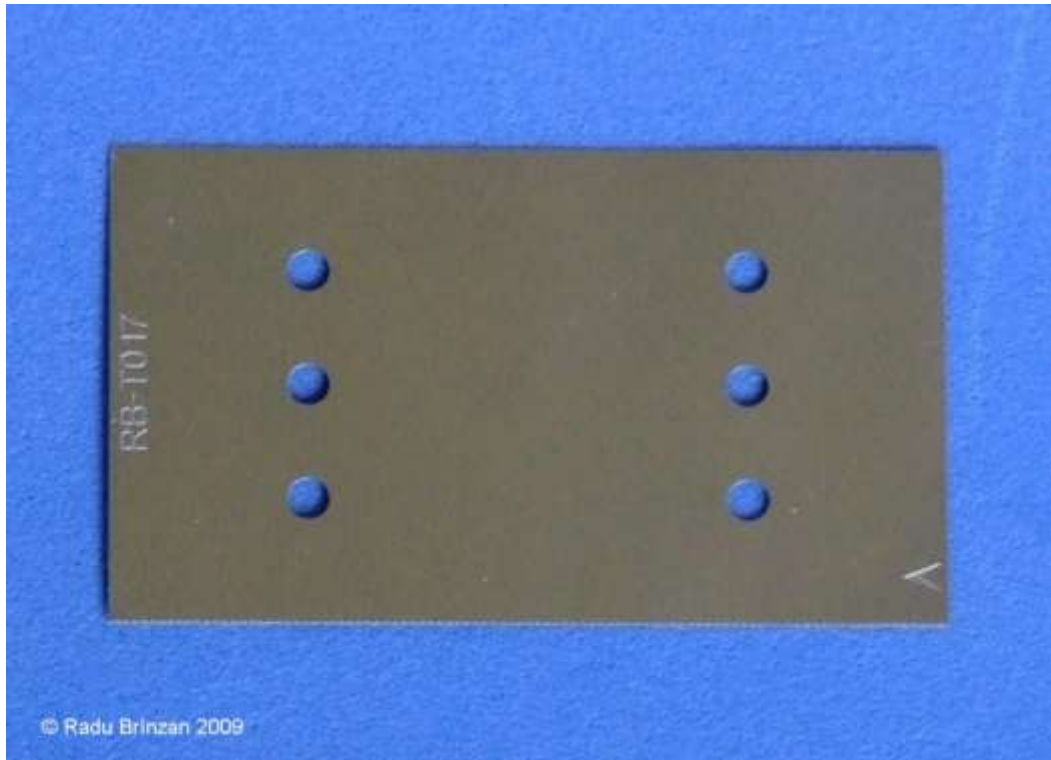

PART 6
RIGGING
(General)

PART 6 - RIGGING (General)

General:

The first thing to check is that you have already drilled out the rigging attachment points. Most models have these located on the model, but it's best to carry out research in reference books or research on line before drilling. Some modellers use micro drills manufactured for drilling printed circuit boards etc and these drill bits sometimes have identifying coloured collars fitted to the drill shanks. I have found that care needs to be taken when using these drills, as they are sharp and instead of easing their way into the plastic of the model, they tend to bite in and effectively 'cork screw' their way in, which causes jamming and lots of broken drills. This is not only expensive but can leave broken drill bits in the model, which are virtually impossible to extract. An alternative is to use High Speed Steel (HSS) drill bits, which are cheaper and have less 'bite' when in use, although again, they are very fragile and can very easily be broken. Some modellers drill through the wings etc of the model and rig by pulling through the rigging line/EZ thread etc, gluing in position and then rubbing down the exposed line 'tag' and then re-painting that area. I prefer to drill only part way into the plastic and attach the applicable rigging fixture with CA adhesive.

With your research complete and all necessary holes pre-drilled, the rigging can start. For the primary rigging, such as flying and landing wires and cross bracing wires, I used 'Steelon' mono-filament (fishing line) of 0.12 mm diameter and for flight controls I used 'Stroft' 0.08 mm diameter mono-filament. These are effectively transparent but do give a look of steel, without the need of painting or colouring with a gel pen. The turnbuckles used are either sintered metal or resin and obtained from 'Gaspatch Models'.

NOTE: *Aircraft of the Royal Flying Corps (RFC) and Royal Naval Air Service (RNAS) used streamlined rigging wires, know as RAF wires, as opposed to the standard wire wound cables. These RAF wires were solid forged lengths with a right hand thread adjuster at one end and a left hand adjuster at the other, so the wire could easily be tensioned and locked. Therefore the rigging fitted to the British Sopwith 'Baby' should be RAF wire. However, photographs of Italian built aircraft seem to show that standard wire wound cables with turnbuckles were used instead. This may have been due to lack of spares or that the increase in speed due to the reduction in drag was not deemed important for an aircraft that was not used operationally, but primarily for training. Therefore I chose to fit wire wound cables with turnbuckles as the rigging for this model and the location of the turnbuckles was based, as best I could, on photographs taken at the time. Museum and 'Composite' restorations, such as that of the aircraft at the Fleet Air Arm museum at Yeovilton, UK, were not taken into account.*

Elevator control wires

A lower elevator control wire is routed through both of the fuselage rear sides and connected to lower control horns on the elevator itself. An upper elevator control wire is routed through both sides of the top, rear of the fuselage and connected to upper control horns on the elevator itself. Moving the control column, to which the wires are attached, either forwards or rearwards causes the elevator to raise or lower and the aircraft to pitch up or down (climb or dive). The elevator wires had no external turnbuckles as adjustment was carried out inside the cockpit.

Aircraft rudder control wires

Two rudder control wires are routed through both sides of the top, rear of the fuselage and connect to control horns on each side of the rudder post. Moving the cockpit rudder bar left or right causes the rudder to turn in that direction, causing the aircraft to yaw left or right. The rudder wires had no external turnbuckles as adjustment was carried out inside the cockpit.

Aileron control

The pilot operated the ailerons on the wings by turning the pilot's wheel on the control column. The typical aileron control from a pilot's wheel was effected by cables. The control column would be fitted with two cable pulleys, one from the wheel and located on the top of the control column and a second pulley located at the bottom of the control column. The aileron control cable run was routed around the top pulley then down to the bottom pulley, where the cable run was crossed. From the bottom pulley the cables were routed out of the cockpit and through the lower wings to their respective ailerons. The aileron control wires are routed from the underside of the lower wing back to the aileron control horns then up through the aileron to the underside of the upper wing ailerons. The wire were then routed through the upper ailerons to their control horns, the forward over the upper wing and round external pulleys. The continuous wire is then routed across the leading edge of the upper wing, through wire guides. A turnbuckle was fitted at the bottom of the control wires that passed between the upper and lower wings. As the control column wheel is turned either left or right the ailerons on either side of the aircraft to move in opposite directions (up or down), causing the aircraft to roll left or right.

Rudder control wires

Two rudder control wires for the float rudder are routed through both lower, rear sides of the fuselage and connect to control horns on each side of the float rudder post. Moving the cockpit rudder bar left or right causes the float rudder to turn in that direction, causing the aircraft to steer left or right when on the water.

Landing wires

A **single** landing wire is attached between the bottom of each outer wing support strut and the top of each fuselage cabane strut on that side of the aircraft. The same applies to the opposite side of the aircraft. Turnbuckles were fitted to the wires at the bottom of the wing outer struts.

Flying wires

A **pair** of flying wires are attached between the top of each outer wing support strut and the wing root of the lower wing on that side of the aircraft. The same applies to the opposite side of the aircraft. Turnbuckles were fitted to the wires at the wing roots.

Bracing wires

The extensive bracing wires on this aircraft are as follows:

Outer wing support struts

Two bracing wires are diagonally crossed between the top and bottom of the wing outer support struts, on both sides of the aircraft. Turnbuckles were fitted to the bottom of the wires.

Fuselage cabane struts

Two bracing wires are diagonally crossed between the top and bottom of the fuselage cabane struts, at both sides of the aircraft and between the forward cabane struts. Turnbuckles were fitted to the top of the wires. Cross bracing was also fitted between the front struts with a centre 'acorn'.

Main floats

Two bracing wires are diagonally crossed, through 'acorn' centres, between the top and bottom of the forward float support struts. The same applies to bracing wires fitted between the tail float struts. The two bullet guides were also attached to each other by a metal rod. Turnbuckles were fitted to the top of the wires. Also the bottom of the two forward float support struts were attached by a bracing wire routed out the underside of the outer, forward wing support struts. Turnbuckles were fitted to the top of the wires.

Tail float

Two bracing wires are diagonally crossed between the top and bottom of the forward float support struts. The same applies to bracing wires fitted between the tail float struts and between the sides (front to rear struts). Turnbuckles were fitted to the top of the wires.

Fin

At each side of the tail unit, a single wire is connected between the top of the tail float rudder post to the underside, trailing edge of the tail plane. Above the tail plane there are two bracing wires that attach to the top of the fin. The same applies to the other side of the aircraft. Turnbuckles were fitted to the bottom of the wires.

NOTE: *The rigging illustrated on three separate pages in the instruction booklet should be used as a guide to the rigging of the aircraft. However, a general model view is shown on the following page for general information.*



PART 7

ENGINE

PART 7 - ENGINE

The Italian aircraft were produced using two Sopwith provided aircraft (Ser No: 8214 and 8215) as specimens, both powered by Gnome Monosoupape 100 hp rotary engines. However the Italian versions were fitted with the Le Rhône 9J rotary engine (120hp) with a circular engine cowl, which needed to have cooling openings cut into the cowl to prevent overheating of the engine.

The engine supplied in the kit is totally 3D printed and to a good surface finish with very little obvious striations, that can be associated with 3D printed components. Also supplied are metal rods for use as the valve push rods.

NOTE: *Take care when separating the model parts from the 3D printed support frames.*

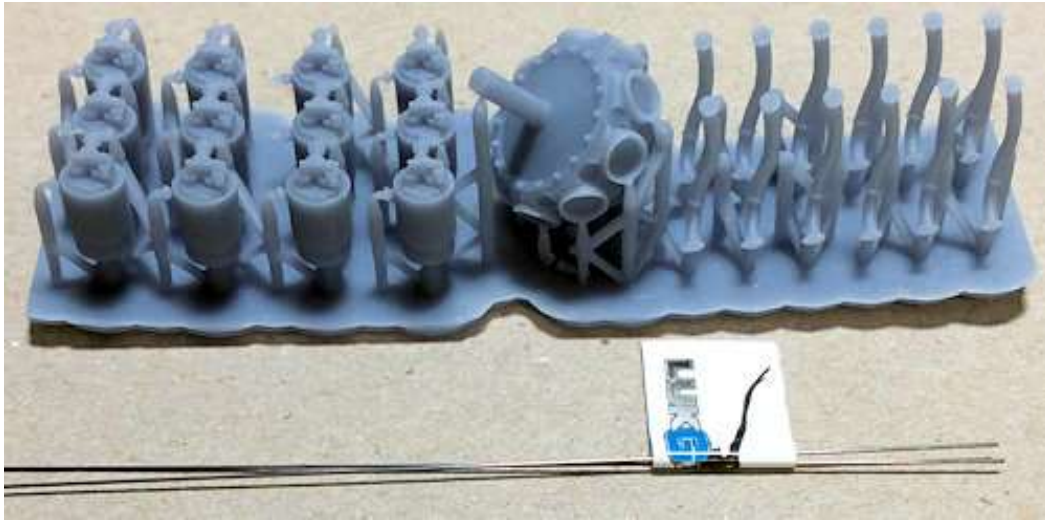

NOTE: *As this model is resin, all assembly of parts must be done using CA adhesive.*

Carefully separate the engine cylinders, engine block and induction pipes from their 3D printed support frames. Spare parts are supplied but only nine cylinders and induction pipes are required.

Carefully sand away any stubs on the parts from the 3D support trees.

Drill a hole of 0.4 mm diameter into each of the nine push rod recesses, behind the cylinders.

Secure the nine cylinders to the engine block. Make sure the cylinders are fitted in the correct orientation (refer to the instructions illustrations).

Airbrush the engine assembly and the nine induction pipes with a black primer (e.g. 'Alclad' Black Base (ALC-305-60) or similar).

Airbrush the engine assembly with steel (e.g. 'Alclad' Steel (ALC-112) or similar).

Airbrush the nine induction pipes with copper (e.g. 'Alclad' Copper (ALC-110) or similar).

Secure the nine induction pipes in position. The bottom of each pipe locates into the recess at the rear, base of the cylinders and the top of the pipe locates against the inlet 'flat' on the cylinder head.

NOTE: *The two 0.3 mm diameter rods supplied in the kit are made of steel and can only be cut to length using snips. This leaves a burr of metal on the rod which is difficult to remove to allow the rod to fully locate into its pre-drilled hole in the engine block. Therefore I chose to discard the kit supplied rods and instead use 0.3 mm diameter Nickel-Silver tube (e.g. 'Albion Alloy's' NST04 or similar). The tube is easy to roll cut under a straight scalpel blade which leaves no burr at the cut end.*

Cut a 10 mm length of 0.3 mm diameter Nickel-Silver tube (e.g. 'Albion Alloy's' NST04 or similar) long enough to be located into its pre-drilled hole in the engine block, then lifted slightly to rest against the underside of the vale lever on the top of the cylinder.

Locate the tube in position and secure.

Repeat to add tubes, representing the valve pushrods, to the remaining eight cylinders.



Cut nine lengths of 0.125 mm diameter copper wire (or similar).

Loop each wire over a 0.6 mm diameter drill shank, grip both ends of the wire together then twist the wires to form a 'rope' effect with a drill loop at the end.

Locate the loop on the wires over the spark plugs with the free end laying against the rear and chamfered face of the engine block.

Secure the wire at both ends.

Cut away the excess wire at the engine block ends.

Brush paint the spark plug in each cylinder with 'Tamiya' Deck Tan (XF55) or similar.

Sponge 'Tamiya' Weathering Master Set D (Burnt Blue) around the tops of each cylinder.

Sponge 'Tamiya' Weathering Master Set C (Silver) over the valve gear on the cylinder heads.

Sponge 'Tamiya' Weathering Master Set C (Gunmetal) over each copper induction manifold.

Brush a light and thinned (with White Spirit) 'AK Interactive' Kerosene (AK-2039) over the engine.



PART 8
WEAPONS
(Information only)

PART 8 - WEAPONS (Information only)

NOTE: *Although this particular aircraft was initially built to carry a Lewis machine gun, the 'Lukgraph' kit of this aircraft does not provide for any weapons. This is probably because these aircraft were not used operationally, as originally intended, but were mostly relegated to the training role at various flight training schools. In addition, there is very little information available as to how the weapon was mounted and used on these Ansaldo built aircraft. Therefore no weapons have been added to this model and the following is general, back ground information only.*

This particular Ansaldo 'Baby', Serial No. So5005, was initially built to include a Lewis machine gun mounted on the centre section of the upper wing, similar to the French Nieuport fighters and indeed the Sopwith built 'Baby's'. Although the 'Lukgraph' model of the Sopwith 'Baby' includes this weapon, the Italian Ansaldo model does not. Therefore the weapon and its mounting need to be created. The lack of the weapon is most likely due to the fact that the Italian built aircraft were not operated as originally intended, but were relegated to flight training duties and it's probable that weapons were not required and therefore removed.

Information or photographs of the weapon and its mounting are rare, but the following are of So.5005 after being built.

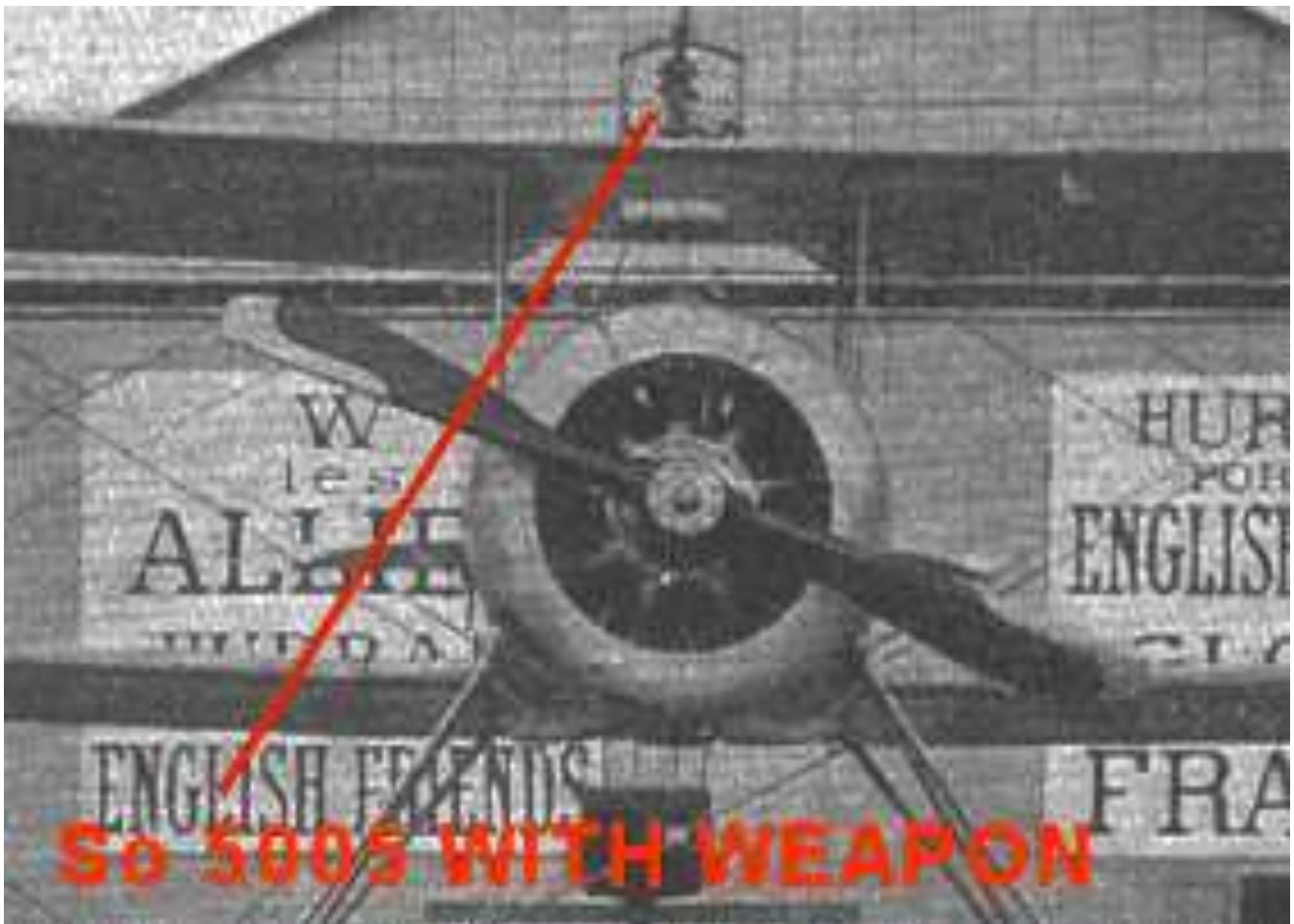

The centre section in the upper wing of the Ansaldo built 'Baby' had a rectangular cut out, which I believe was a Sopwith 'Baby' requirement, so as to have a Lewis machine gun angled up through the cut out. The previous photograph of So.5005 seem to suggest the machine gun was mounted Nieuport fashion, possibly to allow the weapon to be tilted back for reloading and then relocated into the mounting for firing.

On this particular aircraft, the weapon and its mounting appear to be similar to that of the Italian built Nieuport designs, as can be seen on the following photograph, although this is of a later Lewis Mk.III machine gun.

NOTE: *The following photograph shows a Lewis machine gun fitted to an Italian built Nieuport fighter. This aircraft had a no cut out in the centre section of the upper wing, as did the Ansaldo built 'Baby'.*



The rear mounting for the weapon appears to be a tubular pyramid base with a pivot arm at the top and attached to the weapon, which allowed it to be tilted back and down towards the cockpit.

The front mounting had two upright supports, which had angled reinforcing bars at the base. The two uprights were joined together by a curved gun locating bar, which had a central location for the gun barrel.

The photograph does appear to show any extra wire bracing for the gun mounting.

The trigger cable for operating the machine gun is attached through the lower hand grip to the trigger.

PART 9

PROPELLER

PART 9 - PROPELLER

References:

1. Windsock Mini Date file No.15 - Ansaldo Baby (by Gregory Alegi).
2. Windsock Date file No.60 - Sopwith Baby (by J.M Bruce).

The Sopwith 'Baby' was fitted with a 'Lang' propeller, which were fitted to many Sopwith types. Although some photographs of the Ansaldo 'Baby' show that type of propeller fitted, most were changed to have a propeller fitted that was similar to the Macchi built Nieuport 17 fighters. Photographs show metal erosion plates fitted to the tips of each propeller blade.

Example of a typical Nieuport type propeller with canvas sheathed tips.



So.5005 fitted with Nieuport type propeller with metal sheathed tips.

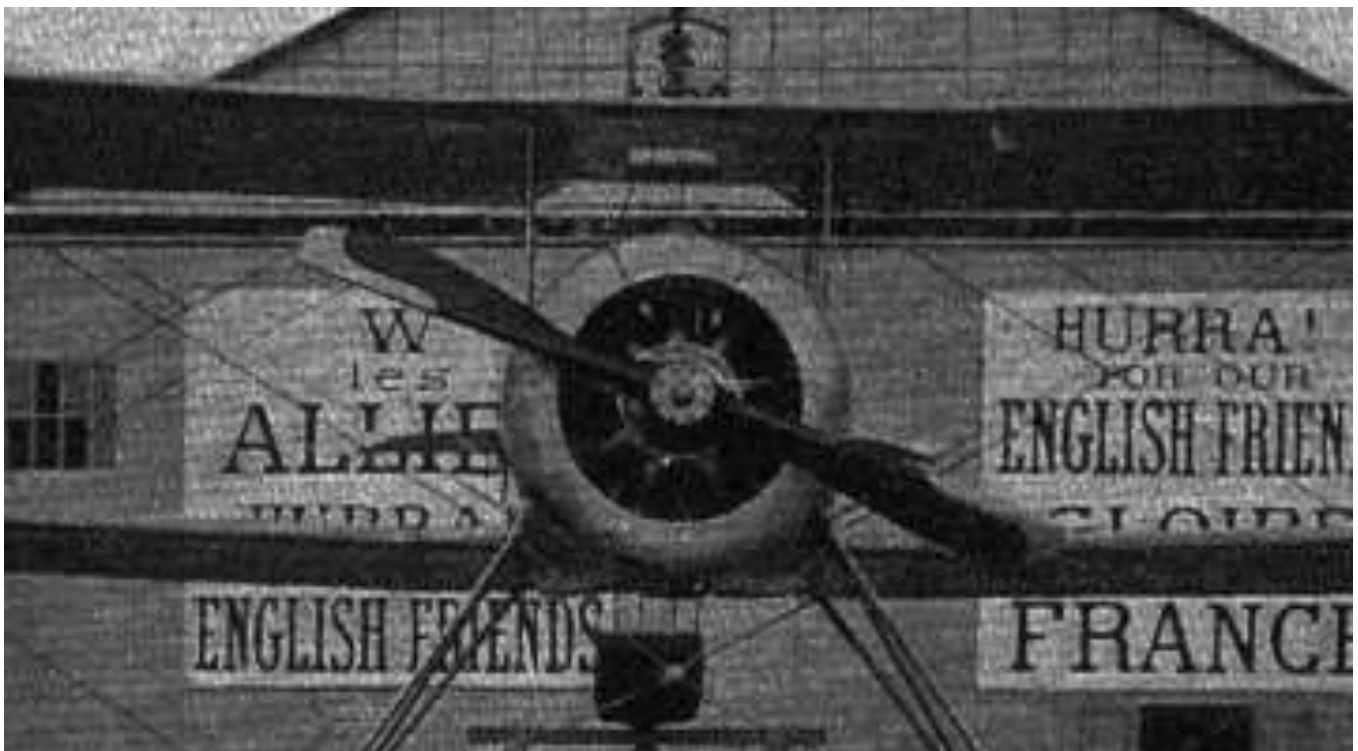

NOTE: *The kit supplied propeller lacks detail as it seems to have the metal sheathing mould only on one side of the propeller tips. Therefore I chose to have the propeller hand made from wood veneer with metal sheathing by Alex at 'ProperPlane'.*

Carefully cut off the two supplied resin propeller bosses from their moulding block.
Sand the mounting faces to the correct thickness.
Brush paint the two propeller bosses with 'Mr. Metal Colour' Stainless Steel (213).
Position the front boss onto the propeller and secure in position with CA adhesive.
Position the rear boss onto the propeller and secure in position with CA adhesive.
Drill out the rear boss to 2.1 mm diameter so it can fit onto the engine propeller shaft.
Lightly sponge 'Tamiya' Weathering Master Set C (Gun Metal) over the brass tip sheaths. This will dull the bright surface finish to a more weathered look.
Lightly brush 'AK Interactive' Kerosene wash (AK 2039) over the front and rear propeller boss.



PART 10
GROUND
EQUIPMENT

PART 10 - GROUND EQUIPMENT

The ground equipment for this aircraft comprises the beaching trolley, one tail float trestle and two main float trestles. The trestles are made up of the parts and the beaching trolley three parts and two wheels. I found that one of the side rails for the beaching trolley was broken so I decided to reinforce both side rails.

Trestles:

Remove any resin flash from the trestle parts.

Secure the cross beams of each trestle to their 'V' frame legs.

NOTE: *During the next step and if required, sand the bottom of the trestle legs to ensure the trestles are level when placed on a level surface.*

Make sure that:

All of the legs of the three trestles make contact when stood on a level surface.

The two main float trestles are the same height.

The beams of all three trestles are level when stood on a level surface.



Beaching trolley:

Remove any resin flash from the beaching trolley parts.

Cut the wheel axle rods such that the wheels can be located on the rods and against the axle blocks.

Drill through the pre-moulded side frame locations in the axle block to a diameter of 1.6 mm.

Cut two 10 mm lengths of 1.6 mm diameter tube (e.g. 'Albion Alloy's' MBT16 or similar).

Insert the tubes into the pre-drilled holes in the axle blocks, leaving the same amount exposed at each side.

Secure the tubes in position.

Cut through the centre of the top rail of the side rails.

Cut two 17 mm lengths of 1.6 mm diameter tube (e.g. 'Albion Alloy's' MBT16 or similar).

Locate the bottom ends of the side rails into the axle block tubes then locate the two ends of the upper rails into the 17 mm tubes.

Hold the side rail assemblies vertical to the axle beam and centre the 17 mm tubes on the upper rails.

Secure the tubes and rails in position.



Painting:

Airbrush prime the three trestles and the beaching trolley/wheels with a grey primer, such as 'AK Interactive' Grey (AK758) or similar.

Airbrush 'Tamiya' Flat Earth (XF52) slightly thinned with X20A, over the three trestles and the beaching trolley.

Brush paint the two guard rails in the beaching trolley, including their clamps to the axle, using 'Mr. Colour' Stainless Steel (213).

Brush over the three trestles and the non-metal parts of the beaching trolley, with 'AK Interactive Wood Wash (AK263).

Sponge brush 'Tamiya' Weathering Master (Set E - Grey) over the three trestles and beaching trolley (to age the look of the wood).

NOTE: *To airbrush the internal face of the wheels without over spraying the surrounding tyres, I use a circle drawing tool (Linex 1217 T). I selected the correct size of hole and position the wheel face under the hole.*

Example only

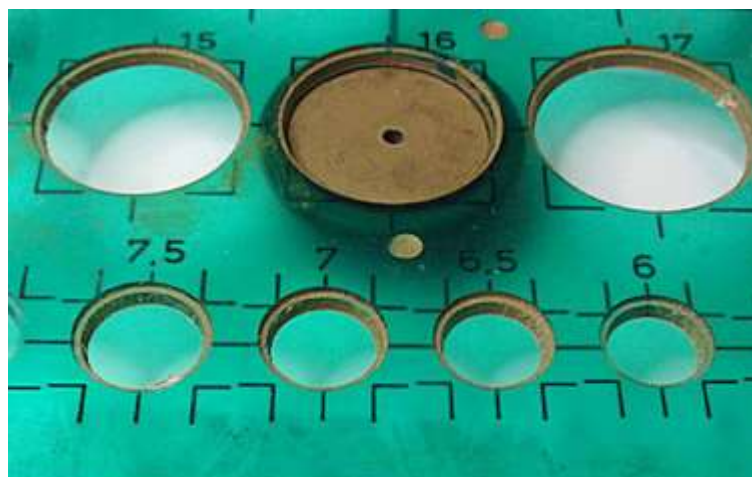

Airbrush 'MRP' Clear Doped Linen (MRP256) over the wheel covers on both sides of the two wheels.

Airbrush the wheels with a semi-matte coat (e.g. 'Alclad' Light Sheen ALC-311 or Semi-Matte (312) or 'Tamiya' Semi-clear X35 or similar).

Refer to Part 3 (Weathering) of this build log for more information - Apply 'Flory Models' Weathering clay wash (Dark Dirt) over the wheels.

Remove the weathering wash to achieve the desired finish.

Seal the applied weathering by airbrushing the surfaces with a matte coat (e.g. 'Alclad' Matte ALC-313 or 'Tamiya' Flat XF86 or similar).

Secure the wheels onto the beaching trolley axle rods.

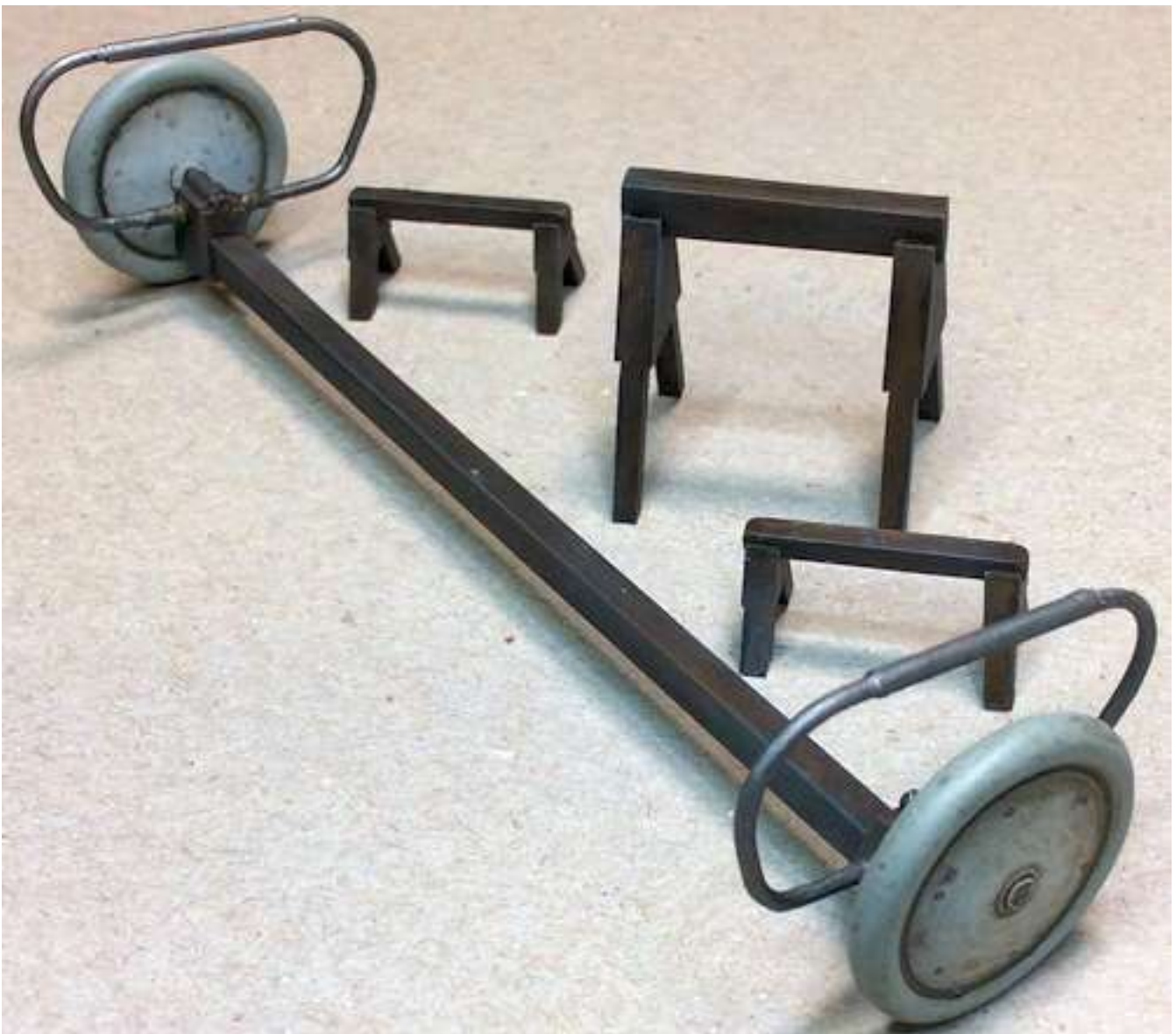

PART 11

PREPARATION

PART 11 - PREPARATION

NOTE 1: *As this model is resin, all assembly of parts must be done using CA adhesive.*

NOTE 2: *Some of the enhancements or corrections to the kit parts can only be carried out during the assembly phases. Corrections or enhancements carried out in this Part of the build log are as follows.*

General.

Kit mould 'flash', rough or badly fitting joints and seams, moulding artifacts, such as surface blemishes and air 'blow' holes - all need to be rectified before any assembly is attempted.

Fuselage halves.

General:

The two halves of the fuselage have small air 'blow holes', which need to be filled and sanded smooth, either by using a modelling filling putty or a thicker filler, such as 'Mr Surfacer' 500.

The gap at the lower wing roots to wing needed to be increased and rough, chipped edges removed.

The mating faces, particularly the underside, needed to be sanded and the two halves checked for full contact.

The sticky 'Lukgraph' tapes used for holding the halves together during transit leave a residue when removed, so this needs to be removed.

The carburettor air intakes at the forward side of the fuselage halves are moulded solid so need to be drilled out and through the fuselage.

The two strut location holes in each fuselage half for the tail float drilled out using a 0.6 mm diameter drill. Make sure you don't drill through the side of the fuselage.

The two fuselage halves have pre-moulded external linen stitching, which is not very realistic. Also the stitching at the sides of the cockpit was not present on the aircraft. In addition, the removable rear fuselage was attached to the forward fuselage at a joint to the rear of the cockpit. This joint has been moulded on the fuselage halves but in reality did not look like this (see the following photograph). The joint at the fuselage sides was covered with a strip. These details need to be scraped and sanded away, in preparation for being replaced with photo-etch stitching from the 'Eduard' WW1 Stitching (EDP32228).

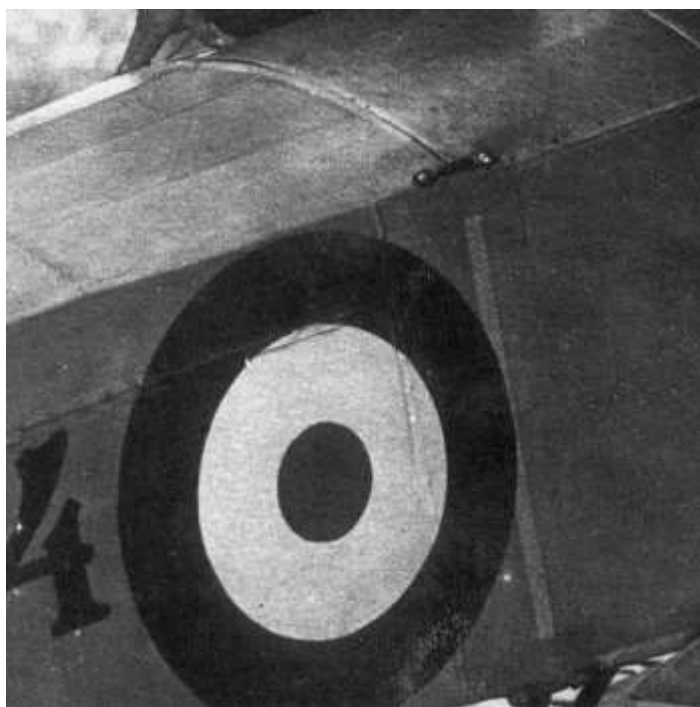

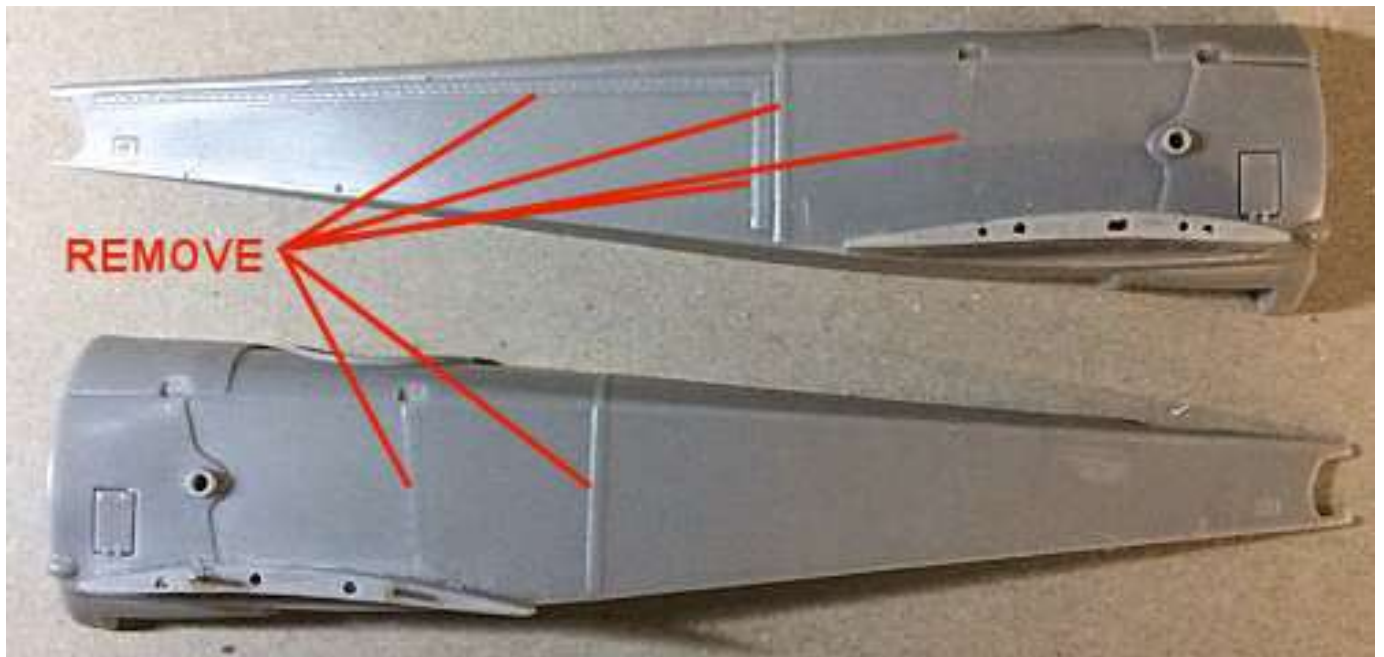

Alignment:

I decided to sand away the two pre-moulded fuselage locating pegs as they tended to mis-align the fuselage halves when test joined. After sanding away the location pegs, I drilled 0.9 mm diameter holes into two locations at the front fuselage joint and one at the lower rear of the fuselage at the original peg location. Brass rods of 0.8 mm diameter were secured into the drilled holes. Three holes of 0.9 mm were then drilled into the opposite fuselage half and at the corresponding positions.

After checking the fit and alignment of the two fuselage halves, it was found that the two halves did not align correctly below the cockpit area. Also the joint seam would show at the bottom of the cockpit once the fuselage was completed. Therefore to ensure full alignment of the fuselage halves, I used CA adhesive to attach short strips of 0.8 mm thick plastic card at various positions around one fuselage half and at positions that would not interfere with the fitting of the cockpit.

Cockpit seam:

To hide from view the joint seam below the installed cockpit, I cut and profiled a single piece of 0.8 mm thick plastic card, which after test fitting, was secured fully to the floor of the left fuselage half.

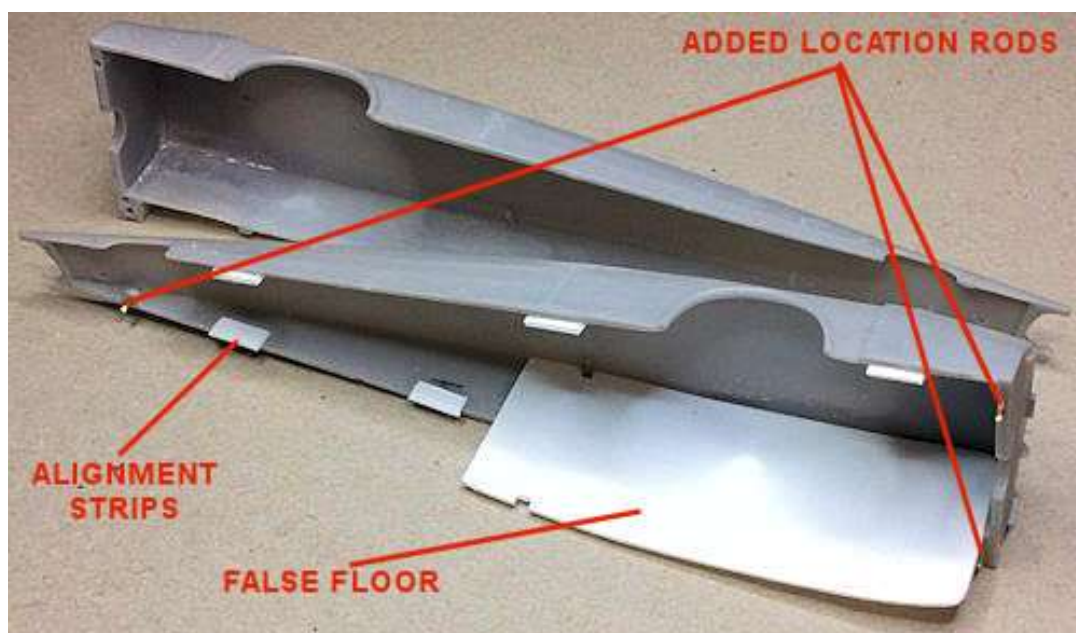



Wings.

The four wing sections are moulded with a steel locating pin and two resin locating lugs that are intended to locate into three holes in the wing roots of the lower fuselage halves and both sides of the upper wing centre section. When test fitted the wings were mis-aligned as the resin locating lugs were slightly out of position. Therefore the lugs were removed and 0.9 mm diameter holes drilled to replace the lugs. Brass rod of 0.8 mm diameter were inserted and secured in place. Finally when located using the added rods and the original kit steel rods, I found that some wing trailing edges were slightly out of alignment. These were sanded to blend with the trailing edges. The wing strut locations were drilled out using a 0.9 mm diameter drill, making sure not to drill completely through the wings. The locations for the fuselage cabane struts to the underside of the upper wing location centre section were drilled out using a 0.6 mm diameter drill. These were drilled through as the four photo-etch lifting points will be secured into the holes in the upper surface of the centre section.

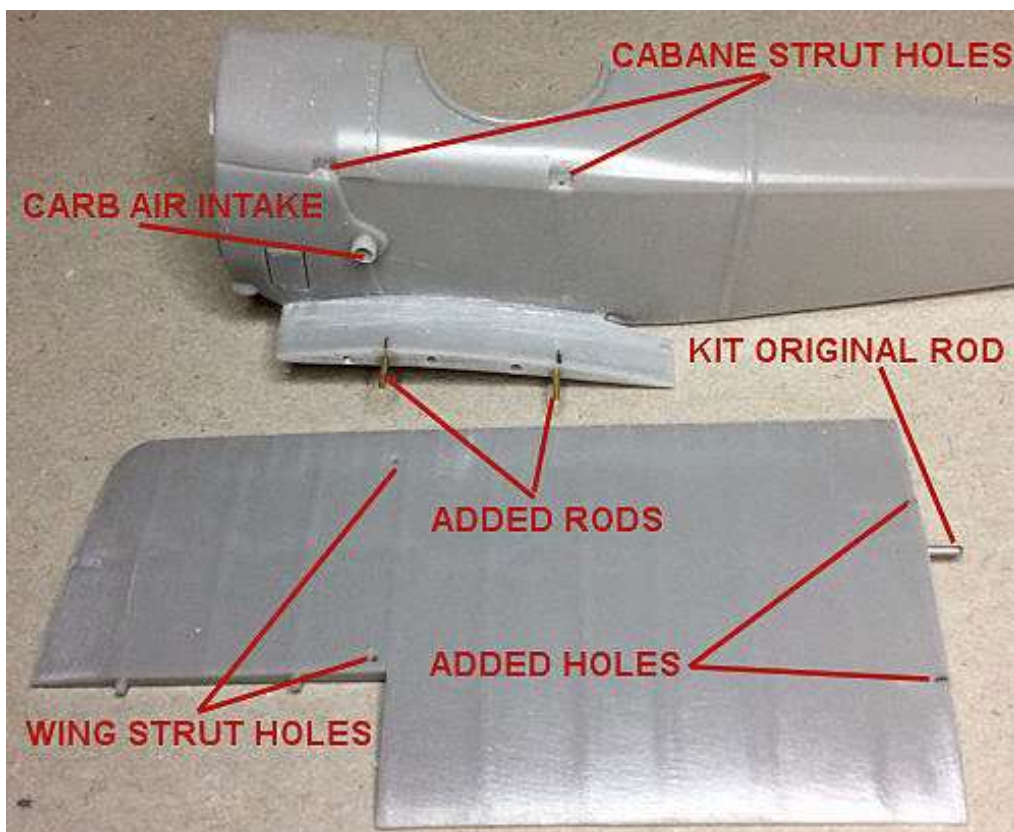

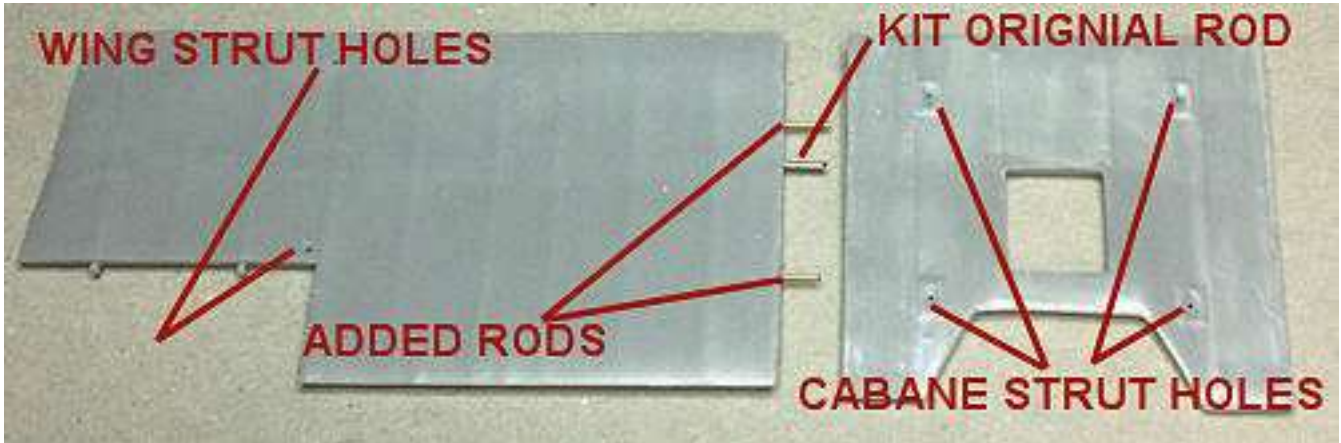
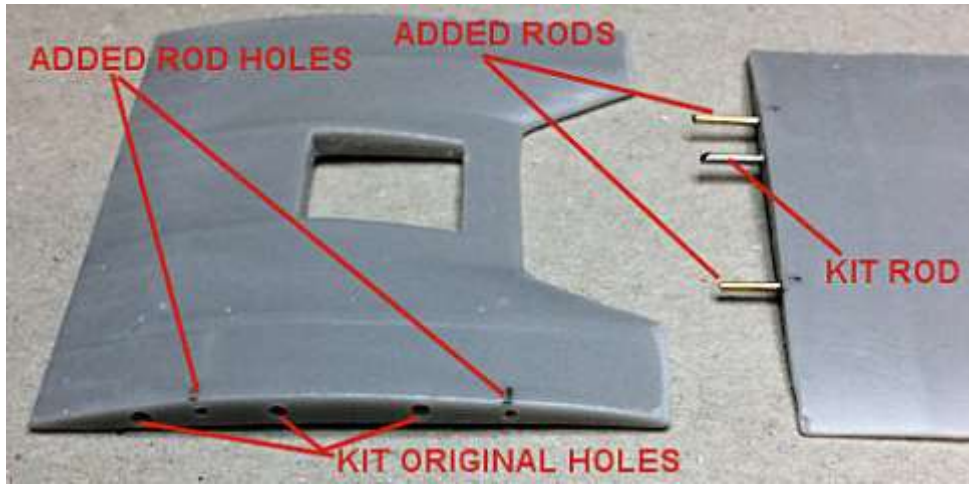

Aileron control horns:

Cut out the kit supplied photo-etch control horns (22 x 4).

Drill holes of 0.5 mm diameter into, but not through, the top surface of the two upper wing and the underside of the two lower wing ailerons and at the leading edge of the middle rib tapes.

At each drilled hole, use a sharp chisel to create a slight cut centrally along each hole (to add a location slot for the control horns).

Secure the four (22) control horns, into the pre-drilled holes and slots.

Aileron control run:

NOTE: *The instructions appear to be incorrect with regard to the external control run for the four ailerons.*

1. *There should be an interconnecting control wire between the rear of the control horns of for the two ailerons, at each side of the wings. Therefore holes need to be drilled through the ailerons.*
2. *The location of the two aileron pulleys on the top surface of the upper wing should be just outboard of the second rib tape from the wing tip, not just inboard as indented on the upper wing.*
3. *The instructions show six photo-etch 'lifting points' on the top surface of the upper wing. The four on the centre section of the wing, above the fuselage cabane struts are correct. The two located midway along the leading edge were never fitted on either the Sopwith or Ansaldo built aircraft and I believe were intended to represent guides for the aileron control wire. Therefore the two aileron control wire guides need to be added to the upper wing and be more in-scale.*

Drill a hole of 0.3 mm diameter through each aileron, approximately 4mm from the trailing edge of the rib tape and aligned with the control horn.

Drill a hole of 0.5 mm diameter into, but not through, the underside of the lower wings, approximately 8 mm from the leading edge of the wings and aligned with the aileron control horn. The holes should be drilled at an angle to align with the top of the lower aileron control horns.

NOTE: The aileron control wire, when fitted, should be parallel to the wing leading edge. To allow for the diameter of the two pulleys, the holes need to be drilled **8 mm** from the leading edge for the pulleys and **7 mm** from the leading edge for the guides.

For the wire pulleys and guides, drill holes into, but not through, the top surface of the upper wing, as shown on the following illustration.

For the two wire guides drill holes of 0.5 mm diameter.

For the two pulleys drill holes of 0.8 mm diameter.

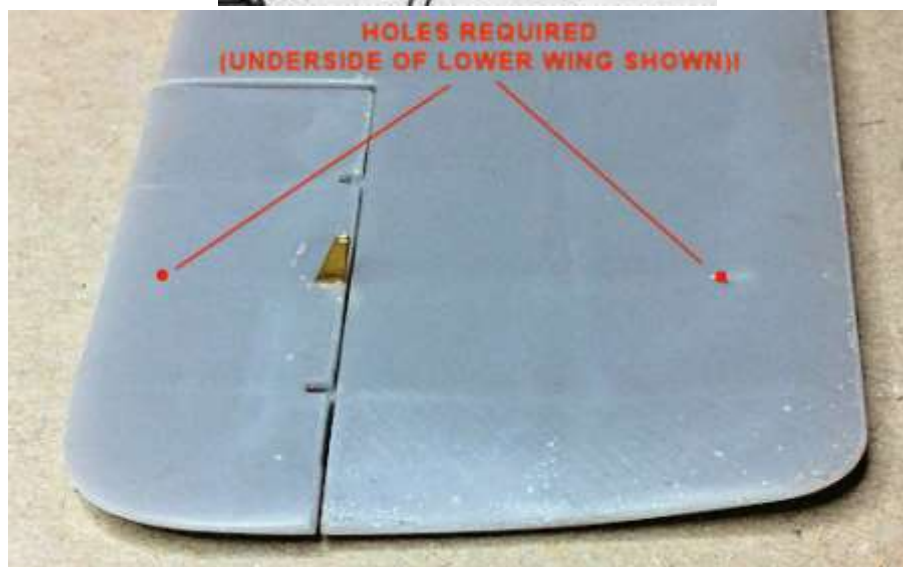
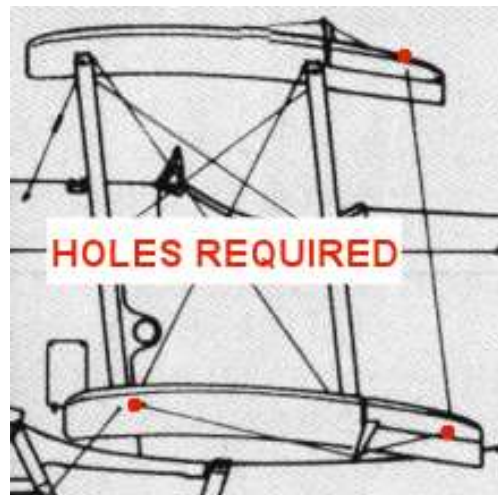
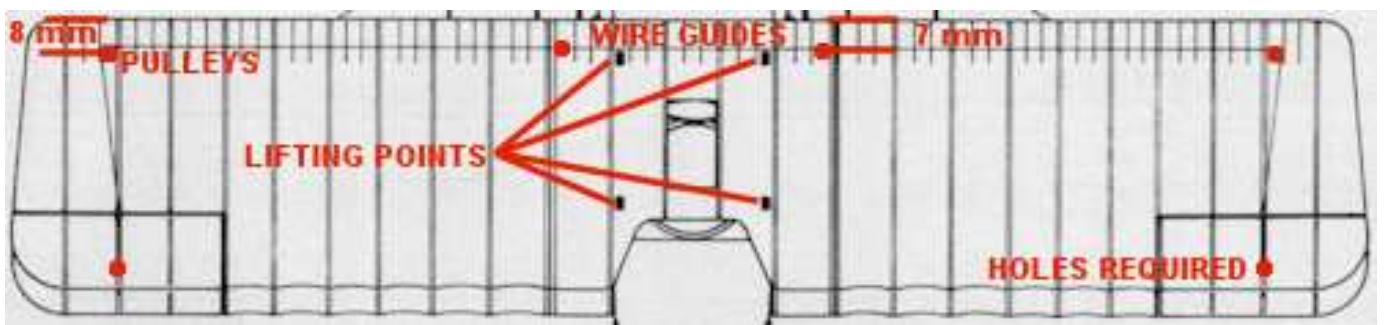

Floats.

The residual resin tree stubs on the bottom surface of all three floats needs to be sanded away. Do not sand away the 'beading' edges around the sides of the floats as they are intentional. Holes of 0.6 mm diameter were drilled into the four strut locations on the tail float. Holes of 0.9 mm diameter were drilled into the top of the two main floats for locating the support struts. Make sure the holes are drilled at the correct angle to mount the 'Z' struts at their correct angles when viewed from the side and front of the floats. Holes of 0.9 mm diameter were drilled into the inner top edges of the two floats for locating the two cross members. Make sure the struts are fitted with the two 'banded' struts towards the front of the floats (above the two closest access panels).

NOTE: *This photograph is **not correct** - the strut should be fitted the other way around.*

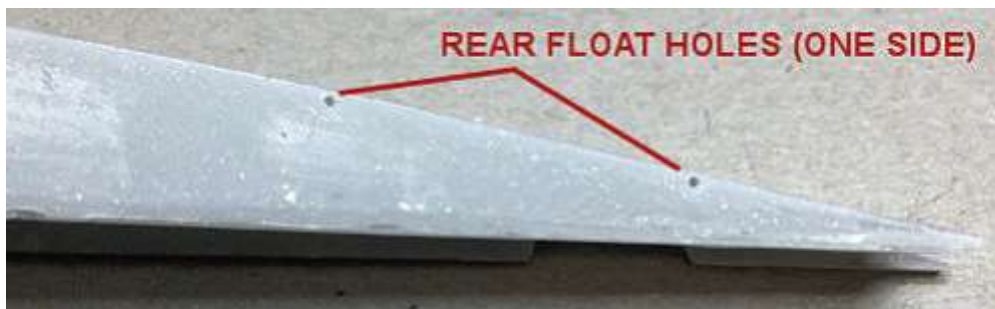
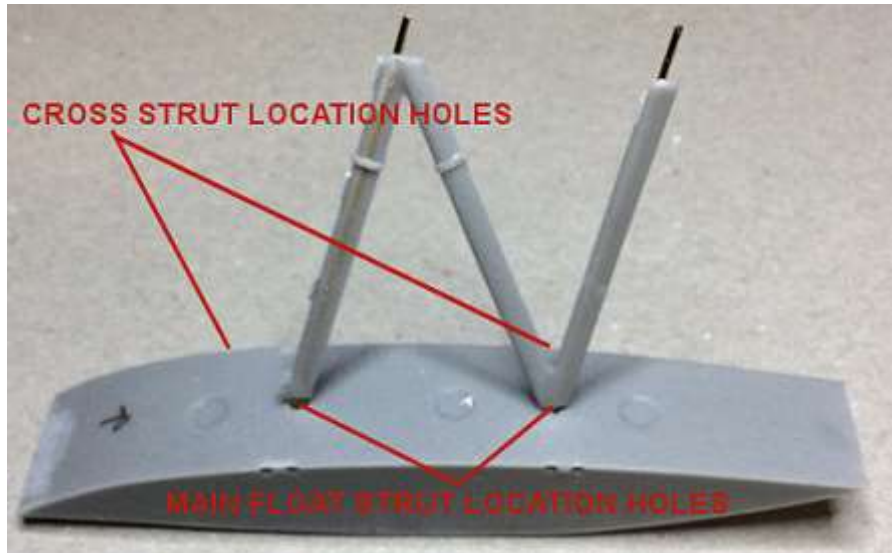

Tail unit.

Tail plane:

The two locating holes in the tail plane need to be drilled out using a 0.9 mm diameter drill, to accept the locating lugs on the bottom of the fin.

Rudder:

NOTE: *The locating lugs on the rear edge of the fin for locating the rudder are weak and not aligned to the holes in the rudder.*

File or sand away the rudder locating lugs from the rear edge of the fin.

Drill two holes of 0.6 mm diameter into the rear edge of the fin where the removed lugs were located.

Cut two short lengths of 0.5 mm rod (e.g. 'Albion Alloy's' or similar).

Secure the two rods into the previously drilled holes in the fin.

Drill two location holes of 0.6 mm diameter into the leading edge of the rudder, to align with the rods in the fin.

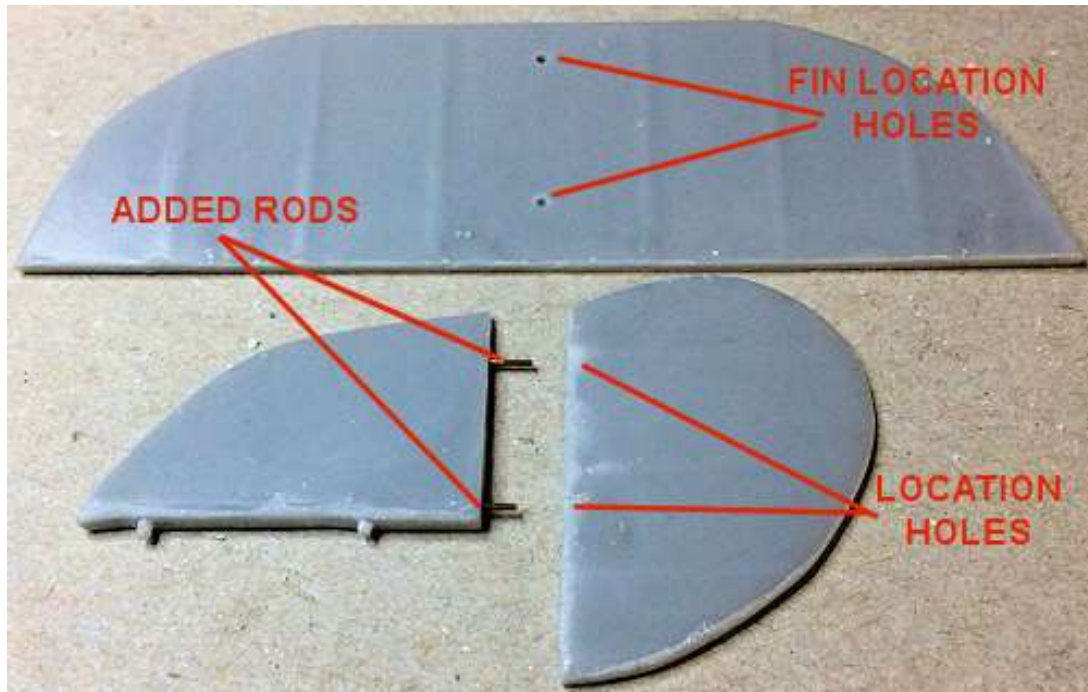

Elevators:

Drill four holes of 0.4 mm diameter into the rear edge of the tail plane.

Cut four short lengths of 0.3 mm tube (e.g. 'Albion Alloy's' MBT03 similar).

Secure the four rods into the previously drilled holes in the tail plane.

Drill two location holes of 0.4 mm diameter into the leading edge of each elevator half, to align with the rods in the tail plane.

Fully locate each elevator half onto its rods in the tail plane.

NOTE: *You may need to file or sand the inboard ends of each elevator half in order to clear the rear of the fuselage when bending them down.*

Carefully bend the elevator halves down slightly and at the same angle.

File or sand the forward edge of the tail plane location lug (on the underside) to allow it to locate better in the fuselage opening, which has a flatter edge than the location lug.

Remove both elevator halves from the tail plane.



Control horns:

Cut out the kit supplied photo-etch control horns (13 x 2 rudder) (14 x 4 elevators).

Drill holes of 0.5 mm diameter through the two elevator halves, close to the leading edge, at the third pre-moulded rib from the outer tip.

Drill a hole of 0.5 mm diameter through the rudder, close to the leading edge, at the second pre-moulded rib from the bottom

At each drilled hole, use a sharp chisel to create a slight cut centrally along each hole (to add a location slot for the control horns).

Secure the four (14) control horns, from each side of the elevator halves, into the pre-drilled holes and slots.

Secure the two (13) control horns, from each side of the rudder, into the pre-drilled holes and slots.

Bracing wire holes:

Drill a hole of 0.3 mm diameter through the rudder at the top rear and at the top of the downward curve.

Drill two holes of 0.3 mm diameter through each side of the tail plane, at the trailing edge and inboard from the outer pre-moulded rib. Drill the holes close together and aligned with the rib.

Control wire holes:

Drill a hole of 0.3 mm diameter through the rudder, aligned to the control horns and at the rear of the rudder.

Drill a hole of 0.3 mm diameter through each elevator half, aligned to the control horns and at the trailing edge of the elevators.

Tail unit components - test fitted



3D printed engine cowl.

NOTE: *The 3D printed engine cowl, once removed from its support trees, is flexible, so care must be taken to not apply too much pressure or the cowl will be damaged.*

Carefully removed the support tree stubs from inside and around the cowl. Test fit the cowl onto the temporarily joined fuselage halves and sand or scrape to achieve a good fit.

Strut locations.

NOTE: *The reinforcing rods through the various struts are close to the resin surface. When working on the struts, take care not to expose the rods or break the resin around them.*

Carefully sand away the residual resin tree stubs from the four wing support struts and the four fuselage cabane struts.

Test fit the integral reinforcing rods into each strut location hole. Make sure the rods locate fully into the holes and trim the length of the rods as necessary to achieve this.

Test fit the four fuselage cabane struts into their fuselage locations. If necessary, carefully cut or scrape the inner faces of strut recesses to achieve a full location of the struts, which should be vertical when viewed from the side and front.

Wings - test fit.

NOTE: *At this stage it is best to test fit the wings, with all struts, to check for correct fit and alignment. Refer to the kit instructions for the 3 degree dihedral angle required for the wings.*

Insert the struts (thin edge to the rear) into their lower wing and fuselage locations. Temporarily hold them in position using 'UHU' White Tack, which doesn't leave an oil residue when removed, as 'Bostik' Blue Tack will.

Temporarily join the two fuselage halves, correctly aligned to each other, using elastic bands.

Fully locate the two lower wings into the fuselage.

Fully locate the two upper wing halves into the wing centre section.

Lay the upper wing assembly top side down and carefully locate the struts of the upturned fuselage assembly into their locations.

Make sure that, taking into account the 3 degree wing dihedral, the assemblies locate correctly (refer to the kit illustrations for guidance).

Disassemble the parts and remove the White Tack.

Aileron control.

NOTE: *The kit supplied control column does not provide for the aileron control cable pulleys (refer to Part 6 (Rigging)). To cut discs from plasticard I use a 'ThinnerLine' circle cutter. There is also a similar tool available from 'DSPIAE'.*

Cut four discs of 3.5 mm diameter from 0.5 mm thick plasticard.

Cut two discs of 2.5 mm diameter from 0.5 mm thick plasticard.

Secure a 3.5 mm disc to the top, forward face of the control column with the centre aligned to that of the pilot's wheel.

Secure a second 3.5 mm disc to the bottom, forward face of the control column and aligned with the disc at the top of the control column.

NOTE: *During the following two steps, apply the styrene cement lightly, to avoid too much build up of cement and melting of the discs.*

Cement a 2.5 mm diameter disc to the centre of the two 3.5 mm diameter discs.

Cement the remaining two 3.5 mm diameter discs, aligned, onto the centre of the 2.5 mm discs, to form basic 'grooved' pulleys.

'Thinnerline' circle cutter



NOTE: *The resin control column is weak and very liable to break away from its cross bar when tension is applied during fitting of the aileron control lines. Therefore the following steps pre-rig the aileron control lines before the control column assembly is fitted to the cockpit.*

Secure the pilot's wheel to the control column.

Cut three long lengths of 'Stroft' 0.08 mm diameter mono-filament.

Secure the centre of the line (in the pulley groove) over the top pulley on the control column.

Route the two lines down to the bottom pulley and cross them (in the pulley groove) so that they leave the pulley on the opposite side.

Apply just enough tension to straighten the lines then secure in position on the bottom pulley.

Roll cut four short lengths of 0.5 mm diameter Aluminium tube ('Albion Alloy's' MAT05 or similar).

Pass the end of one line through a cut tube, the through an eye end of a 1:48th scale turnbuckle ('Gaspatch' resin or metal type C).

Loop the line back and through the tube.

Slide the tube along the lines and up towards the turnbuckle eye end.

Repeat to add a line to the opposite end of the turnbuckle.

Repeat to the opposite aileron line.

Position the inner end of each turnbuckle to approximately 3 mm from the bottom pulley and with the tubes positioned close to, but not touching, the turnbuckles.

Secure the tube to the lines.

Cut away the exposed line tag away from the tubes.

Brush paint the tubes and turnbuckles with 'Mr. Colour' Stainless Steel (213).

Brush paint the centre section of the turnbuckles with 'Tamiya' Hull Red (XF9).



NOTE: *The following steps are required as access to the pilot's seat will be restricted once it is fitted into the cockpit assembly.*

Pilot's seat cushion:

NOTE: *The kit does not supply a cushion for the pilot's seat, so if one is wanted it will need to be made.*

Cover the pilot's seat with kitchen food wrap ('Clingfilm' or similar).

Mix thoroughly an amount of 'Milliput' two part epoxy putty (white) at a 50/50 ratio.

Lightly press the putty onto the seating area, making sure it is no too thick.

Wet a finger or appropriate tools to shape the putty to a cushion.



Leave the putty to fully cure and set.

Once set lift out the cushion and remove the protective wrap.

Check the thickness and fit of the cushion and file or sand as required to achieve the desired look and fit to the seat.

To add texture to the cushion, smear a thin layer of 'Vallejo' Plastic Putty over the seat and texture the surface as required.

Leave the putty to fully set.

NOTE: *The kit supplied photo-etch seat belts were replaced with those from a spare 'Wingnut Wings' Sopwith F.1 Camel kit, as they are better detailed.*

Anneal (soften) the photo-etch seat belts over a flame (e.g. cigarette lighter). Take care not to melt the thinner parts.

Temporarily attached the two seat support cross member to the underside of the seat, using 'UHU' White Tack or tape.

Slide the seat belt retaining loops over the ends of the rear seat support cross member.

Carefully bend the two seat belts over the seat sides and onto the seat cushion, to create a realistic position for the belts.

Carefully remove the two seat belts, without distorting the created shapes.

Detach the two seat support cross member from the underside of the seat.

Filler cap and hinge.

NOTE: *From drawings and some photographs, it appears the Ansaldo 'Baby' had a filler cap (possibly oil tank) located in the forward, top, left side access panel. Also a central hinge was located between the forward, top, left and right side access panels. Neither the cap or the hinge are supplied or moulded on the kit parts.*



Panel hinge:

Cut two lengths of 'Aviatic' WW1 short spaced rib stitching (ATTETCH 001), to span between the front edge of the fuselage and the rear edge of the access panels.

Secure both strips together and centrally on the panels.

Filler cap:

Using a circle cutter (e.g. 'Thinnerline cutter' or similar), cut two discs from 0.2 mm thick plastic card - 3 mm and 2 mm diameter.

Secure the 3 mm diameter disc in position (refer to above illustration).

Secure the 2 mm diameter disc in position, centrally on the 3 mm disc.

Cut a short length of 0.3 mm tube ('Albion Alloy's MBT03 or similar) and secure in position across the centre of the 2 mm diameter disc.



Wing root rigging points:

NOTE: From drawings and some photographs, it appears the Ansaldo 'Baby' had a rigging apertures at the base of the fuselage sides, above the wing roots. These were for the two flying wires on each side of the aircraft. They are not supplied or moulded on the kit parts.

Cut four of the rectangular rigging apertures from the 'PART' 1/48th scale WWI Aircraft Control Horns (S48-087).

Secure them in position (two each side of the fuselage) as shown on the following photograph.

Linen creases:



NOTE: To gain access into the fuselage, the right side of the fuselage had a linen panel stitched from the rear of the fuselage joint to the rear of the tail float. Often the corners of stitched linen panels were creased, due to the tension imparted when stitching the panel. I chose to represent these creases using 'AV' Masilla Plastica (401) putty.

Place a small amount of 'AV' Masilla Plastica (401) putty (or similar modelling putty) into the four corners of the stitched panel of the right side of the fuselage.

Use a suitable, round ended tool, such as a paper embossing tool, create ridges (creases) radiating from the corners of the applied stitching.

Once dry, gently sand the creases to remove any sharp or raised edges and to blend them to the fuselage.



Other enhancements.

Other model corrections or enhancements will be added at the appropriate stage, later in the build (Part 12 Fuselage and 13 Construction).

PART 12

FUSELAGE

PART 12 - FUSELAGE

This part of the build log covers the construction of the fuselage, including the cockpit.

NOTE 1: *As this model is resin, all assembly of parts must be done using CA adhesive.*

NOTE 2: *Unless otherwise stated, follow the 'Lukgraph' instructions for assembly of the parts.*

Cockpit.

As I was unable to find any confirmation of the internal cockpit detail for the Sopwith 'Baby' aircraft, the following additional enhancements are based on typical cockpits of the time.

Rudder control cables.

Elevator control cables.

Aileron control cables.

Cockpit side frame bracing cables.

Cockpit floor bracing cables.

Throttle control rod.

Fuel tank delivery pipe.

Part errors:

1. The kit instructions show that there are five cross members to be fitted between the two cockpit side frames. However the kit only supplies four cross members and their lengths don't seem to align with those shown on the illustration. Therefore cross members may have to be made as replacements.
2. The rectangular openings at the top of the forward bulk head are not as shown on the kit illustrations.

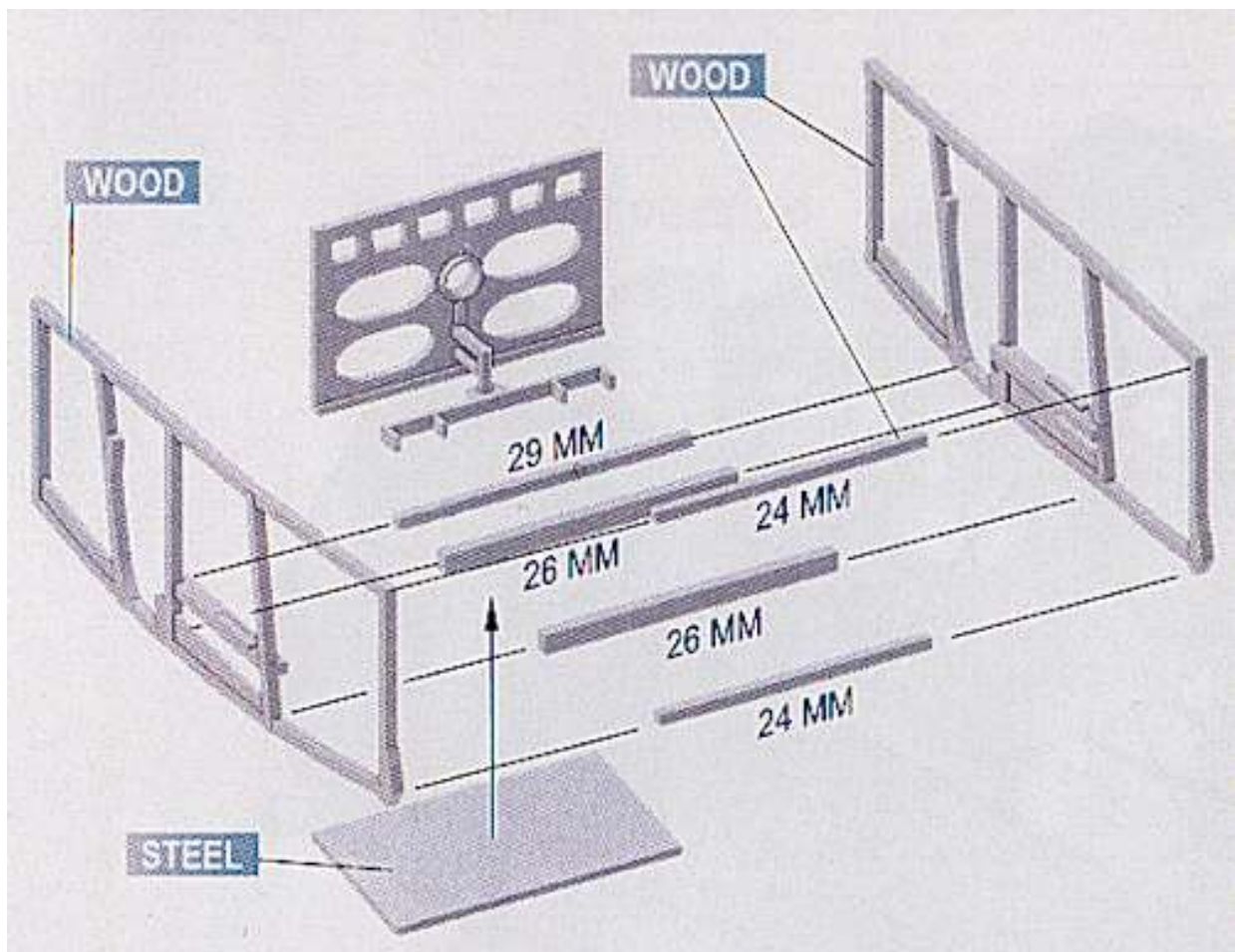

3. The cockpit left side frame is missing the instrument panel location stub.



Preparation:

Carefully remove all of the required cockpit components from their resin support trees.

Carefully file or sand away any residual tree stubs from the various components.

NOTE: *The kit supplied photo-etch seat belts were replaced with those from a spare 'Wingnut Wings' Sopwith 'Snipe' kit, as they are better detailed.*

Remove the instrument panel, throttle lever and seat belts from the supplied photo-etch sheets.

Carefully file or sand away any residual tags from the photo-etch parts.

To locate components fully, drill holes of 1.2 mm diameter through the cockpit parts as shown on the following illustration.

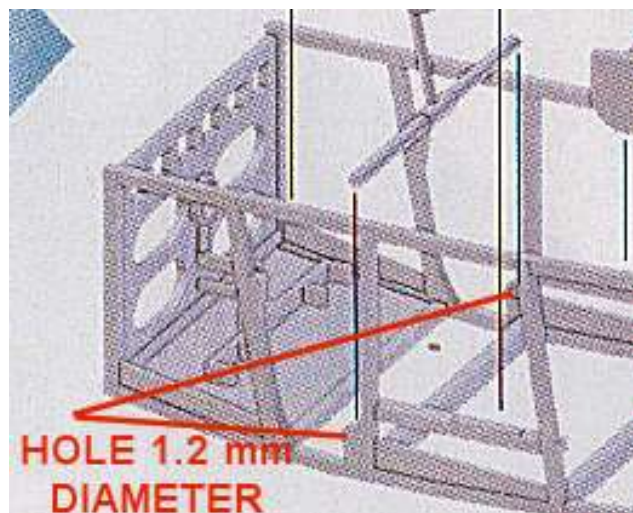

NOTE: *The following step marks the inner surface of the fuselage halves as a guide for future painting and weathering.*

Lay the cockpit side frames in position in their fuselage half and lightly scribe the outline of the frames onto the fuselage inner surface.

Airbrush the cockpit components and inside both fuselage halves with a grey primer (e.g. 'AK Interactive Grey (AK-758) or similar).

Airbrush the following parts with 'Tamiya' Wooden Deck Tan (XF78) or Dark Yellow (XF60), suitably thinned with 'Tamiya' Thinners (X20A):

Cockpit side frames, forward bulkhead and floor panel, rudder bar and attachment, pilot's seat, all cockpit frame cross members, photo-etch instrument panel and false floor on the fuselage half.

Airbrush the following parts with 'Alclad' Steel (ALC-112) or similar:

Control column and cross bar, control column torsion bar, elevator bell crank and rear cross bar, centre spokes of the pilot's wheel and the fuel tank.

Airbrush the inner sides of the two fuselage halves (not the false floor) with 'Tamiya' Buff (XF57) or similar.

Brush paint the hand grip around the pilot's wheel with 'Tamiya' Buff (XF57) or similar.

Brush paint the pipe connection under the fuel tank 'Mr. Colour' Brass (219) or similar.

NOTE: For the following step I used 'DecoArt Crafters Acrylic' (water based) acrylic paints (Burnt Umber).

Refer to Part 3 (Wood Effects) of this build log and apply your desired wood effects to the following parts:

Cockpit side frames, forward bulkhead floor panel and rudder bar, pilot's seat, all cockpit frame cross members, photo-etch instrument panel and false floor on the fuselage half.

Brush paint the following parts with 'Mr. Colour' Stainless Steel (213) or similar:

Rudder bar forward bulk head attachment, forward bulk head (not the floor panel/rudder bar) and inside the fuselage halves at the forward side frame area (using the previously marked side frame outlines as a guide).

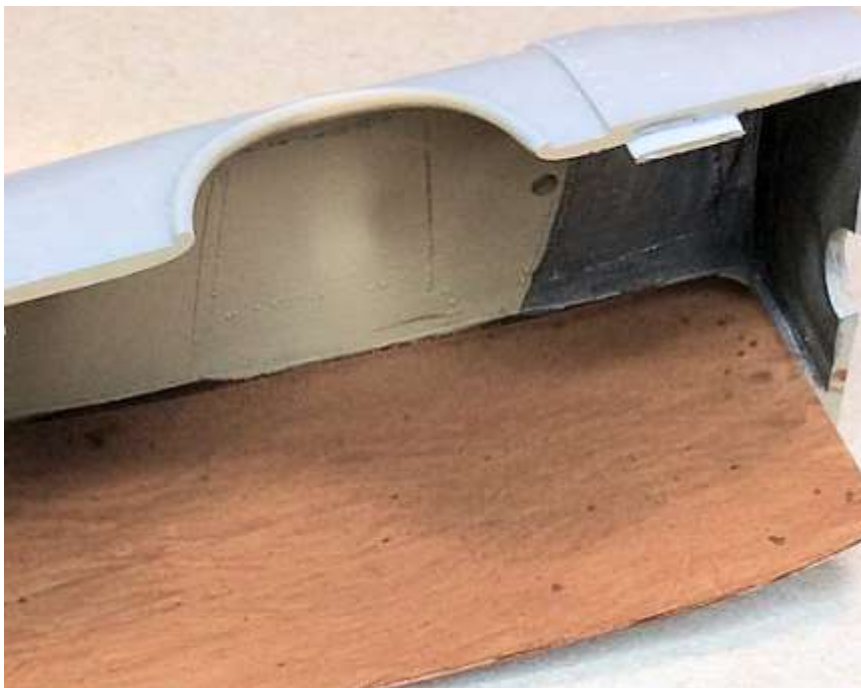

NOTE: The peel off 'foil' instrument panel supplied in the kit is self adhesive and has a strong bond to the surface. Care must be taken when applying as it will not move once applied. A spare panel is provided.

Peel off a 'foil' instrument panel from the kit supplied sheet.

Trim away any edges that overlap the resin panel.

Position the photo-etch instrument panel onto the applied 'foil' panel and hold in position.

Carefully apply thin CA adhesive around the edges of the assembly to bond the resin, 'foil' and photo-etch together.

Using a sharp, curved scalpel blade, carefully and gently scrape away the applied paint from around each instrument bezel, switch positions and the raised detail.



Once dry, airbrush several light coats of gloss clear (e.g. 'Alclad' Aqua Gloss (ALC -600), 'Tamiya' Gloss clear (X22) or similar) over the instrument panel.

Drill a hole of 0.5 mm diameter through the five exposed photo-etch switch positions.

Roll cut five lengths of 0.4 mm diameter Nickel-Silver tube (e.g. 'Albion Alloy's' NST04 or similar).

Bend one end of each tube to 90 degrees then flatten that end using flat nosed pliers.

Secure each 'switch lever' into a hole at the switch positions.

Brush paint each 'switch lever' with 'Mr. Colour' Stainless Steel (213) or similar.

If possible, use appropriate decals from your spares to add to locations on the instrument panel.

Use 'Microscale' MicroSol or similar setting solution to conform the decals onto the instrument panel.

Brush 'Tamiya' Gloss clear (X22) or similar over the instrument faces.

Once dry, airbrush several light coats of semi-matte clear (e.g. 'Alclad' Light Sheen (ALC -311), 'Tamiya' Semi-clear (X35) or similar) over all cockpit parts.



Apply 'Mig' Oil Brusher (3514-Earth) around the side frame outlines previously marked on the inside of each fuselage side.



Using 'Mig' Odourless Thinners (2019), brush away the oil paint to create linen staining around the side frames (when fitted).



Rigging side frames:

NOTE: *Cross bracing wires would have been fitted between each of the four bays in cockpit side frames.*

Drill a hole of 0.3 mm diameter at angle through the corners of each bay in the cockpit side frames.

Create a cross bracing wire as follows:

Cut two lengths of 'Stroff' 0.08 mm diameter mono-filament.

Roll cut four short lengths of 0.5 mm diameter Aluminium tube ('Albion Alloy's' MAT05 or similar).

Pass a line through a cut tube, the through an eye end of a 1:48th scale turnbuckle ('Gaspatch' resin or metal type C).

Loop the line back and through the tube.

Slide the tube along the lines and up to, but not touching, the turnbuckle eye end.

Secure the tube to the lines.

Cut away the exposed line tag away from the tube.

Repeat to add a line to the opposite end of the turnbuckle.

Pass each line through a cut tube.

Pass the lines through the diagonally opposite pre-drilled holes in a bay of a cockpit side frame.

Position the turnbuckle close to the top corner of the frame bay and secure.

Pull the other end of the line taut and secure.

Cut away the exposed line outside of the frame.

Repeat the procedure to add cross bracing lines to all four bays of both cockpit side frames.

Brush paint the tubes and turnbuckles with 'Mr. Colour' Stainless Steel (213).

Brush paint the centre section of the turnbuckles with 'Tamiya' Hull Red (XF9).

NOTE: *During the following steps, make sure any paint. Primer is removed from the mating faces of the parts to be assembled.*

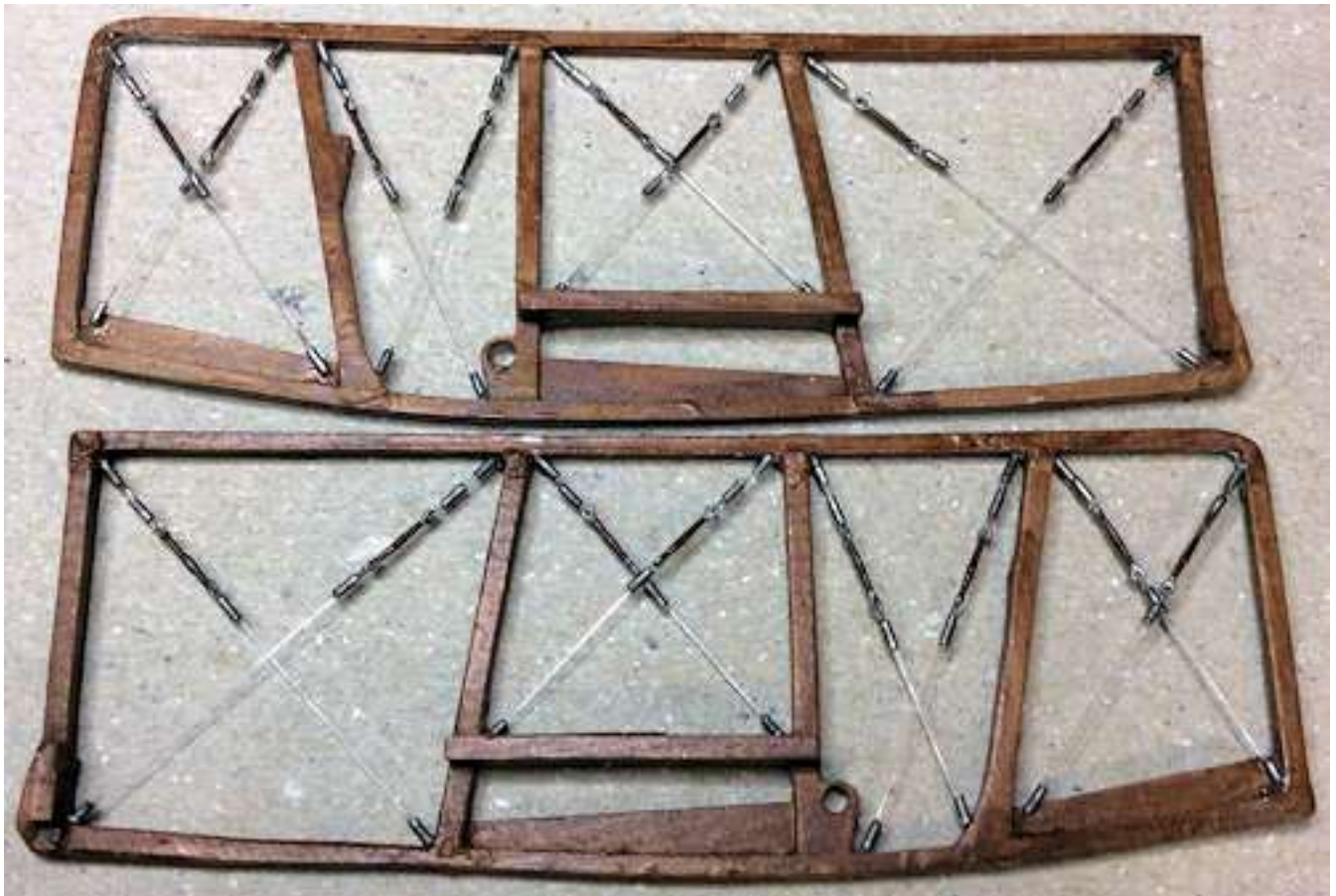

Secure the fuel tank, control column and cross bar assembly and the two rear and two bottom cross members to assemble the basic frame.

Once assembled, test fit the frame assembly into the left fuselage half the carefully locate the right fuselage half.

Make sure the cockpit frame assembly locates correctly inside the fuselage and that there are no gaps in the fuselage seam joints.

NOTE: *If gaps are seen, it is probably caused by cross members being too long. Note where reduction is required then separate the fuselage halves. Cut through the relevant cross member joint at the side frame and cut off a small amount from that end. Re-attach the cross member to the side frame and repeat the fit to fuselage check until a good fit is achieved with no gaps in the fuselage seam joint.*



Drill a hole of 0.3 mm diameter through each end of the elevator bell crank.

Drill a hole of 0.3 mm diameter through each side of the rudder bar, inboard from the inner foot blocks.

Locate the front bulk head/floor assembly in position on the front of the frame assembly and secure in position.

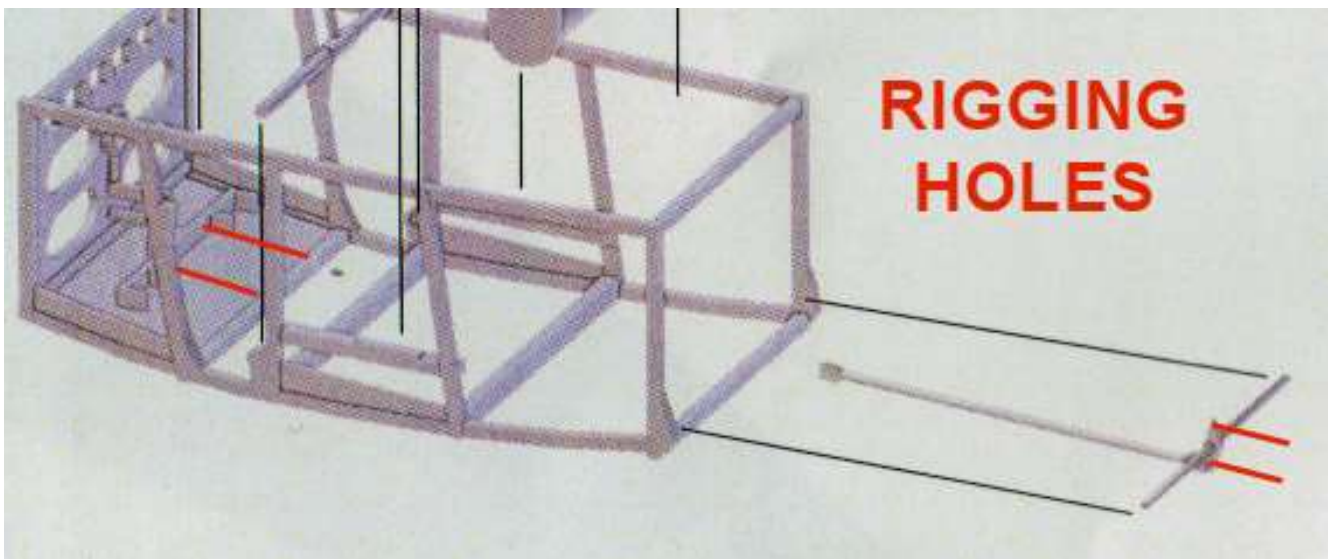

Secure the cross member to the front edge of the forward floor.

Slide the elevator bell crank onto its cross bar, but **do not** secure in position.

Locate the cross bar in position on the top of the blocks at the rear of the frame assembly and secure in position, at each end.

Secure one end of the elevator control rod at the centre, base of the control column.

Position the elevator bell crank on its bar so that fork at the rear end of the elevator control rod will locate around one end of the elevator bell crank.

Secure the elevator control rod and bell crank in position.

Secure the two support cross members for the pilot's seat in position across the rear and centre of the side supports on the cockpit frames.

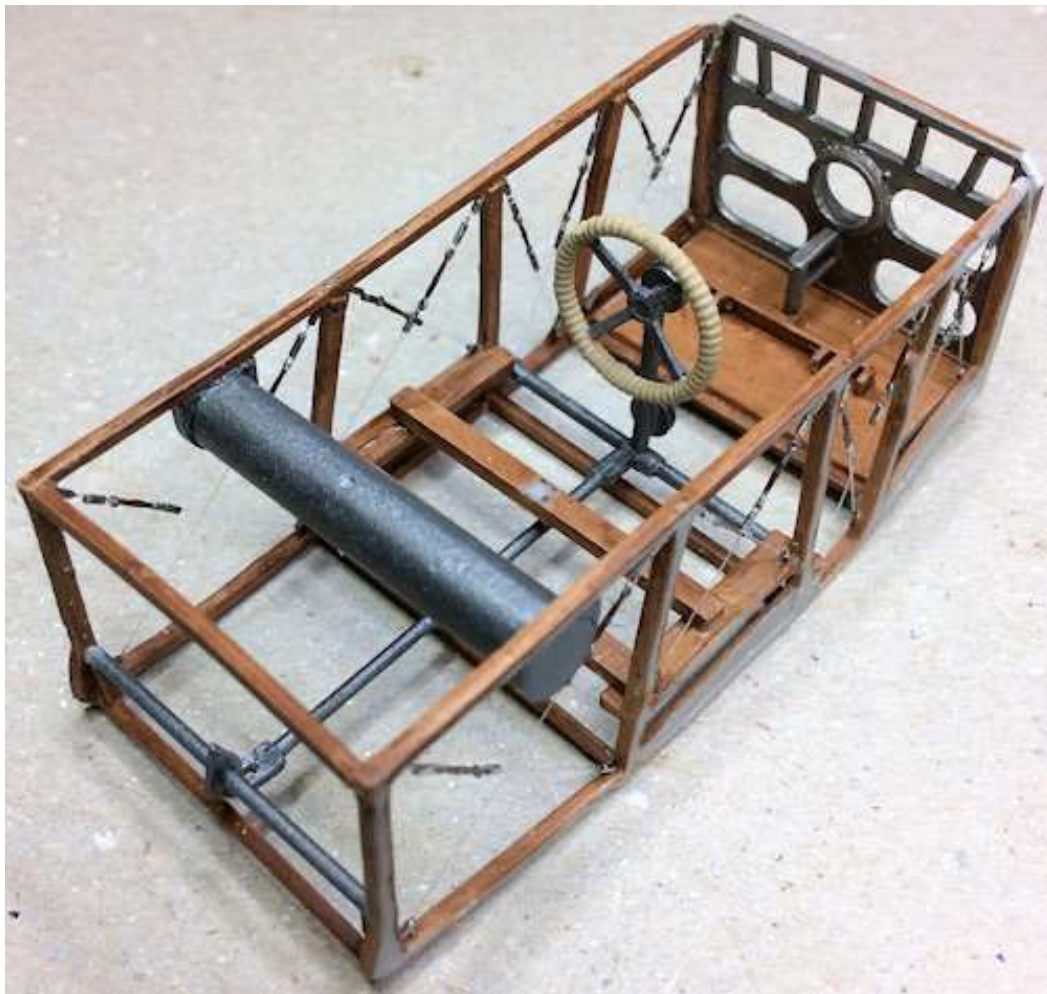

NOTE: *I found that the photo-etch instrument panel, when fitted, overlaps the edges of the resin panel. Therefore trimming of the edges of the photo-etch panel may be required to achieve a good fit inside the fuselage.*

Position the instrument panel assembly over the side frames and onto its locations on the side struts. If necessary carefully file or sand its edges to achieve an easy location between the side frames.

Locate the cockpit frame assembly into the fuselage half then locate the other fuselage half to join them together.

Make sure the fuselage halves join fully without being forced. If so, note where the instrument panel is interfering with the fit, separate the fuselage halves and file or sand where required. Repeat the fit check until a good fit is achieved with no gaps in the fuselage seam joints.

Secure the instrument panel assembly onto the cockpit frame.

Re-check the cockpit frame fit inside the fuselage.

Brush 'Tamiya' Clear (X22) onto the instruments faces.

Brush 'AK Interactive' Kerosene (AK 2039) thinned with white spirit, over the hand grip of the pilot's wheel.

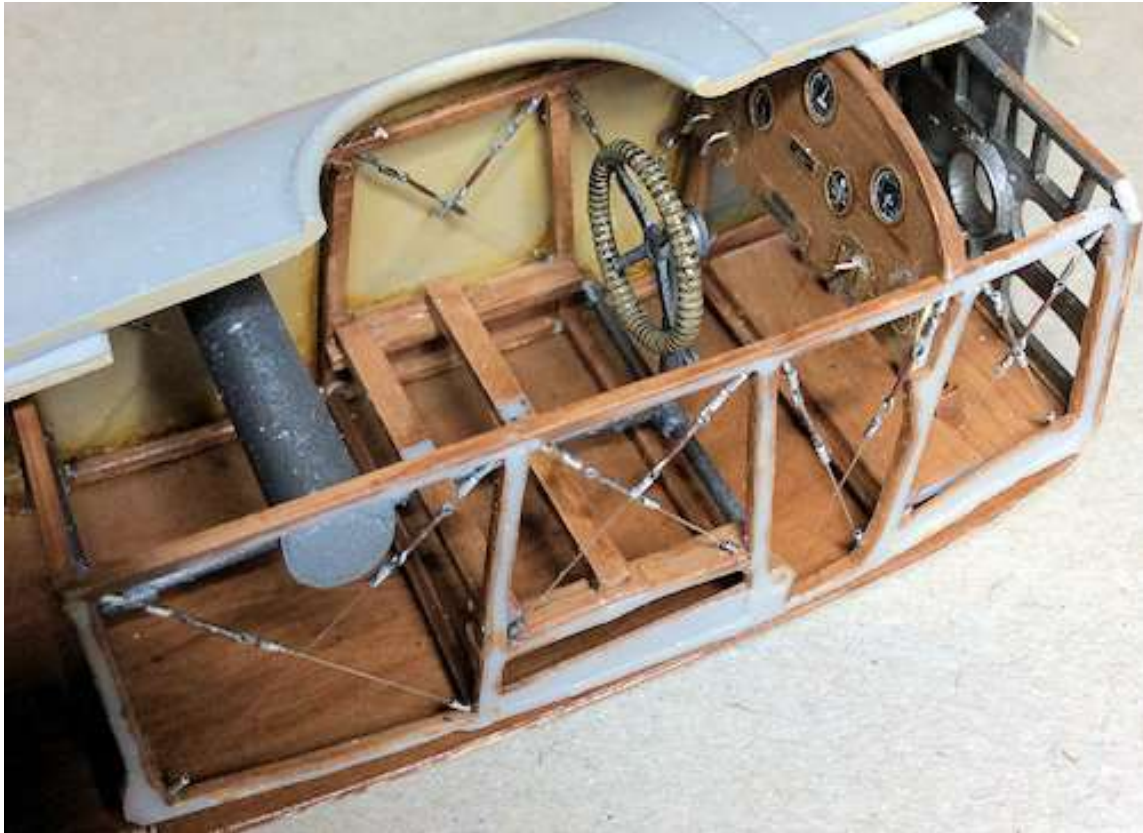

Rudder controls:

NOTE: *Once the cockpit assembly is fitted inside the closed up fuselage, very little, if anything, can be seen of the rudder and elevator control lines at the rear of the cockpit. Therefore I chose not to go any past the rear of the cockpit assembly with any control lines.*

Cut two long lengths of 'Stroff' 0.08 mm diameter mono-filament.

Roll cut four short lengths of 0.5 mm diameter Aluminium tube ('Albion Alloy's' MAT05 or similar).

Pass a line through a cut tube, the through an eye end of a 1:48th scale turnbuckle ('Gaspach' resin or metal type C).

Loop the line back and through the tube.

Slide the tube along the lines and up to, but not touching, the turnbuckle eye end.

Repeat this procedure to add a line to the other end of the turnbuckle.

Repeat to create a second line with turnbuckle.

Brush paint the tubes and turnbuckles with 'Mr. Colour' Stainless Steel (213).

Brush paint the centre section of the turnbuckles with 'Tamiya' Hull Red (XF9).

Pass one end of line through the pre-drilled hole in one side of the rudder bar.

Repeat to add the control line to the other side of the rudder bar.

From the front side of the rudder bar, pull each line so the tube on the line is in contact with the rudder bar.

Secure the lines in position.

Pass the other lines back under the cross member supports for the pilot's seat and over the elevator cross bar at the rear of the cockpit assembly.

Gently pull the each line taut over the elevator cross bar, keeping the lines parallel to each other and aligned with the ends at the rudder bar.

Secure the lines in position over the cross bar.

Cut away any exposed line from the front of the rudder bar and elevator cross bar.

Aileron controls:

NOTE: *The aileron control lines were added during the preparation of the control column assembly.*

Route the two aileron control lines outboard and over the cockpit side frames where the cross bar locates.

Carefully pull the lines taut and secure them to the cockpit side frames.

Cut away excess line outside the cockpit side frames.



Throttle control:

Bend the strut lags and throttle lever on the photo-etch throttle.

Brush paint the throttle lever with 'Mr. Colour' Stainless Steel (213) or similar.

Locate the throttle onto the right cockpit frame and secure in position.

Cut an appropriate length of 0.4 mm diameter Nickel-Silver tube, such as ('Albion Alloy's NST04 or similar.

Position the tube against the bottom of the throttle lever and the bottom edge of the instrument panel.

Secure the tube in position.



Fuel tank pipe:

Cut a long length of 0.5 mm diameter tinned copper wire.

Anneal (soften) the wire over a flame (e.g. cigarette lighter).

Bend one end of the wire to 90 degrees.

Position the wire against the cockpit side frame and trim the length just beyond the bottom edge of the instrument panel and the bent end so it touches the fuel tank connection.

Secure the wire in position.

Using 'Tamiya' Rubber Black (XF85) or similar, brush paint a thin line over the wire where it passes over at the cockpit side frame uprights (to represent pipe clamps).

Using 'Mr. Colour' Brass (219) or similar, brush around the wire where it touches the fuel tank connector (to represent a pipe connector).

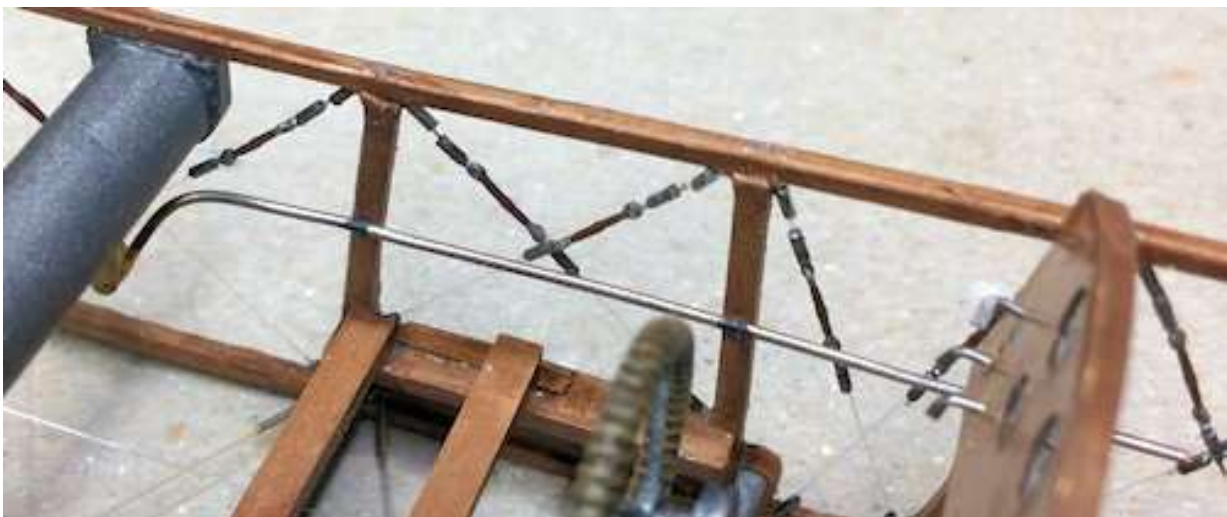

Floor cross bracing:

Drill holes of 0.3 mm diameter through the bottom of the two cockpit side frames at the corners of each bay.

Cut two long lengths of 'Steelon' 0.12 mm diameter mono-filament (or similar).

Pass the end of one line through the pre-drilled holes at the rear of one of the cockpit side frames.

Secure the line in position.

Slide two 0.4 mm diameter Nickel-Silver tube ('Albion Alloy's' NST04 or similar) onto the free end of the line.

Pass the free end of the line diagonally through the pre-drilled hole on the opposite cockpit side frame.

Pass the free end of the line through the adjacent pre-drilled hole.

Slide two 0.4 mm diameter Nickel-Silver tube ('Albion Alloy's' NST04 or similar) onto the free end of the line.

Continue as above to add the cross bracing line and tubes to the three bays.

Make sure the lines are taut then secure the free end of the line to the relevant corner at the front, underside of the forward floor panel.

Slide each tube against the relevant cockpit side frame and secure in position.

Repeat the procedure to add the cross bracing line from the opposite cockpit side frame.

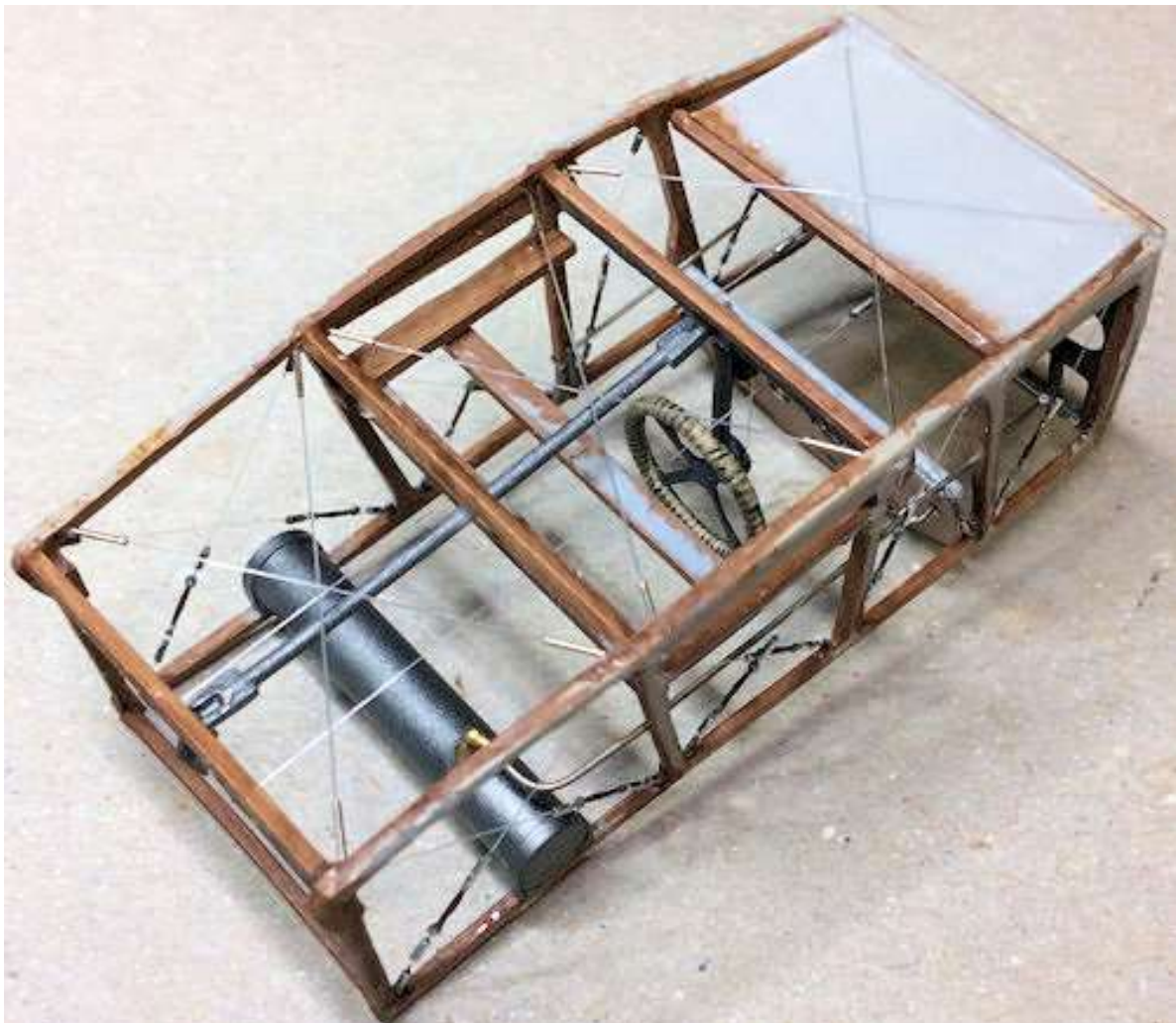

Pilot's seat:

Prime the 'Milliput' seat cushion and the two seat belts using 'AK Interactive' Primer and Micro-Filler (Grey AK758) or similar.

Brush paint the seat cushion with a mix of 'Tamiya' Hull Red (XF9) and Humbrol Leather (62).

Secure the seat cushion onto the pilot's seat.

NOTE: *When painting, try not to flex the photo-etch seat belts from their pre-formed shapes.*

Brush paint the seat belts as follows:

Belts overall - 'Tamiya' Dark Yellow (XF60).

Fastening belt - 'Tamiya' NATO Brown (XF68) and Hull Red (XF9) at 3/1 ration.

Metal fittings - 'Mr. Colour' Stainless Steel (213).

Carefully open up the belt end loops.

Position the pre-formed belts over the edges of the seat and onto the seat cushion.

Secure the two belts in position.

Position the pilot's seat on the cross member support struts, with the two belts loops over the rear seat support cross member.

Secure the seat to the two seat support cross members.

Cut as required as wrap the belt loops around the support strut.

Weathering:

Brush 'AK Interactive' Kerosene (AK-2039) thinned with white spirit, over the seat belts, fuel tank and at the rudder foot guides on the forward floor board.

Finish:

Airbrush a light coat of semi-matte sealer (e.g. 'Alclad Light Sheen ALC-311', 'Tamiya' Semi-Gloss (X35) or similar) over the cockpit assembly.

If necessary, brush 'Tamiya' Gloss (X22) onto the instrument faces.

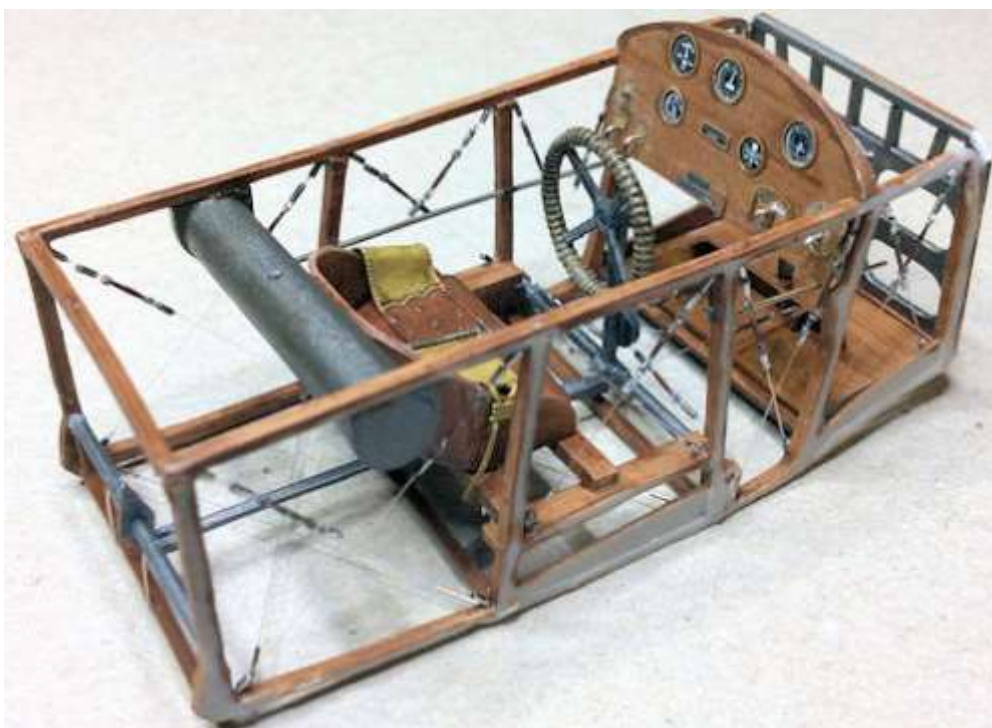

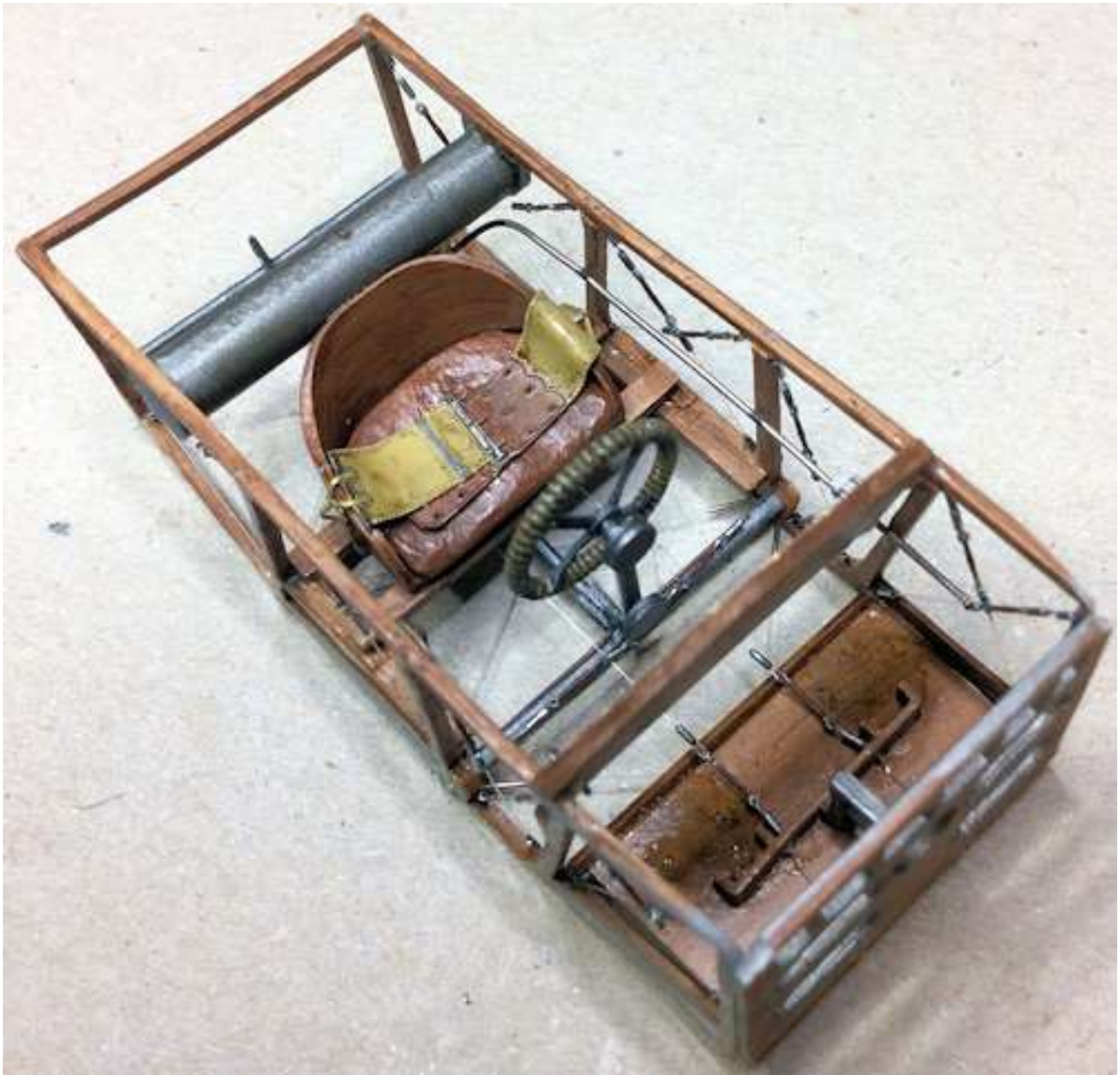
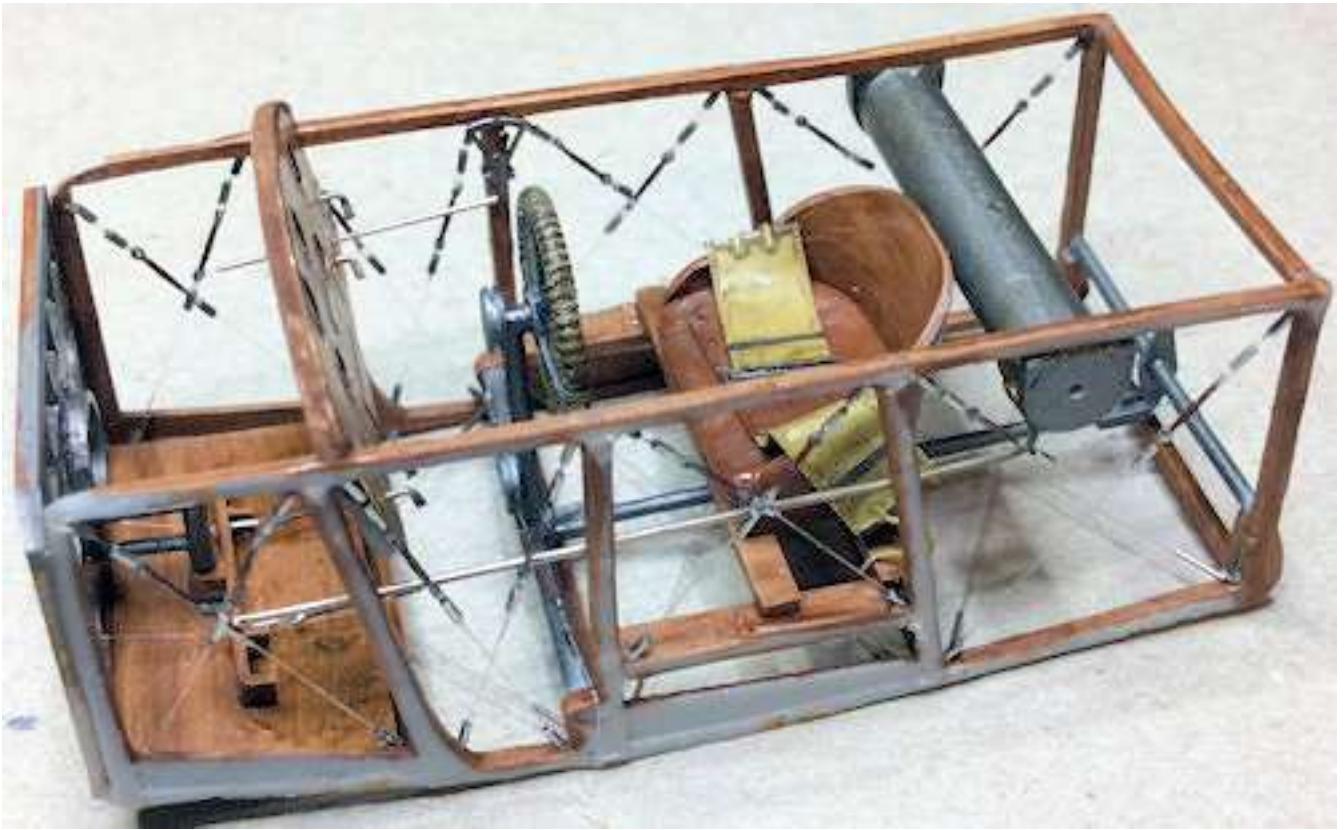



Fuselage closing:

NOTE: *It is not necessary to secure the cockpit assembly into the fuselage halves, as the rear location blocks on the fuselage halves should prevent any movement.*

Fully locate the cockpit assembly into the fuselage half that has the false floor.

Locate the two fuselage halves together on the added location rods and plastic card tabs, but do not fully close them together.

Apply thin CA adhesive to the locating rods and plastic card tabs.

Push the fuselage halves fully together, making sure there are no gaps around the seam joint.

Hold until the adhesive sets.

NOTE: *Due to the fuselage sides being thin, they are liable to flex if too much pressure is applied, such as when being held.. From this stage in the build, handle the fuselage with care.*

Apply thin CA adhesive along all of the fuselage seam joints, to complete adhesion of the seam joint.

Once the adhesive has set, sand across the fuselage seam joint to remove residual adhesive and to remove any steps to blend the joint.

Apply a model putty, such as 'De-Lux Materials' Perfect Plastic Putty or similar, along the fuselage seam joints to fill any recesses.

Leave the applied putty to fully set (overnight).

Once the modelling putty has fully set, sand across the fuselage seam joints to achieve a gap free joint.

Check to fuselage seam joint for any remaining gaps or steps. If found sand the flush and if necessary apply either more modelling putty or if the anomalies are slight, a thick surface primer such as 'Mr. Surfacer 500'.

Once fully set sand again until a smooth, gap and step free seam joint is achieved.



NOTE: *The pre-moulded fuselage stitching was removed during the preparation stage (Part 11) of this build and will be replaced using photo-etch stitching from the 'Eduard' WW1 Stitching (EDP32228) set.*

Remove a strip of fuselage stitching from the photo-etch sheet.

Cut to length and secure in position the forward vertical strip on the right side of the fuselage.

Cut to length and secure in position the rear vertical strip on the right side of the fuselage.

Cut to length and secure in position the horizontal strip between the two vertical strips on the right side of the fuselage.



Panel lines:

NOTE: *The fuselage rear section of this aircraft was designed to be detached for storage of ships. The joint was located at the rear edge of the cockpit decking panel behind the cockpit and was secured by turnbuckle fasteners at each of the four corners.*

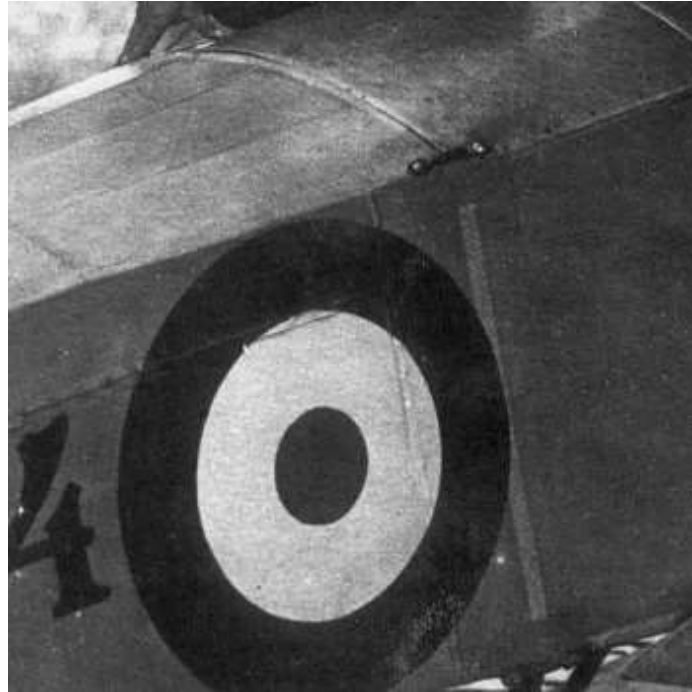

Scribe the fuselage joint across the top and bottom faces of the fuselage and down the left side of the fuselage.

Scribe the panel line across the top of the fuselage at the rear of the cockpit opening.

Scribe the front and rear lines of the plywood 'walk way' panels on the top of each lower wing root.



Painting - CDL (linen):

Cover or mask off the open cockpit, the hole in the engine bulk head, the opening for the tail plane and the two carburettor air intakes (toothpicks).

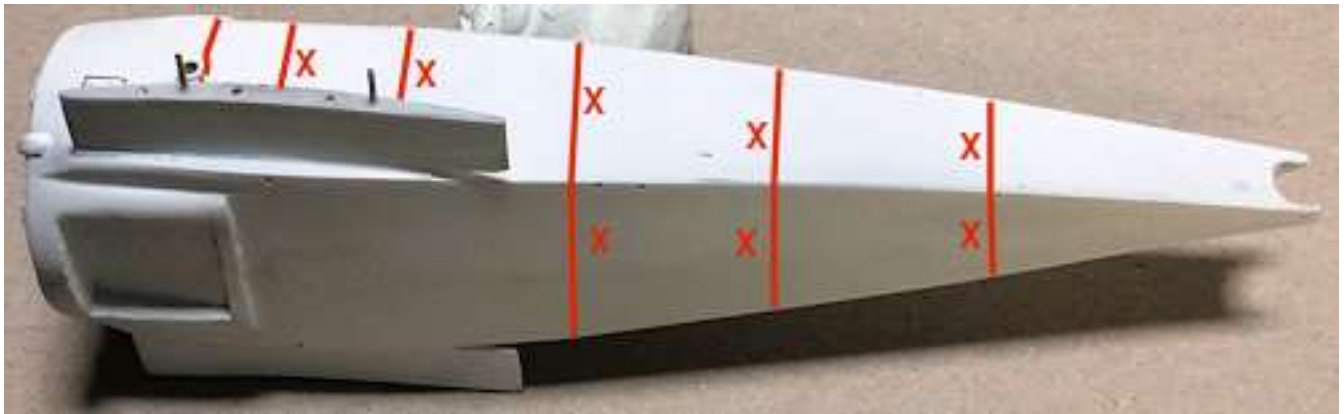

NOTE: Avoid as much as possible, overspray of the paint to the areas marked in 'blue', as these will require either a wood or metal finish. If necessary, mask off these areas. For edges that can't be masked easily, apply 'Humbrol' Maskol or similar.



Prime to worked areas with a white primer, such as 'AK Interactive' White (AK759) or similar. When dry any remaining joint anomalies will easily be seen and if necessary can be re-filled, sanded and re-primed until a gap free finish is achieved.



NOTE: It was common for the edges of structural frames and ribs to visible through the linen covering of the fuselage or wings etc, as can be seen in the following photograph of the fuselage side of the cockpit. Where not actually moulded on the model parts, this can be represented by applying 'pre-shading' to the model surfaces.



The following pre-shading needs to be applied only to areas covered by linen. Other areas with either a wood or metal finish will be treated separately.

Apply strips of 1 mm wide masking tape to the sides, top and underside of the fuselage at the lines marked 'X' (15 in total). The remaining marked lines do not require masking.



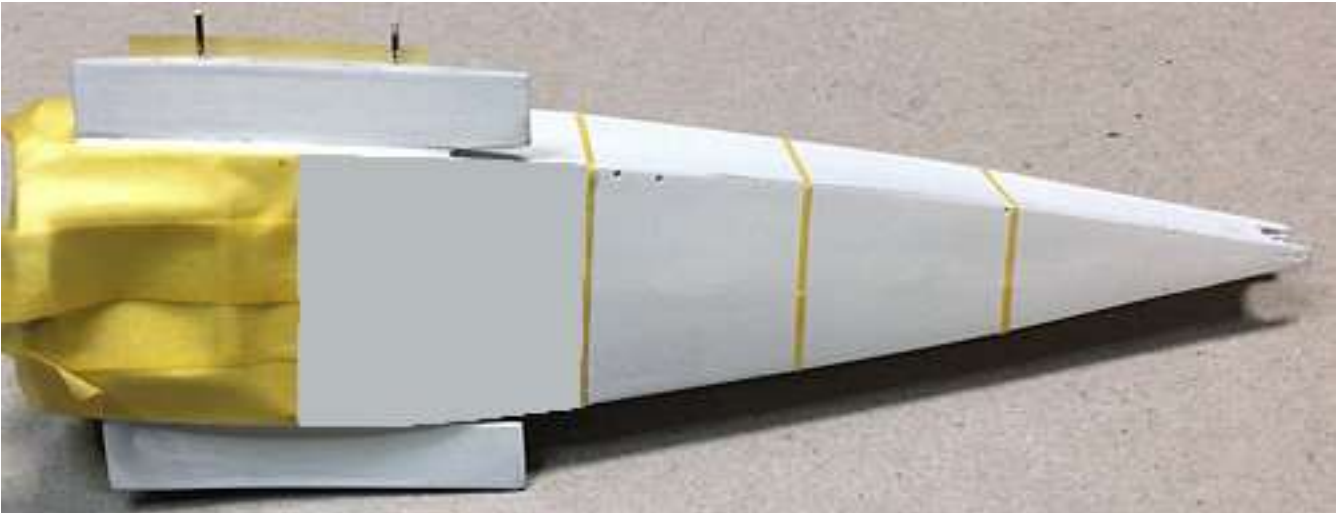

Airbrush 'Tamiya' Smoke (X19) slightly thinned with X20A, around all marked 'red' lines on the previous photograph (masked or not), to create light pre-shading on around the lines. Also around the corners of each 'frame bay' and fuselage edges.

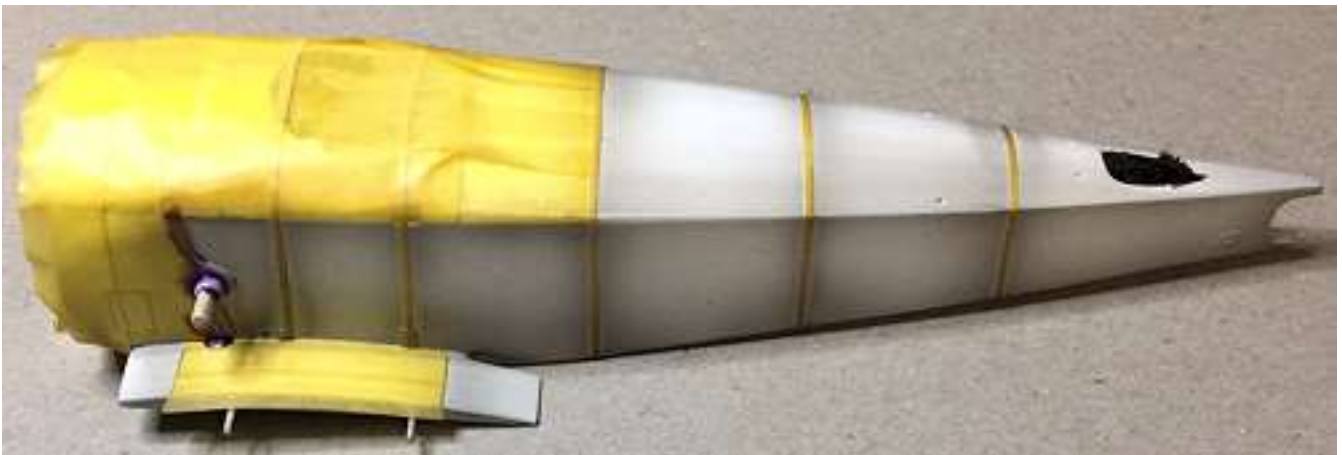

NOTE: During the following step airbrush light coats of the paint, allowing time for the drying effect to take place between coats. The intention is to fade back the pre-shading slightly (not fully cover).

Lightly airbrush 'Tamiya' Wood Deck Tan (XF78) mixed with Buff (XF57) to 2:1 ration and thinned with X20A, over the fuselage.

Once the pre-shading has been faded slightly, but not totally covered, remove all of the 1.0 mm wide masking strips.

NOTE: During the following step airbrush light coats of the paint, allowing time for the drying effect to take place between coats. **The intention is to further fade back the pre-shading and the to blend in the unmasked strips.**

Lightly airbrush 'Tamiya' Wood Deck Tan (XF78) mixed with Buff (XF57) to 2:1 ration and thinned with X20A, over the fuselage.

Once the desired effect is achieved, remove all masking and the applied covering or masking from the open cockpit, the hole in the engine bulk head, the opening for the tail plane and the two carburettor air intakes (toothpicks).

NOTE: Although faded, the pre-shading will darken slightly when the gloss sealing coat is applied prior to applying the 'Aviatic' linen decals.



Preparation - wood effect:

Cover or mask the open cockpit, the hole in the engine bulk head, the two carburettor air intakes (toothpicks) and all of the model **except for the areas marked 'red'** in the following photograph.



Airbrush 'Tamiya' Buff (XF57) slightly thinned with X20A, over the cockpit unmasked 'red' area.

Brush paint 'Tamiya' Buff (XF57) slightly thinned with X20A, over the lower wing foot board unmasked 'red' area (to give a foot worn effect).

Once dry, remove all covering and masking, including from the open cockpit, the hole in the engine bulk head and the two carburettor air intakes (toothpicks).



Painting - Metal effect:

NOTE: *It was common practice for Sopwith built aircraft to have exposed metal surfaces, such as the fuselage panels and engine cowl, spot burnished. Although the following photograph shows this, I could not confirm that this was carried out on Ansaldo built 'Baby' aircraft. Therefore I chose to ignore the burnished effect.*

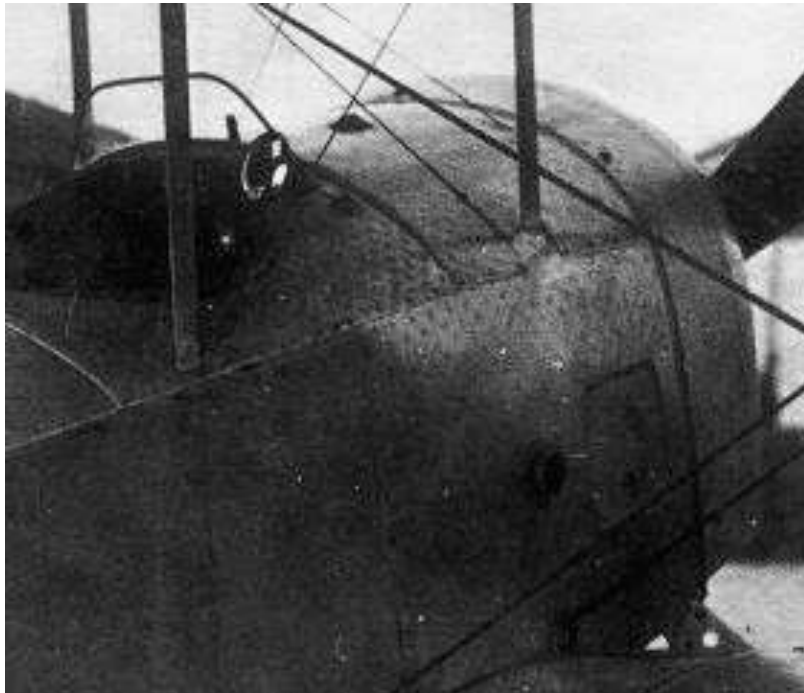

Cover or mask the open cockpit, the hole in the engine bulk head, the two carburettor air intakes (toothpicks) and all of the model **except for the remaining white primed areas**. To cover more awkward areas use 'Humbrol' Maskol or similar.

Airbrush 'Alclad' Black Base (ALC 305-60)XF57) over the unmasked 'white' areas of the fuselage.

Airbrush 'Alclad' Black Base (ALC 305-60)XF57) over the inside and outside of the 3D printed engine cowl.



Once dry, airbrush 'Alclad' Duraluminium (ALC-102) over the same areas.

Once dry, remove all covering and masking from the fuselage, including from the open cockpit, the hole in the engine bulk head and the two carburettor air intakes (toothpicks).



Painting - wood effect:

Mask around the cockpit decking and the foot boards on the lower wing roots (marked 'red' in the following photograph).

NOTE: These areas were previously painted with the base colour of 'Tamiya' Buff (XF57). Refer to Part 2 (Wood Effects) of this build log for more information.



Refer to Part 3 - Brush or sponge 'DecoArt Crafters Acrylic' (Burnt Umber) over the cockpit decking and the foot boards on the lower wing roots to create the desired wood effect.

Once the desired wood effect is achieved, remove all masking.

Additional painting:

Brush paint the added filler cap with 'Mr. Colour' Brass (219) or similar.

Brush paint the added rigging apertures at the lower wing roots, the inside of the two carburettor air intakes and the fasteners on the two side access panels with 'Mr. Colour' Stainless Steel (213) or similar.

Brush paint the cockpit surround padding with 'Humbrol' Leather (62), highlighted with 'Tamiya' Hull Red (XF9).



Decals:

NOTE: *Before applying 'Aviatic' decals, it is important to make sure the surface has a smooth and gloss finish. This will prevent the decal from 'silvering' due to trapped air or surface imperfections under the decal. The 'Aviatic' linen/canvas effect decal (ATT32236) has no colouring, just that of the canvas/linen weave. It is intended to be applied onto a pre-coloured base coat, in this case the previously applied 'Tamiya' Wood Deck Tan (XF78) mixed with Buff (XF57).*

Make sure the surfaces that will have the decal applied are smooth and free from surface imperfections.

Airbrush a sealing gloss coat (avoiding the open cockpit) of 'Alclad' Aqua Gloss (ALC-600) or similar over all sides of the fuselage and the underside of the lower wing roots.

If the finish is not glossy enough, apply a second coat.

NOTE: *The 'Aviatic' decal is supplied as a single A4 sheet. The decal is not 'cookie' cut to suit a particular aircraft. Therefore each decal required must be cut to shape.*

Cut a paper template to the shape of the left side of the fuselage, from the rear edge to the vertical panel line added from the rear edge of the cockpit decking panel. This separates the fuselage side into two decals, which reduces the overall size of the decal, making it easier to apply.

Place the template on the rear (blank) side of the decal sheet and 'lightly' draw the outline onto the decal sheet. Do not press too hard when drawing the outline as it can appear on the decal side of the sheet.

Using the traced outline, cut out the shape of the decal.

Test position the decal on the model surface and check that it is the correct size and does not overlap at an edge of the model.

Soak the decal in warm water for approximately 20 seconds.

Wet the surface where the decal is to be applied.

Slide the decal onto the model surface and remove the decal backing paper.

Slide the decal into position then use a broad, soft brush to brush out water from under the decal.

Finally, use soft tissue paper or cotton buds, to expel any residual water from under and around the decal.

Once the decal has fully dried and set, use a sharp shielded razor blade or scalpel blade to cut into and remove any exposed and not required decal, such as that at the fuselage rear cut out.



Using the above procedure, apply decal to the forward half of the fuselage.

NOTE: *The top of the wing roots, either side of the foot boards, will be painted a different colour and will have decals applied later in this build.*

Using the above procedure, apply decal to the other side of the fuselage, the top and underside of the fuselage and the underside only of the wing roots (each side of the foot boards).

NOTE: *The kit decals can be applied to the linen effect decals and shouldn't need decal setting solutions, as the linen effect decals are smooth and glossy. However, a setting solution, such as 'Microscale' MicroSol can be applied over the kit decals if necessary.*

Once the linen effect decals have been applied and are set, apply the Italian roundel and serial number to each side of the fuselage.

Engine and cowl:

Check that prepared engine assembly locates centrally into the fuselage bulk head, as the location hole in the front of the fuselage is much larger than the location spigot at the rear of the engine.

Dry fit the engine cowl over the test fitted engine to make sure the cowl will fully locate onto the fuselage location lugs and that it does not foul the engine.

Remove the cowl and engine.

Using a slow acting CA adhesive, secure the engine centrally onto the front of the fuselage.

Dry fit the engine cowl and make sure the propeller shaft from the engine is central in the opening of the engine cowl, when viewed from around the cowl. If necessary adjust the engine as required and before the CA adhesive sets.

Once the adhesive has fully set, locate the engine cowl over the engine and onto the fuselage location lugs. Make sure the cowl is fully located against the fuselage.

Secure the cowl onto the fuselage, using a thin CA adhesive around the faces.

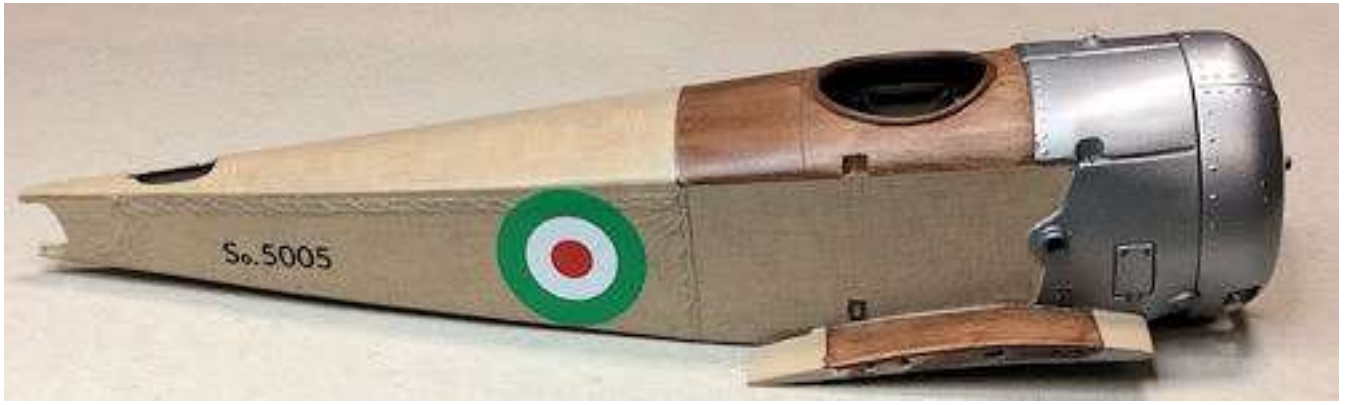

Weathering:

NOTE: *The Ansaldo 'Baby' aircraft were used primarily as training aircraft and therefore flown multiple times daily. It's doubtful that the aircraft were kept as clean as possibly the operational aircraft may have been. Therefore the applied weathering should reflect this (e.g. dirtier).*

To prepare the fuselage and decal surfaces for weathering, airbrush surfaces with a semi-matte coat (e.g. 'Alclad' Light Sheen ALC-311, 'Tamiya' Semi-clear X35 or similar).

Also lightly airbrush the semi-matte sealing coat over the wood effect panels to achieve a semi-gloss varnished effect. These may require a second coat to obtain the finish required.

Refer to Part 3 (Weathering) of this build log for more information - Apply 'Flory Models' Weathering clay wash (Dark Dirt) over the external surfaces of the fuselage. Avoid the engine, cockpit and wood effect areas.



Use a slightly damp tissue or brush to remove the weathering wash, as required, to achieve the desired finish.

Protect and seal the applied weathering by airbrushing the surfaces with a semi-matte coat (e.g. 'Alclad' Light Sheen ALC-311 or Semi-Matte (312) or 'Tamiya' Semi-clear X35 or similar).

Allow the sealing coat to fully dry.

Brush streak 'AK Interactive' Engine Oil (AK 2019) behind the oil tank filler cap.

Dot '502 Abteilung' Smoke (ABT005) oil paint across the lower wing root area (fuselage and wing) and behind the two carburettor air intakes.

Dampen a brush with an enamel thinner, such as 'Tamiya' X20, then remove most of the thinners on a tissue.

Brush the oil paint in the direction of airflow to thin and blend the oil paint to create slight discolouration at those areas.



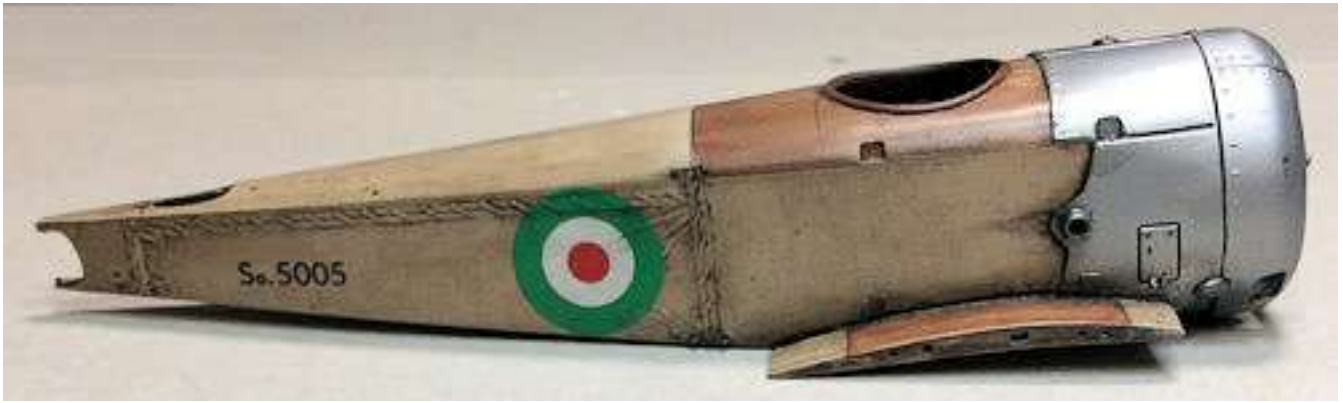

Fuselage joint:

NOTE: The fuselage of this aircraft was constructed such that the rear section could be removed for storage on ships or for transportation or maintenance purposes. The fuselage joint was located at the rear of the cockpit decking panel and around the fuselage. This joint was secured by turnbuckle type locking at the four corners of the fuselage joint, as ca be seen in the following photograph and illustrations.

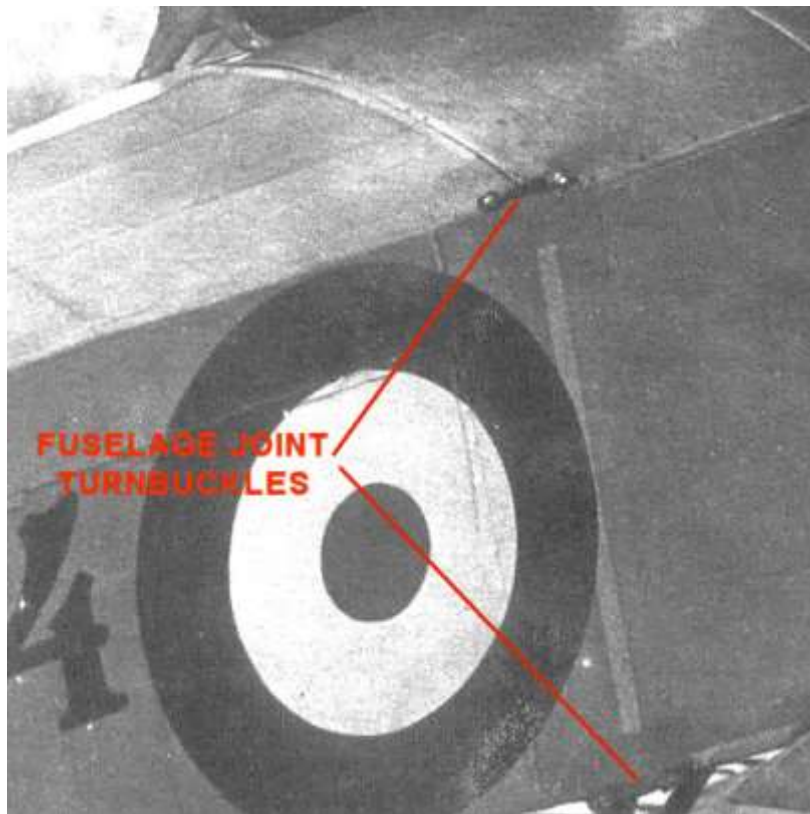

Upper turnbuckle

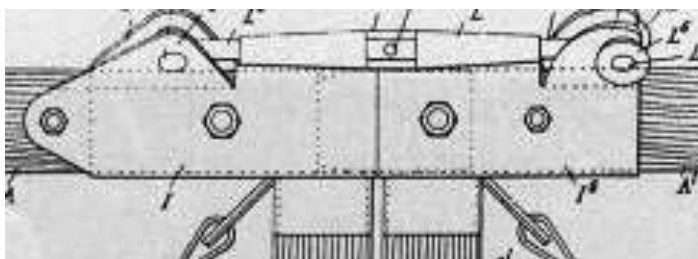

Lower turnbuckle

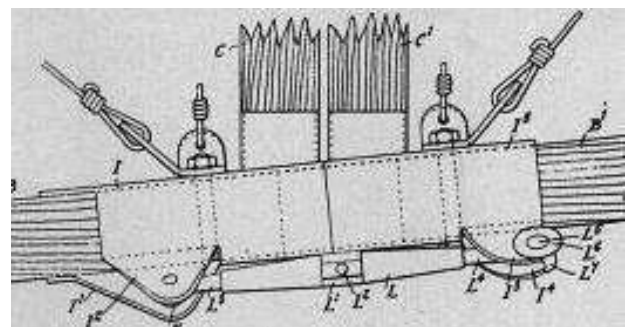

Point mark each corner of the fuselage joint at 2 mm each side of the joint.

Drill a hole of 0.4 mm diameter into the fuselage at the eight point marks made.

Cut four 1:48th scale resin or sintered metal 'anchor points' from 'GasPatch' at the centre of the shanks, to create eight anchor points.

Secure an 'anchor point' into each of the holes, making sure each pair are aligned and inline with the fuselage edge.

NOTE: *In the next step use four 1:48th scale resin or sintered metal 'anchor points' from 'GasPatch', but leave them complete (double ended as supplied) to represent full turnbuckles.*

Secure a 'turnbuckle' across each pair of fuselage 'anchor points'.

Brush paint the eight fuselage anchors and four 'turnbuckles' with 'Tamiya' Gun Metal (X10).

Brush paint the centre section of the four 'turnbuckles' with 'Tamiya' Hull Red (XF9).



PART 13

CONSTRUCTION

PART 13 - CONSTRUCTION

Tail unit and wings:

NOTE: *Construction of the tail unit comprises the tail plane, elevator halves, fin, rudder, support struts, flight control wires and bracing wires.*

Secure the fin into its location recesses on the top surface of the tail plane.

Secure the two elevator halves, at the pre-bent angles, onto their location rods at the trailing edge of the tail plane.

Partly locate an upper wing outer section into the wing centre section.

Apply thin CA adhesive to the exposed locating rods.

Push the two sections fully together making sure there is an approximate 3 degree dihedral angle (wing tip higher) between the centre section and the wing outer section.

Repeat to secure the other outer wing section into the centre section.

Apply CA adhesive along both sides of the two wing joints, to fill and joint gaps.

Once the adhesive has fully set, carefully sand along the joints to remove excess adhesive and to blend the wing section joints.

Check all trailing and leading edges of the upper wing assembly and if necessary, sand edge joints to blend them together.

Check all surfaces for imperfections and if necessary sand them away.

Paint guide:

The wings of this model are a combination of Clear Doped Linen (CDL), olive green and the Italian National colours of red and green.

Upper wing - top surface:

CDL with 'ghost' of the underside outer sections of Italian National red and green (red left side, green right side) showing through the CDL and some internal structure and rib tapes visible.

Upper wing - underside:

CDL with underside outer sections of Italian National red and green (red left side, green right side) and some internal structure and rib tapes visible.

Lower wings - top surface:

Olive green with 'ghost' of the underside outer sections of Italian National red and green (red left side, green right side), slightly showing through the olive green and rib tapes visible.

Lower wings - underside:

CDL with underside outer sections of Italian National red and green (red left side, green right side) and some internal structure and rib tapes visible.

NOTE: *The centre vertical colour for the rudder was left as CDL and not painted white.*

Tail unit:

CDL with the rudder Italian National red and green (green forward vertical, red rear vertical) and some internal structure visible.

Painting:

NOTE 1: *As the underside of the upper and lower wings had outer sections painted red and green, these colours would have shown through the CDL on the top surface of the upper wing and to a lesser extent through the olive green top surfaces of the lower wings. This can be seen in the following photograph, although this is more pronounced as this particular aircraft appears to have CDL lower wings, not olive green. Also visible are the internal wing spars and external rib tapes*

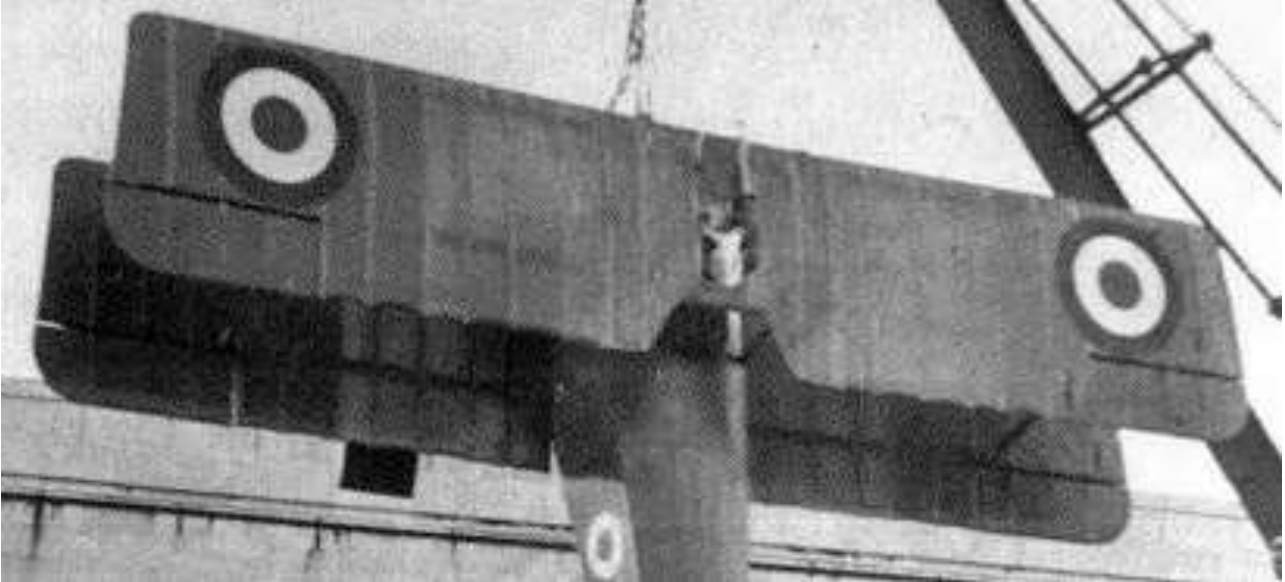

NOTE 2: *The width of the underside red and green sections was not standardised. The aircraft in the previous photograph had these colours applied across six wing ribs. This model represent So.5005, which photographs show had the colours applied across only five wing ribs.*

Prime the tail plane assembly, rudder, ailerons and the upper and lower wings with a white primer, such as 'AK Interactive' White (AK759) or similar.

Check all primed surfaces for imperfections and if necessary, re-sand and then re-prime until a smooth surface is achieved.

Upper wing and ailerons - top surface:

On the top surface of the upper wing assembly, apply strips of 1 mm wide masking tape along each wing rib (leading to trailing edges) and leading edge ribs, but apply 2 mm wide strips along the two wing joints at the centre section.

On the top surface of the upper wing ailerons, apply strips of 1 mm wide masking tap along the rib tapes and around the outer edges.

Across the top surface of the upper wing assembly, mask off to leave strips across the wing to represent the internal front and rear wing spars (see above photograph).

Airbrush 'Tamiya' Smoke (X19) slightly thinned with X20A, around the wing and ailerons masking to create the wing spar and wing rib shadows.

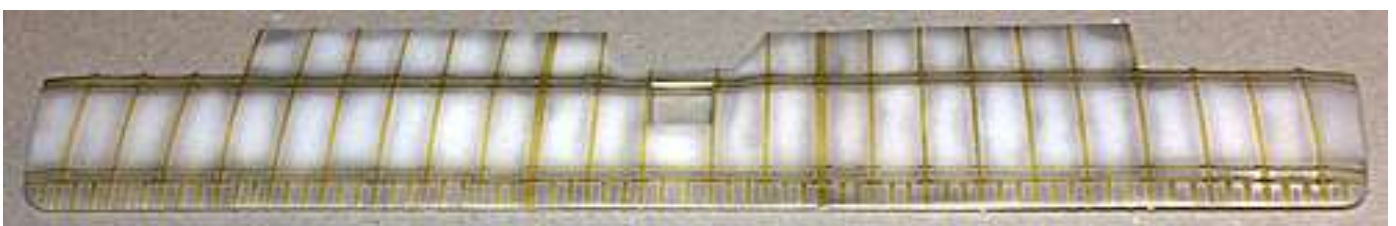

Remove the four strips of masking used to create the shadows of the wing front and rear spars.

At both wing tips, remove the masking tapes from the four outboard wing ribs and the leading edge ribs, leaving the remaining masking tapes in position, from the fifth rib tape inboard.

If there are slight paint ridges left once the tape has been removed, very light sand across the ridges to reduce or remove them. Take care not to sand away the spar shadow paint.

At both wing tips, fully cover or mask off the wing inboard from the from fifth wing ribs.

NOTE: *In the following step, the intention is to create the 'ghost' of the underside red and green outer areas showing through the top of the wing. This 'ghost' is created by lightly blending the previously painted areas to blend the white rib tapes with the main pre-shaded surface of the wing, prior to applying the final colour coat.*

Airbrush a light 'misting' coat of 'Tamiya' Smoke (X19) slightly thinned with X20A over the exposed outer areas of the wing and top surface of the two ailerons.

Remove all remaining masking.

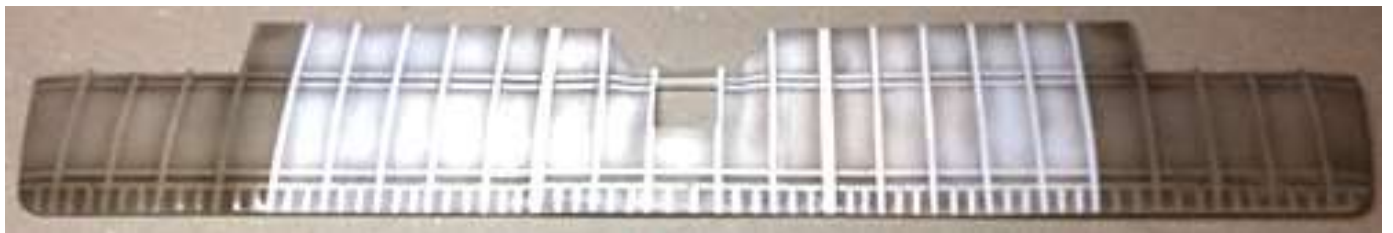

If there are slight paint ridges left once the tape has been removed, very light sand across the ridges to reduce or remove them. Take care not to sand away the spar or wing rib shadow paint.

Cover or mask off the pre-shaded outer wing areas.

NOTE: *During the following step airbrush light coats of the paint, allowing time for the drying effect to take place between coats. The intention is to fade back the pre-shading slightly (not fully cover).*

Lightly airbrush 'Tamiya' Wood Deck Tan (XF78) mixed with Buff (XF57) to 2:1 ration and thinned with X20A, over the exposed wing area.

Once the pre-shading has been faded slightly, but not totally covered, remove all of masking.

Lightly polish the painted surface to remove any roughness and to highlight the wing ribs.



Make sure the surface is smooth and free from surface imperfections.

Airbrush a sealing gloss coat ('Alclad' Aqua Gloss (ALC-600) or similar) over the wing and top surface of the ailerons.

If the finish is not glossy enough, apply a second coat.

NOTE: The 'Aviatic' decal is supplied as a single A4 sheet. The decal is not 'cookie' cut to suit a particular aircraft. Therefore each decal required must be cut to shape.

Cut out paper templates to the shape of the wing outer sections, centre section and aileron top surfaces. This separates the wing decals, which reduces the overall size of the decals, making them easier to apply.

Place the templates on the rear (blank) side of the decal sheet and 'lightly' draw the outlines onto the decal sheet. Do not press too hard when drawing the outlines as it can appear on the decal side of the sheet.

Using the traced outlines, cut out the shape of the decals.

Test position the decals on the model surface and check that they are the correct size and do not overlap at an edges of the wing.

Soak the decals in warm water for approximately 20 seconds.

Wet the surface where the decals are to be applied.

Slide each decal onto the wing surface/aileron top surfaces and remove the decal backing paper.

Slide the decals into position then use a broad, soft brush to brush out water from under the decals.

Use soft tissue paper or cotton buds, to expel any residual water from under and around the decals.

NOTE: As the applied decals have a glossy surface, the normal practice of applying a gloss coat for further decals is not really necessary.

Once the decals are fully set, apply the two kit supplied roundels onto the wing.

Once the decals are fully set, protect the surface by airbrushing a light semi-matte sealing coat, such as 'Alclad' Light Sheen (ALC-311) or similar over the wing. This surface will dull the sheen of the decals and also provide a base for applying weathering later in the build.



Refer to Part 3 (Weathering) of this build log for more information - Apply 'Flory Models' Weathering clay wash (Dark Dirt) over the surface of the wing/ailerons with Grime around the leading and trailing edges.

Use a slightly damp tissue or brush to remove the weathering wash, as required, to achieve the desired finish.

Dot '502 Abteilung' Smoke (ABT005) oil paint behind the four pre-drilled holes in the wing centre section (for locating the photo-etch lifting points) and behind the four pre-drilled holes across the wing leading edge (for locating the aileron control wire guides).

Dampen a brush with an enamel thinner, such as 'Tamiya' X20, then remove most of the thinners on a tissue.

Brush the oil paint in the direction of airflow to thin and blend the oil paint to create slight discolouration at those areas.

Protect and seal the applied weathering by airbrushing the surfaces with a semi-matte coat (e.g. 'Alclad' Light Sheen ALC-311 or Semi-Matte (312) or 'Tamiya' Semi-clear X35 or similar).

Allow the sealing coat to fully dry.



Upper wing - underside surface:

NOTE: *The underside pre-shading for the internal wing ribs and front and rear spars would normally show through the linen covering of the wing as darker shadows, as the day light would be passing through the top surfaces of the wing.*

Across the underside of the upper wing assembly, mask off to leave strips across the wing to represent the internal front and rear wing spars.

Lightly airbrush 'Tamiya' Flat Earth (XF52) slightly thinned with X20A, across the exposed wing spar areas.

Remove all masking.

Lightly airbrush 'Tamiya' Flat Earth (XF52) slightly thinned with X20A, along each wing/aileron rib and around the leading and trailing edges of the wing/ailerons.

Cover or mask off the outer five wing rib area at both wing tips.



Lightly airbrush 'Tamiya' Wood Deck Tan (XF78) mixed with Buff (XF57) to 2:1 ration and thinned with X20A, over the exposed wing area.

Once the pre-shading has been faded slightly, but not totally covered, remove all of masking.

Cover or mask off the wing, except for the outer five rib tapes area.

Lightly airbrush the outer exposed area at the **left** wing tip and aileron using 'Tamiya' Red (X7).

Lightly airbrush the outer exposed area at the **right** wing tip and aileron using 'Tamiya' Green (X5) mixed with approximately 15% of 'Tamiya' Grey Green (XF76).

Remove all masking.

Lightly polish the painted surface to remove any roughness.



Make sure the surface is smooth and free from surface imperfections.

Airbrush a sealing gloss coat ('Alclad' Aqua Gloss (ALC-600) or similar) over the wing.

If the finish is not glossy enough, apply a second coat.

NOTE: Refer to the procedures carried out for the top surface of the upper wing.

Cut paper templates and use them to cut out the 'Aviatic' linen effect decals to fit the underside of the wing and ailerons.

Apply the decals to the underside of the wing/ailerons.

Once the decals are fully set, protect the surface by airbrushing a light semi-matte sealing coat, such as 'Alclad' Light Sheen (ALC-311) or similar over the wing.

Refer to Part 3 (Weathering) of this build log for more information - Apply 'Flory Models' Weathering clay wash as desired.

Protect and seal the applied weathering by airbrushing the surfaces with a semi-matte coat (e.g. 'Alclad' Light Sheen ALC-311 or Semi-Matte (312) or 'Tamiya' Semi-clear X35 or similar).

Allow the sealing coat to fully dry.



Lower wings - underside:

Use the same procedure to finish the underside of the lower wings and ailerons as used for the underside of the upper wing. The outer colouring should match the underside of the upper wing.

Lower wings - top surfaces:

NOTE: The top surface of the lower wings is an olive colour, rather than plain CDL. This was a colour used on many Italian aircraft to reduce the glare from the wings doped surface that could affect the pilot's vision. As such the internal spars/wing ribs and underside colours would not be visible through the olive coloured linen covering.

Check the white primed surfaces for imperfections and if necessary, re-sand and then re-prime until a smooth surface is achieved.

Airbrush 'Tamiya' Smoke (X19) slightly thinned with X20A, along each wing/aileron rib, around the wing/aileron leading and trailing edges. This pre-shading needs to be a heavier coat than that applied previously in order that it will show faded through the olive paint.

NOTE: During the following step airbrush light coats of the paint, allowing time for the drying effect to take place between coats. The intention is to fade back the pre-shading slightly (not fully cover).

Lightly airbrush 'Tamiya' Khaki Drab (XF51) thinned with X20A, over the wing/ailerons to fade, but not totally cover, the applied pre-shading.

Lightly polish the painted surface to remove any roughness and to highlight the wing ribs.

Make sure the surface is smooth and free from surface imperfections.

Airbrush a sealing gloss coat ('Alclad' Aqua Gloss (ALC-600) or similar) over the wing.

If the finish is not glossy enough, apply a second coat.

As for the top surface of the wing, cut paper templates and then the required 'Aviatic' linen effect decals. Apply the decals to the wing and ailerons.

Once the decals are fully set, protect the surface by airbrushing a light semi-matte sealing coat, such as 'Alclad' Light Sheen (ALC-311) or similar over the wing/ailerons. This surface will dull the sheen of the decals and also provide a base for applying weathering later in the build.

Refer to Part 3 (Weathering) of this build log for more information - Apply 'Flory Models' Weathering clay wash (Dark Dirt) over the surface of the wing/ailerons with Grime around the leading and trailing edges.

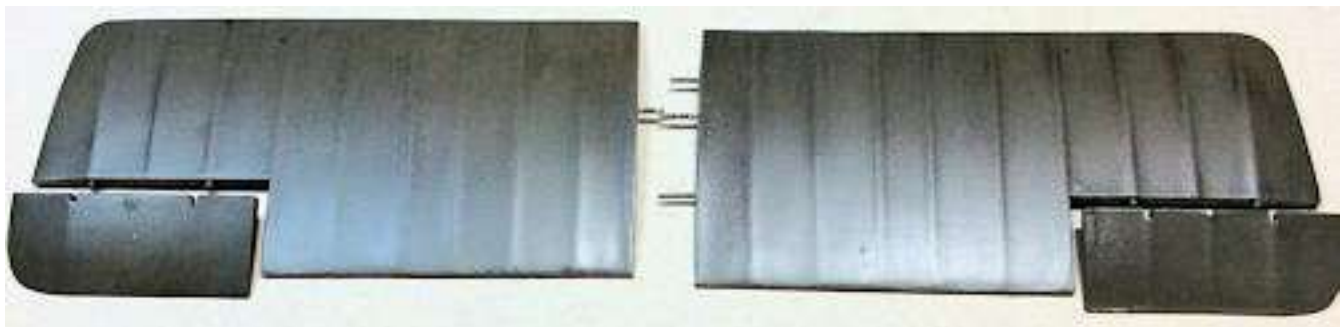
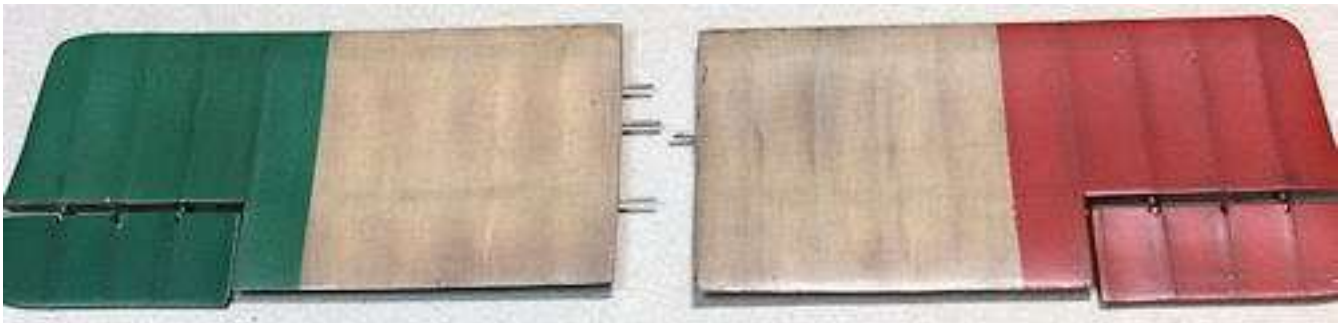

Tail plane assembly:

Use the same procedure to finish the underside of the lower wings as used for the underside of the upper wing.

Rudder:

NOTE: The central vertical stripe of the rudder National marking was not painted white, but left as doped linen. This was common practice for Ansaldo built aircraft.



Lightly airbrush 'Tamiya' Wood Deck Tan (XF78) mixed with Buff (XF57) to 2:1 ration and thinned with X20A, over the rudder.

Cover or mask off the rudder, except for the forward vertical green stripe area.

Lightly airbrush the exposed area of the rudder using 'Tamiya' Green (X5) mixed with Grey Green (XF76) at a 60-40% ratio.

Cover or mask off the rudder, except for the rear vertical green stripe area.

Lightly airbrush the exposed area using 'Tamiya' Red (X7).

Remove all masking.

Make sure the surface is smooth and free from surface imperfections.

Lightly polish across the painted surface to highlight the ribs.

Airbrush a sealing gloss coat ('Alclad' Aqua Gloss (ALC-600) or similar) over the wing.

If the finish is not glossy enough, apply a second coat.

NOTE: Refer to the procedures carried out for the top surface of the upper wing.

Cut paper templates and use them to cut out the 'Aviatic' linen effect decals to fit the rudder then apply the decals to the rudder.

Once the decals are fully set, protect the surface by airbrushing a light semi-matte sealing coat, such as 'Alclad' Light Sheen (ALC-311) or similar over the wing.

Refer to Part 3 (Weathering) of this build log for more information - Apply 'Flory Models' Weathering clay wash as desired.

Protect and seal the applied weathering by airbrushing the surfaces with a semi-matte coat (e.g. 'Alclad' Light Sheen ALC-311 or Semi-Matte (312) or 'Tamiya' Semi-clear X35 or similar).

Allow the sealing coat to fully dry.

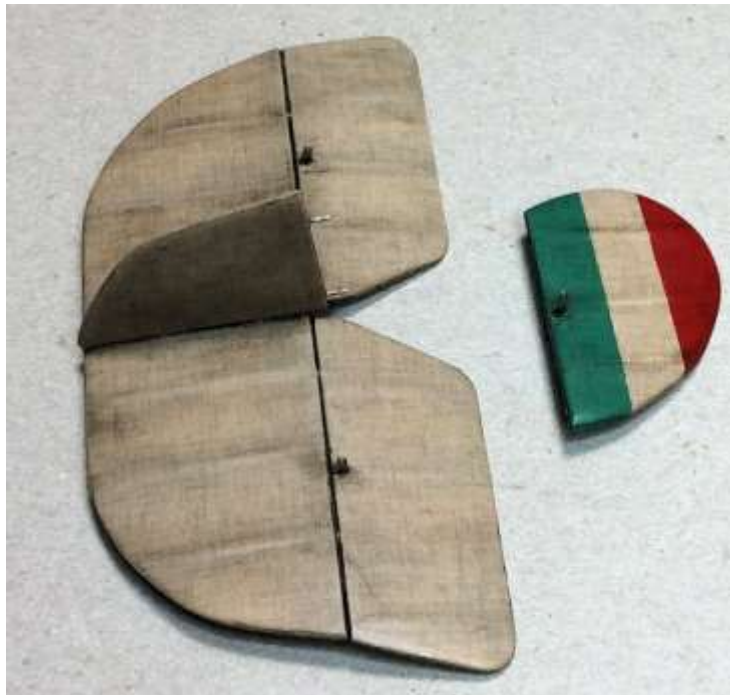

Brush paint the control horns on the four ailerons, elevator and rudder with 'Tamiya' Rubber Black (XF85) or similar.

Main and tail floats:

The main and tail floats had wood panels nailed to the internal structure. Inside each float were canvas 'bulk heads' to separate the float compartments. Each of the three compartments in the main floats were accessed through a circular cover on the top surface of the floats. At the front and rear edges of the main floats were reinforced with Spruce end caps. Across each main float were recesses to locate the float cross beams and these recesses were covered with panels.

These details are not reproduced on the kit supplied floats.

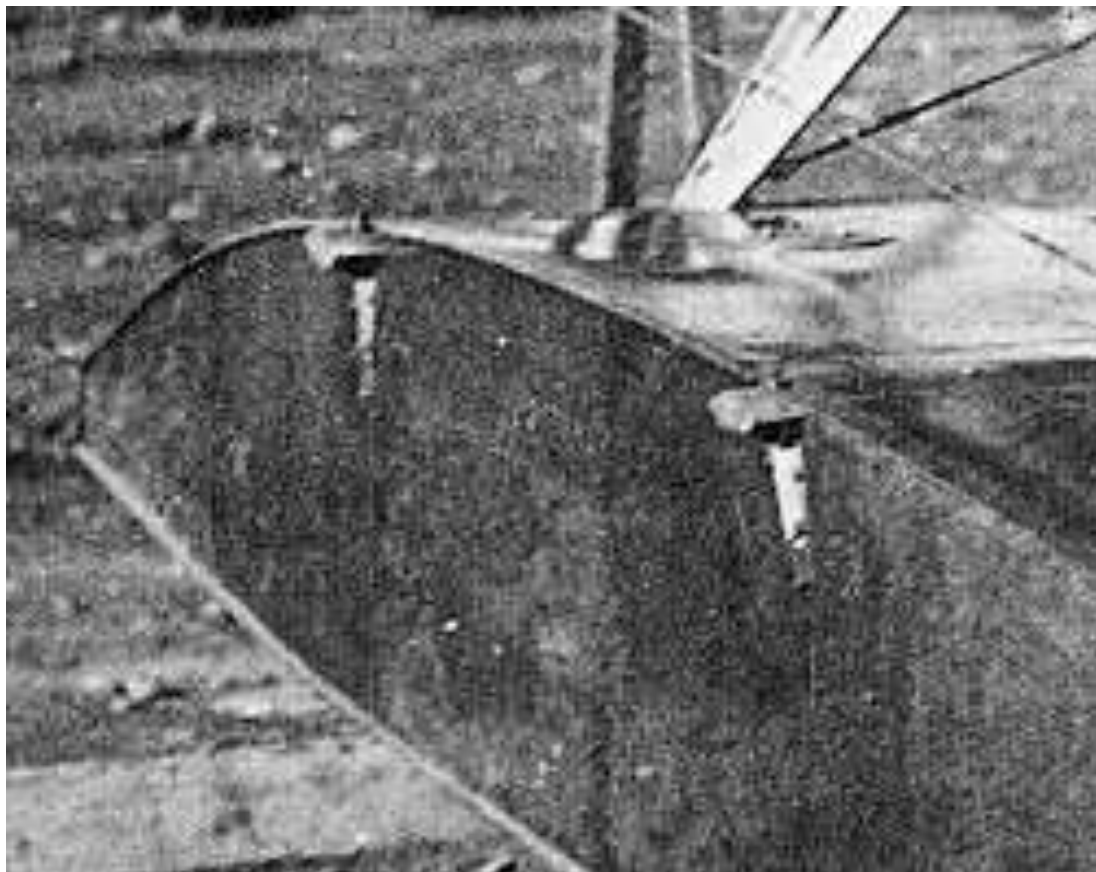
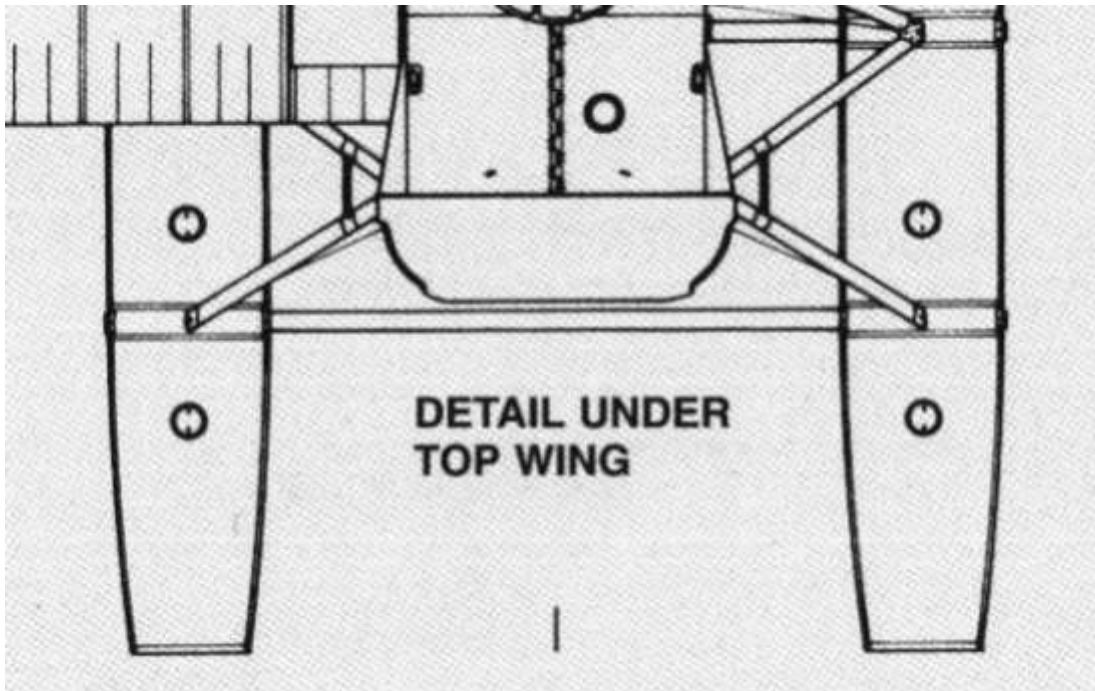

Using a rule as a guide and a sharp scribe, create panel lines around each float.

Using a riveting tool, such as 'Rosie the Riveter' or 'RB Promotions' riveter or similar tool, create nail lines to each side of the scribed panel lines.

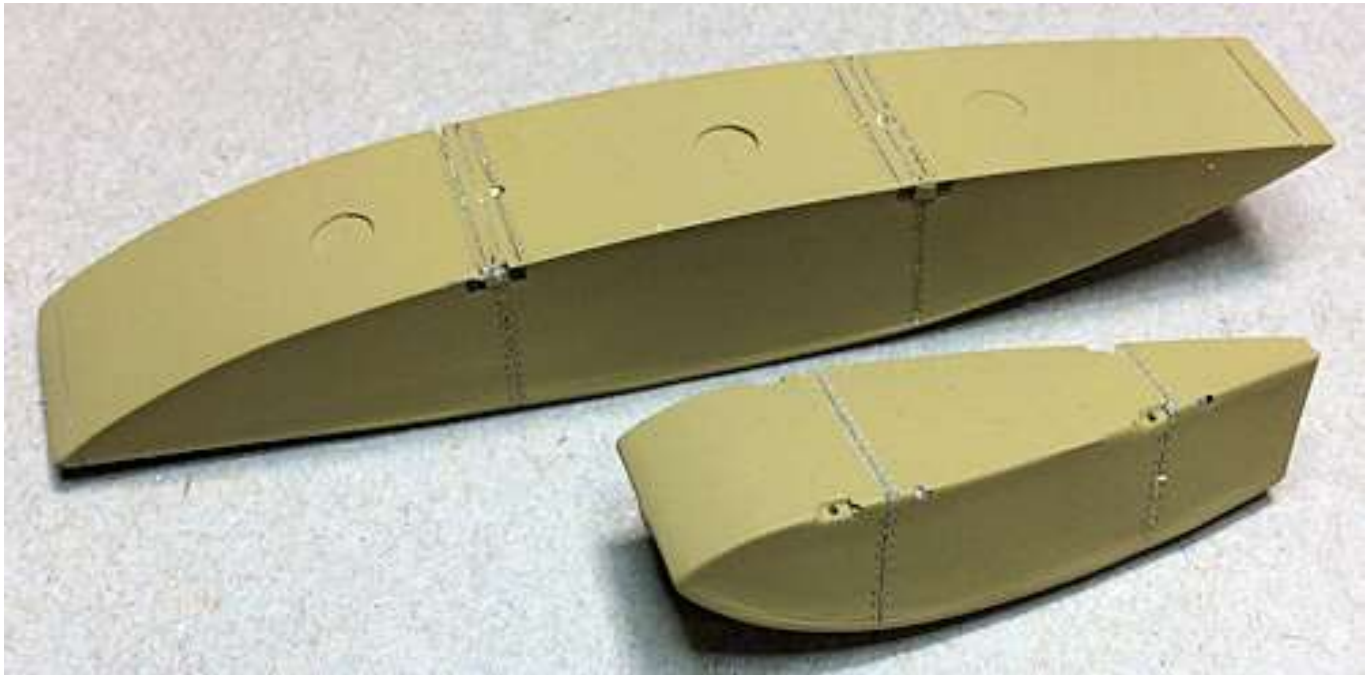

Airbrush prime the three floats with a grey primer, such as 'AK Interactive AK-758 or similar.

Airbrush each float with 'Tamiya' Dark Yellow (XF60) or similar.

Mask off the centre section of each float.

Refer to Part 3 - Brush or sponge 'DecoArt Crafters Acrylic' (Burnt Umber) over exposed areas of each float.

Remove all masking.

Once fully dry, *gently* mask off the painted sections of each float.

Brush or sponge 'DecoArt Crafters Acrylic' (Burnt Umber) over the centre sections of each float.

Remove all masking.

Lightly polish or sand off the applied Burnt Umber from the side edges of the main floats and tail float, to show the under colour (to represent the beading edges on the floats).

Airbrush several light coats of thinned 'Tamiya' Clear Yellow (X24) to represent a varnish finish.

Remove the kit supplied photo-etch parts (5 x 6, 6 x 4 and 5 x 4) from the sheet and remove any tags from the edges of the parts.

Position all phot-etch parts onto a sticky surface, such as masking tape or 'UHU' white tack.

Airbrush the photo-etch parts with a black base, such as 'Alclad' Gloss Black Base (ALC-305-60) or similar.

Airbrush the photo-etch parts with a steel colour, such as 'Alclad' Steel (ALC-112) or similar.

NOTE: *The forward photo-etch plates (6) are not vertical, but angled forwards at the bottom (refer to previous photograph on page 105).*

Following the kit instructions, secure each photo-etch part onto the floats, with thin CA adhesive.

Airbrush the floats with several light coats of a semi-matte coat, such as 'Alclad' Light Sheen ALC-311 or 'Tamiya' Semi-clear X35 or similar.

Refer to Part 3 (Weathering) of this build log for more information - Apply 'Flory Models' Weathering clay wash (Dark Dirt) over the floats.

Remove the weathering wash to achieve the desired finish.

Seal the applied weathering by airbrushing the floats with a semi-matte coat, such as 'Alclad' Light Sheen ALC-311 or 'Tamiya' Semi-clear X35 or similar.



Assembly:

Test fit the tail plane assembly into the rear, top of the fuselage, making sure the it sits horizontal to the fuselage and its leading edge is at 90 degrees to the fuselage.

Secure the tail plane assembly to the fuselage.

NOTE: *I found that the rear ends of the fuselage stops the rudder from contacting the rear of the fin. Therefore I need to trim away the end of the rear of the fuselage to achieve a good fit of the rudder. This removed the locating hole for the float rudder operating bar.*

Test fit the rudder onto the two pre-installed fin rods. Make sure the rudder sit against the rear edge of the fin.

Secure the rudder to the fin.

Test fit the four ailerons to their wing positions and if desired, slightly bend the ailerons up or down (on the same side of the wings) to animate them.

NOTE: *During the next step, make sure the lower wings are fitted with a 3 degree dihedral angle (higher at the wing tip).*

Test fit the two lower wings into the fuselage wing roots, locating them with the pre-installed locating rods.

Secure the two lower wings onto the fuselage.



Tail plane support struts:

NOTE: *The leading edge of the tail plane was braced to the bottom edge of the fuselage rear by struts. These are supplied in the kit as metal rod, but in reality were aerofoil shaped, as for the wing and float struts. I decided to create these two struts using micro-tube and rod.*



Roll cut two lengths of 0.8 mm diameter tube (e.g. 'Albion Alloy's MBT08 or similar) that has a 0.6 mm internal bore. Length approximately 30 mm.

Slide the 0.8 mm tubes onto a length of 0.3 mm diameter rod (e.g. 'Albion Alloy's MBR03 or similar).

NOTE: *To create aerofoil profiles, I use the 'Strutter' tool from Albion Alloy's. Otherwise you can use a smooth jaw vice to form the profile.*

Gradually crush the 0.8 mm tubes onto the 0.3 mm rod to form a flatter profile.

Remove the 0.3 mm rod.

Check the lengths of the 0.8 mm tubes by placing them against the pre-moulded location holes at the bottom edge of the fuselage rear and the underside leading edge of the tail plane, midway between the two outer ribs of the tail planes.

Chamfer the ends of the tubes so that they sit fully against the fuselage and tail plane.

Cut two lengths of 0.3 mm diameter rod longer than the 0.8 mm tubes.

Insert the rods into the tubes and secure by either soft soldering or using CA adhesive.

Cut the rod ends to leave 1 mm exposed.

Drill into the pre-moulded hole locations in the fuselage using a 0.4mm diameter drill.

Mark the location of the end of the tube on the underside of the tail plane.

Drill partly into, **but not through**, the underside of the tail plane at the marked location, using a 0.4mm diameter drill.

Bend the exposed 0.3 mm rod ends so that the tube assemblies fit into the pre-drilled holes with the outer tube chamfered ends contacting the fuselage and tail plane surfaces.

Treat the tubes with a painting primer, such as 'VMS' Metal Prep 4K or similar. This should provide a keying surface for subsequent painting.

Assembly (cont'd):

Test fit each of the four support struts into their location holes in the top, sides of the tail float (shorter struts to the front, longer to the rear).

If necessary, sand the bottom of the struts in order to achieve a full fit into the strut recesses in the float.

Wing/cabane struts - painting:

NOTE: *At this stage of the build, all of the wing and cabane struts can be painted in order to keep the final finish the same on all of the struts. A white primer is used as this will help to create a lighter coloured wood finish. The struts to be painted are the wing struts (x 4) - fuselage cabane struts (x 4) - tail plane bracing struts (x 2).*

File or sand away any surface seam lines or residual resin from all of the struts.

Airbrush prime the struts with a white primer, such as 'AK Interactive AK-759 or similar.

Airbrush the struts with 'Tamiya' Deck Tan (XF55) or similar.

Refer to Part 3 - Brush or sponge 'DecoArt Crafters Acrylic' (Burnt Umber) over the struts.

Airbrush the struts with several semi-matte coats, such as 'Alclad' Light Sheen ALC-311 or 'Tamiya' Semi-clear X35 or similar, mixed with 'Tamiya' Clear Yellow (X24) to represent the varnish finish.

Clean off any residual primer or paint from the end locating rods of each strut.

Float and tailplane struts - painting:

NOTE: *The struts to be painted are the tail float struts, (x 4) - main float 'N' struts (x 2) and main float cross struts (x 2).*

File or sand away any surface seam lines or residual resin from all of the struts.

Airbrush prime the struts with a grey primer, such as 'AK Interactive AK-758 or similar.

Airbrush 'Alclad' Black Base (ALC 305-60)XF57) over the struts.

Once dry, either airbrush 'Alclad' Duraluminium (ALC-102) or brush paint 'Mr. Colour' Stainless Steel (213) over the struts.

Assembly (cont'd):

At the top of the tail float, drill holes of 0.4 mm diameter into the float, inboard from the strut location holes. Also drill holes behind the front strut location holes and in front of the rear strut location holes.

Drill holes of 0.4 mm diameter into the bottom face of the fuselage rear to correspond to the holes drilled into the tail float.

Secure a 'GasPatch' anchor point into each of the holes in the tail float and fuselage.

Rigging the tail float:

NOTE: *The pre-rigging for the tail float will be fitted to the fuselage, rather than to the fuselage. This is because initially, the tail float will only be attached to the fuselage by its four struts, which makes it susceptible to breakage when flexed during the final tensioning of the rigged lines.*

Cut two long lengths of 0.08 mm diameter clear mono-filament (e.g. 'Stroff' GTM or similar).

Roll cut three short lengths of 0.4 mm diameter Nickel-Silver tube (e.g. 'Albion Alloy's' NST04 or similar).

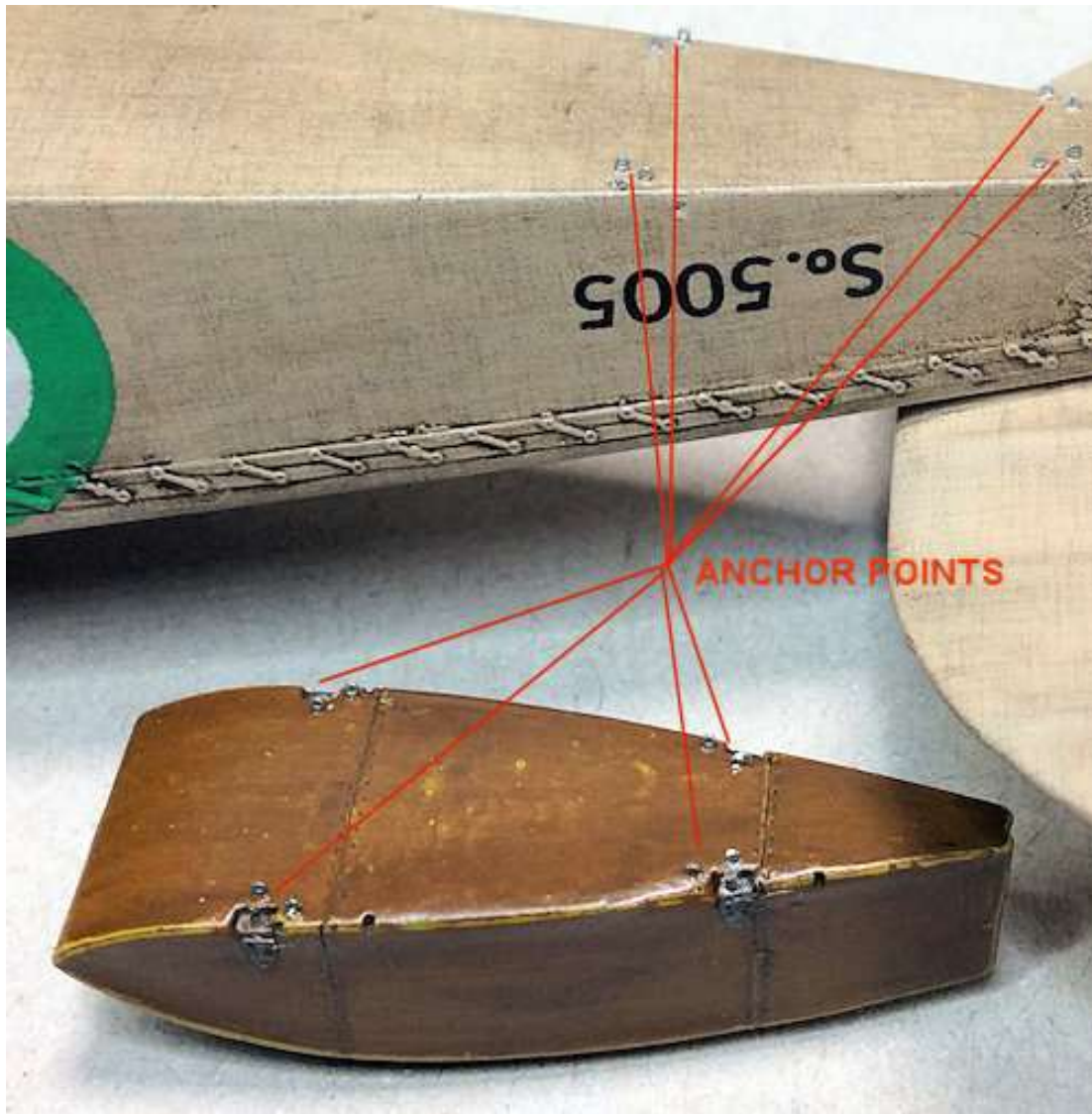

Break away a 'GasPatch' 1:48th scale turnbuckle (Type C) from its base and remove any residual tag from the eye end.

Pass one line through a cut tube then through the eye end of the turnbuckle.

Loop the line back through the tube.

Slide the tube up to, but not touching, the eye end of the turnbuckle.

Secure the tube to the line using thin CA adhesive.

Repeat the procedure to add the second turnbuckle line to the other end of the turnbuckle.

Cut away the exposed tag from the line at the tube ends.

Pass one turnbuckle line through the remaining cut tube then through an anchor point on the bottom, rear of the fuselage.

Loop the line back through the tube.

Slide the tube up to, but not touching, the fuselage anchor point. Leave a small gap between the two tubes on the line.

Secure the tube to the line using thin CA adhesive.

Cut away the exposed tag from the line at the tube end.

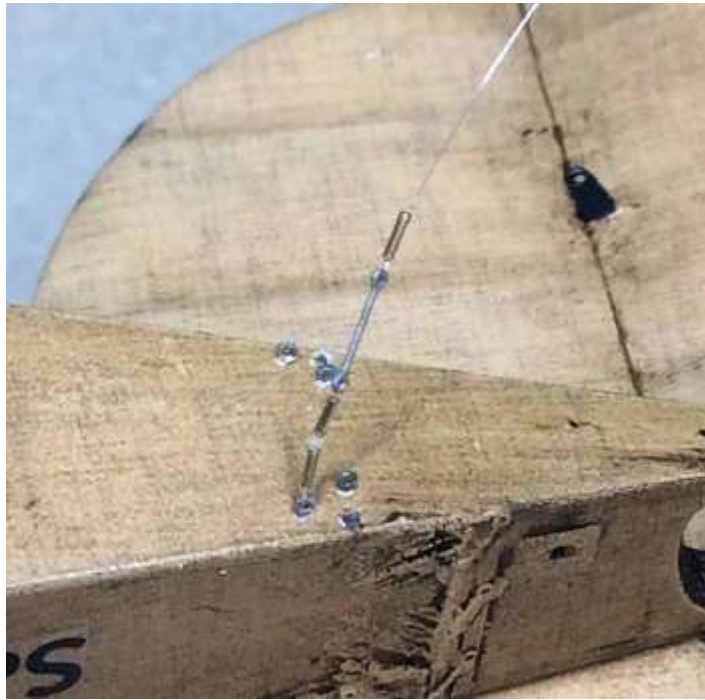

Repeat the procedure to add a turnbuckle line to the remaining seven anchor points on the bottom, rear of the fuselage.

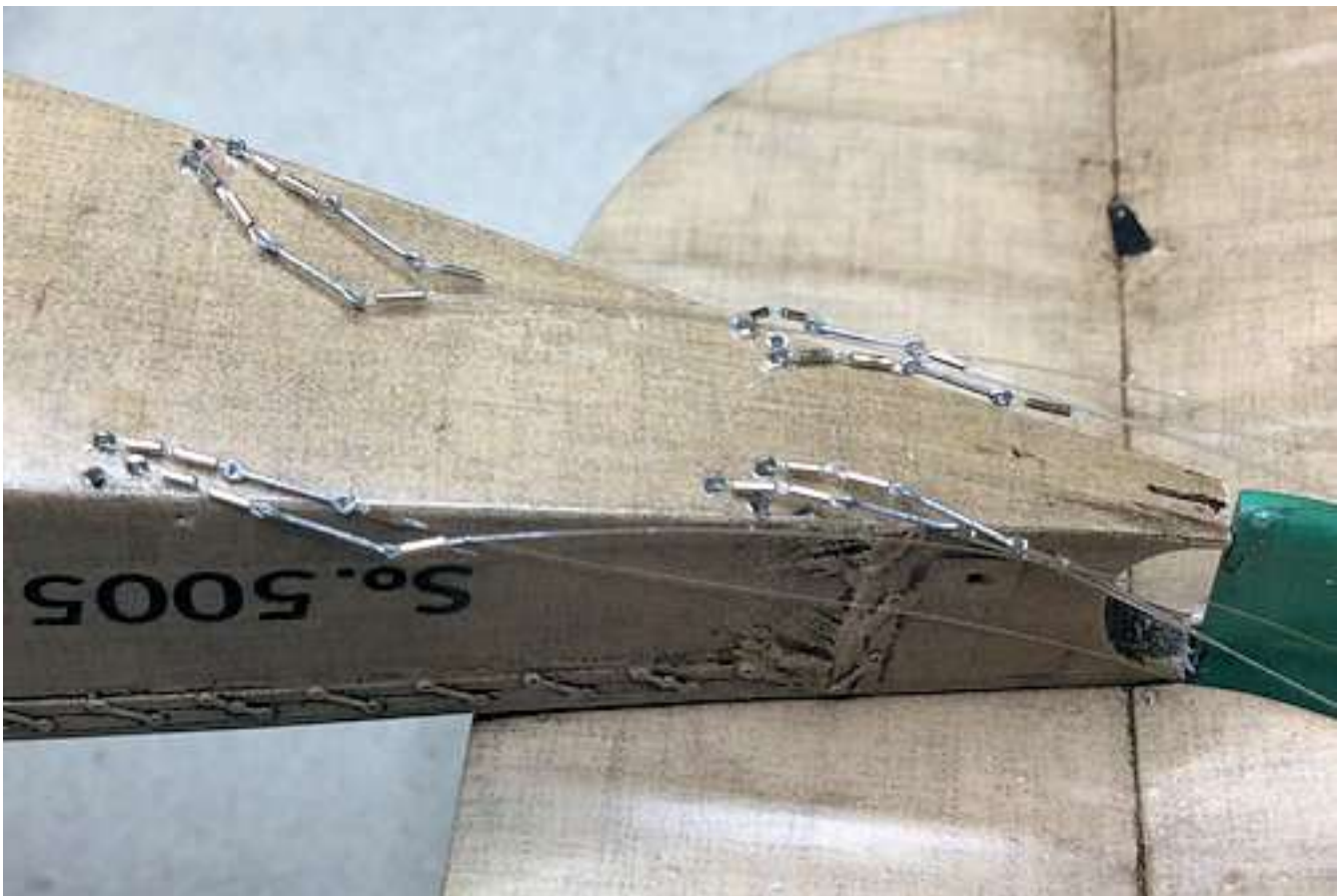

Hold the lines clear of the fuselage surface and brush paint the centre section of each turnbuckle with 'Tamiya' Hull Red (XF9) or similar.

NOTE: During the next step make sure all of the rigging lines are kept clear of the applied adhesive.

Secure the four support struts for the tail float into their pre-drilled holes in the fuselage (shorter struts to the front, longer to the rear).

NOTE: The support struts have since been painted with a metal finish.

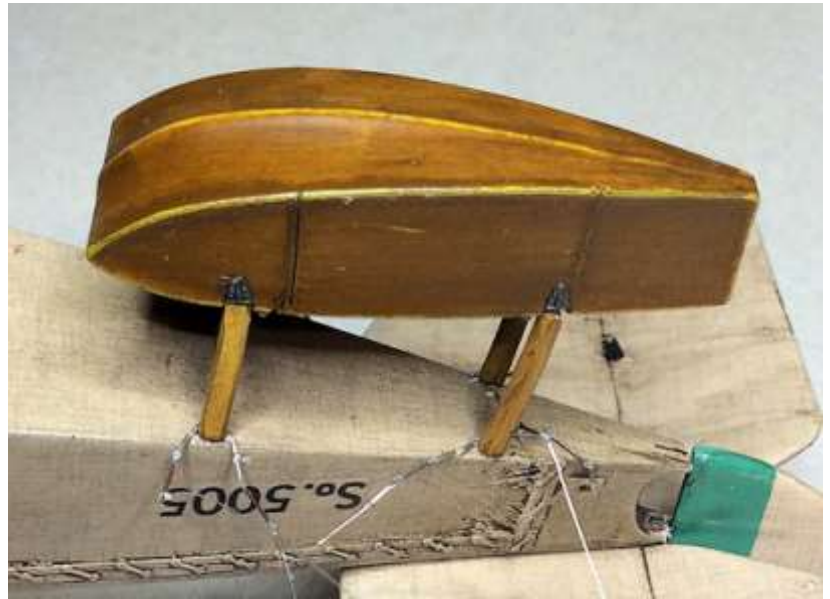

Roll cut eight short lengths of 0.4 mm diameter Nickel-Silver tube (e.g. 'Albion Alloy's' NST04 or similar).

Pass the end of one of the pre-installed rigging lines through a cut tube.

Pass the end of the line through the eye of the diagonally opposite anchor point on the tail float.

Loop the line back through the tube.

Keeping the line taut, slide the tube up to the anchor point.

Secure the tube to the lines.

Cut away the exposed tag from the line at the tube end.

Repeat the procedure to rig the remaining seven bracing lines.

NOTE: The support struts have since been painted with a metal finish.



Tail float rudder:

NOTE: To install the tail float rudder required modifications due to the following:

The rear edge of the fuselage had previously been trimmed to allow the aircraft rudder to be fitted. This also removed the locating hole for the float rudder operating bar.

Once installed it was found that the rear edge of the tail float was not vertical to the fuselage, which meant the float rudder operating bar was at an angle and not vertical.

The supplied float rudder has the operating bar attached. When the bottom of the rudder is aligned with the bottom of the tail float, the resin operating bar does not reach the fuselage.

The fuselage recess forward from the bottom of the aircraft rudder had a vertical bar which served to attach the bottom of the aircraft rudder and as an attachment point for the underside tail plane bracing wires. The kit supplied tail float rudder only has a short length of resin moulded at the top of the operating bar to represent this bar. Also the actual bar was not attached to the float rudder operating bar, but was farther back and aligned with the rear of the fin/rudder leader edge.

The locating holes in the photo-etch control horn for the top of the float operating bar is much bigger than the rod it's supposed to locate on.

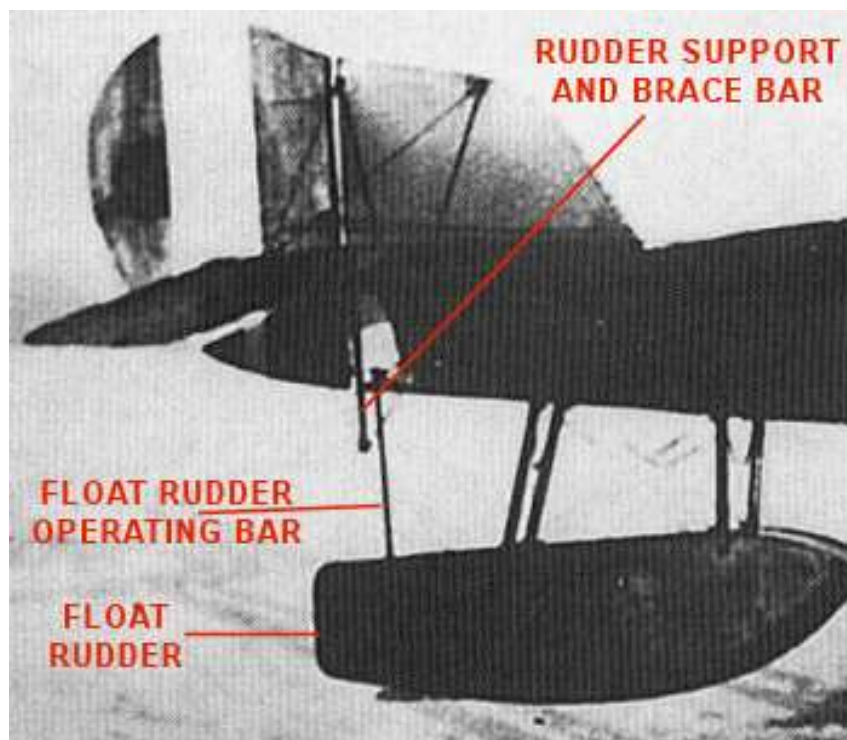

Supporting the model and tail float, carefully sand the rear edge of the tail float vertical to the fuselage.

Position the float rudder against the sanded rear edge of the float and mark the position of the operating bar on the underside of the fuselage.

Drill a hole of 1.0 mm diameter at the marked position, through the underside of the fuselage and into the recess.

Cut away the resin surround of the float rudder operating bar, to leave just the brass rod. Measure the distance from the top, rear of the tail float to the underside of the fuselage. Roll cut a length of 1.2 mm diameter tube (e.g. 'Albion Alloy's' MBT12 or similar) to that distance.



Locate the cut tube onto the float rod, touching the float rudder and secure in position. Measure the distance from the top of the added tube to the top of the exposed rod. Roll cut a length of 0.8 mm diameter tube (e.g. 'Albion Alloy's' MBT08 or similar) to that distance. Locate the cut tube onto the exposed end of the float rod, touching the previously added tube and secure in position. Check that the operating bar assembly can be inserted into the drilled hole and that the float rudder rests against the rear edge of the float.



Roll cut a length of 0.8 mm diameter tube (e.g. 'Albion Alloy's' MBT08 or similar) to 15 mm length. Roll cut a length of 1.2 mm diameter tube (e.g. 'Albion Alloy's' MBT12 or similar) to 1.5 mm length. Secure the cut 1.2 mm tube onto one end of the 0.8 mm diameter tube. Use a triangular needle file to create a shallow groove across the bottom centre of the 0.8/1.2 mm diameter tube



Treat all of the created metal tubes and the photo-etch control horn (kit part 15) and float keel (kit part 8) with a painting primer, such as 'VMS' Metal Prep 4K or similar. This should provide a keying surface for subsequent painting.

Airbrush prime the tail float rudder assembly and the created aircraft rudder/brace bar with a grey primer (e.g. 'AK Interactive' AL-758 or similar).

Airbrush the float rudder with 'Tamiya' Dark Yellow (XF60) or similar.

Refer to Part 3 - Brush or sponge 'DecoArt Crafters Acrylic' (Burnt Umber) over exposed areas of each float.

Airbrush the rudder with several semi-matte coats, such as 'Alclad' Light Sheen ALC-311 or 'Tamiya' Semi-clear X35 or similar, mixed with 'Tamiya' Clear Yellow (X24) to represent the varnish finish.

Brush paint the two 'metal' plates on each side of the float rudder with 'Mr. Colour' Stainless Steel (213).

Brush paint the rudder operating bar, the aircraft rudder/brace bar and the control horn with 'Tamiya' Rubber Black (XF85) or similar.

Scrape away the paint/primer from the rudder operating bar, only where it will contact the rear face of the tail float.

Locate the rudder operating bar into the pre-drilled hole and align the bottom of the rudder to the bottom edge of the tail float with the bar central on the rear edge of the tail float.

Secure in position.

Insert the aircraft rudder/brace bar into the pre-drilled hole so that the top of the bar contacts the top of the fuselage recess and the created groove at the bottom of the bar is aligned to the wings (across the aircraft).

Secure in position.

Float rudder control horn - pre-rig:

Roll cut two short lengths of 0.4 mm diameter Nickel-Silver tube (e.g. 'Albion Alloy's' NST04 or similar).

Cut two long lengths of 0.08 mm diameter clear mono-filament (e.g. 'Stroft' GTM or similar).

Pass one end of a line through a cut tube.

Pass the end of the line through the an eye end of the float rudder control horn.

Loop the line back through the tube.

Slide the tube up to, but not touching, the control horn.

Secure the tube to the lines.

Cut away the exposed tag from the line at the tube end.

Repeat the procedure to pre-rig the other end of the control horn.

Elevator control - pre-rig:

Cut four long lengths of 0.08 mm diameter clear mono-filament (e.g. 'Stroft' GTM or similar).

Make sure the four elevator control line exit holes in the fuselage are clear of decal, paint or primer. If necessary clear the holes using a 0.3 mm diameter drill.

Pass one end of the lines into the four pre-drilled holes and secure in position with CA adhesive.

Aircraft rudder - pre-rig:

Use the same procedure to pre-rig the two aircraft rudder control lines from the fuselage.

Aircraft rudder - final rigging:

Roll cut four short lengths of 0.4 mm diameter Nickel-Silver tube (e.g. 'Albion Alloy's' NST04 or similar).

Pass the free end of the fuselage lines through a cut tube

Pass the lines through the eye end of their respective rudder control horn.

Loop the lines back through the tubes.

Keeping the lines taut, slide the tubes up to, but not touching, the control horns.

Secure the tubes to the lines.

Cut away the exposed tag from the lines at the tube ends.

Cut one long length of 0.08 mm diameter clear mono-filament (e.g. 'Stroft' GTM or similar).

Make sure the pre-drilled hole in the rear of the rudder is clear of paint or primer. If necessary clear the holes using a 0.3 mm diameter drill.

Pass one end of a line through a cut tube.

Pass the end of the line through the eye end of a rudder control horn.

Loop the line back through the tube.

Slide the tube up to, but not touching, the control horn.

Secure the tube to the lines.

Cut away the exposed tag from the line at the tube end.

Pass the free end of the line through the pre-drilled hole in the rudder.

Pass the line through a cut tube.

Pass the end of the line through the eye end of the other rudder control horn.

Loop the line back through the tube.

Keeping the line taut, slide the tube up to, but not touching, the control horn.

Secure the tube to the lines.

Cut away the exposed tag from the line at the tube end.

Elevator - final rigging:

Use the same procedure to final rig the four elevator control lines.

Float rudder - final rigging:

NOTE: *In the next step make sure the control horn is positioned with its straight edge facing the fuselage.*

Make sure the pre-drilled holes in the rear of the fuselage are clear of paint or primer. If necessary clear the holes using a 0.3 mm diameter drill.

Locate the rudder control horn onto the top of the operating bar inside the fuselage recess.

Secure in position.

Pass the two control lines through their respective pre-drilled fuselage holes.

Keep the lines taut and secure in position with CA adhesive.

Fin - cross bracing:

Front bracing wire:

Make sure the pre-drilled holes in the trailing edge of the tail plane and the top of the fin are clear of paint or primer. If necessary clear the holes using a 0.3 mm diameter drill.

Roll cut eight short lengths of 0.4 mm diameter Nickel-Silver tube (e.g. 'Albion Alloy's' NST04 or similar).

Cut a long length of 0.12 mm diameter mono-filament (e.g. 'Steelon GTM' or similar).

Secure one end of the line into the exposed bottom internal bore of the fitted rudder/brace bar.

Slide two cut tubes onto the free end of the line.

Pass the line through the **rear** of the two pre-drilled holes in that side of the trailing edge of the tail plane.

Slide two cut tubes onto the free end of the line.

Pass the free end of line through the **rear** pre-drilled hole at the top of the fin.

Slide two cut tubes onto the free end of the line.

Pass the line through the **rear** of the two pre-drilled holes in that side of the trailing edge of the tail plane.

Slide two cut tubes onto the free end of the line.

Keep the complete line taut and secure the line over the groove previously created at the bottom of the rudder/brace bar, using CA adhesive.

Cut away the residual line as close as possible to the bottom of the rudder/brace bar.

Rear bracing wire:

Make sure the pre-drilled holes in the trailing edge of the tail plane and the top of the fin are clear of paint or primer. If necessary clear the holes using a 0.3 mm diameter drill.

Roll cut four short lengths of 0.4 mm diameter Nickel-Silver tube (e.g. 'Albion Alloy's' NST04 or similar).

Cut a long length of 0.12 mm diameter mono-filament (e.g. 'Steelon GTM' or similar).

Secure one end of the line into the **front** pre-drilled hole in the upper surface of the tail plane trailing edge.

Slide two cut tubes onto the free end of the line.

Pass the free end of line through the **front** pre-drilled hole at the top of the fin.

Slide two cut tubes onto the free end of the line.

Pass the line through the **front** of the two pre-drilled holes in that side of the trailing edge of the tail plane.

Keep the complete line taut and secure the line in the pre-drilled hole, using CA adhesive.

Cut away the residual line as close as possible to the bottom of the tail plane.

Slide the tubes for both bracing wires against the tail plane and fin and secure in position.

Tail plane support struts:

Secure the two tail plane bracing struts in position between the fuselage and underside of the tail plane.

NOTE: The small photo-etch keel for the tail float will be fitted at the end of this build, to avoid it being broken off during the build.



NOTE: The support struts have since been painted with a metal finish.





NOTE: The support struts have since been painted with a metal finish.

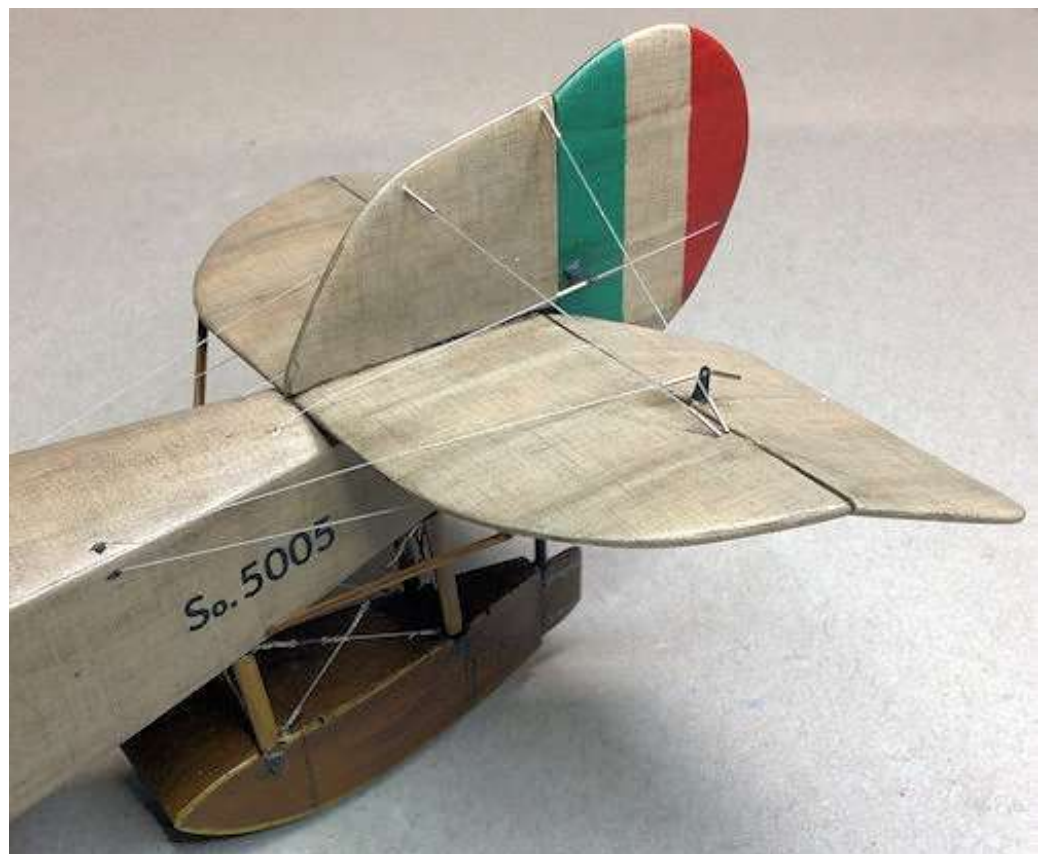

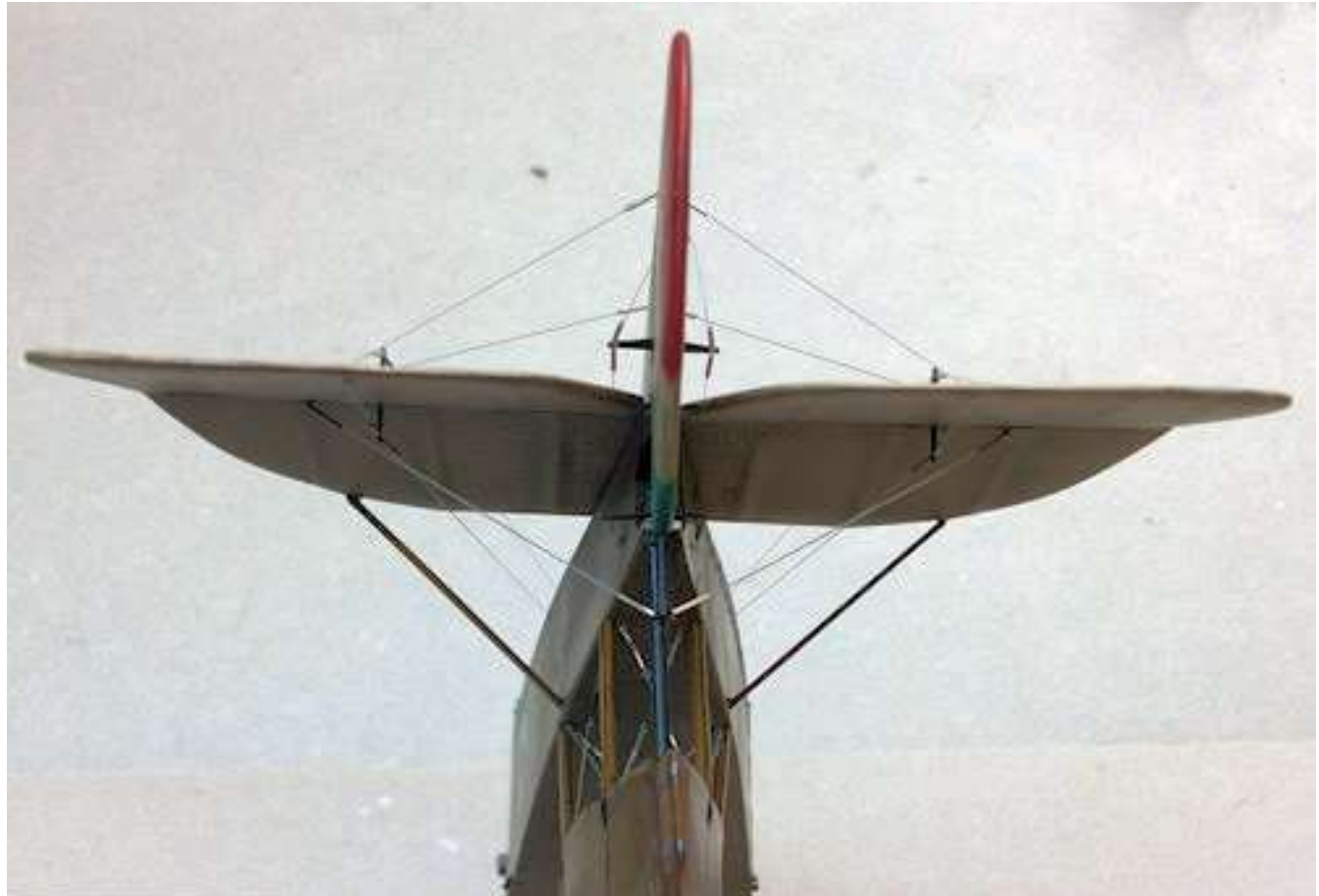
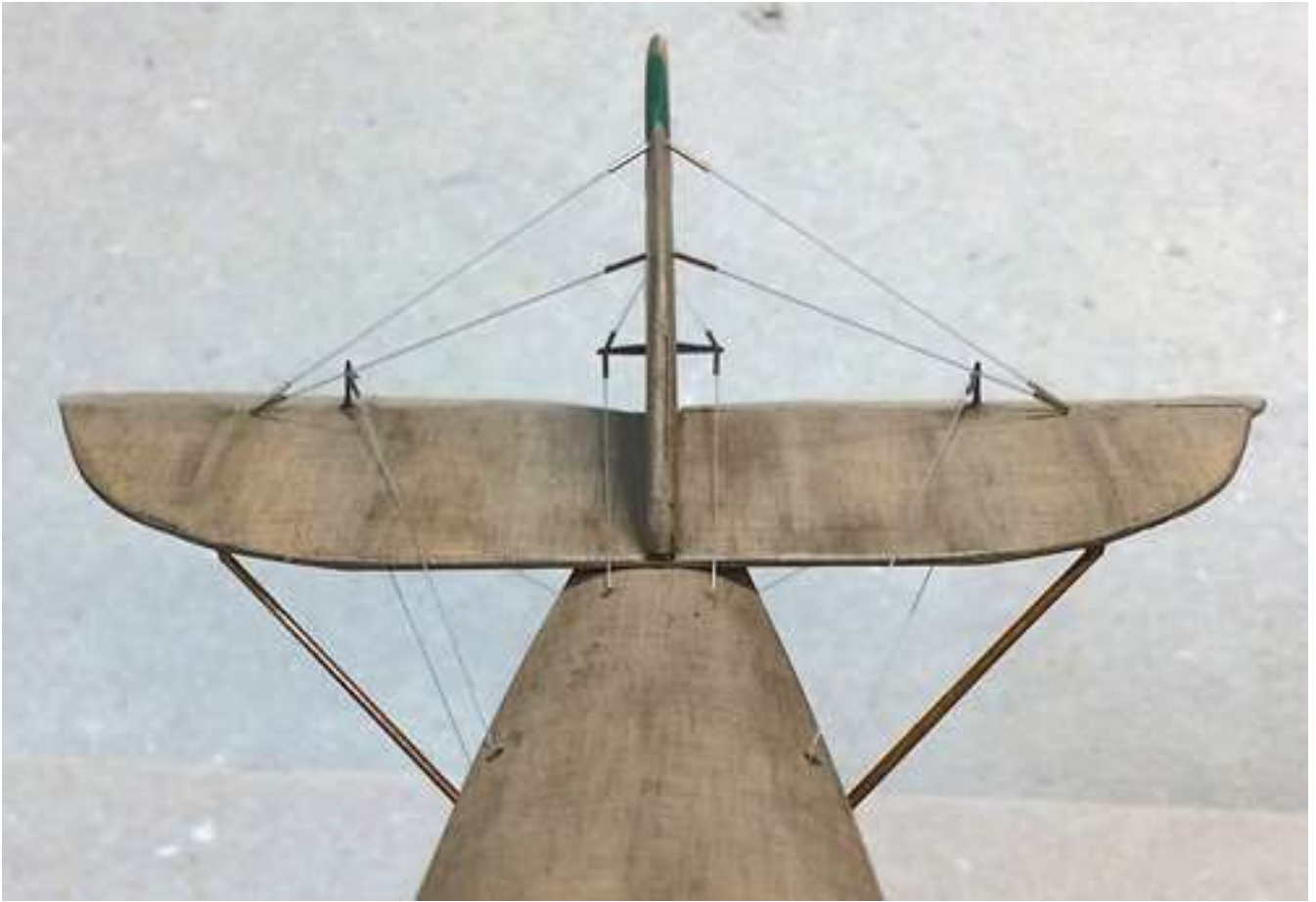

Pre-rigging:

NOTE: Before continuing with the build it is better to pre-rig the model parts as far as possible. This will make it easier to fully rig the model later in the build.

Pre-rigging requires the drilling of location holes into the model and at the various positions for attaching the rigging lines. Dependant on the particular aircraft, some will be the turnbuckles (line tensioners) and others anchor points. The following illustration annotates one side of the aircraft with where the turnbuckles and anchor points are to be fitted (duplicated on the other side of the aircraft).

Rigging for the main floats is shown, but will be covered later in this build.

NOTE: In order to achieve the correct angles for these wires, it's best to temporarily locate the outer wing and fuselage cabane struts. The front and rear flying wires are in pairs. They enter the fuselage at the metal plates, slightly above the lower wing surface and attach to the underside of the upper wing just inboard from the top of the outer wing struts.

Flying wires - fuselage:

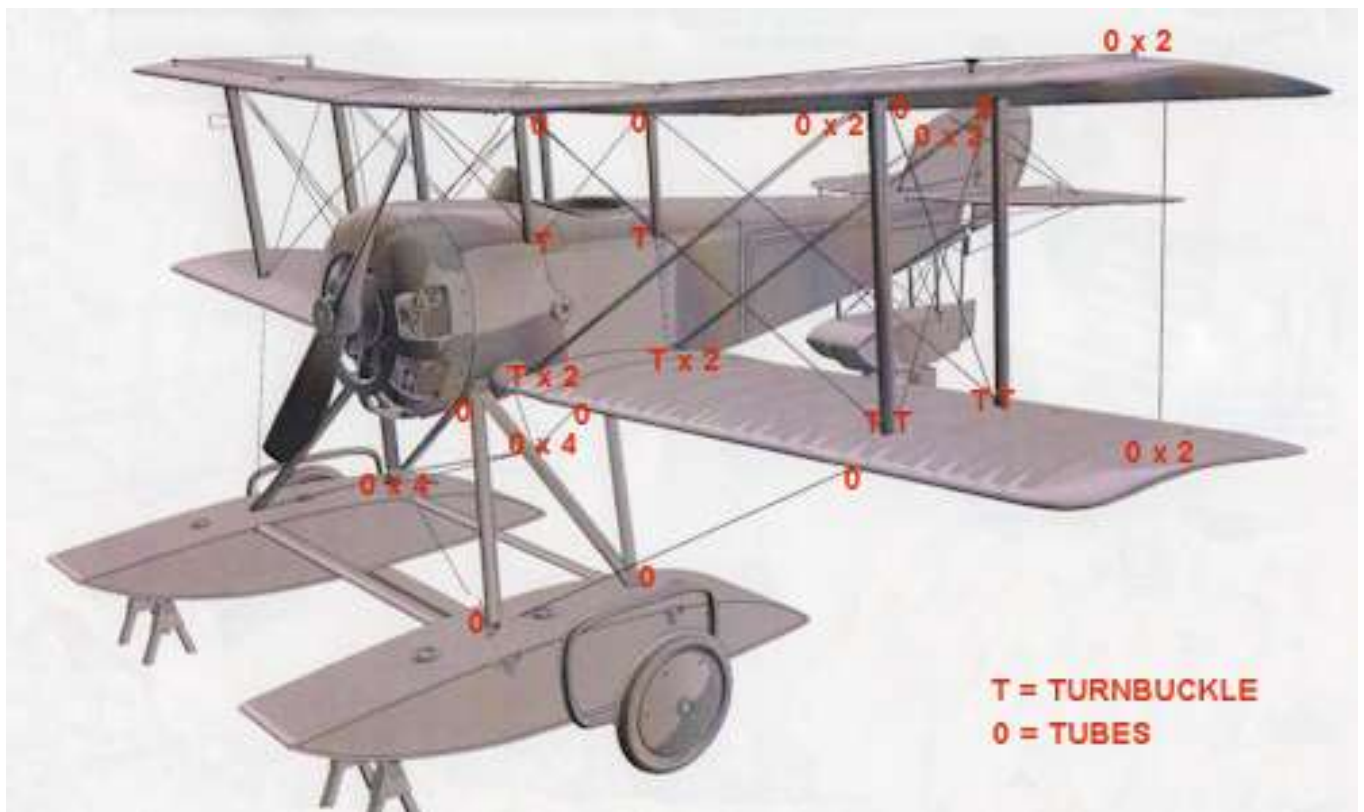

Temporarily locate the wing outer and fuselage struts into their pre-drilled location holes.

Note the angle for the wires between the metal plates on the fuselage above the wing roots and the top of the wing outer struts.

Drill two pairs of holes of 0.4 mm diameter, at the required angles, just above the lower wing roots at the metal plates.

Into each of the holes, secure a 1:48th scale 'GasPatch' turnbuckle (Type A).

Fuselage cabane struts - bracing wires:

Note the angle for the wires between the fuselage cabane struts, from the rear of the front struts and front of the rear struts, to the top of the diagonally opposite struts.

Drill a hole of 0.4 mm diameter, at the required angle, at the bottom of the two outer wing struts.

Into each of the holes, secure a 1:48th scale 'GasPatch' turnbuckle (Type A).

NOTE: *The kit instructions show crossed bracing wires between the two front cabane struts. However, These two wires were attached inboard from the top of the front cabane struts and then crossed, through an 'acorn' to the front, top of the fuselage.*

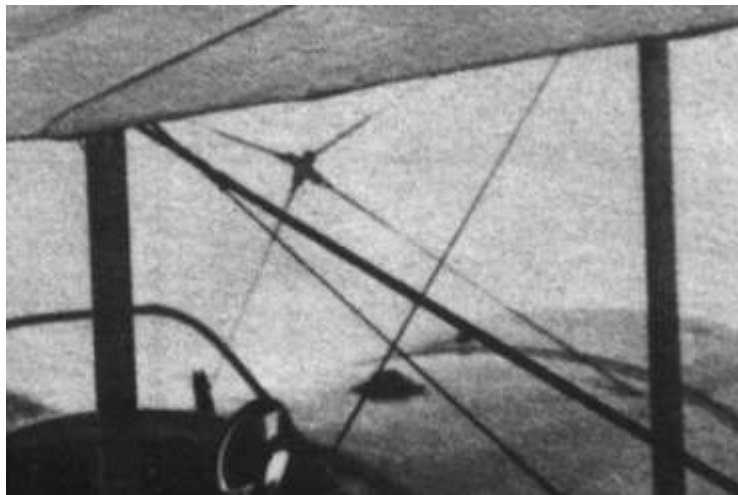

Drill a hole of 0.4 mm diameter into the top of the fuselage, 7 mm either side of the centre line and 3 mm to the rear of the engine cowl.

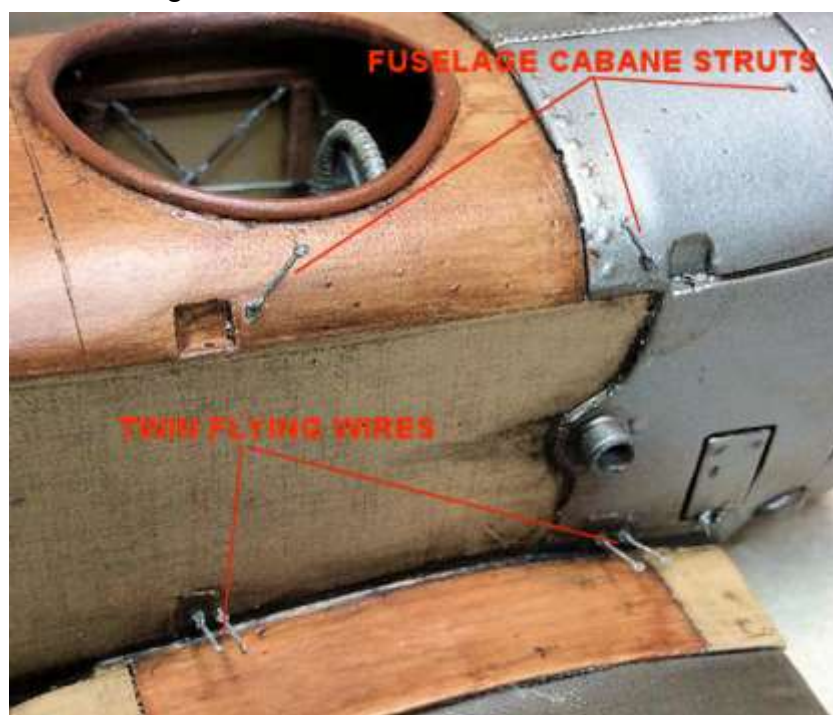

Main float - bracing wires:

On the underside of the lower wings, inboard from the wing leading edge and at the fourth wing rib in from the wing tip, drill a hole of 0.4 mm diameter into, but not through, the wing.

Into each of the holes, secure a 1:48th scale 'GasPatch' anchor point.



Landing wires - lower wings:

Note the angle for the wires between the top of the fuselage cabane struts and the bottom of the wing outer struts.

Drill holes of 0.4 mm diameter, at the required angle, just inboard from the bottom of the two wing outer struts.

Into each of the holes, secure a 1:48th scale 'GasPatch' turnbuckle (Type A).

Bracing wires - outer struts:

Note the angle for the wires between the wing outer struts, from the rear of the front struts and front of the rear struts, to the top of the diagonally opposite struts.

Drill holes of 0.4 mm diameter, at the required angle, at the bottom of the two outer wing struts.

Into each of the holes, secure a 1:48th scale 'GasPatch' turnbuckle (Type A).

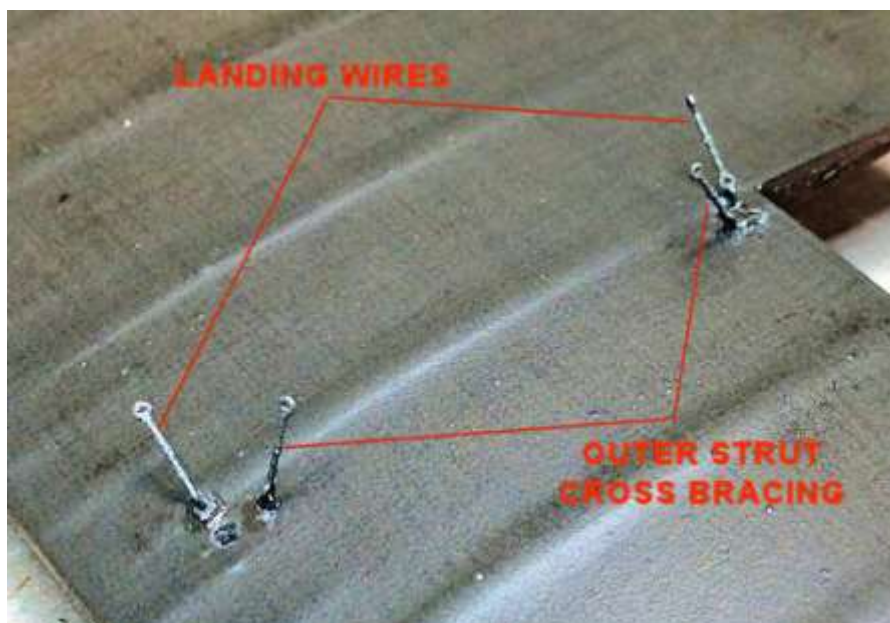

Flying wires - upper wings:

Note the angle for the wires between the top of the wing outer struts and the fitted turnbuckles in the fuselage at the lower wing roots.

Drill a pair of holes of 0.4 mm diameter into the underside of the upper wing, at the required angle, just inboard from the strut locations holes.

Into each of the holes, secure a 1:48th scale 'GasPatch' anchor point.

Landing wires - upper wings:

Note the angle for the wires between the bottom of the wing outer struts and the top of the fuselage cabane struts.

Drill holes of 0.4 mm diameter into the underside of the upper wing, at the required angle, just inboard from the strut locations holes.

Into each of the holes, secure a 1:48th scale 'GasPatch' anchor point.

Bracing wires - outer struts:

Note the angle for the crossed wires between the bottom and the top of the wing outer struts.

Drill holes of 0.4 mm diameter into the underside of the upper wing, at the required angle, just rear of the front strut and front of the rear strut.

Into each of the holes, secure a 1:48th scale 'GasPatch' anchor point.

Fuselage cabane struts - bracing wires:

Note the angle for the crossed wires between the bottom and the top of the fuselage cabane struts.

Drill holes of 0.4 mm diameter into the underside of the upper wing, at the required angle, just rear of the front strut and front of the rear strut.

Into each of the holes, secure a 1:48th scale 'GasPatch' anchor point.

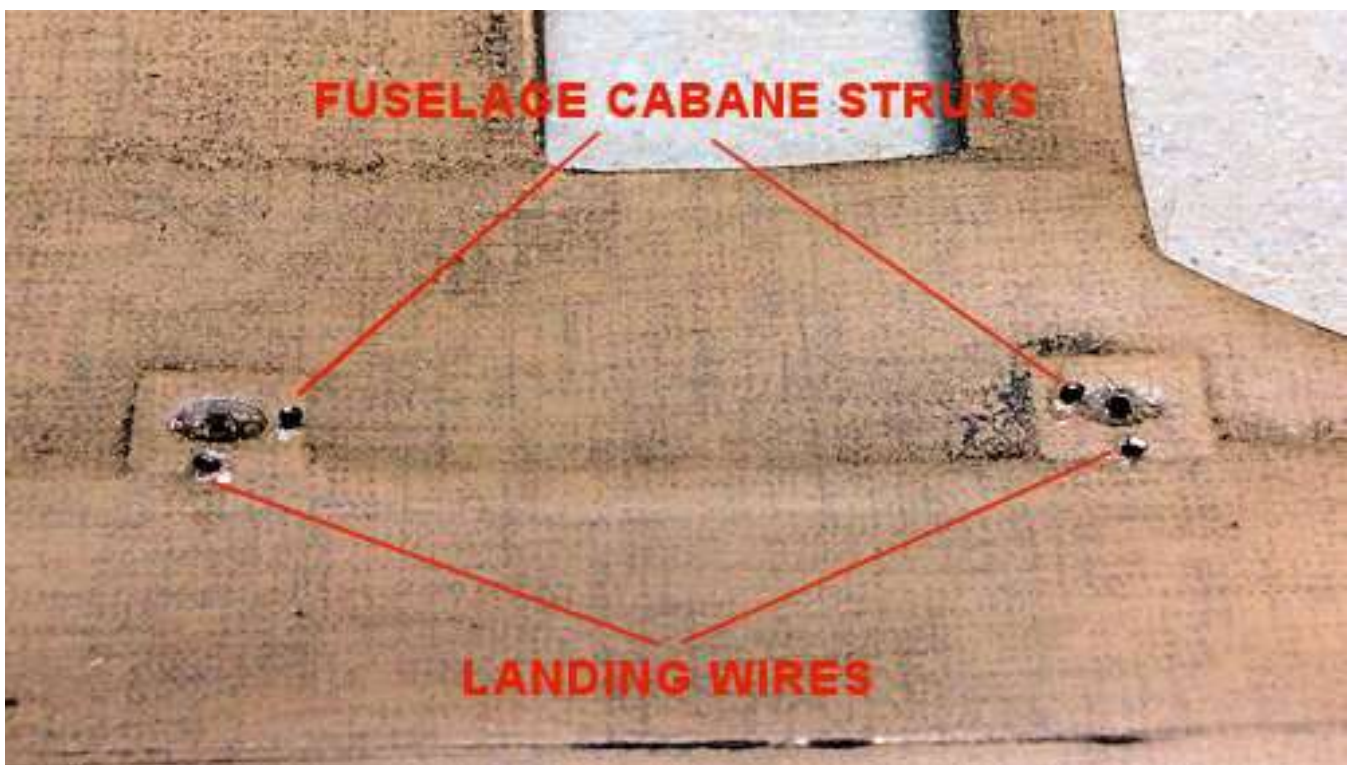

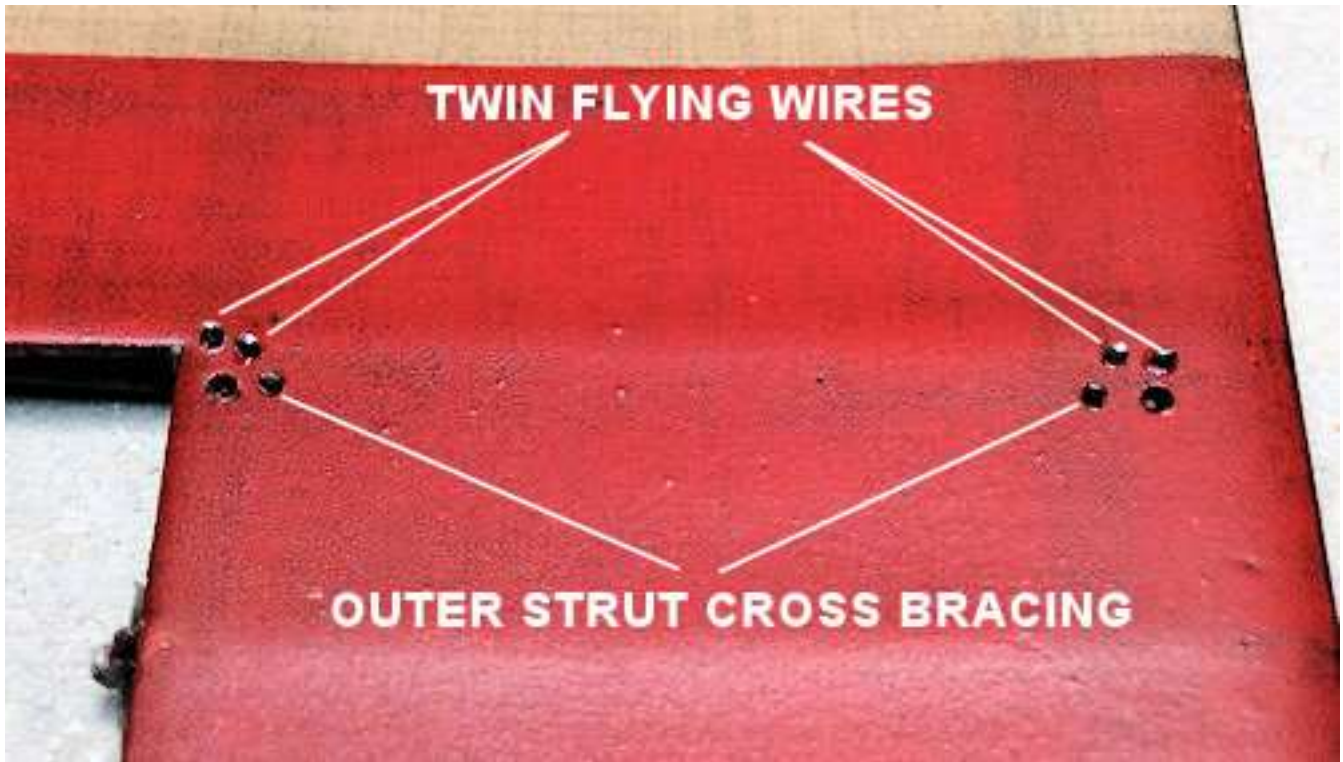

NOTE: *Rigging of the main floats and wing ailerons will be carried out later in this build.*

Painting (cont'd):

Brush paint the centre section of each turnbuckle with 'Tamiya' Hull red (XF9) or similar.

Brush paint the pre-moulded 'metal' plates at the ends on each of the for wing outer support struts with 'Mr. Colour' Stainless Steel (213) or similar.

Brush paint the two pre-moulded 'metal' bands around both main float support struts with 'Mr. Colour' Stainless Steel (213) or similar.

Windscreen:

NOTE: *At this stage of the build it is best to fit the windscreen, as access to that area will be restricted once the upper wing is fitted.*

Remove the photo-etch windscreen from the supplied sheet and file or sand away any residual 'tags' from the outer edges.

Anneal (soften) the windscreen frame by applying heat across the frame from for example, a cigarette lighter. Apply the heat in a constant movement until the photo-etch discolours.

Wipe the surfaces of the frame then lightly sand to provide a keying surface for painting.

Carefully bend the frame over a curved surface so it conforms to the contour of the top of the fuselage, forward from the cockpit. I used a bottle of 'AK Interactive' paint as the former (approximately 25 mm in diameter).

Prepare the frame for painting by brushing it with 'VMS' Metal Prep 4K.

Airbrush the frame with a light coat of 'Alclad' Gloss Black Base (ALC-305-60) or similar.

Airbrush the frame with a light coat of 'Alclad' Duraluminium (ALC-102) or similar.

Remove the supplied windscreen self adhesive template from the sheet and apply it onto the supplied acetate sheet.

Carefully cut around the template to create the shape of the windscreen.

Remove the template from the acetate windscreen.

Position the acetate windscreen on the inner curved surface (cockpit side) and clamp in position, using fine pointed tweezers.

Apply 'MicroScale' Micro Krystal Clear adhesive (or similar PVA adhesive) around the edges of the acetate and the frame.

Once fully set, release the tweezers.

Apply 'MicroScale' Micro Krystal Clear adhesive (or similar PVA adhesive) along the bottom edge of the windscreen assembly and position it onto the fuselage, forward from the cockpit.



Upper wing - pre-rigging:

NOTE: *The following procedure should be carried out on all of the anchor points and turnbuckles fitted to the underside of the upper wing. The anchor points for the front fuselage cabane struts require two pre-rigged lines each.*

Cut a long length of 'Steelon' Mono-Filament 0.12 mm diameter or similar.

Cut a short length of 0.5 mm diameter tube ('Albion Alloy's MBT05 or similar).

Pass the line through the cut tube then through the eye end of an anchor point.

Loop the line back through the tube.

Slide the tube up to, but not touching, the eye end.

Secure the tube to the lines.

Cut away the exposed excess line tag.

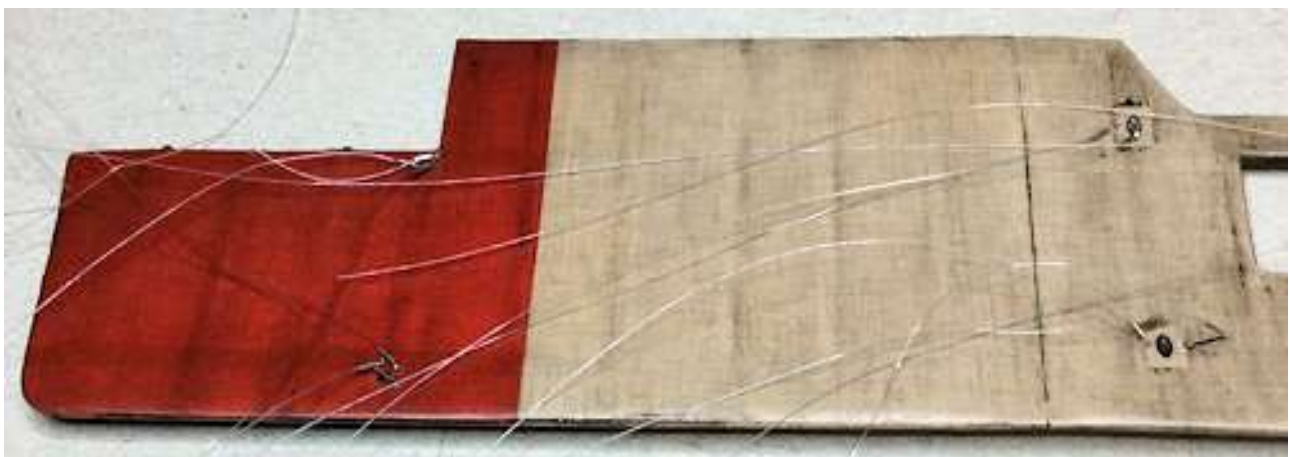

Upper wing - fitting:

Scrape away any paint or primer from the end locating rods of the wing outer and fuselage cabane struts.

Make sure all decal, paint or primer are cleared from the wing outer and fuselage cabane strut location holes in the wing and fuselage.

Use masking tape to secure the rigging wires clear of the strut location holes on the underside of the upper wing.

Apply CA thin CA adhesive to an end locating rod on the wing outer struts.

NOTE: *During the following step, make sure the wing outer struts are fitted with a slight tilt forwards at the top of the struts.*

Locate the struts into their locating holes in the lower wings.

Apply CA thin CA adhesive to an end locating rod on the fuselage cabane struts.

NOTE: *During the following step, make sure the wing outer struts are fitted with vertical to the fuselage.*

Locate the struts into their locating holes in the fuselage.

Lay the upper wing down on the work surface with the rigging lines clear of the strut locating holes.

Holding the model upside down, carefully locate each of the struts into their wing and fuselage locating holes.

Check the upper wing is slightly forward from the lower wings and is parallel to the lower wings when viewed from above and at the same angle when viewed from the sides.

Carefully apply thin CA adhesive the strut location at the upper wing.

Remove the masking tape to release the rigging lines.

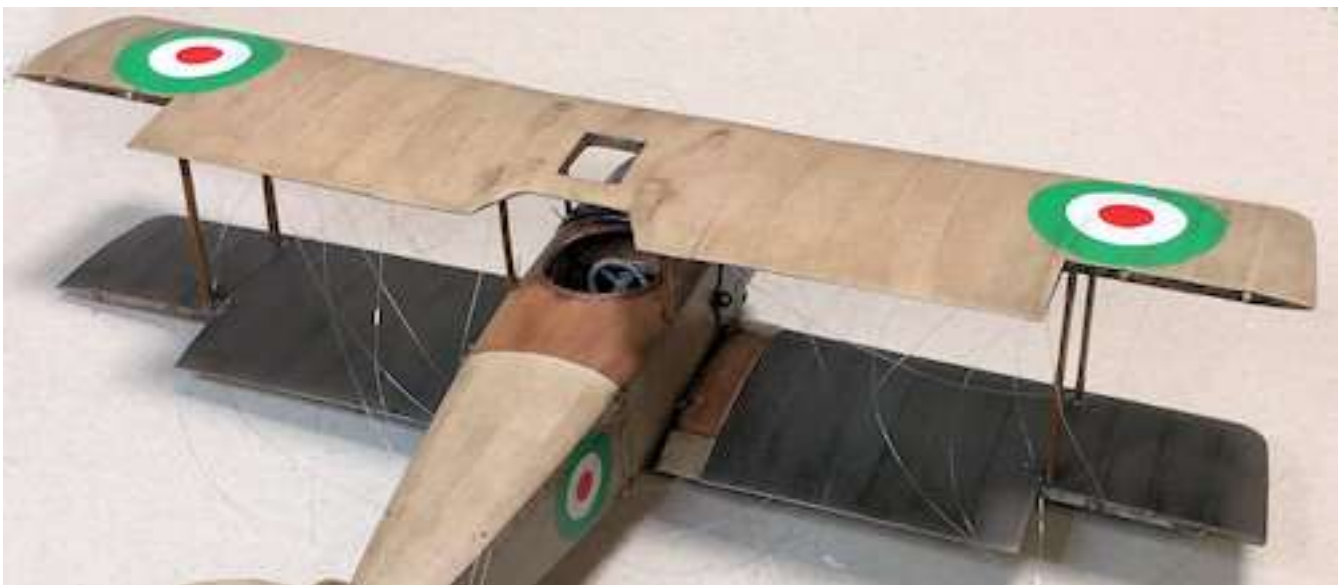

Wings - final rigging:

NOTE 1: *The following procedure should be carried out on all of the anchor points/turnbuckles fitted to the lower wings and fuselage.*

NOTE 2: *The order of rigging the various lines for the wings should be in the correct sequence, to enable the best access to the lines.*

Order of rigging:

1. Fuselage cabane struts, between front and rear struts.
2. Outer wing struts, between front and rear struts.
3. Twin flying wires (front and rear), between upper wing and fuselage.
4. Single landing wires (front and rear), between lower wing and top of fuselage cabane struts.

Pass the free end of the line through a cut tube then through the eye end the relevant turnbuckle or anchor point.

Loop the line back through the tube.

Keeping the line taut, slide the tube up to, but not touching, the eye end of the turnbuckle or the anchor point.

Secure the tube to the lines.

Cut away the exposed excess line tag.

5. Fuselage cabane struts, between front struts and top of fuselage.

Cut a short length of 2 m plastic rod and sand one end to a rounded profile.

Drill a hole of 0.3 mm diameter horizontally across the rod to the rear of the rounded end.

Pass the pre-fitted rigging line from the left front cabane strut anchor, through the pre-drilled hole in the rod, from the left side.

Pass the pre-fitted rigging line from the right front cabane strut anchor, through the pre-drilled hole in the rod, from the right side.

Hold the free ends of the two lines with self-locking tweezers (to keep the lines taut).

Move the rod up and central between the two front cabane struts.

Secure the lines to the rod using thin CA adhesive.

Pass each of the free ends of the lines into the pre-drilled holes in the top of the fuselage (rear of the engine cowl join).

Keep each line taut and secure in its hole using thin CA adhesive.

Brush paint the rod only with 'Tamiya' Flat Earth (XF52).

NOTE: *During the following step, take care not to touch the line or model parts with the heat source or the line will melt and break or the model part will be melted. Always keep the heat source moving along the line.*

Once rigging is complete, any lines that are slack can be tightened by carefully moving a heat source, such as a small electricians soldering iron, along the line. This will shrink the line and tighten it.

NOTE: *The upper and lower ailerons will be fitted and rigged after the main floats have been fitted. This will avoid damaging the ailerons or their control rigging when handling the model.*

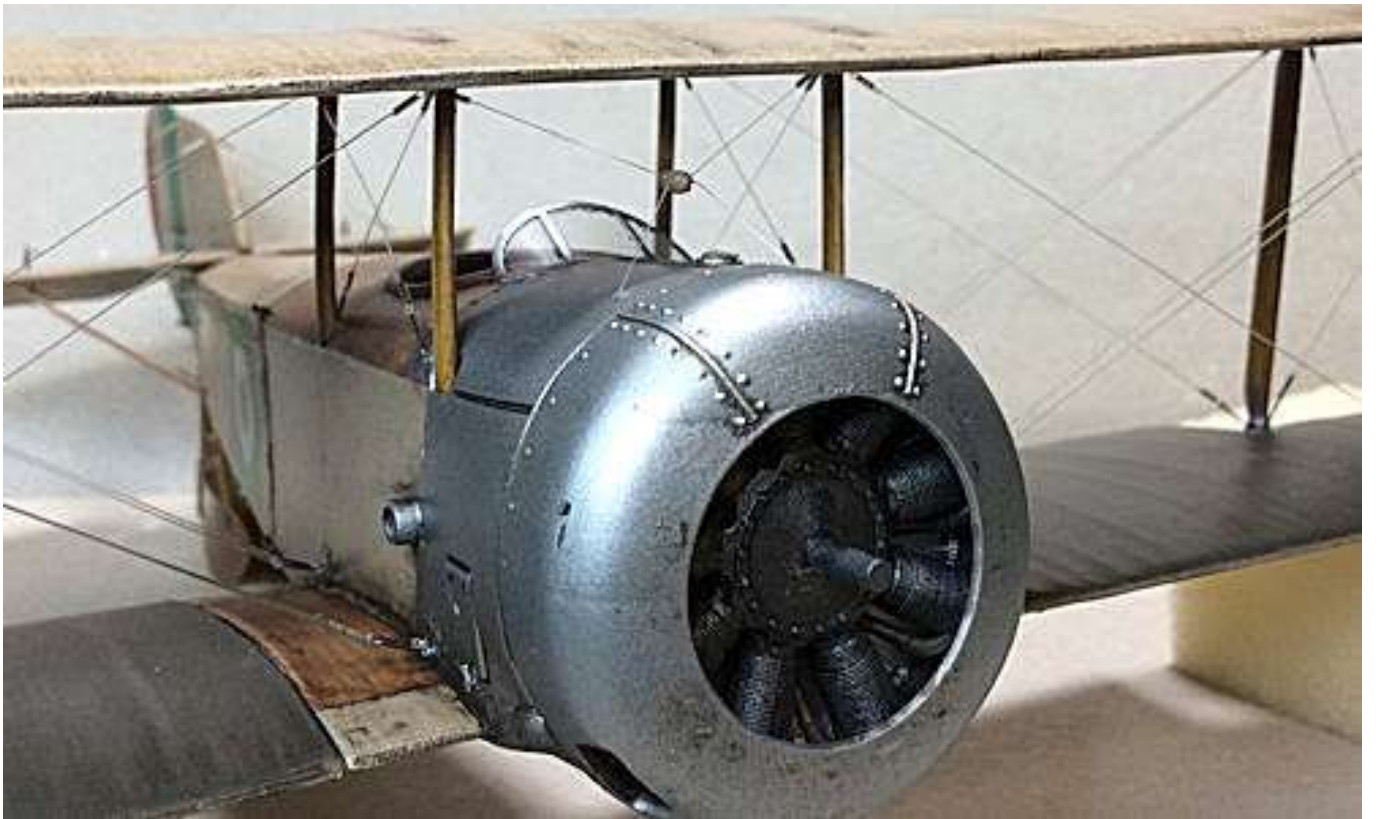

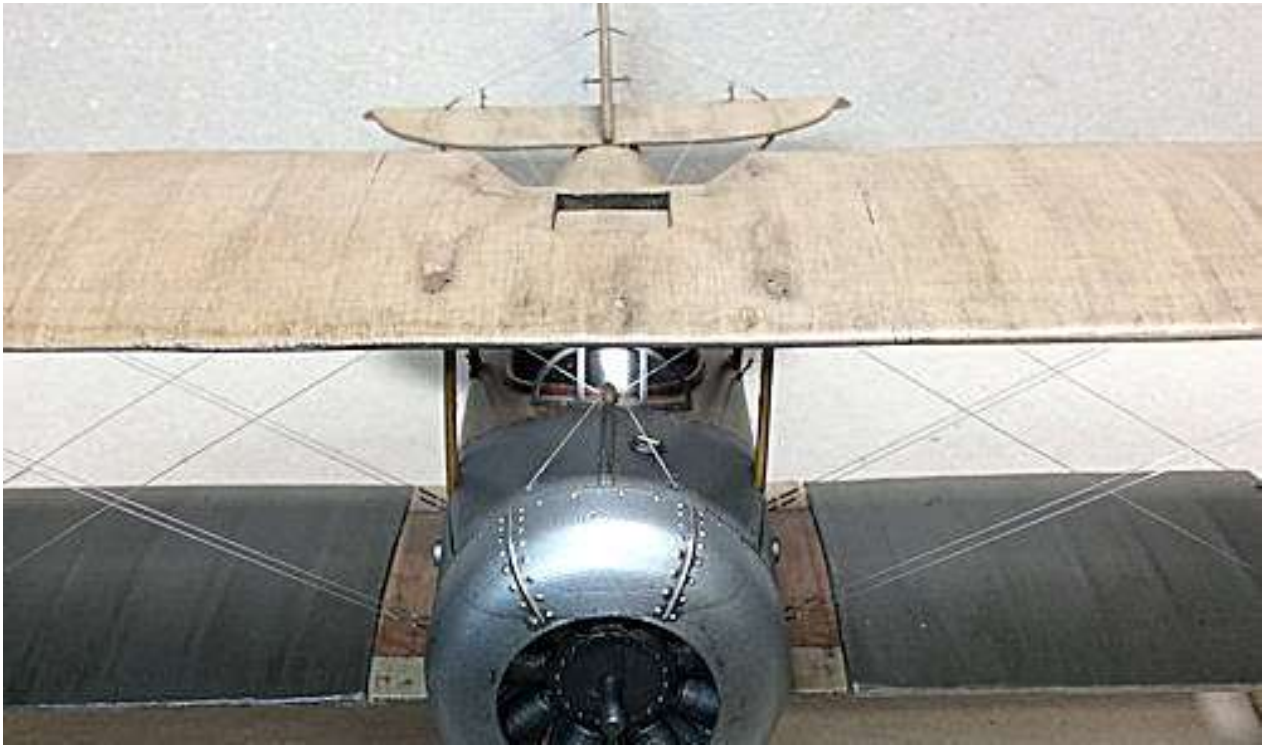

Main floats:

NOTE: Now that the wings have been fitted and rigged, the model can be turned upside down so that its main floats can be fitted and rigged. As can be seen in the following photograph, the two main floats are attached to the fuselage by 'N' struts and to each other by two cross members. The rigging required is from the bottom of the forward 'N' struts out to the underside of the lower wings and cross bracing between the top and bottom of the forward and the rear 'N' struts.

Make sure the pre-drilled holes in the main floats for locating the float 'N' struts and the two cross members are clear of any paint. If necessary, use a 0.9 mm diameter drill to clear out the holes.

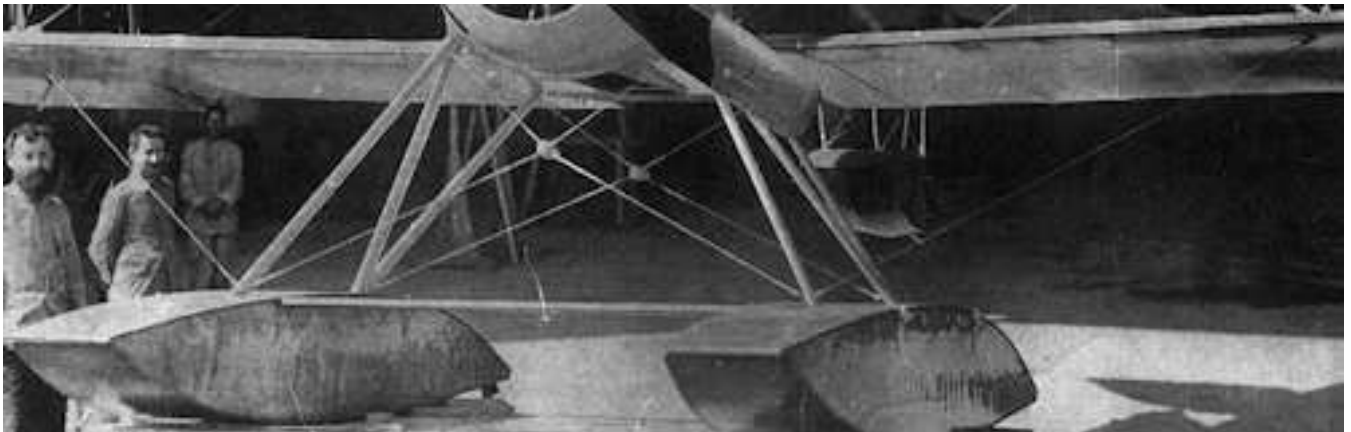

Test fit the 'N' struts into their float location holes. Make sure the struts are inserted the correct way around (the two 'banded' struts at the top for the front fuselage locations).

NOTE: During the next step, make sure the holes are drilled at the correct angle to accept the 'N' struts when fitted to the main floats.

Drill holes of 0.9 mm diameter into the fuselage locations for the top of the 'N' struts. The rear locations are moulded into the bottom, outer edges of the fuselage. The front locations are at the 'bulges' at the bottom, front of the fuselage.

Test fit the 'N' struts and cross members into the main floats and fuselage locations. Make sure the floats are correctly positioned when viewed from above and from the sides.

NOTE: *The following step is to provide a location hole for the strut bracing, fitted later in this build.*

Drill a hole of 0.6 mm diameter into the top, outer face of the forward strut, just above the band around the strut. Make sure you don't drill through the strut.

Secure the 'N' struts into the main floats.

Secure the two cross members into the main floats.

Remove the photo-etch plates (kit parts 9, 10, 11 and 12) from the kit supplied sheet.

Remove any residual tags from the edges of the plates.

Secure the plates 9 to the top, outer side of the front struts and 10 to the top of the outer side of the rear struts.

Secure the plates 11 to the bottom, outer side of the front struts and 12 to the bottom, outer side of the rear struts.

Brush paint the plates with 'Mr. Colour' Stainless Steel (213 to blend them with the colour painted on the 'N' struts.

NOTE: *The bracing wires from the underside of the wings should pass through the bottom of the main float front struts. However as the struts have metal reinforcing rods, drilling through the struts is not practicable. Therefore I chose instead to have anchor points inserted into the top of the floats.*

Drill a hole of 0.4 mm diameter into the top of the two main floats, just to the rear of the rear strut locations and just forward from the front strut locations.

Drill a hole of 0.4 mm diameter into the underside of the fuselage, just forward from the rear strut locations and just to the rear of the front strut locations.

Secure a 'GasPatch' 1:48th scale anchor point into each of the pre-drilled holes.

Roll cut four short lengths of 0.5 mm diameter tube (e.g. 'Albion Alloy's' MBT05 or similar).

Cut four long lengths of 'Steelon' 0.12 mm diameter mono-filament or similar. Two of the lengths to be approximately 12 inches long.

NOTE: *The following step should be carried out on each of the fuselage anchor points. The two longest lengths of line are for the fuselage front anchor points.*

Pass a line through a cut tube then through the eye of the anchor point.

Loop the line back through the tube.

Move the up to, but not touching, the eye of the anchor point.

Secure the tube to the lines.

Cut away the exposed residual line leaving the long line attached to the tube.

Move the four installed lines clear of the four 'N' strut location holes in the fuselage.

Secure the struts of the main float 'N' struts into their location holes. Make sure the floats are correctly positioned when viewed from above and from the sides.

Detach the two cross bracing 'acorns' (kit part A and B) from their sprue and scrape away the sprue tag.

At the outer end of the groove on each 'acorn', drill a hole of 0.3 mm diameter diagonally through the 'acorns' (for the bracing lines).

NOTE: *The kit instructions show a 0.5 mm diameter rod between the two 'acorns' of the cross bracing wires for the two main floats. However, photographs and drawings of both the Sopwith and the Ansaldo 'Baby' aircraft, including museum examples, have no such bar between the bracing wires. Only the colour profiles in the kit instructions and in Windsock Mini Date file No.15 - Ansaldo Baby (by Gregory Alegi) show this bar. Therefore I chose to disregard that part.*

Roll cut four short lengths of 0.5 mm diameter tube (e.g. 'Albion Alloy's' MBT05 or similar).

Roll cut ten short lengths of 0.4 mm diameter tube (e.g. 'Albion Alloy's' NST04 or similar).

Floats - rear bracing:

NOTE: *The following procedure should be carried out for both bracing lines.*

Pass the free end of the line through a 0.4 mm diameter tube.

Pass the line diagonally through the pre-drilled hole in that top side of the 'acorn' (groove facing downwards).

Pass the free end of the line through a 0.4 mm diameter tube.

Pass the free end of the line through a 0.5 mm diameter tube.

Pass the free end of the line through the eye end of the anchor point in the opposite main float.

Loop the line back through the 0.5 mm tube.

Keeping the line semi-taut, slide the 0.5 mm tube up to, but not touching, the eye end of the anchor point.

NOTE: *During the next step, if necessary, slightly release the tension in the lines, to allow the 'acorn' to be positioned.*

Position the 'acorn' centrally between the struts and between the fuselage and the floats.

Secure the 'acorn' to the lines.

If necessary, keep the line taut and re-position the 0.5 mm tube up to, but not touching, the eye end of the anchor point.

Keeping the 0.4 mm tubes clear, secure the tube to the line.

Cut away the exposed residual line from the tube.

Slide the four 0.4 mm tubes up to the 'acorn' and secure in position.

Floats - front bracing:

NOTE: *The following procedure should be carried out for both bracing lines.*

Pass the free end of the line through a 0.4 mm diameter tube.

Pass the line diagonally through the pre-drilled hole in that top side of the 'acorn' (groove facing downwards).

Pass the free end of the line through a 0.4 mm diameter tube.

Pass the line through the eye end of the front anchor point in the opposite main float.

Pass the free end of the line through a 0.4 mm diameter tube.

Pass the free end of the line through a 0.5 mm diameter tube.

Pass the free end of the line through the eye end of the anchor point in the underside, leading edge of the lower wing.

Loop the line back through the 0.5 mm tube.

Keeping the line taut, slide the 0.5 mm tube up to, but not touching, the eye end of the anchor point.

NOTE: *During the next step, if necessary, slightly release the tension in the lines, to allow the 'acorn' to be positioned.*

Position the 'acorn' centrally between the struts and between the fuselage and the floats.

Secure the 'acorn' to the lines.

If necessary, keep the line taut and re-position the 0.5 mm tube up to, but not touching, the eye end of the anchor point.

Keeping the 0.4 mm tubes clear, secure the tube to the line.

Cut away the exposed residual line from the tube.

Slide the four 0.4 mm tubes up to the 'acorn' and secure in position.

Slide the two 0.4 mm tubes up to the bottom of the front strut and secure in position.

Brush paint the two 'acorns' with 'Tamia' Rubber Black (XF85) or similar.



Ailerons - attachments:

NOTE: *At this late stage of the build, I decided to modify the way the ailerons are attached to the wings. The kit pre-moulded lugs on the wings and slots in the ailerons may not provide a strong enough joint when rigging is applied. Make sure the wings are supported while re-working the attachments is carried out.*

Cut away then sand the two attachment lugs on each wing aileron location. Leave enough to provide a 'witness' mark of the lug.

Point mark the centre of each aileron 'witness' mark.

Using the point marks as a guide, drill holes of 0.5 mm diameter into the wings.

Drill holes of 0.5 mm diameter into the ailerons at the centre of each location cut-out.

Snip cut lengths of 0.5 mm diameter brass rod (e.g. 'Albion Alloy's' or similar).

Secure the cut rods into the pre-drilled holes in the ailerons.

Dry fit each aileron into its pre-drilled holes in the wings.

If you desire the ailerons to be 'animated', carefully bend the ailerons on one side of the wings either slightly up or down. Make sure the ailerons are bent to the same angle. Repeat for the ailerons on the opposite wings, but bend them in the opposite direction and at the same angle. That is left ailerons up, right ailerons down.

Remove the ailerons for pre-rigging.

Ailerons - pre-rigging:

NOTE: *The following procedure should be carried out to pre-rig the various lines to the four Ailerons.*

Cut a long length of 'Stroft GTM' 0.08 mono-filament or similar.

Cut a short length of 0.4 mm diameter tube ('Albion Alloy's NST04 or similar).

Pass the line through the cut tube then through the hole at the top of the aileron control horn.

Loop the line back through the tube.

Slide the tube up to, but not touching, the eye end.

Secure the tube to the lines.

Cut away the exposed excess line tag.

Lower left aileron:

Using the above procedure, add a rigging line of approximately 3 inches length to face forwards from the control horn.

Add a rigging line of approximately 6 inches length to face rearwards from the control horn. Then pass the free end of the line through the pre-drilled hole at the rear of the aileron.

Lower right aileron:

Using the above procedure, add a rigging line of approximately 3 inches length to face forwards from the control horn.

Add a rigging line of approximately 6 inches length to face rearwards from the control horn. Then pass the free end of the line through the pre-drilled hole at the rear of the aileron.

Upper left and right ailerons:

Using the above procedure, add a rigging line of approximately 12 inches length to face forwards from the control horn.

Ailerons - fitting:

Pull out each aileron far enough to be able to apply CA adhesive to the locating rods.

Make sure the pre-installed rigging lines are not trapped between the wings and ailerons.
Apply CA adhesive to the exposed locating rods then push the ailerons fully back to the wings.

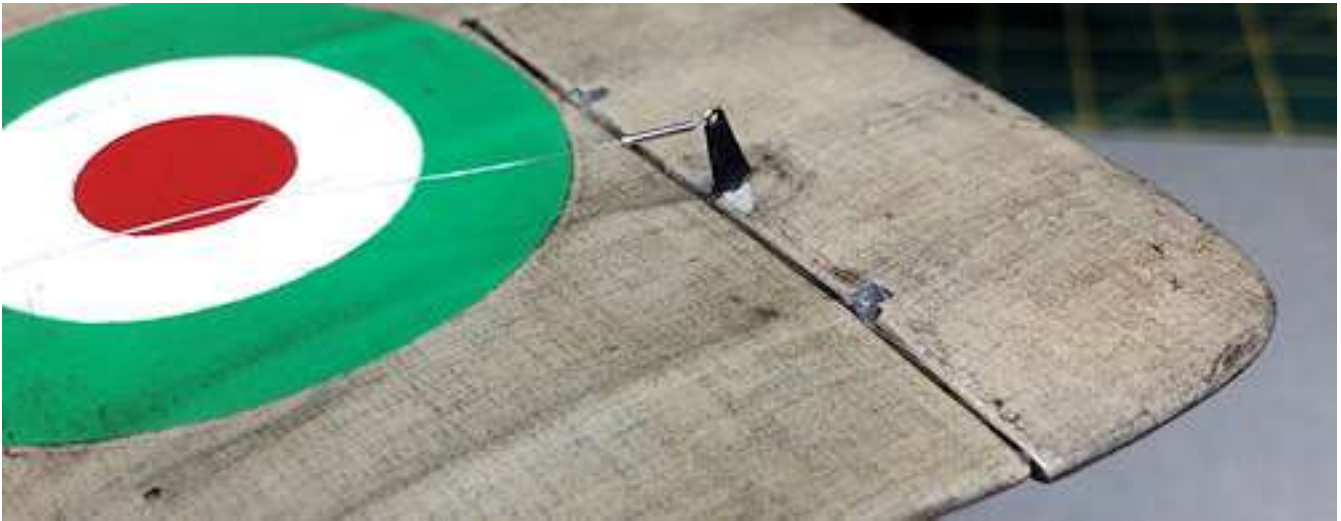

Ailerons - final rigging:

NOTE: *The two pulleys for the over wing control wire are supplied as resin casts and may not be strong enough to take the tension of the rigging. Therefore I decided to replace the pulleys with plastic card and metal rod.*

Cut four discs of 2 mm diameter from 0.2 mm thick plastic card.

Cut two discs of 1.5 mm diameter from 0.2 mm thick plastic card.

Cement a 1.5 mm disc between two of the 2 mm discs, and repeat to create two pulleys.

Drill a hole of 0.8 mm through the centre of each pulley.

Snip cut two short lengths of 0.8 mm diameter rod (e.g. 'Albion Alloy's' or similar).

Secure each rod into a pulley hole, making sure the end of the rod is flush with one side of the pulley.

Prime the pulleys with a grey primer ('AK Interactive grey AK-758 or similar).

Brush paint the pulleys with 'Mr. Colour' Stainless Steel (213) or similar.



Snip cut the rods away to leave 1 mm of rod attached to the pulleys.

Secure the rods into the pre-drilled 0.8 mm holes in the top, outer surface of the upper wing to leave just the pulleys exposed.

NOTE: *The instructions show two photo-etch 'lifting points' located either side of the wing centre section along the leading edge. I believe were intended to represent guides for the aileron control wire. I chose to replace the photo-etch 'guides' to be more in-scale.*

Make sure the two pre-drilled 0.5 mm diameter holes for the cable guides are clear of paint. If necessary use a 0.5 mm diameter drill to clean out the holes (don't drill through the wing).

Secure a 'GasPatch' **1:32 scale** anchor point into each of the pre-drilled holes. The anchor points should be inline with the fuselage (to allow the control line to pass through).

On the underside of the lower wings, cut the forward aileron control lines so that they can be kept taut and inserted into the pre-drilled holes towards the leading edge of the wings.

Secure the lines into the holes.

Pass the free ends of the two rear lines (already through the aileron rears) up and through the pre-drilled hole in the upper wing ailerons.

Slide a roll cut 0.4 mm diameter tube ('Albion Alloy's' NST04 or similar) onto the free end of the lines.

Pass the free end of the lines through the hole in the aileron control horns.

Pass the lines back through the tubes.

Keep the lines taut, slide the tubes up to, but not touching, the control horns.

Secure the tubes to the lines.

Cut away the exposed residual lines.

Route the long aileron lines (pre-rigged on the upper aileron control horns) forwards and around the installed aileron pulley.

Pass the line through the eye ends of the two installed anchor points.

Slide a roll cut tube of 0.4 mm diameter (e.g. 'Albion Alloy's' NST04 or similar) onto the lines.

Pass one line through the eye end of a 'Gaspatch' turnbuckle (Type C).

Loop the line back through the tube but leave the line slack.

Repeat to the opposite end of the turnbuckle.

NOTE: *During the following steps, make sure the lines are correctly routed around both of the aileron control pulleys.*

Keeping the lines taut, position the turnbuckle centrally between the two cable guides (anchor points).

Slide one tube up to, but not touching, the turnbuckle.

Secure the tube to the lines.

Keeping the lines taut, slide the other tube up to, but not touching, the turnbuckle.

Secure the tube to the lines.

Cut away the exposed residual line at the tube.

Brush paint the centre section of the turnbuckle with 'Tamiya' Hull Red (XF9) or similar.



Lifting points:

Secure the four lifting points (kit photo-etch parts 16) into the pre-drilled holes in the centre section of the top of the upper wing. The lifting points should be in line with the fuselage.

Rear float - keel:

Secure the photo-etch keel (kit photo-etch part 8) to the bottom, rear centre of the rear float.

Brush paint the keel with 'Tamiya' Rubber Black (XF85) or similar.

Strut bracing bars:

NOTE: *The kit instructions show a 0.5 mm diameter rod to be attached across the top of the front struts of the main float gear. However, this bracing bar or step was not a straight bar, but instead was formed in a 'U' shape, as can be seen in the following photograph. I chose to make these two parts from 0.5 mm diameter lead wire.*



Cur two lengths of 0.5 mm diameter lead wire (e.g. 'PlusModel' or similar).

Insert one end of a wire into the pre-drilled 0.6 mm diameter in the top of the forward strut.

Secure the wire in position using CA adhesive.

Carefully bend the wire to form the shape in the photograph above.

Trim the free end of the wire so it rests against the rear strut.

Secure the wire to the rear strut using CA adhesive.

Brush paint wires with 'Mr. Colour' Stainless Steel (213) or similar.



Attitude indicator:

NOTE: *The kit photo-etch part 29 represents the attitude indicator. However, the kit instructions are incorrect as they show the indicator fitted the wrong way around and attached to the left outer, forward wing strut. As can be seen in the following photograph and drawing, the indicator was fitted with the curved end facing rearwards. Also most photographs show the indicator being fitted the right, forward cabane strut, which would be more visible to the pilot than if it was mounted to the outer wing struts. I believe 'Lukgraph' possibly mistook the indicator for pitot tubes, hence the errors.*

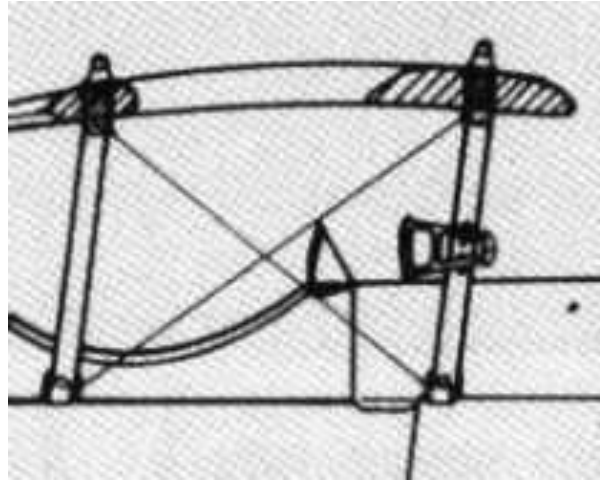
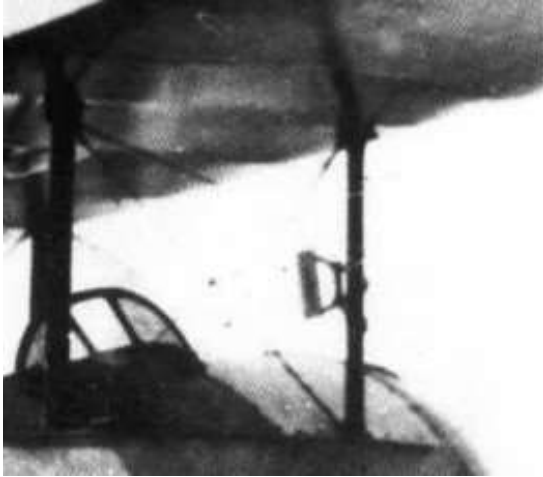

Remove the attitude indicator from the kit supplied photo-etch sheet.

Brush paint the indicator with 'Mr. Colour' Stainless Steel (213) or similar, except for the curved end (leave as photo-etch).

Secure the attitude indicator, curved end facing rearwards, to the outside surface of the forward, right cabane strut. The front of the indicator should protrude slightly from the strut.

Pilot's step:

Dill out the pre-mould location for the pilot's step, in the underside, left of the fuselage, using a 1.0 mm diameter drill.

Secure the resin pilot's step into the holes.

Brush paint the step with 'Mr. Colour' Stainless Steel (213) or similar.

Rigging:

Cover the windscreen to protect it from over spray. I used 'Humbrol' Maskol, which can easily be peeled away after it has dried.

Airbrush all of the rigging with a light coat of semi-matte, such as 'Alclad' Light Sheen ALC-311 or 'Tamiya' Semi-clear X35 or similar.

Uncover the wind screen.

Propeller - fit:

Locate the propeller onto the engine propeller shaft and at the desired angle and with the rear propeller boss in-line with the front of the engine cowl (when viewed from the side or top).

Secure the propeller in position, using CA adhesive.

PART 14

FIGURE

PART 14 - FIGURE

The figure I chose to use is the 'Kellerkind' Gotha bomber pilot (54095).

NOTE: *The figures are made of resin (refer to Part 5 [Resin] of this build log). Due to the position of the two arms on the assembled figure, painting once assembled will be difficult. Therefore the arms will be painted before being attached to the figure.*

Preparation:

Removed the figure parts from their moulding blocks.

File or sand away residual mounting bloc resin from the parts.

Check that there are no surface imperfections and if necessary, fill and/or sand to restore the surface finish.

Painting:

Airbrush prime the figure parts with a grey primer, such as 'AK Interactive' Grey (AK-758) or similar.

NOTE: *The figure was painted using 'AK Interactive' and 'Tamiya' acrylic paints. Thin the 'AK' paints with their acrylic thinners (AK712) and the 'Tamiya' with their X20A thinners.*

Over pants - Uniform Light AK3092 with Black Uniform Base AK3002 highlights, buttons 'Mr. Colour' Stainless Steel (213).

Boots - Uniform Base AK3091 over Uniform Light AK3092. Soles Brown Leather AK3031 with Black Uniform Base AK3002, Straps Brown Leather AK3031.

Balaclava - Uniform Base AK3091.

Coat - Black Uniform Base AK3002, Faded White AK3029, highlights 'Tamiya' Buff (XF57).

Life Jacket - 'Tamiya' Deck Tan (XF55).

Helmet - Brown Leather AK3031 with Black Uniform Base AK3002.

Gloves - Brown Leather AK3031, Faded White AK3029, highlights 'Tamiya' Buff (XF57).

Goggles - Brown Leather AK3031, 'Mr. Colour' Stainless Steel (213), 'Tamiya' Clear Yellow (X24).

Scarf - French Uniform Light AK3102.

Flesh - Light Flesh AK3012 with Highlight Flesh AK3013.

Assembly:

Using CA adhesive, secure the two arms onto the figure.

Finish:

Brush a semi-matte sealing coat, such as 'Tamiya' X35 thinned with their X20A, over the helmet and gloves, the coat and the boots.

Thin 'AK Interactive' Kerosene with enamel thinners and brush onto the figure to add grime. Paint areas such as the helmet and gloves, scarf and balaclava.



PART 15

DISPLAY BASE

PART 15 - DISPLAY BASE

The display case is made from piano black and clear acrylic sheet of 3mm thickness. The base shoulder, for locating the clear cover, is a second thickness on top of the base plate. This case was purpose built by Paul Moss, who has a retail outlet on Ebay - www.inperspective.com

For this display I chose to use the 'Abandoned Airfield' display mat (1:32 scale), supplied from 'Coastal Kits' - <http://www.coastalkits.co.uk/newstore>

The display mat consists of a photograph, taken from above and at a slight angle, then printed with odourless latex ink onto laminated matt vinyl over a 3mm thick 'Foamex' base board. These mats, when viewed from above, give a good representation of the chosen terrain, but when viewed from 'ground level' are obviously flat and featureless.

Mat - cutting:

Position the model on the mat and select the area required.

Using light pressure with a pencil, draw the outline of the desired shape for the mat, on the top surface. When drawing the outline, do not use excessive pressure or the mat will retain the pencil mark, which may not be easy to remove afterwards.

Using a sharp, sturdy blade, such as a 'Stanley Knife' or similar, carefully cut around the outline. Do not try to cut entirely through the mat in one pass. Instead, take several cuts to separate the outlined mat from the rest of the mat.

Clean the cut edge of the mat by sanding. Sand downwards from the photographed side of the mat, to prevent upwards sanding possibly lifting the photographed edge.

If desired, mask the top surfaces around the edge of the cut out mat and brush paint with a suitable acrylic coloured paint.

Aircraft and equipment - securing:

When displaying a model in a display case, it is always best not to permanently fix the model to the display base, especially if the model is moved frequently, such as when transported to other locations. Vibration or impact to a display case with a fixed model can transmit to the model, causing breakage and damage. Therefore it's best to free stand the model in the display case, which also allows the model to be separately protected, if necessary, during transit.

NOTE: *This model is resin and as such much heavier than a similar sized styrene model. Also it is displayed on the beaching trolley and three trestles, and as such is in contact with the moveable ground equipment at only five points. Any movement of the display case can cause the model and ground equipment to move and damage to the model can occur. To make the model more stable, I chose to permanently secure it to the beaching trolley and rear float trestle, leaving just the two main float trestles free.*

On a flat surface, position the aircraft onto the beaching trolley and rear float trestle.

Position the two main float trestles under and in contact with the main floats.

Arrange the position of the aircraft and ground equipment so it is in contact with the trolley and trestles.

Check the alignment and position of the aircraft on the ground equipment when viewed from above and from the sides.

Use 'UHU' White Tack or similar to temporarily hold the ground equipment in position on the flat surface.

Note or lightly mark the aircraft contact points on the beaching trolley and the rear float trestle.

Mix a small amount of a two part epoxy adhesive, such as 'Araldite' Rapid.

Remove the aircraft from the ground equipment.

Apply a small amount of the mixed epoxy adhesive to the contact points on the beaching trolley and rear float trestle.

Relocate the aircraft in the same position as before and onto the applied adhesive on the ground equipment.

Leave the assembly until the epoxy adhesive has fully set.

NOTE: *The added weight of the beaching trolley and rear float trestle make the aircraft even heavier than before. The model will require adequate support with minimal handling, so as to avoid breakage or damage.*

Remove the 'UHU' White Tack and check that the beaching trolley and rear float trestles are securely attached to the aircraft.

Information plaque:

A matching acrylic piano black plaque stand was positioned to the left, front corner of the display base (just in from the edges of the shoulder for locating the transparent acrylic cover.

The area on the underside of the stand and its contact area on the display base were scuffed using a coarse grit sand paper, in order to give a key for the adhesive.

A thin coat of contact adhesive was then applied to both scuffed areas and once the adhesive started to set, the stand was carefully position onto the display bae and pressed down to make full contact.

The self-adhesive backed information plaque was the positioned onto the stand and pressed to make full contact.

Display - assembly:

NOTE: *During this stage, make sure the model is positioned on the base of the display case such that it clears the display cover when placed onto the base.*

Place the mat onto a sheet of paper and trace its outline onto the paper.

Cut out and discard the shape of the mat from the paper.

Place the paper template onto the display base in the correct position for the mat.

Using a soft marker, trace the outline of the mat onto the display base.

Remove the paper template and scuff inside the mat outline using a coarse grit sand paper, in order to give a key for the adhesive.

Blow away any residual acrylic dust from the display base.

NOTE: *During the next step, do not apply too much adhesive, otherwise when pressure is applied over the mat, excess adhesive may be pressed out from the edges of the mat, spoiling the finish at the mat edges.*

Apply PVA adhesive to the underside of the mat and position it onto the scuffed area on the display base.

Apply pressure on the mat, such as books or similar, until the adhesive fully sets.

Place the model assembly in its final position on the mat.

Position the two main float trestle under and in contact with the main floats.

Position the pilot figure in the desired location on the mat and mark the location of the leg support rod onto the mat.

Drill a 0.8 mm diameter hole through the mat and into, but not through, the display base.

Snip the rod in the figure to the required length for inserting into the display.

Secure the figure into the pre-drilled hole in the display base, using CA adhesive or PVA (White Glue) applied to the support rod.



PART 16
COMPLETED
MODEL
PHOTOGRAPHS



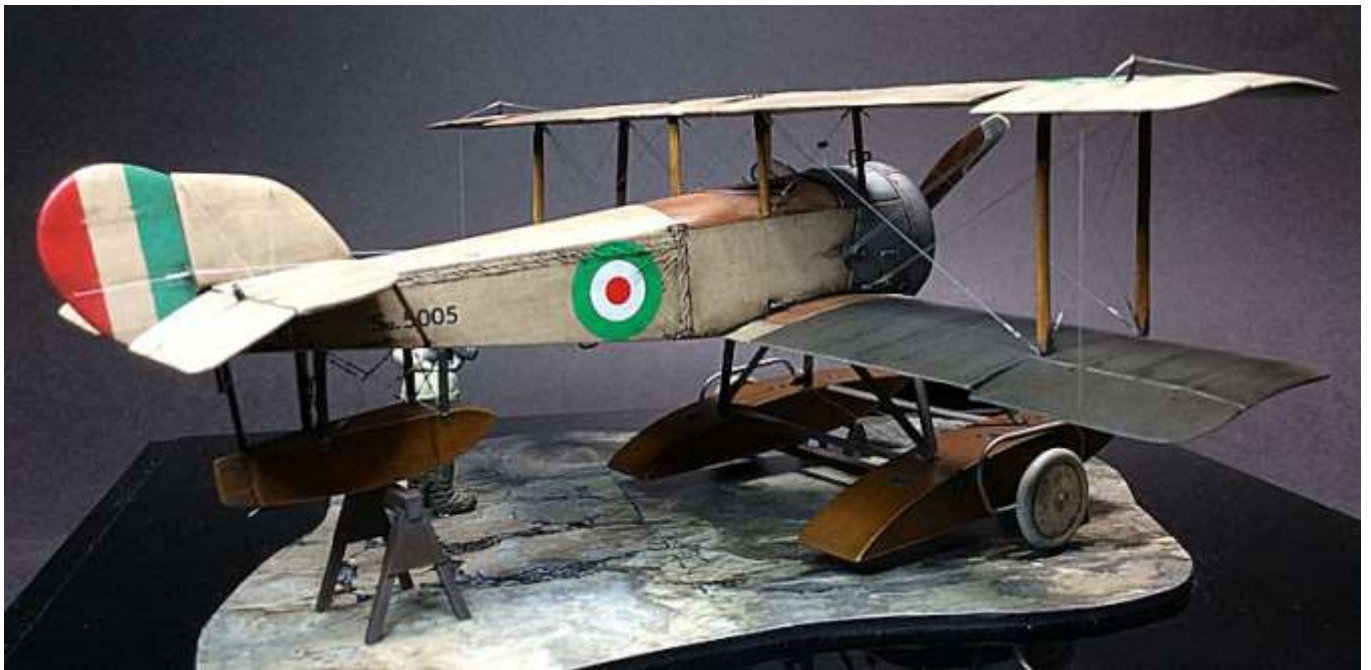

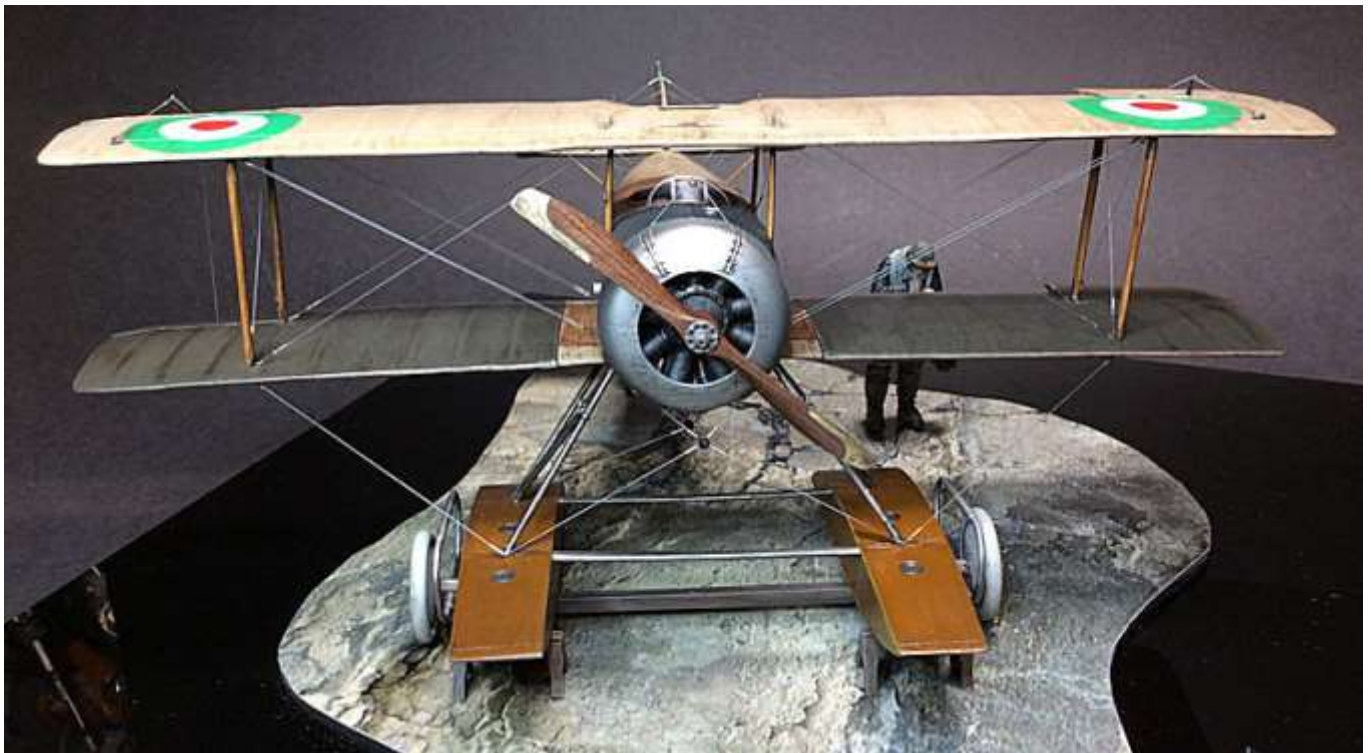

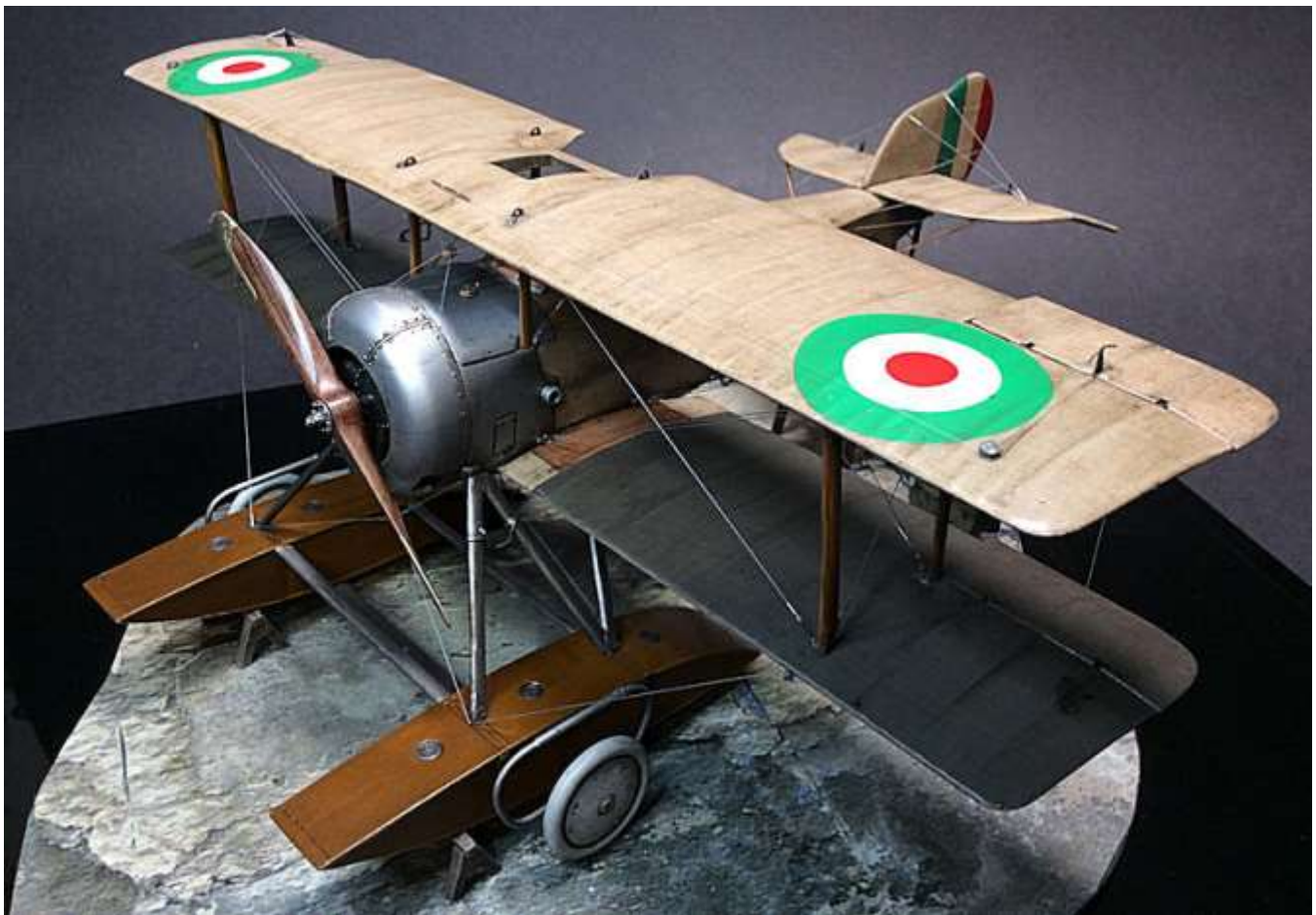
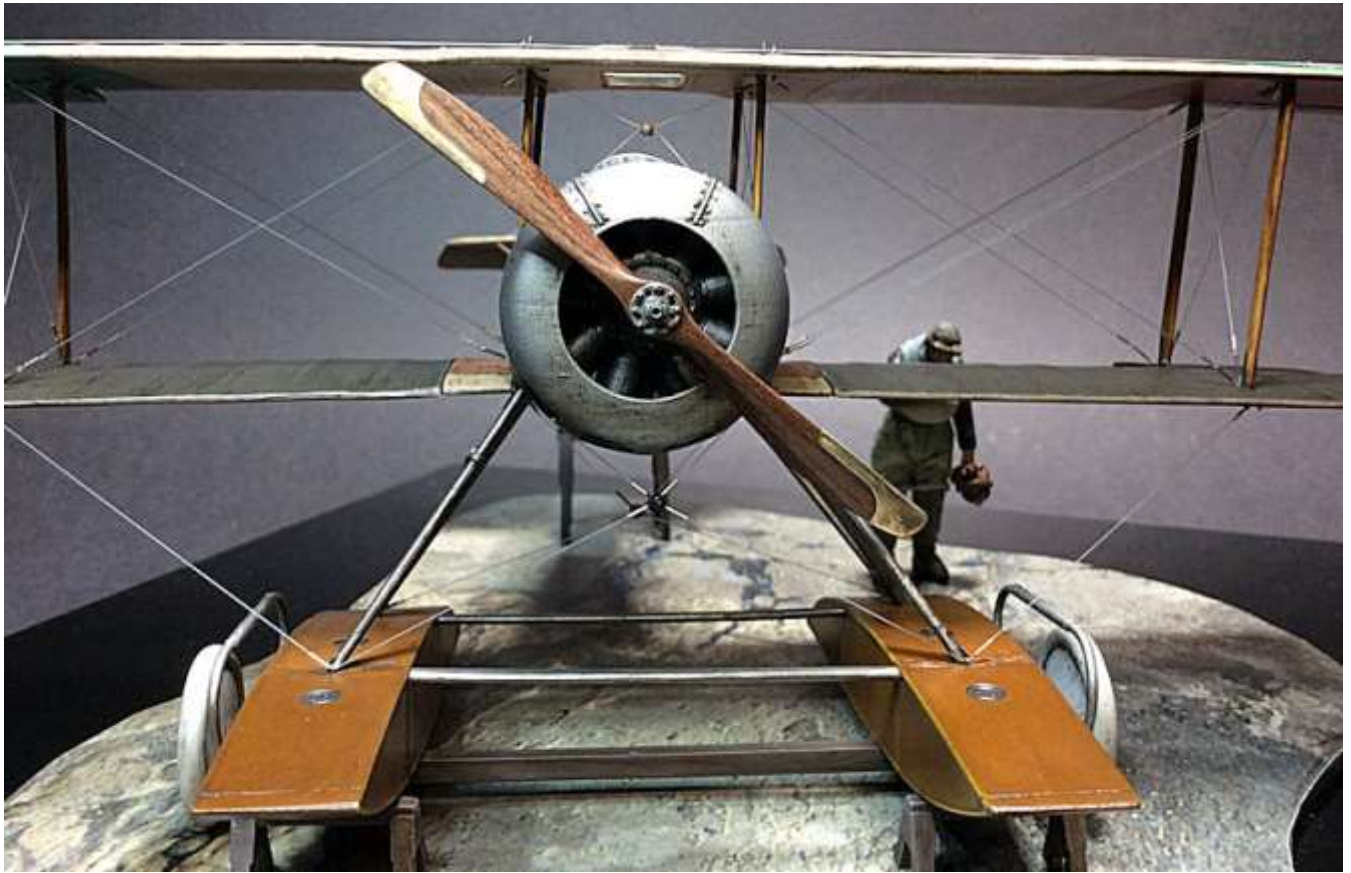



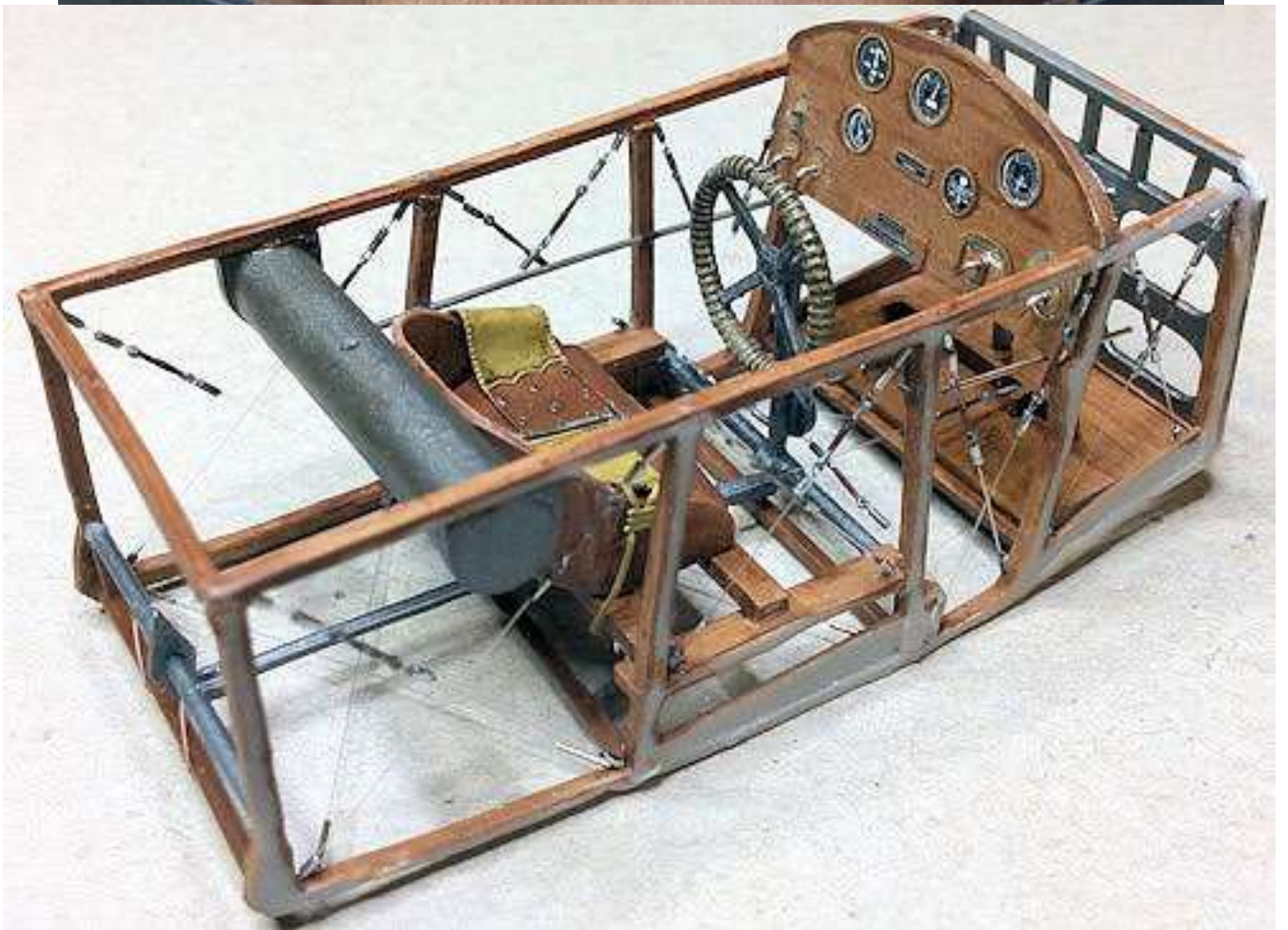
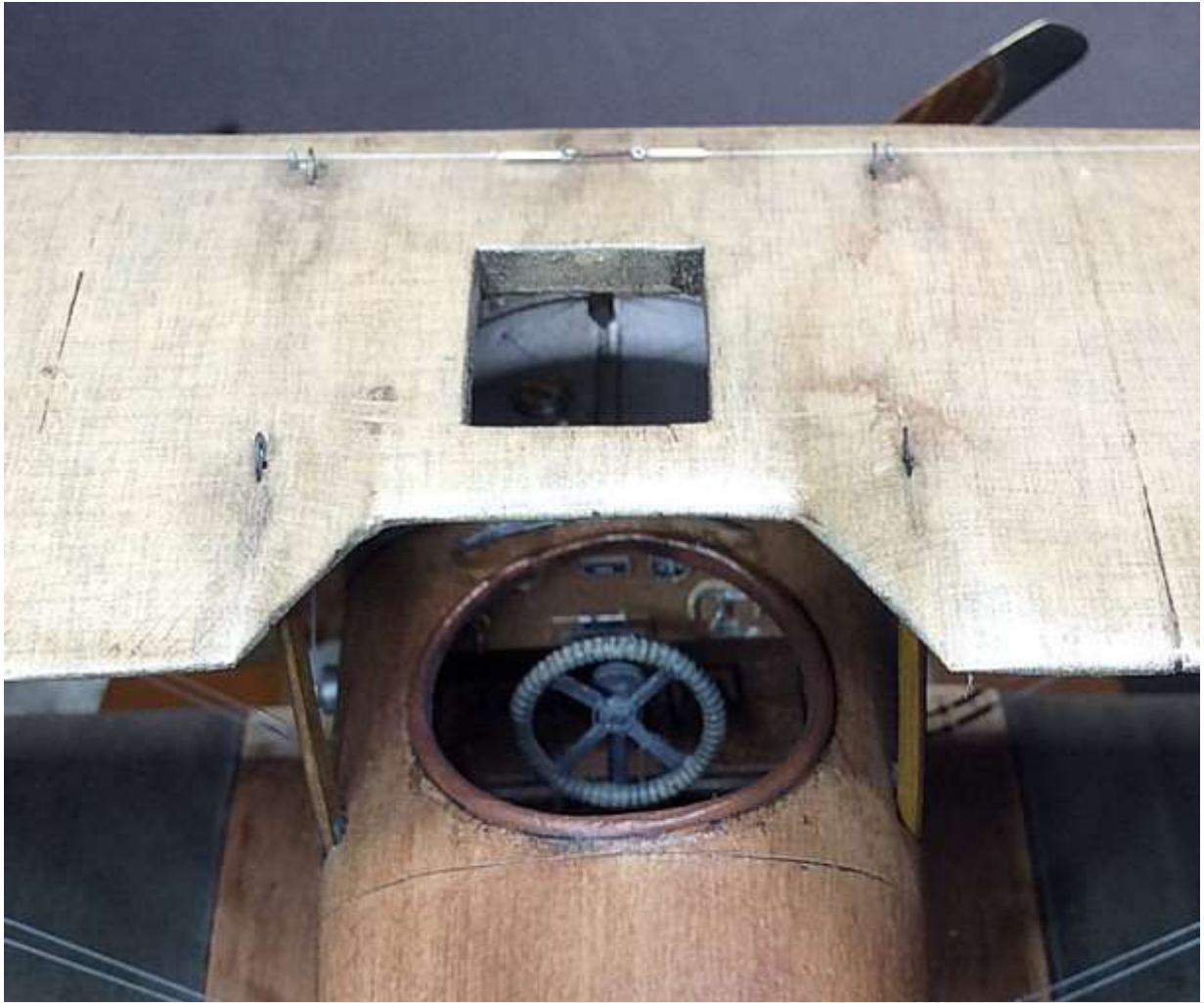



END